

SKM400GB12V



SEMITRANS® 3

SKM400GB12V

Target Data

Features

- $V_{CE(sat)}$ with positive temperature coefficient
- High short circuit capability, self limiting to 6 x I_{Cnom}
- Fast & soft inverse CAL diodes
- Large clearance (10 mm) and creepage distances (20 mm)
- Isolated copper baseplate using DBC Technology (Direct Copper Bonding)
- UL recognized, file no. E63532

Typical Applications*

- AC inverter drives
- UPS
- Electronic welders at fsw up to 20 kHz

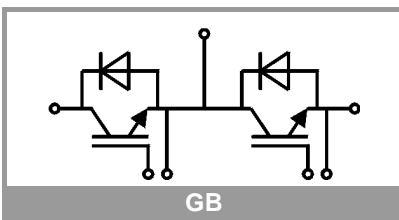

Absolute Maximum Ratings				
Symbol	Conditions		Values	Unit
IGBT				
V_{CES}			1200	V
I_C	$T_j = 175\text{ °C}$	$T_c = 25\text{ °C}$	598	A
		$T_c = 80\text{ °C}$	451	A
I_{Cnom}			400	A
I_{CRM}	$I_{CRM} = 3 \times I_{Cnom}$		1200	A
V_{GES}			-20 ... 20	V
t_{psc}	$V_{CC} = 720\text{ V}$ $V_{GE} \leq 20\text{ V}$ $V_{CES} \leq 1200\text{ V}$	$T_j = 125\text{ °C}$	10	μs
T_j			-40 ... 175	$^{\circ}\text{C}$
Inverse diode				
I_F	$T_j = 175\text{ °C}$	$T_c = 25\text{ °C}$	440	A
		$T_c = 80\text{ °C}$	329	A
I_{Fnom}			400	A
I_{FRM}	$I_{FRM} = 3 \times I_{Fnom}$		1200	A
I_{FSM}	$t_p = 10\text{ ms}$, sin 180°, $T_j = 25\text{ °C}$		1980	A
T_j			-40 ... 175	$^{\circ}\text{C}$
Module				
$I_{t(RMS)}$			500	A
T_{stg}			-40 ... 125	$^{\circ}\text{C}$
V_{isol}	AC sinus 50Hz, $t = 1\text{ min}$		4000	V

Characteristics						
Symbol	Conditions		min.	typ.	max.	Unit
IGBT						
$V_{CE(sat)}$	$I_C = 100\text{ A}$ $V_{GE} = 15\text{ V}$ chipllevel	$T_j = 25\text{ °C}$	1.75	2.2		V
		$T_j = 150\text{ °C}$	2.2	2.65		V
V_{CE0}			$T_j = 25\text{ °C}$	0.94	1.25	V
			$T_j = 150\text{ °C}$	0.88	1.22	V
r_{CE}	$V_{GE} = 15\text{ V}$	$T_j = 25\text{ °C}$	2.0	2.4		$\text{m}\Omega$
		$T_j = 150\text{ °C}$	3.3	3.6		$\text{m}\Omega$
$V_{GE(th)}$	$V_{GE} = V_{CE}$, $I_C = 16\text{ mA}$		6	6.5	7	V
I_{CES}	$V_{GE} = 0\text{ V}$ $V_{CE} = 1200\text{ V}$	$T_j = 25\text{ °C}$	0.1	0.3		mA
		$T_j = 150\text{ °C}$				mA
C_{res}	$V_{CE} = 25\text{ V}$ $V_{GE} = 0\text{ V}$		$f = 1\text{ MHz}$		24.04	nF
C_{oes}			$f = 1\text{ MHz}$		2.36	nF
C_{res}			$f = 1\text{ MHz}$		2.356	nF
Q_G					4600	nC
R_{Gint}					1.9	Ω
$t_{d(on)}$	$V_{CC} = 600\text{ V}$	$T_j = 150\text{ °C}$				ns
t_r	$I_C = 400\text{ A}$	$T_j = 150\text{ °C}$				ns
E_{on}	$V_{GE} = \pm 15\text{ V}$	$T_j = 150\text{ °C}$	36			mJ
$t_{d(off)}$	$R_{G on} = 0.5\ \Omega$	$T_j = 150\text{ °C}$				ns
t_f	$R_{G off} = 0.5\ \Omega$	$T_j = 150\text{ °C}$				ns
E_{off}			28			mJ
$R_{th(j-c)}$	per IGBT				0.072	K/W

SKM400GB12V



SEMITRANS® 3

SKM400GB12V

Target Data

Features

- $V_{CE(sat)}$ with positive temperature coefficient
- High short circuit capability, self limiting to $6 \times I_{cnom}$
- Fast & soft inverse CAL diodes
- Large clearance (10 mm) and creepage distances (20 mm)
- Isolated copper baseplate using DBC Technology (Direct Copper Bonding)
- UL recognized, file no. E63532

Typical Applications*

- AC inverter drives
- UPS
- Electronic welders at fsw up to 20 kHz

Characteristics						
Symbol	Conditions		min.	typ.	max.	Unit
Inverse diode						
$V_F = V_{EC}$	$I_F = 400 \text{ A}$ $V_{GE} = 0 \text{ V}$ chip	$T_j = 25 \text{ }^\circ\text{C}$		2.2	2.5	V
		$T_j = 150 \text{ }^\circ\text{C}$		2.1	2.5	V
V_{F0}		$T_j = 25 \text{ }^\circ\text{C}$		1.3	1.5	V
		$T_j = 150 \text{ }^\circ\text{C}$		0.9	1.1	V
r_F		$T_j = 25 \text{ }^\circ\text{C}$		2.3	2.5	m Ω
		$T_j = 150 \text{ }^\circ\text{C}$		3.1	3.4	m Ω
I_{RRM}	$I_F = 400 \text{ A}$	$T_j = 150 \text{ }^\circ\text{C}$		450		A
Q_{rr}	$di/dt_{off} = 8800 \text{ A}/\mu\text{s}$	$T_j = 150 \text{ }^\circ\text{C}$		68		μC
E_{rr}	$V_{GE} = \pm 15 \text{ V}$ $V_{CC} = 600 \text{ V}$	$T_j = 150 \text{ }^\circ\text{C}$		30.5		mJ
$R_{th(j-c)}$	per diode				0.14	K/W
Module						
L_{CE}				15	20	nH
$R_{CC+EE'}$	terminal-chip	$T_C = 25 \text{ }^\circ\text{C}$		0.25		m Ω
		$T_C = 125 \text{ }^\circ\text{C}$		0.5		m Ω
$R_{th(c-s)}$	per module			0.02	0.038	K/W
M_s	to heat sink M6		3		5	Nm
M_t	to terminals M6		2.5		5	Nm
						Nm
w					325	g

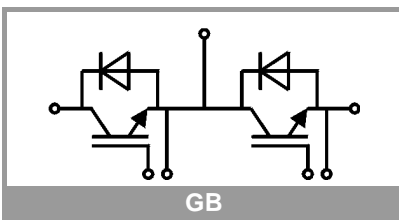

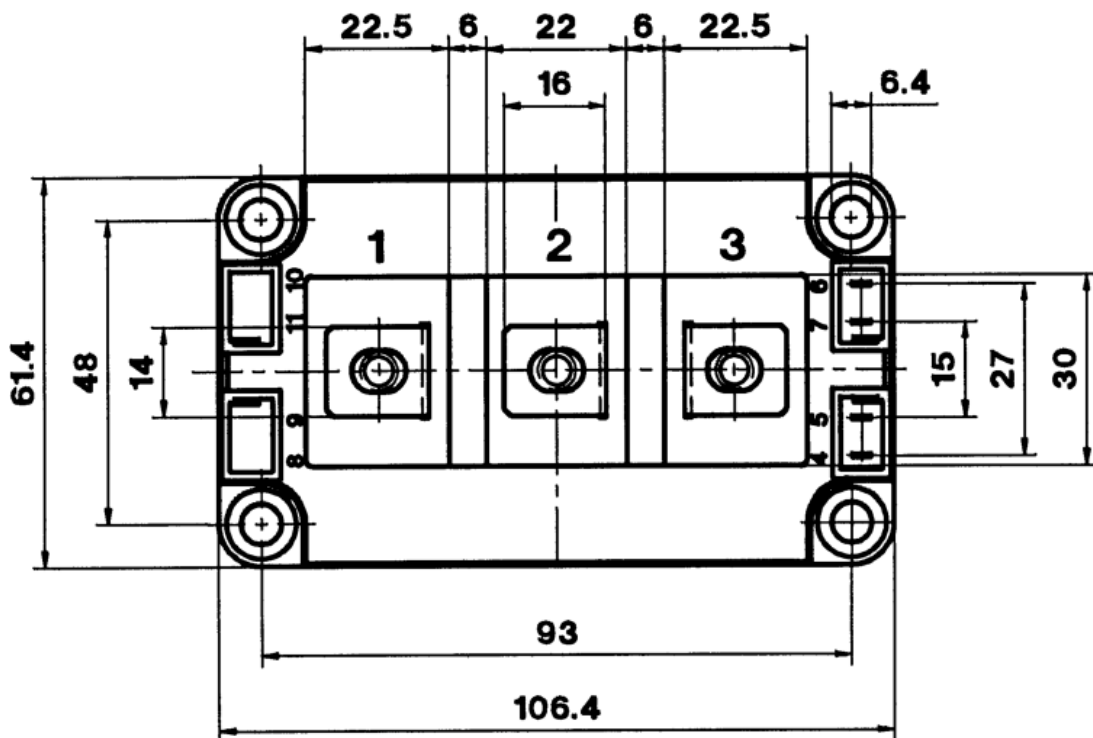
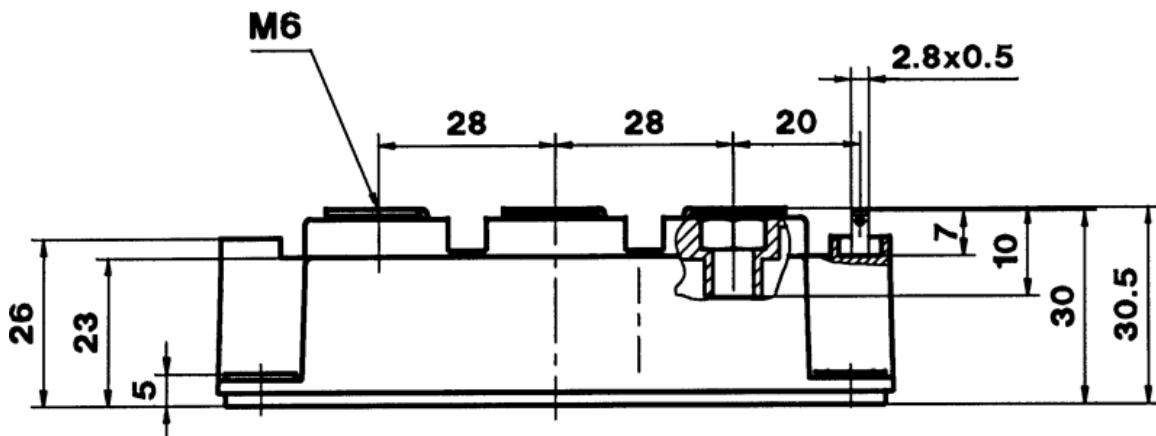

SEMITRANS 3

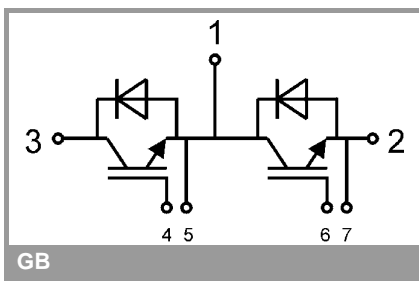

GB

This is an electrostatic discharge sensitive device (ESDS), international standard IEC 60747-1, Chapter IX

* The specifications of our components may not be considered as an assurance of component characteristics. Components have to be tested for the respective application. Adjustments may be necessary. The use of SEMIKRON products in life support appliances and systems is subject to prior specification and written approval by SEMIKRON. We therefore strongly recommend prior consultation of our personal.