

TRIPLE DIFFUSED PLANER TYPE
ULTRA HIGH β TRANSISTOR
HIGH VOLTAGE POWER AMPLIFIER

■ **Features**

- High D.C. current gain
- Low saturation voltage
- High reliability

■ **Applications**

- Audio power amplifiers
- Relay & solenoid drivers
- Motor controls
- General purpose power amplifiers
- Including zener diode

■ **Maximum ratings and characteristics**

- Absolute maximum ratings ($T_c=25^\circ\text{C}$ unless otherwise specified)

Item	Symbol	Ratings	Unit
Collector-Base voltage	V_{CB0}	(450)	V
Collector-Emitter voltage	V_{CE0}	(450)	V
Collector-Emitter voltage	$V_{CE0(SUS)}$	300	V
Emitter-Base voltage	V_{EBO}	6	V
Zener voltage	V_Z	300	V
Collector current	I_C	6	A
Base current	I_B	2.5	A
Collector power dissipation	P_C	40	W
Operating junction temperature	T_j	+150	$^\circ\text{C}$
Storage temperature	T_{stg}	-40 to +150	$^\circ\text{C}$

- Electrical characteristics ($T_c = 25^\circ\text{C}$ unless otherwise specified)

Item	Symbol	Test Conditions	Min.	Typ.	Max.	Units
Collector-Base voltage	V_{CB0}	$I_{CBO} = 0.1\text{mA}$	(450)			V
Collector-Emitter voltage	V_{CE0}	$I_{CEO} = 1\text{mA}$	(450)			V
Collector-Emitter voltage	$V_{CE0(SUS)}$	$I_C = 8\text{A}$	300			V
Emitter-Base voltage	V_{EBO}	$I_{EBO} = 150\text{mA}$	6			V
Zener voltage	V_Z	$I_Z = 0.1\text{mA}$	300		450	V
Collector-Base leakage current	I_{CBO}	$V_{CB0} = 300\text{V}$			0.1	mA
Emitter-Base leakage current	I_{EBO}	$V_{EBO} = 6\text{V}$			150	mA
D.C. current gain	h_{FE}	$I_C = 4\text{A}, V_{CE} = 2\text{V}$	500			
Collector-Emitter saturation voltage	$V_{CE(Sat)}$	$I_C = 4\text{A}, I_B = 15\text{mA}$			1.5	V
Base-Emitter saturation voltage	$V_{BE(Sat)}$				2.0	V

- Thermal characteristics

Item	Symbol	Test Conditions	Min.	Typ.	Max.	Units
Thermal resistance	$R_{th(j-c)}$	Junction to case			3.0	$^\circ\text{C/W}$

■ **Outline Drawings**

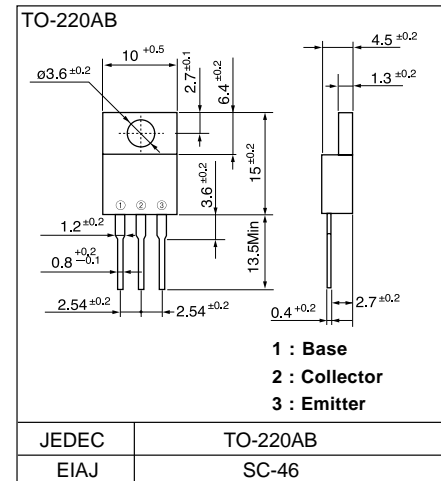

■ **Equivalent Circuit Schematic**

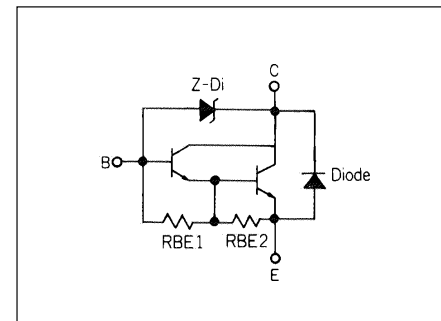

Characteristics

