

# SKM150GB12VG



SEMITRANS® 3

## SKM150GB12VG

### Target Data

### Features

- $V_{CE(sat)}$  with positive temperature coefficient
- High short circuit capability, self limiting to 6 x  $I_{Cnom}$
- Fast & soft inverse CAL diodes
- Large clearance (10 mm) and creepage distances (20 mm)
- Isolated copper baseplate using DBC Technology (Direct Copper Bonding)
- UL recognized, file no. E63532

### Typical Applications\*

- AC inverter drives
- UPS
- Electronic welders at fsw up to 20 kHz

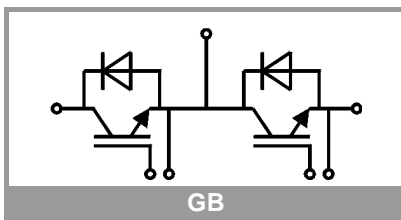

Absolute Maximum Ratings				
Symbol	Conditions		Values	Unit
<b>IGBT</b>				
$V_{CES}$			1200	V
$I_C$	$T_j = 175\text{ °C}$	$T_c = 25\text{ °C}$	235	A
		$T_c = 80\text{ °C}$	176	A
$I_{Cnom}$			150	A
$I_{CRM}$	$I_{CRM} = 3 \times I_{Cnom}$		450	A
$V_{GES}$			-20 ... 20	V
$t_{psc}$	$V_{CC} = 720\text{ V}$ $V_{GE} \leq 20\text{ V}$ $V_{CES} \leq 1200\text{ V}$	$T_j = 125\text{ °C}$	10	$\mu\text{s}$
$T_j$			-40 ... 175	$^{\circ}\text{C}$
<b>Inverse diode</b>				
$I_F$	$T_j = 175\text{ °C}$	$T_c = 25\text{ °C}$	187	A
		$T_c = 80\text{ °C}$	140	A
$I_{Fnom}$			150	A
$I_{FRM}$	$I_{FRM} = 3 \times I_{Fnom}$		450	A
$I_{FSM}$	$t_p = 10\text{ ms}$ , $\sin 180^{\circ}$ , $T_j = 25\text{ °C}$		774	A
$T_j$			-40 ... 175	$^{\circ}\text{C}$
<b>Module</b>				
$I_{t(RMS)}$			500	A
$T_{stg}$			-40 ... 125	$^{\circ}\text{C}$
$V_{isol}$	AC sinus 50Hz, $t = 1\text{ min}$		4000	V

Characteristics						
Symbol	Conditions		min.	typ.	max.	Unit
<b>IGBT</b>						
$V_{CE(sat)}$	$I_C = 75\text{ A}$ $V_{GE} = 15\text{ V}$ chipllevel	$T_j = 25\text{ °C}$	1.85	2.3		V
		$T_j = 150\text{ °C}$	2.25	2.45		V
$V_{CE0}$			0.94	1.25		V
			0.88	1.22		V
$r_{CE}$	$V_{GE} = 15\text{ V}$	$T_j = 25\text{ °C}$	6.1	7.0		$\text{m}\Omega$
		$T_j = 150\text{ °C}$	9.1	8.2		$\text{m}\Omega$
$V_{GE(th)}$	$V_{GE} = V_{CE}$ , $I_C = 6\text{ mA}$		6	6.5	7	V
$I_{CES}$	$V_{GE} = 0\text{ V}$ $V_{CE} = 1200\text{ V}$	$T_j = 25\text{ °C}$	0.1	0.3		mA
		$T_j = 150\text{ °C}$				mA
$C_{res}$				9		nF
$C_{oes}$	$V_{CE} = 25\text{ V}$ $V_{GE} = 0\text{ V}$			0.89		nF
$C_{res}$				0.884		nF
$Q_G$				1600		nC
$R_{Gint}$				5.0		$\Omega$
$t_{d(on)}$	$V_{CC} = 600\text{ V}$	$T_j = 150\text{ °C}$				ns
$t_r$	$I_C = 150\text{ A}$	$T_j = 150\text{ °C}$				ns
$E_{on}$	$V_{GE} = \pm 15\text{ V}$ $R_{G on} = 0.67\text{ }\Omega$	$T_j = 150\text{ °C}$		14		mJ
$t_{d(off)}$	$R_{G off} = 0.67\text{ }\Omega$	$T_j = 150\text{ °C}$				ns
$t_f$						ns
$E_{off}$				11		mJ
$R_{th(j-c)}$	per IGBT				0.2	K/W

# SKM150GB12VG



SEMITRANS® 3

## SKM150GB12VG

### Target Data

### Features

- $V_{CE(sat)}$  with positive temperature coefficient
- High short circuit capability, self limiting to  $6 \times I_{cnom}$
- Fast & soft inverse CAL diodes
- Large clearance (10 mm) and creepage distances (20 mm)
- Isolated copper baseplate using DBC Technology (Direct Copper Bonding)
- UL recognized, file no. E63532

### Typical Applications\*

- AC inverter drives
- UPS
- Electronic welders at fsw up to 20 kHz

Characteristics						
Symbol	Conditions		min.	typ.	max.	Unit
<b>Inverse diode</b>						
$V_F = V_{EC}$	$I_F = 150 \text{ A}$ $V_{GE} = 0 \text{ V}$ chip	$T_j = 25 \text{ }^\circ\text{C}$		2.2	2.5	V
		$T_j = 150 \text{ }^\circ\text{C}$		2.1	2.4	V
$V_{F0}$		$T_j = 25 \text{ }^\circ\text{C}$		1.3	1.5	V
		$T_j = 150 \text{ }^\circ\text{C}$		0.9	1.1	V
$r_F$		$T_j = 25 \text{ }^\circ\text{C}$		5.8	6.6	m $\Omega$
		$T_j = 150 \text{ }^\circ\text{C}$		8.1	8.8	m $\Omega$
$I_{RRM}$	$I_F = 150 \text{ A}$ $di/dt_{off} = 3100 \text{ A}/\mu\text{s}$ $V_{GE} = \pm 15 \text{ V}$ $V_{CC} = 600 \text{ V}$	$T_j = 150 \text{ }^\circ\text{C}$		120		A
$Q_{rr}$		$T_j = 150 \text{ }^\circ\text{C}$		31.3		$\mu\text{C}$
$E_{rr}$		$T_j = 150 \text{ }^\circ\text{C}$			13	
$R_{th(j-c)}$	per diode				0.31	K/W
<b>Module</b>						
$L_{CE}$				15	20	nH
$R_{CC+EE'}$	terminal-chip	$T_C = 25 \text{ }^\circ\text{C}$		0.25		m $\Omega$
		$T_C = 125 \text{ }^\circ\text{C}$		0.5		m $\Omega$
$R_{th(c-s)}$	per module			0.02	0.038	K/W
$M_s$	to heat sink M6		3		5	Nm
$M_t$	to terminals M6		2.5		5	Nm
						Nm
w					325	g

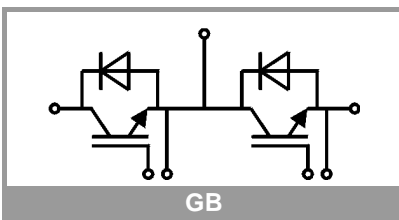

GB

# SKM150GB12VG

CASED56

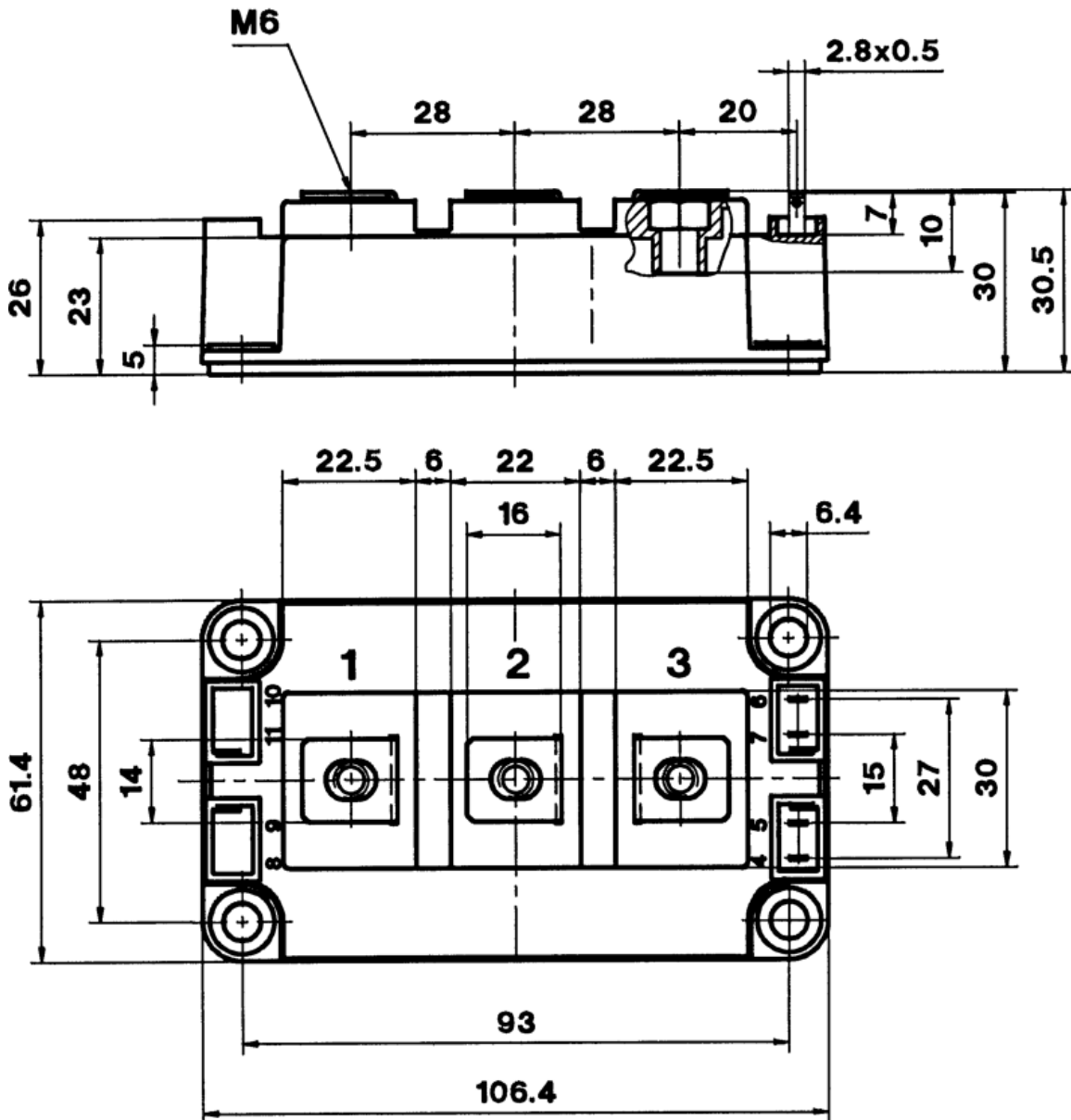

SEMITRANS 3

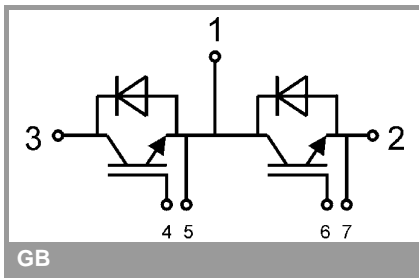

This is an electrostatic discharge sensitive device (ESDS), international standard IEC 60747-1, Chapter IX

\* The specifications of our components may not be considered as an assurance of component characteristics. Components have to be tested for the respective application. Adjustments may be necessary. The use of SEMIKRON products in life support appliances and systems is subject to prior specification and written approval by SEMIKRON. We therefore strongly recommend prior consultation of our personal.