

# 2FI100A(2x100A)

## FAST RECOVERY DIODE MODULE

**300V,600V / 100A**  
**2 in one-package**

**FAST RECOVERY DIODE MODULE**

### ■ Features

- Short Reverse Recovery Time
- Variety of Connection Menu
- Insulated Type

### ■ Applications

- Arc-Welders
- Free-Wheeling Diode
- High Speed Rectifiers

### ■ Outline Drawings, mm

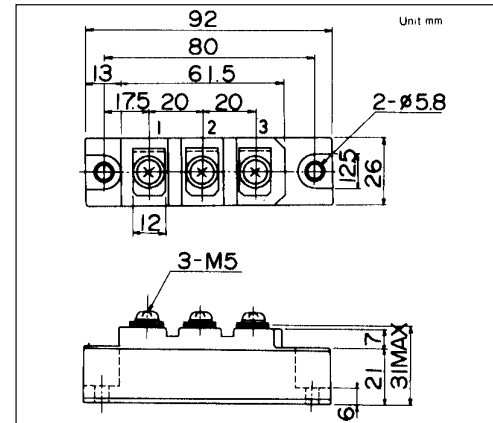

### ■ Inner Circuit Schematic

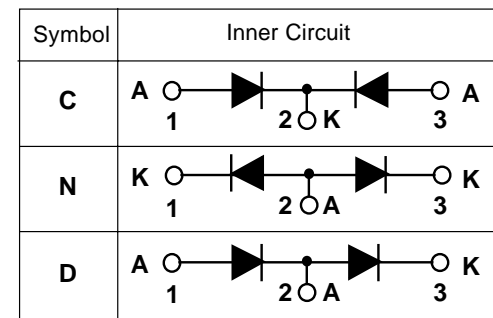

### ■ Maximum ratings and characteristics

#### ● Absolute maximum ratings

Item	Symbol	Conditions	Rating		Unit
			-030	-060	
Repetitive peak reverse voltage	$V_{RRM}$		300	600	V
Non-repetitive peak reverse voltage	$V_{RSM}$		350	650	V
Average output current	$I_{F(AV)}$	50/60Hz Square wave, $T_c=86^\circ\text{C}$	2 x 100		A
Surge current	$I_{FSM}$	From rated load, Sine wave 10ms	1600		A
$I^2t$	$I^2t$	From rated load	10240		$\text{A}^2\text{s}$
Operating junction temperature	$T_j$		-40 to +150		$^\circ\text{C}$
Storage temperature	$T_{stg}$		-40 to +150		$^\circ\text{C}$
Isolation voltage	$V_{is}$		AC1500(1min.)		V
Screw torque		(M5)	3.5 *1		N·m

\*1: Recommendable value : 2.5 to 3.0 N·m(M5)

#### ● Electrical characteristics ( $T_a=25^\circ\text{C}$ Unless otherwise specified)

Item	Symbol	Conditions	Min.	Typ.	Max.	Unit
Forward voltage drop	$V_{FM}$	$T_j=25^\circ\text{C}$ , $I_{FM}=100\text{A}$			1.25	V
Reverse current	$I_{RRM}$	$T_j=150^\circ\text{C}$ , $V_R=V_{RRM}$			60	mA
Reverse recovery time	$t_{rr}$	$T_j=25^\circ\text{C}$ , $I_F=I_R=0.1\text{A}$			0.5	$\mu\text{s}$

#### ● Thermal Characteristics

Item	Symbol	Conditions	Min.	Typ.	Max.	Unit
Thermal resistance	$R_{th(j-c)}$	Junction to case			0.20	$^\circ\text{C/W}$
	$R_{th(c-f)}$	the base to cooling fin *			0.10	$^\circ\text{C/W}$

\* : With Thermal Compound

■ Characteristics

Forward Characteristics

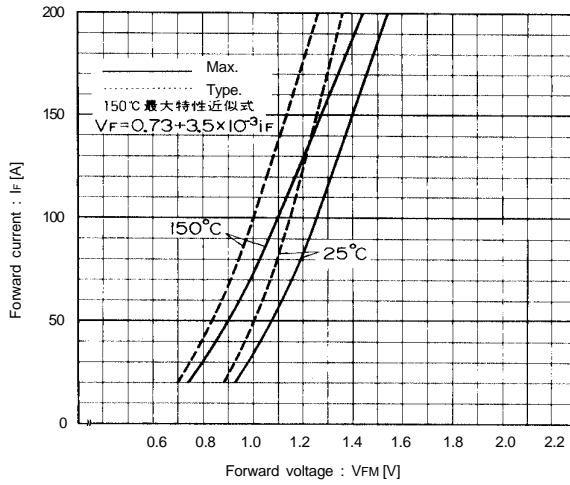

Output Current - Total Loss - Ambient Temperature

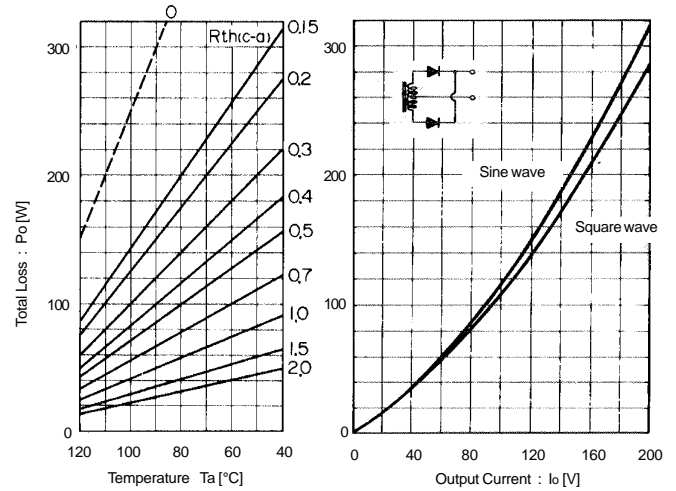

Reverse Recovery Characteristics

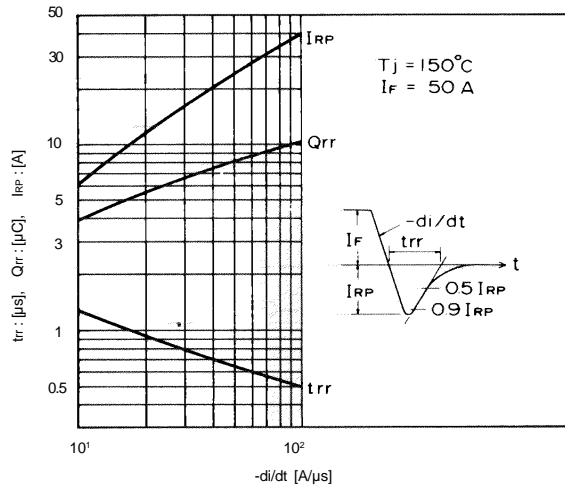

Surge Current

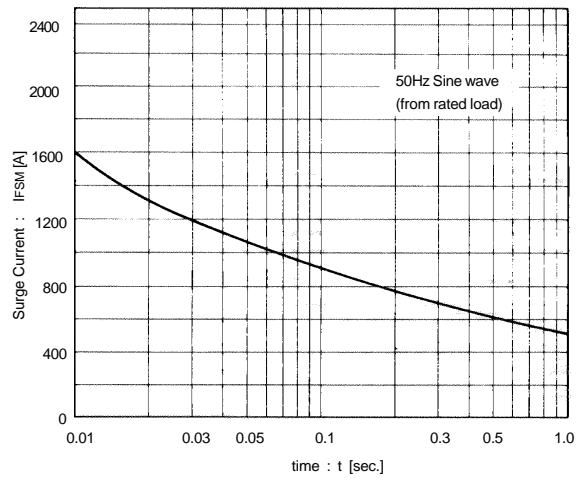

Transient Thermal Impedance

