

PM15RSH120

FLAT-BASE TYPE
INSULATED PACKAGE

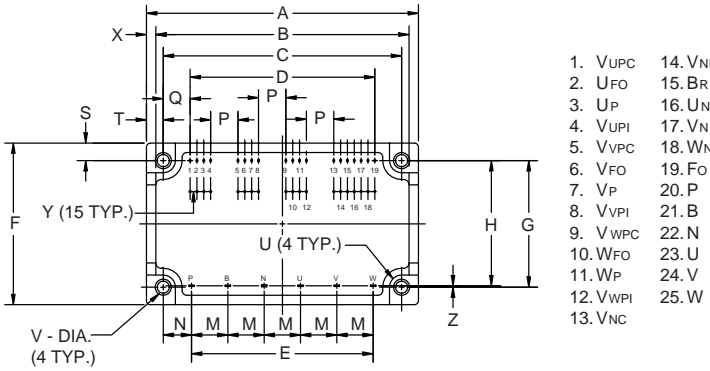

1. V_{UPC}
2. U_{FO}
3. U_P
4. V_{UPI}
5. V_{VPC}
6. V_{FO}
7. V_P
8. V_{VPI}
9. V_{WPC}
10. W_{FO}
11. W_P
12. V_{WPI}
13. V_{NC}
14. V_{NI}
15. B_R
16. U_N
17. V_N
18. W_N
19. F_O
20. P
21. B
22. N
23. U
24. V
25. W

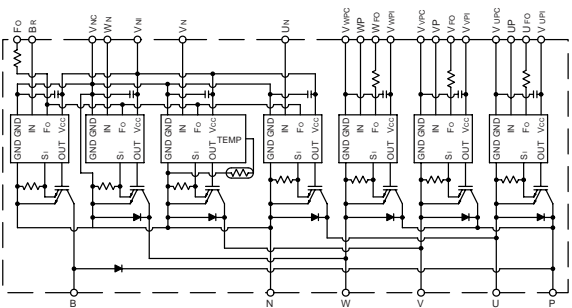
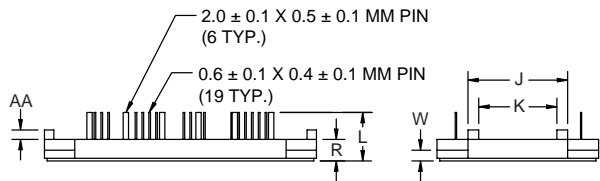

Outline Drawing and Circuit Diagram

Dimensions	Inches	Millimeters
A	3.98±0.04	101.0±1.0
B	3.78	96.0
C	3.48±0.03	88.5±0.8
D	2.700±0.03	68.58±0.8
E	2.66±0.02	67.5±0.5
F	2.36±0.04	60.0±1.0
G	1.85±0.02	47.0±0.5
H	1.83±0.03	46.5±0.8
J	1.28	32.6
K	0.97	24.6
L	0.71±0.04	18.0±1.0
M	0.53±0.01	13.5±0.3

Dimensions	Inches	Millimeters
N	0.41	10.5
P	0.400	10.16
Q	0.392	9.96
R	0.31	8.0
S	0.26	6.5
T	0.246	6.25
U	0.18 Rad.	Rad. 4.5
V	0.18 Dia.	Dia. 4.5
W	0.17±0.02	4.4±0.5
X	0.10	2.5
Y	0.100±0.01	2.54±0.25
Z	0.02	0.5
AA	0.14	3.5



Description:
Mitsubishi Intelligent Power Modules are isolated base modules designed for power switching applications operating at frequencies to 20kHz. Built-in control circuits provide optimum gate drive and protection for the IGBT and free-wheel diode power devices.

- Features:**
- Complete Output Power Circuit
 - Gate Drive Circuit
 - Protection Logic
 - Short Circuit
 - Over Current
 - Over Temperature
 - Under Voltage

- Applications:**
- Inverters
 - UPS
 - Motion/Servo Control
 - Power Supplies

Ordering Information:
Example: Select the complete part number from the table below -i.e. PM15RSH120 is a 1200V, 15 Ampere Intelligent Power Module.

Type	Current Rating Amperes	V _{CES} Volts (x 10)
PM	15	120



PM15RSH120**FLAT-BASE TYPE
INSULATED PACKAGE****Absolute Maximum Ratings, $T_j = 25^\circ\text{C}$ unless otherwise specified**

Ratings	Symbol	PM15RSH120	Units
Power Device Junction Temperature	T_j	-20 to 150	$^\circ\text{C}$
Storage Temperature	T_{stg}	-40 to 125	$^\circ\text{C}$
Case Operating Temperature	T_C	-20 to 100	$^\circ\text{C}$
Mounting Torque, M4 Mounting Screws	—	0.98 ~ 1.47	N · m
Module Weight (Typical)	—	100	Grams
Supply Voltage Protected by OC and SC ($V_D = 13.5 - 16.5\text{V}$, Inverter Part, $T_j = 125^\circ\text{C}$)	$V_{\text{CC(prot.)}}$	800	Volts
Isolation Voltage (Main Terminal to Baseplate, AC 1 min.)	V_{iso}	2500	Vrms

Control Sector

Supply Voltage (Applied between $V_{\text{UP1}}-V_{\text{UPC}}$, $V_{\text{VP1}}-V_{\text{VPC}}$, $V_{\text{WP1}}-V_{\text{WPC}}$, $V_{\text{N1}}-V_{\text{NC}}$)	V_D	20	Volts
Input Voltage (Applied between U_P-V_{UPC} , V_P-V_{VPC} , W_P-V_{WPC} , $U_N \cdot V_N \cdot W_N \cdot B_r-V_{\text{NC}}$)	V_{CIN}	20	Volts
Fault Output Supply Voltage Applied between ($U_{\text{FO}}-V_{\text{UPC}}$, $V_{\text{FO}}-V_{\text{VPC}}$, $W_{\text{FO}}-V_{\text{WPC}}$, F_O-V_{NC})	V_{FO}	20	Volts
Fault Output Current (Sink Current at U_{FO} , V_{FO} , W_{FO} and F_O Terminal)	I_{FO}	20	mA

IGBT Inverter Sector

Collector-Emitter Voltage ($V_D = 15\text{V}$, $V_{\text{CIN}} = 15\text{V}$)	V_{CES}	1200	Volts
Collector Current, ($T_C = 25^\circ\text{C}$)	I_C	15	Amperes
Peak Collector Current, ($T_C = 25^\circ\text{C}$)	I_{CP}	30	Amperes
Supply Voltage (Applied between P - N)	V_{CC}	900	Volts
Supply Voltage, Surge (Applied between P - N)	$V_{\text{CC(surge)}}$	1000	Volts
Collector Dissipation	P_C	83	Watts

Brake Sector

Collector-Emitter Voltage	V_{CES}	1200	Volts
Collector Current, ($T_C = 25^\circ\text{C}$)	I_C	10	Amperes
Peak Collector Current, ($T_C = 25^\circ\text{C}$)	I_{CP}	20	Amperes
Supply Voltage (Applied between P - N)	V_{CC}	900	Volts
Supply Voltage, Surge (Applied between P - N)	$V_{\text{CC(surge)}}$	1000	Volts
Collector Dissipation	P_C	41	Watts
Diode Forward Current	I_F	10	Amperes
Diode DC Reverse Voltage	$V_{\text{R(DC)}}$	1200	Volts

PM15RSH120

**FLAT-BASE TYPE
INSULATED PACKAGE**

Electrical and Mechanical Characteristics, $T_j = 25^\circ\text{C}$ unless otherwise specified

Characteristics	Symbol	Test Conditions	Min.	Typ.	Max.	Units
Control Sector						
Over Current Trip Level Inverter Part	OC	$-20^\circ\text{C} \leq T \leq 125^\circ\text{C}$, $V_D = 15\text{V}$	22	37	—	Amperes
Over Current Trip Level Brake Part			15	27	—	Amperes
Short Circuit Trip Level Inverter Part	SC	$-20^\circ\text{C} \leq T \leq 125^\circ\text{C}$, $V_D = 15\text{V}$	—	56	—	Amperes
Short Circuit Trip Level Brake Part			—	41	—	Amperes
Over Current Delay Time	$t_{\text{off(OC)}}$	$V_D = 15\text{V}$	—	10	—	μs
Over Temperature Protection	OT	Trip Level	100	110	120	$^\circ\text{C}$
	OT_r	Reset Level	—	90	—	$^\circ\text{C}$
Supply Circuit Under Voltage Protection	UV	Trip Level	11.5	12.0	12.5	Volts
	UV_r	Reset Level	—	12.5	—	Volts
Supply Voltage	V_D	Applied between $V_{\text{UP1}}-V_{\text{UPC}}$, $V_{\text{VP1}}-V_{\text{VPC}}$, $V_{\text{WP1}}-V_{\text{WPC}}$, $V_{\text{N1}}-V_{\text{NC}}$	13.5	15	16.5	Volts
Circuit Current	I_D	$V_D = 15\text{V}$, $V_{\text{CIN}} = 15\text{V}$, $V_{\text{N1}}-V_{\text{NC}}$	—	25	35	mA
		$V_D = 15\text{V}$, $V_{\text{CIN}} = 15\text{V}$, $V_{\text{XP1}}-V_{\text{XPC}}$	—	7	10	mA
Input ON Threshold Voltage	$V_{\text{th(on)}}$	Applied between	1.2	1.5	1.8	Volts
Input OFF Threshold Voltage	$V_{\text{th(off)}}$	U_P-V_{UPC} , V_P-V_{VPC} , W_P-V_{WPC} , $U_N \cdot V_N \cdot W_N \cdot B_r-V_{\text{NC}}$	1.7	2.0	2.3	Volts
PWM Input Frequency	f_{PWM}	3- ϕ Sinusoidal	—	15	20	kHz
Fault Output Current	$I_{\text{FO(H)}}$	$V_D = 15\text{V}$, $V_{\text{FO}} = 15\text{V}$	—	—	0.01	mA
	$I_{\text{FO(L)}}$	$V_D = 15\text{V}$, $V_{\text{FO}} = 15\text{V}$	—	10	15	mA
Minimum Fault Output Pulse Width	t_{FO}	$V_D = 15\text{V}$	1.0	1.8	—	ms

PM15RSH120FLAT-BASE TYPE
INSULATED PACKAGE**Electrical and Mechanical Characteristics, $T_j = 25^\circ\text{C}$ unless otherwise specified**

Characteristics	Symbol	Test Conditions	Min.	Typ.	Max.	Units
IGBT Inverter Sector						
Collector Cutoff Current	I_{CES}	$V_{CE} = V_{CES}, T_j = 25^\circ\text{C}$	—	—	1.0	mA
		$V_{CE} = V_{CES}, T_j = 125^\circ\text{C}$	—	—	10	mA
Emitter-Collector Voltage	V_{EC}	$-I_C = 15\text{A}, V_D = 15\text{V}, V_{CIN} = 5\text{V}$	—	2.5	3.5	Volts
Collector-Emitter Saturation Voltage	$V_{CE(sat)}$	$V_D = 15\text{V}, V_{CIN} = 0\text{V}, I_C = 15\text{A}$	—	2.3	3.3	Volts
		$V_D = 15\text{V}, V_{CIN} = 0\text{V}, I_C = 15\text{A}, T_j = 125^\circ\text{C}$	—	2.1	3.1	Volts
Inductive Load Switching Times	t_{on}		0.4	0.7	1.5	μs
	t_{rr}	$V_D = 15\text{V}, V_{CIN} = 0 \leftrightarrow 15\text{V}$	—	0.15	0.3	μs
	$t_{C(on)}$	$V_{CC} = 600\text{V}, I_C = 15\text{A}$	—	0.3	1.0	μs
	t_{off}	$T_j = 125^\circ\text{C}$	—	1.7	2.9	μs
	$t_{C(off)}$		—	0.7	1.3	μs
Brake Sector						
Collector-Emitter Saturation Voltage	$V_{CE(sat)}$	$V_D = 15\text{V}, V_{CIN} = 0\text{V}, I_C = 10\text{A}, T_j = 25^\circ\text{C}$	—	2.8	3.8	Volts
		$V_D = 15\text{V}, V_{CIN} = 0\text{V}, I_C = 10\text{A}, T_j = 125^\circ\text{C}$	—	2.5	3.5	Volts
Diode Forward Voltage	V_{FM}	$I_F = 10\text{A}, V_D = 15\text{V}, V_{CIN} = 5\text{V}$	—	2.5	3.5	Volts
Collector Cutoff Current	I_{CES}	$V_{CE} = V_{CES}, T_j = 25^\circ\text{C}$	—	—	1	mA
		$V_{CE} = V_{CES}, T_j = 125^\circ\text{C}$	—	—	10	mA

PM15RSH120**FLAT-BASE TYPE
INSULATED PACKAGE****Thermal Characteristics**

Characteristic	Symbol	Condition	Min.	Typ.	Max.	Units
Junction to Case Thermal Resistance	$R_{th(j-c)Q}$	Each Inverter IGBT	—	—	1.5	°C/Watt
	$R_{th(j-c)F}$	Each Inverter FWDi	—	—	4.5	°C/Watt
	$R_{th(c-f)Q}$	Each Brake IGBT	—	—	3.0	°C/Watt
	$R_{th(c-f)F}$	Each Brake FWDi	—	—	5.5	°C/Watt
Contact Thermal Resistance	$R_{th(c-f)}$	Case to Fin Per Module, Thermal Grease Applied	—	—	0.044	°C/Watt

Recommended Conditions for Use

Characteristic	Symbol	Condition	Value	Units
Supply Voltage	V_{CC}	Applied across P-N Terminals	0 ~ 800	Volts
	V_D	Applied between V_{UP1} - V_{UPC} , V_{N1} - V_{NC} , V_{VP1} - V_{VPC} , V_{WP1} - V_{WPC}	15 ± 1.5	Volts
Input ON Voltage	$V_{CIN(on)}$	Applied between	0 ~ 0.8	Volts
Input OFF Voltage	$V_{CIN(off)}$	$U_P, V_P, W_P, U_N, V_N, W_N, B_r$	$4.0 \sim V_D$	Volts
PWM Input Frequency	f_{PWM}	Using Application Circuit	5 ~ 20	kHz
Minimum Dead Time	t_{dead}	Input Signal	≥ 2.5	μs

PM15RSH120

FLAT-BASE TYPE
INSULATED PACKAGE

Inverter Part

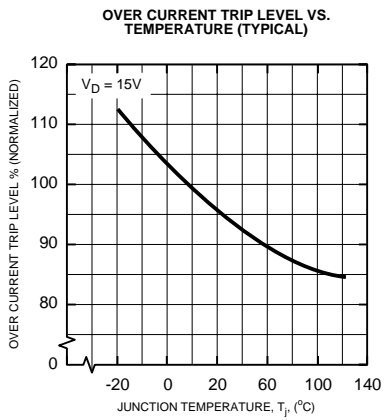
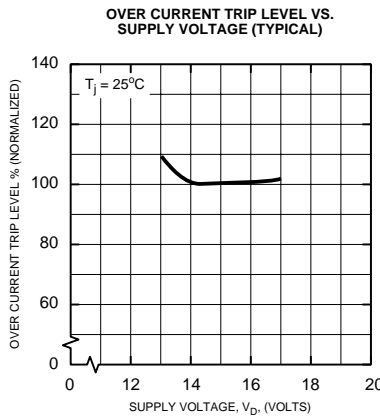
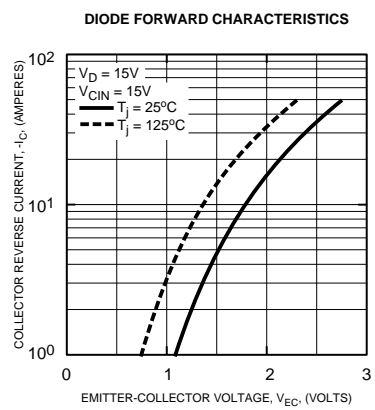
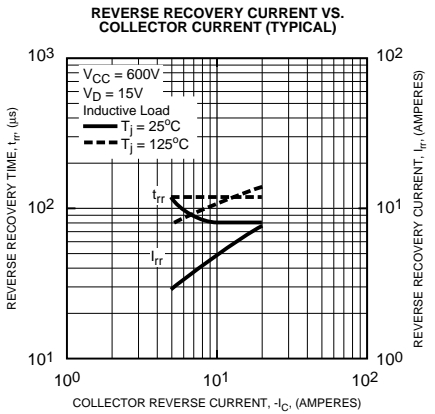
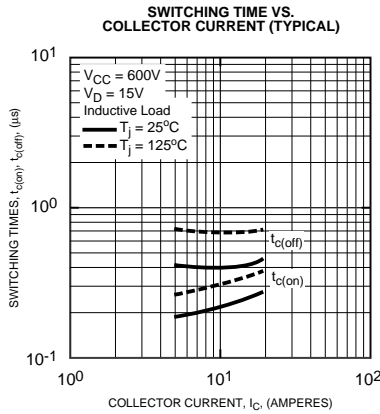
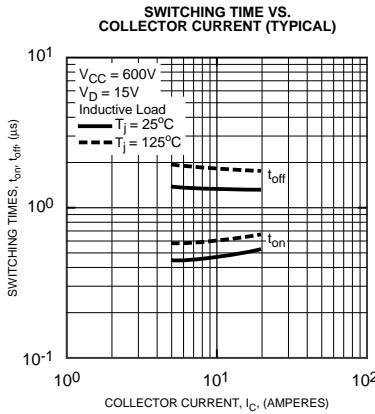
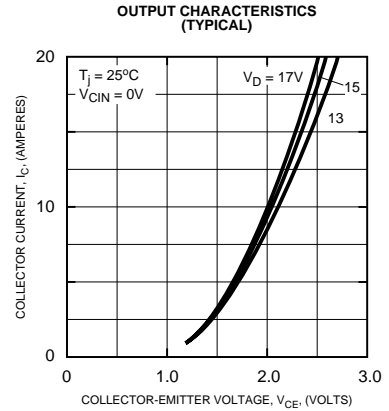
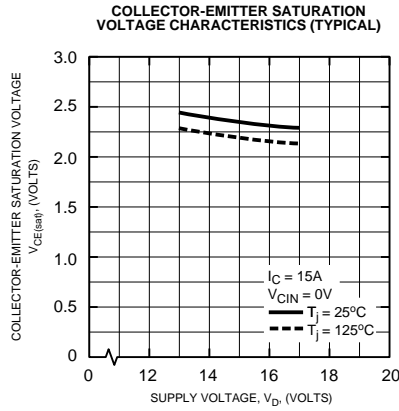
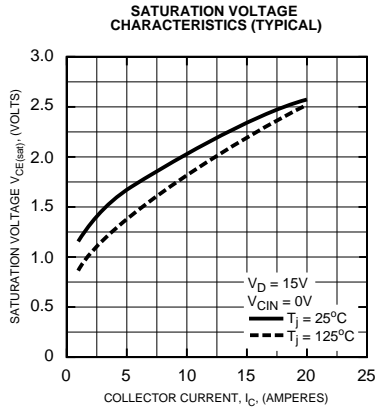

PM15RSH120

FLAT-BASE TYPE
INSULATED PACKAGE

Inverter Part

FAULT OUTPUT PULSE WIDTH VS. TEMPERATURE (TYPICAL)

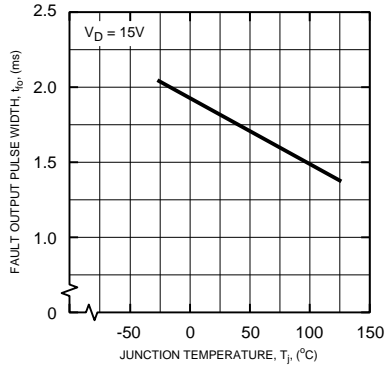

CONTROL SUPPLY VOLTAGE TRIP-RESET LEVEL TEMPERATURE DEPENDENCY (TYPICAL)

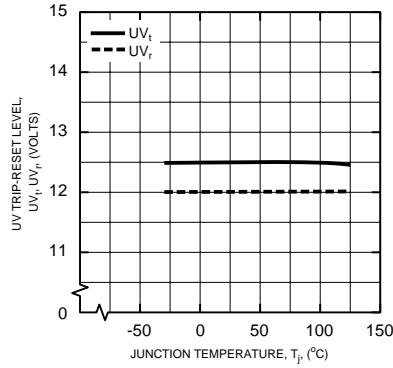

TRANSIENT THERMAL IMPEDANCE CHARACTERISTICS (Each IGBT)

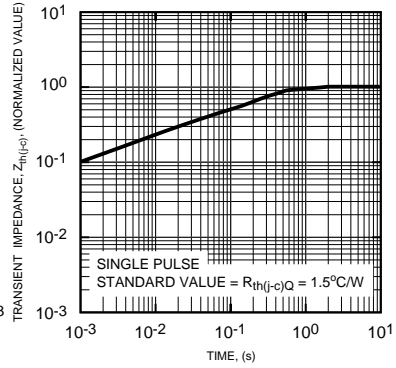

TRANSIENT THERMAL IMPEDANCE CHARACTERISTICS (Each FWD)

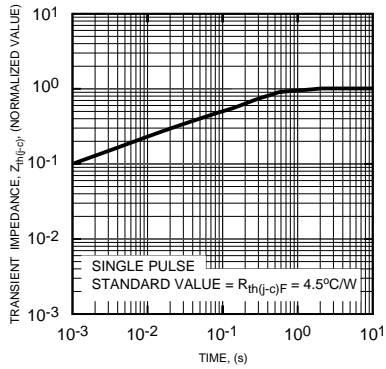

PM15RSH120

FLAT-BASE TYPE
INSULATED PACKAGE

Brake Part

