

# PS21964-T/-AT/-CT/-TW

TRANSFER-MOLD TYPE  
INSULATED TYPE

## PS21964-T

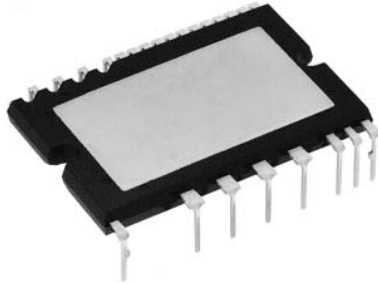

### INTEGRATED POWER FUNCTIONS

600V/15A low-loss 5<sup>th</sup> generation IGBT inverter bridge for three phase DC-to-AC power conversion

### INTEGRATED DRIVE, PROTECTION AND SYSTEM CONTROL FUNCTIONS

- For upper-leg IGBTs : Drive circuit, High voltage high-speed level shifting, Control supply under-voltage (UV) protection.
- For lower-leg IGBTs : Drive circuit, Control supply under-voltage protection (UV), Short circuit protection (SC), Over temperature protection (OT).
- Fault signaling : Corresponding to an SC fault (Lower-leg IGBT), a UV fault (Lower-side supply) or an OT fault (LVIC temperature).
- Input interface : 3V, 5V line (High Active).
- UL Approved : Yellow Card No. E80276

## APPLICATION

AC100V~200V three-phase inverter drive for small power motor control.

Fig. 1 PACKAGE OUTLINES (PS21964-T)

Dimensions in mm

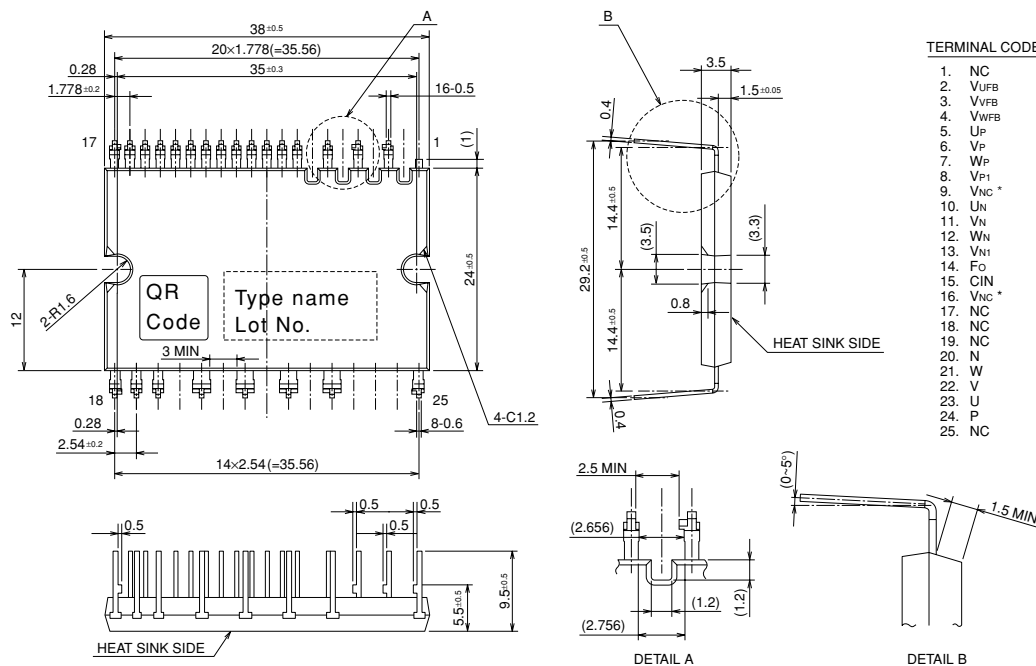

\*) Two V<sub>NC</sub> terminals (9 & 16 pin) are connected inside DIPIM, please connect either one to the 15V power supply GND outside and leave another one open.

# PS21964-T/-AT/-CT/-TW

TRANSFER-MOLD TYPE  
INSULATED TYPE

Fig. 2 LONG TERMINAL TYPE PACKAGE OUTLINES (PS21964-AT)

Dimensions in mm

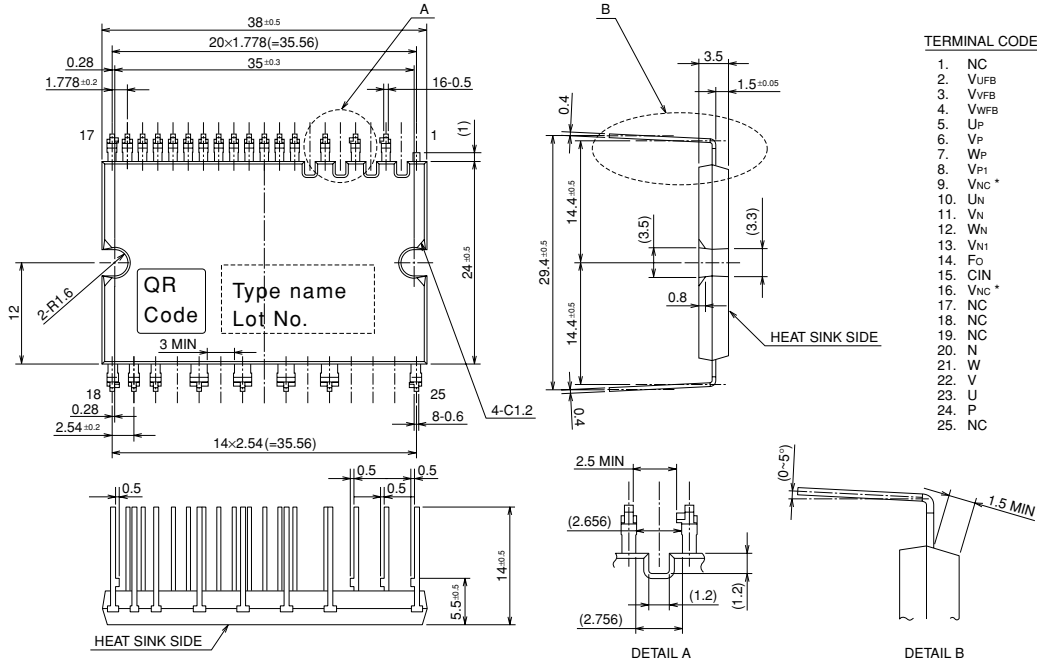

\*) Two VNC terminals (9 & 16 pin) are connected inside DIPIM, please connect either one to the 15V power supply GND outside and leave another one open.

Fig. 3 ZIGZAG TERMINAL TYPE PACKAGE OUTLINES (PS21964-CT)

Dimensions in mm

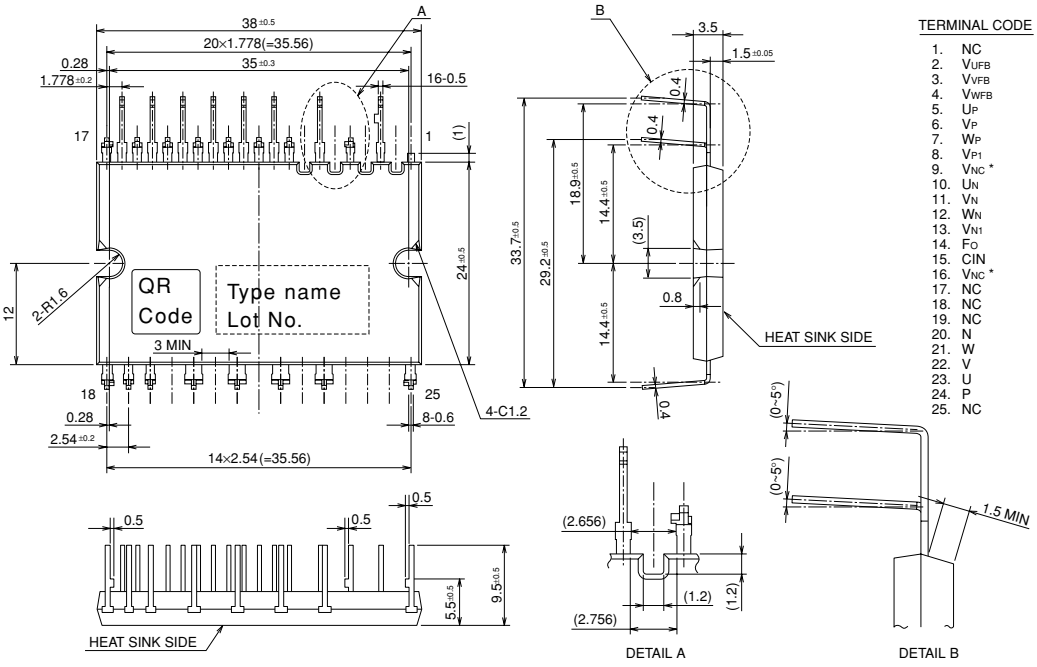

\*) Two VNC terminals (9 & 16 pin) are connected inside DIPIM, please connect either one to the 15V power supply GND outside and leave another one open.

# PS21964-T/-AT/-CT/-TW

TRANSFER-MOLD TYPE  
INSULATED TYPE

Fig. 4 BOTH SIDES ZIGZAG TERMINAL TYPE PACKAGE OUTLINES (PS21964-TW)

Dimensions in mm

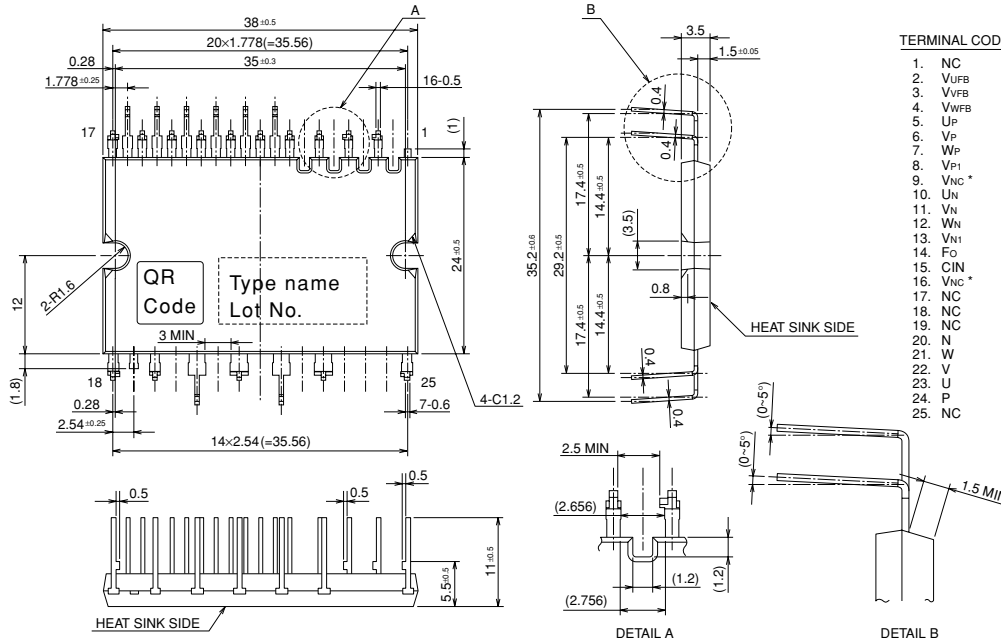

\*) Two V<sub>nc</sub> terminals (9 & 16 pin) are connected inside DIPIPM, please connect either one to the 15V power supply GND outside and leave another one open.  
QR Code is registered trademark of DENSO WAVE INCORPORATED in Japan and other countries.

Fig. 5 INTERNAL FUNCTIONS BLOCK DIAGRAM (TYPICAL APPLICATION EXAMPLE)

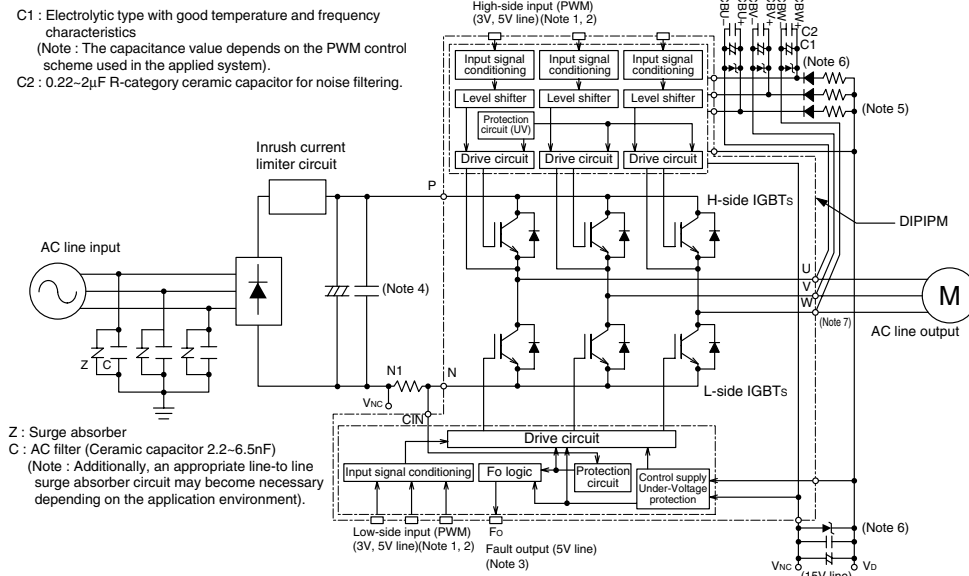

- Note1:** Input logic is high-active. There is a 3.3kΩ (min) pull-down resistor built-in each input circuit. When using an external CR filter, please make it satisfy the input threshold voltage.  
**2:** By virtue of integrating an application specific type HVIC inside the module, direct coupling to MCU terminals without any opto-coupler or transformer isolation is possible. (see also Fig. 11)  
**3:** This output is open drain type. The signal line should be pulled up to the positive side of the 5V power supply with approximately 10kΩ resistor. (see also Fig. 11)  
**4:** The wiring between the power DC link capacitor and the P, N1 terminals should be as short as possible to protect the DIPIPM against catastrophic high surge voltages. For extra precaution, a small film type snubber capacitor (0.1~0.22μF, high voltage type) is recommended to be mounted close to these P & N1 DC power input pins.  
**5:** High voltage (600V or more) and fast recovery type (less than 100ns) diodes should be used in the bootstrap circuit.  
**6:** It is recommended to insert a Zener diode (24V/1W) between each pair of control supply terminals to prevent surge destruction.  
**7:** Bootstrap negative electrodes should be connected to U, V, W terminals directly and separated from the main output wires.

# PS21964-T/-AT/-CT/-TW

TRANSFER-MOLD TYPE  
INSULATED TYPE

**Fig. 6 EXTERNAL PART OF THE DIPIPM PROTECTION CIRCUIT**

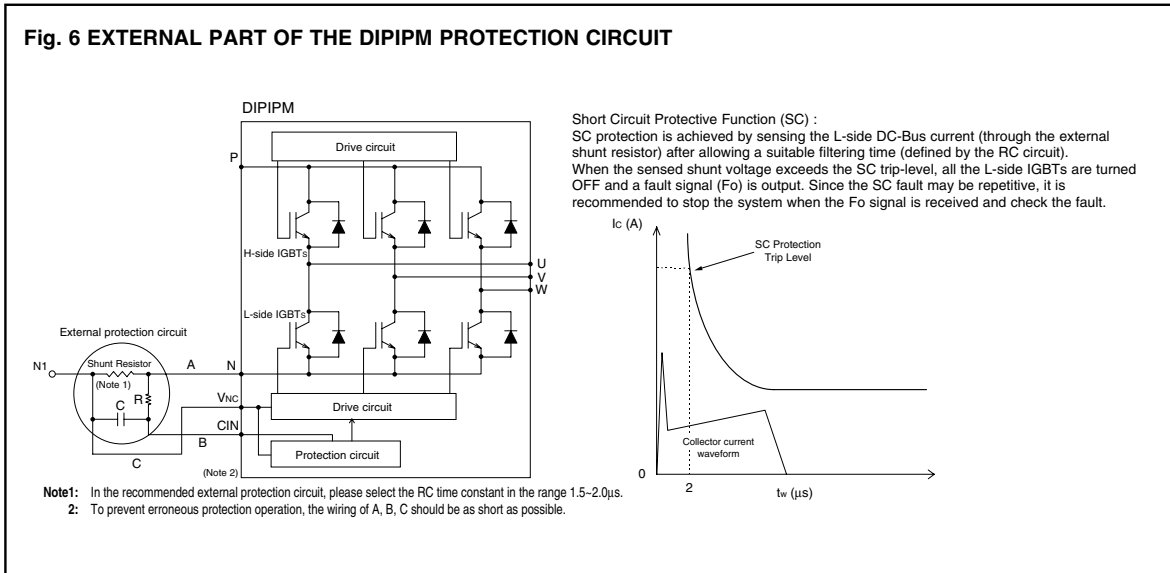

**MAXIMUM RATINGS** ( $T_j = 25^\circ\text{C}$ , unless otherwise noted)

**INVERTER PART**

| Symbol       | Parameter                          | Condition                                | Rated    | Unit             |
|--------------|------------------------------------|--|----------|------------------|
| VCC          | Supply voltage                     | Applied between P-N                      | 450      | V                |
| VCC(surge)   | Supply voltage (surge)             | Applied between P-N                      | 500      | V                |
| VCEs         | Collector-emitter voltage          |  | 600      | V                |
| $\pm I_C$    | Each IGBT collector current        | $T_C = 25^\circ\text{C}$                 | 15       | A                |
| $\pm I_{CP}$ | Each IGBT collector current (peak) | $T_C = 25^\circ\text{C}$ , less than 1ms | 30       | A                |
| PC           | Collector dissipation              | $T_C = 25^\circ\text{C}$ , per 1 chip    | 33.3     | W                |
| $T_j$        | Junction temperature               | (Note 1)                                 | -20~+125 | $^\circ\text{C}$ |

**Note 1:** The maximum junction temperature rating of the power chips integrated within the DIPIPM is  $150^\circ\text{C}$  ( $@ T_C \leq 100^\circ\text{C}$ ). However, to ensure safe operation of the DIPIPM, the average junction temperature should be limited to  $T_{j(ave)} \leq 125^\circ\text{C}$  ( $@ T_C \leq 100^\circ\text{C}$ ).

**CONTROL (PROTECTION) PART**

| Symbol | Parameter                     | Condition                                  | Rated       | Unit |
|--------|-------------------------------|--|-------------|------|
| Vd     | Control supply voltage        | Applied between VP1-VNC, VN1-VNC           | 20          | V    |
| VdB    | Control supply voltage        | Applied between VUFB-U, VVFB-V, VWFB-W     | 20          | V    |
| VIN    | Input voltage                 | Applied between UP, VP, WP, UN, VN, WN-VNC | -0.5~Vd+0.5 | V    |
| VFO    | Fault output supply voltage   | Applied between FO-VNC                     | -0.5~Vd+0.5 | V    |
| Ifo    | Fault output current          | Sink current at Fo terminal                | 1           | mA   |
| Vsc    | Current sensing input voltage | Applied between CIN-Vnc                    | -0.5~Vd+0.5 | V    |

# PS21964-T/-AT/-CT/-TW

TRANSFER-MOLD TYPE  
INSULATED TYPE

## TOTAL SYSTEM

| Symbol                 | Parameter  | Condition   | Ratings  | Unit             |
|------------------------|--|---|----------|------------------|
| V <sub>CC</sub> (PROT) | Self protection supply voltage limit (short circuit protection capability) | V <sub>D</sub> = 13.5~16.5V, Inverter part<br>T <sub>j</sub> = 125°C, non-repetitive, less than 2μs | 400      | V                |
| T <sub>C</sub>         | Module case operation temperature  | (Note 2)  | -20~+100 | °C               |
| T <sub>stg</sub>       | Storage temperature  |   | -40~+125 | °C               |
| V <sub>iso</sub>       | Isolation voltage  | 60Hz, Sinusoidal, 1 minute,<br>Between pins and heat-sink plate                                     | 1500     | V <sub>rms</sub> |

**Note 2:** T<sub>C</sub> measurement point

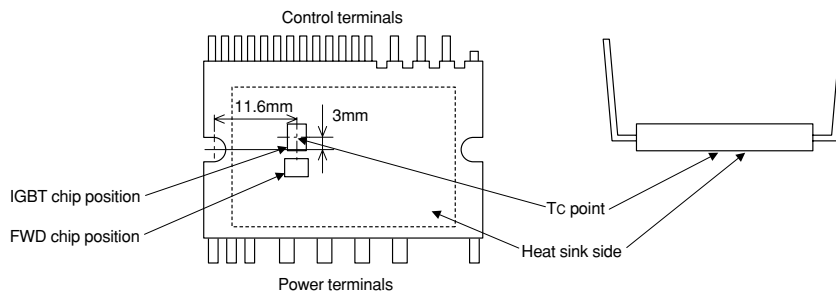

## THERMAL RESISTANCE

| Symbol                | Parameter                                    | Condition                           | Limits |      |      | Unit |
|-----------------------|--|-------------------------------------|--------|------|------|------|
|                       |  |                                     | Min.   | Typ. | Max. |      |
| R <sub>th(j-c)Q</sub> | Junction to case thermal resistance (Note 3) | Inverter IGBT part (per 1/6 module) | —      | —    | 3.0  | °C/W |
| R <sub>th(j-c)F</sub> |  | Inverter FWD part (per 1/6 module)  | —      | —    | 3.9  | °C/W |

**Note 3:** Grease with good thermal conductivity should be applied evenly with about +100μm~+200μm on the contacting surface of DIPIPM and heat-sink.

The contacting thermal resistance between DIPIPM case and heat sink (R<sub>th(c-f)</sub>) is determined by the thickness and the thermal conductivity of the applied grease. For reference, R<sub>th(c-f)</sub> (per 1/6 module) is about 0.3°C/W when the grease thickness is 20μm and the thermal conductivity is 1.0W/m·k.

## ELECTRICAL CHARACTERISTICS (T<sub>j</sub> = 25°C, unless otherwise noted)

### INVERTER PART

| Symbol               | Parameter                            | Condition  | Limits                            |                                    |      | Unit |
|----------------------|--------------------------------------|--|-----------------------------------|------------------------------------|------|------|
|                      |                                      |  | Min.                              | Typ.                               | Max. |      |
| V <sub>CE(sat)</sub> | Collector-emitter saturation voltage | V <sub>D</sub> = V <sub>DB</sub> = 15V<br>V <sub>IN</sub> = 5V   | —                                 | 1.70                               | 2.20 | V    |
|                      |                                      | I <sub>C</sub> = 15A, T <sub>j</sub> = 25°C  | —                                 | 1.80                               | 2.30 |      |
| V <sub>EC</sub>      | FWD forward voltage                  | T <sub>j</sub> = 25°C, -I <sub>C</sub> = 15A, V <sub>IN</sub> = 0V   | —                                 | 1.70                               | 2.20 | V    |
| t <sub>on</sub>      | Switching times                      | V <sub>CC</sub> = 300V, V <sub>D</sub> = V <sub>DB</sub> = 15V<br>I <sub>C</sub> = 15A, T <sub>j</sub> = 125°C, V <sub>IN</sub> = 0 ↔ 5V<br>Inductive load (upper-lower arm) | 0.70                              | 1.30                               | 1.90 | μs   |
| t <sub>rr</sub>      |                                      |  | —                                 | 0.30                               | —    | μs   |
| t <sub>c(on)</sub>   |                                      |  | —                                 | 0.50                               | 0.75 | μs   |
| t <sub>off</sub>     |                                      |  | —                                 | 1.60                               | 2.20 | μs   |
| t <sub>c(off)</sub>  |                                      |  | —                                 | 0.50                               | 0.80 | μs   |
| I <sub>CES</sub>     |                                      |  | Collector-emitter cut-off current | V <sub>CE</sub> = V <sub>CES</sub> | —    | —    |
|                      | T <sub>j</sub> = 25°C                | —  |                                   | —                                  | 10   |      |
|                      |                                      | T <sub>j</sub> = 125°C   | —                                 | —                                  | 10   |      |

# PS21964-T/-AT/-CT/-TW

TRANSFER-MOLD TYPE  
INSULATED TYPE

## CONTROL (PROTECTION) PART

| Symbol   | Parameter                                  | Condition                                   | Limits                    |      |      | Unit |    |
|----------|--|---|---------------------------|------|------|------|----|
|          |  |   | Min.                      | Typ. | Max. |      |    |
| ID       | Circuit current                            | VD = VDB = 15V<br>VIN = 5V                  | Total of VP1-VNC, VN1-VNC | —    | —    | 2.80 | mA |
|          |  |   | VUFB-U, VVFB-V, VWFB-W    | —    | —    | 0.55 | mA |
|          |  | VD = VDB = 15V<br>VIN = 0V                  | Total of VP1-VNC, VN1-VNC | —    | —    | 2.80 | mA |
|          |  |   | VUFB-U, VVFB-V, VWFB-W    | —    | —    | 0.55 | mA |
| VFOH     | Fault output voltage                       | VSC = 0V, FO terminal pull-up to 5V by 10kΩ |                           | 4.9  | —    | —    | V  |
| VFOL     |  | VSC = 1V, IFO = 1mA                         |                           | —    | —    | 0.95 | V  |
| VSC(ref) | Short circuit trip level                   | Tj = 25°C, VD = 15V                         | (Note 4)                  | 0.43 | 0.48 | 0.53 | V  |
| IIN      | Input current                              | VIN = 5V                                    |                           | 0.70 | 1.00 | 1.50 | mA |
| OTt      | Over temperature protection<br>(Note 5)    | VD = 15V,<br>At temperature of LVIC         | Trip level                | 100  | 120  | 140  | °C |
| OTrh     |  |   | Trip/reset hysteresis     | —    | 10   | —    |    |
| UVDBt    | Control supply under-voltage<br>protection | Tj ≤ 125°C                                  | Trip level                | 10.0 | —    | 12.0 | V  |
| UVDBr    |  |   | Reset level               | 10.5 | —    | 12.5 | V  |
| UVDt     |  |   | Trip level                | 10.3 | —    | 12.5 | V  |
| UVDr     |  |   | Reset level               | 10.8 | —    | 13.0 | V  |
| tFO      | Fault output pulse width                   | (Note 6)                                    |                           | 20   | —    | —    | μs |
| Vth(on)  | ON threshold voltage                       | Applied between UP, VP, WP, UN, VN, WN-VNC  |                           | —    | 2.1  | 2.6  | V  |
| Vth(off) | OFF threshold voltage                      |   |                           | 0.8  | 1.3  | —    | V  |
| Vth(hys) | ON/OFF threshold hysteresis<br>voltage     |   |                           | 0.35 | 0.65 | —    | V  |

**Note 4 :** Short circuit protection is functioning only for the lower-arms. Please select the external shunt resistance such that the SC trip-level is less than 1.7 times of the current rating.

**5 :** Over temperature protection (OT) outputs fault signal, when the LVIC temperature exceeds OT trip temperature level (OTt). In that case if the heat sink comes off DIPIM or fixed loosely, don't reuse that DIPIM. (There is a possibility that junction temperature of power chips exceeded maximum Tj (150°C)).

**6 :** Fault signal is asserted only corresponding to a SC, a UV or an OT failure at lower side, and the Fo pulse width is different for each failure modes. For SC failure, Fo output is with a fixed width of 20μsec(min), but for UV or OT failure, Fo output continuously during the whole UV or OT period, however, the minimum Fo pulse width is 20μsec(min) for very short UV or OT period less than 20μsec.

## MECHANICAL CHARACTERISTICS AND RATINGS

| Parameter          | Condition                       | Limits                 |      |      | Unit |     |
|--------------------|---------------------------------|------------------------|------|------|------|-----|
|                    |                                 | Min.                   | Typ. | Max. |      |     |
| Mounting torque    | Mounting screw : M3<br>(Note 7) | Recommended : 0.69 N·m | 0.59 | —    | 0.78 | N·m |
| Weight             |                                 |                        | —    | 10   | —    | g   |
| Heat-sink flatness |                                 | (Note 8)               | -50  | —    | 100  | μm  |

**Note 7 :** Plain washers (ISO 7089~7094) are recommended.

**Note 8 :** Flatness measurement position

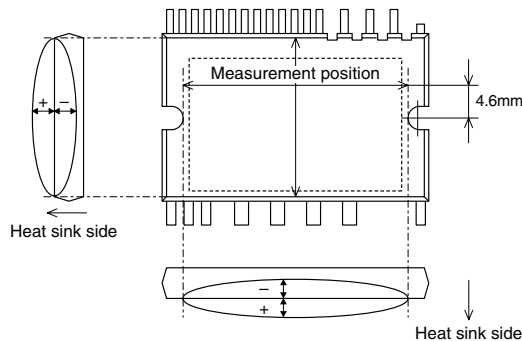

# PS21964-T/-AT/-CT/-TW

TRANSFER-MOLD TYPE  
INSULATED TYPE

## RECOMMENDED OPERATION CONDITIONS

| Symbol                  | Parameter                           | Condition  | Limits                   |      |      | Unit       |      |
|-------------------------|-------------------------------------|--|--------------------------|------|------|------------|------|
|                         |                                     |  | Min.                     | Typ. | Max. |            |      |
| VCC                     | Supply voltage                      | Applied between P-N  | 0                        | 300  | 400  | V          |      |
| Vd                      | Control supply voltage              | Applied between VP1-VNC, VN1-VNC   | 13.5                     | 15.0 | 16.5 | V          |      |
| VDB                     | Control supply voltage              | Applied between VUFB-U, VVFB-V, VWFB-W   | 13.0                     | 15.0 | 18.5 | V          |      |
| $\Delta Vd, \Delta VDB$ | Control supply variation            |  | -1                       | —    | 1    | V/ $\mu$ s |      |
| t <sub>dead</sub>       | Arm shoot-through blocking time     | For each input signal, T <sub>c</sub> ≤ 100°C  | 1.5                      | —    | —    | $\mu$ s    |      |
| f <sub>PWM</sub>        | PWM input frequency                 | T <sub>c</sub> ≤ 100°C, T <sub>j</sub> ≤ 125°C   | —                        | —    | 20   | kHz        |      |
| I <sub>o</sub>          | Allowable r.m.s. current            | V <sub>CC</sub> = 300V, V <sub>D</sub> = V <sub>DB</sub> = 15V,<br>P.F = 0.8, sinusoidal PWM,<br>T <sub>j</sub> ≤ 125°C, T <sub>c</sub> ≤ 100°C (Note 9) | f <sub>PWM</sub> = 5kHz  | —    | —    | 7.5        | Arms |
|                         |                                     |  | f <sub>PWM</sub> = 15kHz | —    | —    | 4.5        |      |
| P <sub>WIN(on)</sub>    | Allowable minimum input pulse width | (Note 10)  | 0.5                      | —    | —    | $\mu$ s    |      |
| P <sub>WIN(off)</sub>   | Allowable minimum input pulse width |  | 0.5                      | —    | —    |            |      |
| V <sub>Nc</sub>         | V <sub>Nc</sub> variation           | Between V <sub>Nc</sub> -N (including surge)   | -5.0                     | —    | 5.0  | V          |      |

**Note 9:** The allowable r.m.s. current value depends on the actual application conditions.

**10:** IPM might not make response if the input signal pulse width is less than the recommended minimum value.

Fig. 7 THE DIIPM INTERNAL CIRCUIT

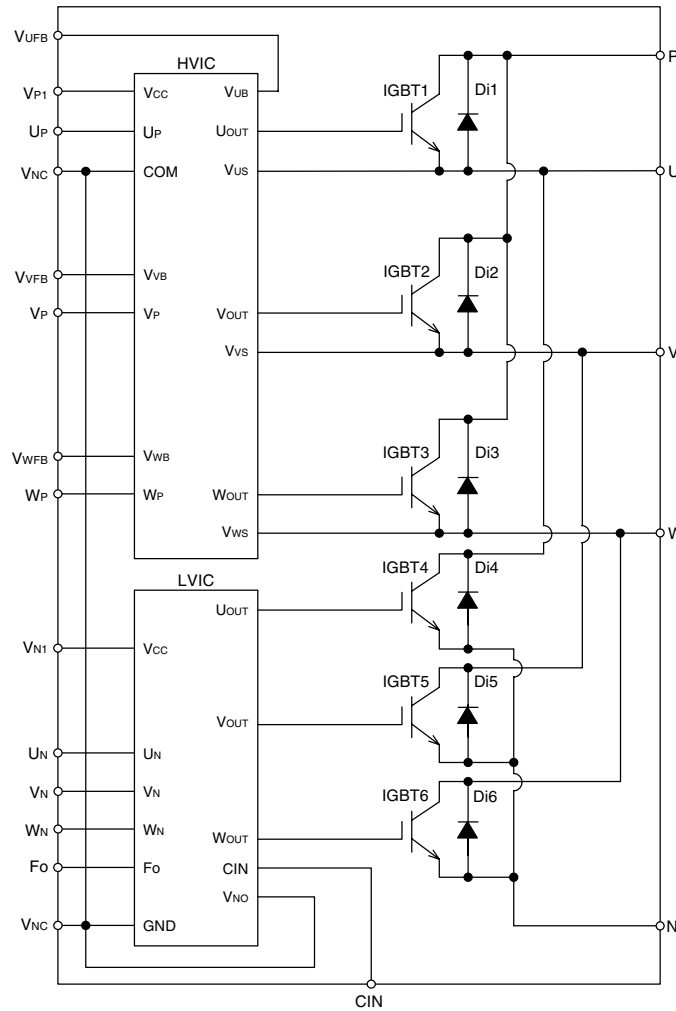

**PS21964-T/-AT/-CT/-TW**

TRANSFER-MOLD TYPE  
INSULATED TYPE

**Fig. 8 TIMING CHART OF THE DIIPM PROTECTIVE FUNCTIONS**

**[A] Short-Circuit Protection (Lower-side only with the external shunt resistor and CR filter)**

- a1. Normal operation : IGBT ON and carrying current.
- a2. Short circuit detection (SC trigger).
- a3. IGBT gate hard interruption.
- a4. IGBT turns OFF.
- a5. Fo outputs ( $t_{FO(min)} = 20\mu s$ ).
- a6. Input "L" : IGBT OFF.
- a7. Input "H" : IGBT ON.
- a8. IGBT OFF in spite of input "H".

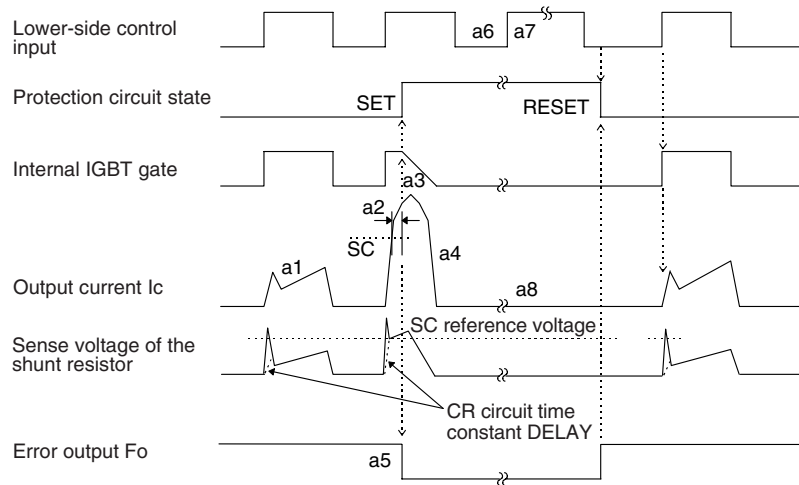

**[B] Under-Voltage Protection (Lower-side, UVd)**

- b1. Control supply voltage rising : After the voltage level reaches  $UV_{Dr}$ , the circuits start to operate when next input is applied.
- b2. Normal operation : IGBT ON and carrying current.
- b3. Under voltage trip ( $UV_{Dt}$ ).
- b4. IGBT OFF in spite of control input condition.
- b5. Fo outputs ( $t_{FO} \geq 20\mu s$  and Fo outputs continuously during UV period).
- b6. Under voltage reset ( $UV_{Dr}$ ).
- b7. Normal operation : IGBT ON and carrying current.

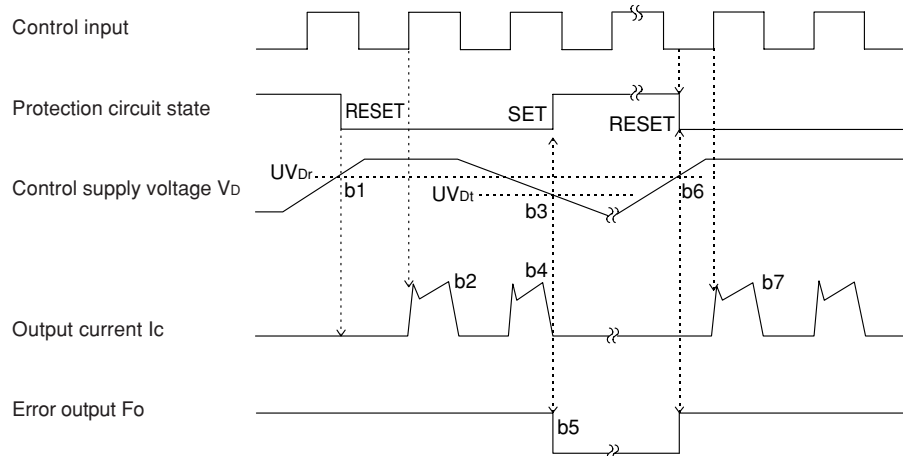



# PS21964-T/-AT/-CT/-TW

TRANSFER-MOLD TYPE  
INSULATED TYPE

### [C] Under-Voltage Protection (Upper-side, UVDB)

- c1. Control supply voltage rising : After the voltage level reaches UVDBr, the circuits start to operate when next input is applied.
- c2. Normal operation : IGBT ON and carrying current.
- c3. Under voltage trip (UVDBt).
- c4. IGBT OFF in spite of control input signal level, but there is no Fo signal outputs.
- c5. Under voltage reset (UVDBr).
- c6. Normal operation : IGBT ON and carrying current.

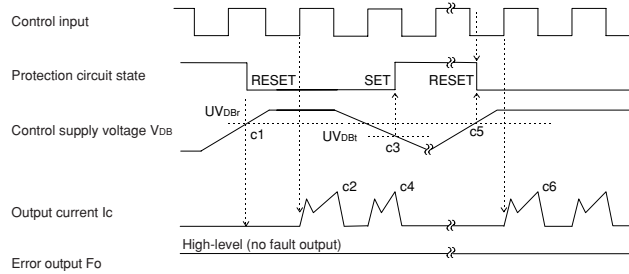

### [D] Over Temperature Protection (Lower-side, OT)

- d1. Normal operation : IGBT ON and carrying current.
- d2. LVIC temperature exceeds over temperature trip level (OT<sub>r</sub>).
- d3. IGBT OFF in spite of control input condition.
- d4. F<sub>o</sub> outputs during over temperature period, however, the minimum pulse width is 20μs.
- d5. LVIC temperature becomes under over temperature reset level.
- d6. Circuits start to operate normally when next input is applied.

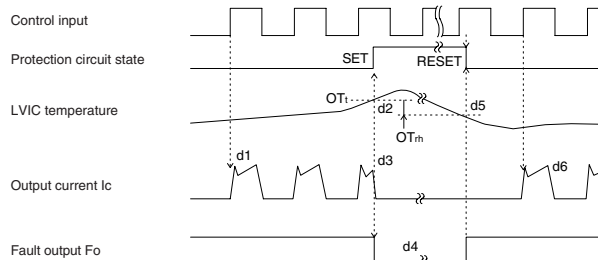
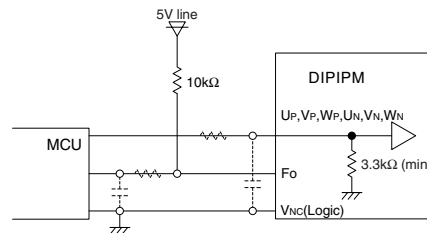
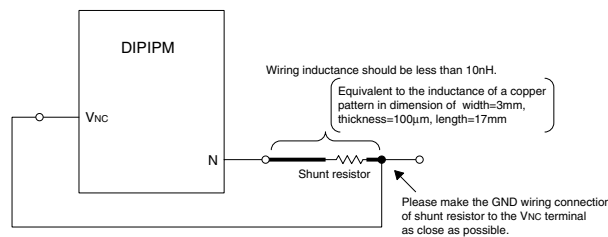

Fig. 9 RECOMMENDED MCU I/O INTERFACE CIRCUIT



**Note :** The setting of RC coupling at each input (parts shown dotted) depends on the PWM control scheme and the wiring impedance of the printed circuit board.  
The DIPIPM input section integrates a 3.3kΩ (min) pull-down resistor. Therefore, when using an external filtering resistor, pay attention to the turn-on threshold voltage.

Fig. 10 WIRING CONNECTION OF SHUNT RESISTOR



PS21964-T/-AT/-CT/-TW

TRANSFER-MOLD TYPE  
INSULATED TYPE

Fig. 11 AN EXAMPLE OF TYPICAL DIPIPM APPLICATION CIRCUIT

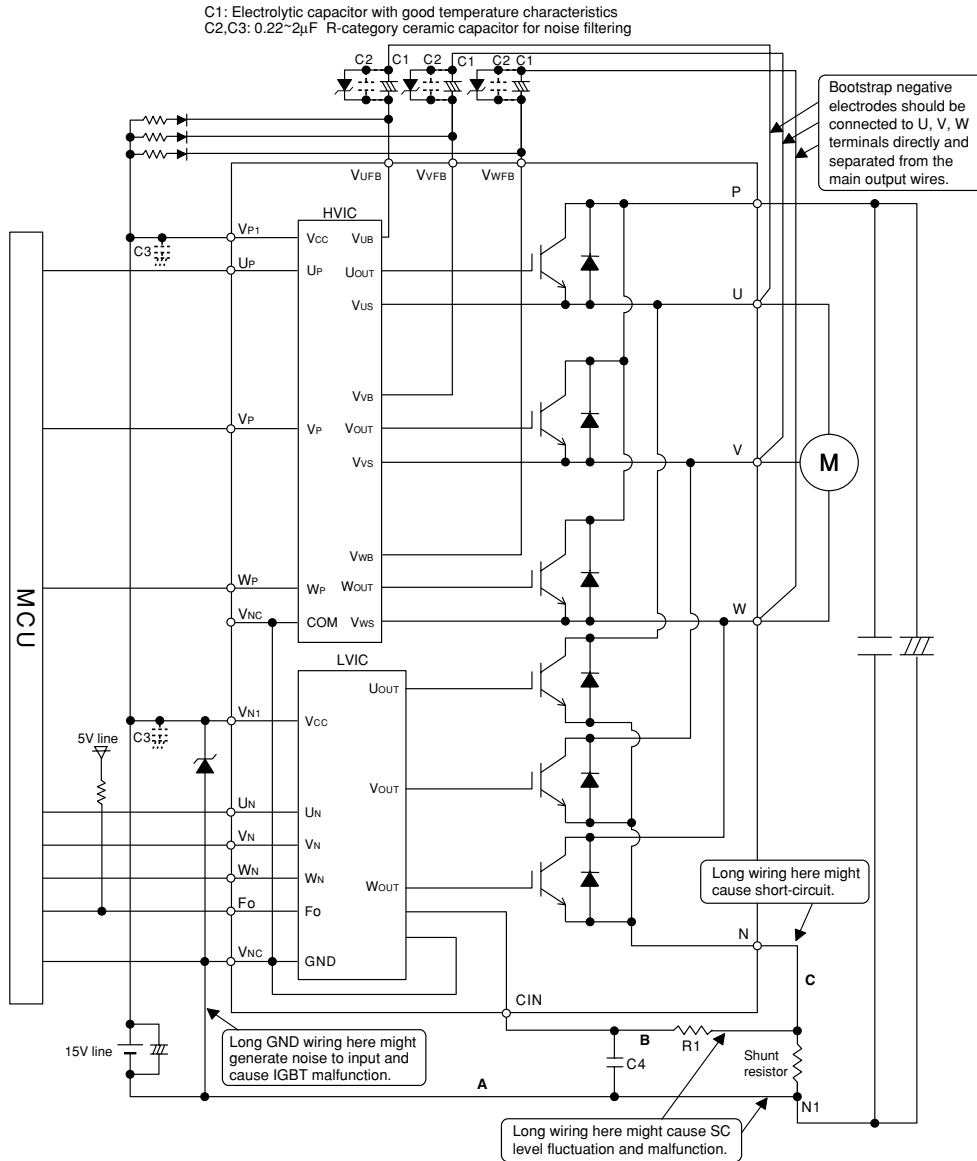

- Note 1** : Input drive is High-Active type. There is a 3.3kΩ(min.) pull-down resistor integrated in the IC input circuit. To prevent malfunction, the wiring of each input should be as short as possible. When using RC coupling circuit, make sure the input signal level meet the turn-on and turn-off threshold voltage.
- 2** : Thanks to HVIC inside the module, direct coupling to MCU without any opto-coupler or transformer isolation is possible.
- 3** : Fo output is open drain type. It should be pulled up to the positive side of a 5V power supply by a resistor of about 10kΩ.
- 4** : To prevent erroneous protection, the wiring of A, B, C should be as short as possible.
- 5** : The time constant R1C4 of the protection circuit should be selected in the range of 1.5~2μs. SC interrupting time might vary with the wiring pattern. Tight tolerance, temp-compensated type is recommended for R1, C4.
- 6** : All capacitors should be mounted as close to the terminals of the DIPIPM as possible. (C1: good temperature, frequency characteristic electrolytic type, and C2, C3: good temperature, frequency and DC bias characteristic ceramic type are recommended.)
- 7** : To prevent surge destruction, the wiring between the smoothing capacitor and the P, N1 terminals should be as short as possible. Generally a 0.1-0.22μF snubber between the P-N1 terminals is recommended.
- 8** : Two VNC terminals (9 & 16 pin) are connected inside DIPIPM, please connect either one to the 15V power supply GND outside and leave another one open.
- 9** : It is recommended to insert a Zener diode (24V/1W) between each pair of control supply terminals to prevent surge destruction.
- 10** : If control GND is connected to power GND by broad pattern, it may cause malfunction by power GND fluctuation. It is recommended to connect control GND and power GND at only a point.