



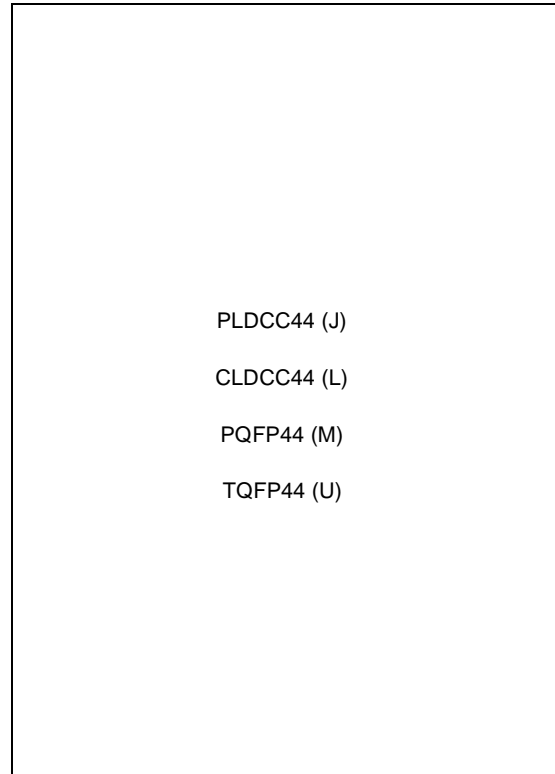
# PSD3XX ZPSD3XX ZPSD3XXV PSD3XXR ZPSD3XXR ZPSD3XXRV

## Low Cost Field Programmable Microcontroller Peripherals

### FEATURES SUMMARY

- Single Supply Voltage:
  - 5 V $\pm$ 10% for PSD3xx, ZPSD3xx, PSD3xxR, ZPSD3xxR
  - 2.7 to 5.5 V for ZPSD3xxV, ZPSD3xxRV
- Up to 1 Mbit of EPROM
- Up to 16 Kbit SRAM
- Input Latches
- Programmable I/O ports
- Page Logic
- Programmable Security

Figure 1. Packages



*PSD3XX Family*  
*PSD3XX      ZPSD3XX      ZPSD3XXV*  
*PSD3XXR    ZPSD3XXR    ZPSD3XXRV*  
*Low Cost Microcontroller Peripherals*

*Table of Contents*

1	Introduction .....	1
2	Notation .....	2
3	Key Features .....	4
4	PSD3XX Family Feature Summary .....	5
5	Partial Listing of Microcontrollers Supported .....	6
6	Applications .....	6
7	ZPSD Background .....	6
	7.1 Integrated Power Management™ Operation .....	7
8	Operating Modes (MCU Configurations) .....	10
9	Programmable Address Decoder (PAD).....	12
10	I/O Port Functions.....	15
	10.1 CSIOPORT Registers.....	15
	10.2 Port A (PA0-PA7).....	16
	10.2.1 Port A (PA0-PA7) in Multiplexed Address/Data Mode.....	16
	10.2.2 Port A (PA0-PA7) in Non-Multiplexed Address/Data Mode .....	17
	10.3 Port B (PB0-PB7).....	18
	10.3.1 Port B (PA0-PA7) in Multiplexed Address/Data Mode.....	18
	10.3.2 Port B (PA0-PA7) in Non-Multiplexed Address/Data Mode .....	19
	10.4 Port C (PC0-PC2).....	20
	10.5 ALE/AS Input Pin.....	20
11	PSD Memory .....	21
	11.1 EPROM.....	21
	11.2 SRAM (Optional).....	21
	11.3 Page Register (Optional) .....	21
	11.4 Programming and Erasure.....	21
12	Control Signals .....	22
	12.1 ALE or AS.....	22
	12.2 WR or R/W.....	22
	12.3 RD/E/DS (DS option not available on 3X1 devices) .....	22
	12.4 PSEN or PSEN.....	22
	12.5 A19/CSI .....	23
	12.6 Reset Input .....	24
13	Program/Data Space and the 8031 .....	26
14	Systems Applications.....	27
15	Security Mode.....	30
16	Power Management.....	30
	16.1 CSI Input.....	30
	16.2 CMiser Bit .....	30
	16.3 Turbo Bit (ZPSD Only).....	31
	16.4 Number of Product Terms in the PAD Logic.....	31
	16.5 Composite Frequency of the Input Signals to the PAD Logic.....	32
	16.6 Loading on I/O Pins .....	33
17	Calculating Power.....	34

# PSD3XX Family

PSD3XX      ZPSD3XX      ZPSD3XXV  
PSD3XXR    ZPSD3XXR    ZPSD3XXRV

Low Cost Microcontroller Peripherals

## Table of Contents (cont.)

---

18	Specifications.....	37
18.1	Absolute Maximum Ratings.....	37
18.2	Operating Range.....	37
18.3	Recommended Operating Conditions.....	37
18.4	Pin Capacitance.....	37
18.5	AC/DC Characteristics – PSD3XX/ZPSD3XX (All 5 V devices).....	38
18.6	AC/DC Characteristics – PSD3XXV (3 V devices only).....	39
18.7	Timing Parameters – PSD3XX/ZPSD3XX (All 5 V devices).....	40
18.8	Timing Parameters – ZPSD3XXV (3 V devices only).....	42
18.9	Timing Diagrams for PSD3XX Parts.....	44
18.10	AC Testing.....	65
19	Pin Assignments.....	66
20	Package Information.....	67
21	Package Drawings.....	68
22	PSD3XX Product Ordering Information.....	72
22.1	PSD3XX Selector Guide.....	72
22.2	Part Number Construction.....	73
22.3	Ordering Information.....	73
23	Data Sheet Revision History.....	80



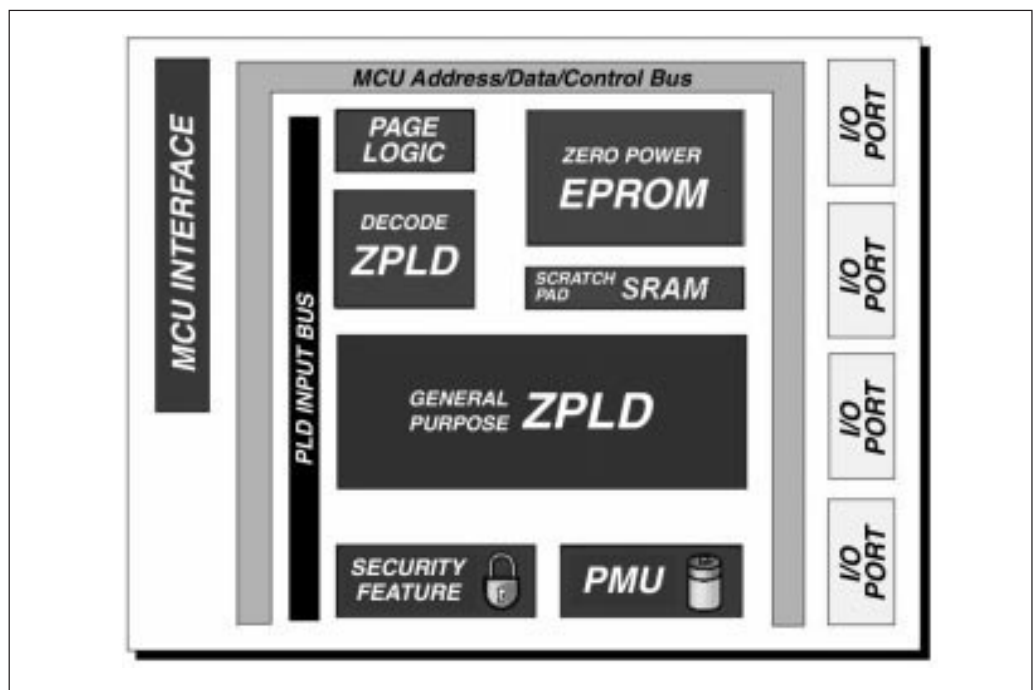
# Programmable Peripheral PSD3XX Family Field-Programmable Microcontroller Peripheral

## 1.0 Introduction

The low cost PSD3XX family integrates high-performance and user-configurable blocks of EPROM, programmable logic, and optional SRAM into one part. The PSD3XX products also provide a powerful microcontroller interface that eliminates the need for external “glue logic”. The part’s integration, small form factor, low power consumption, and ease of use make it the ideal part for interfacing to virtually any microcontroller.

The major functional blocks of the PSD3XX include:

- Two programmable logic arrays
- 256Kb to 1 Mb of EPROM
- Optional 16 Kb SRAM
- Input latches
- Programmable I/O ports
- Page logic
- Programmable security.



The PSD3XX family architecture (Figure 1) can efficiently interface with, and enhance, almost any 8- or 16-bit microcontroller system. This solution provides microcontrollers the following:

- Chip-select logic, control logic, and latched address signals that are otherwise implemented discretely
- Port expansion (reconstructs lost microcontroller I/O)
- Expanded microcontroller address space (up to 16 times)
- An EPROM (with security) and optional SRAM
- Compatible with 8031-type architectures that use separate Program and Data Space
- Interface to shared external resources.

## 1.0 Introduction (cont.)

The PSD3XX I/O ports can be used for:

- Standard I/O ports
- Programmable chip select outputs
- Address inputs
- Demultiplexed address outputs
- A data bus port for non-multiplexed MCU applications
- A data bus “repeater” port that shares and arbitrates the local MCU data bus with external devices.

Implementing your design has never been easier than with PSDsoft—ST’s software development suite. Using PSDsoft, you can do the following:

- Configure your PSD3XX to work with virtually any microcontroller
- Specify what you want implemented in the programmable logic using a high-level Hardware Description Language (HDL)
- Simulate your design
- Download your design to the part using a programmer.

## 2. Notation

For a complete product comparison, refer to Table 1.

**PSD3XX** references the standard version of the PSD3XX family, which are ideal for general-purpose embedded control applications.

**PSD3XXR** SRAM-less version of the PSD3XX. If you don’t require the 16 Kb SRAM or need a larger external SRAM, go with this part to save cost.

**ZPSD3XX** has improved technology that helps reduce current consumption using the Turbo bit. Excellent if you require a 5 V version of the PSD3XX that uses less power.

**ZPSD3XXR** SRAM-less version of the ZPSD3XX.

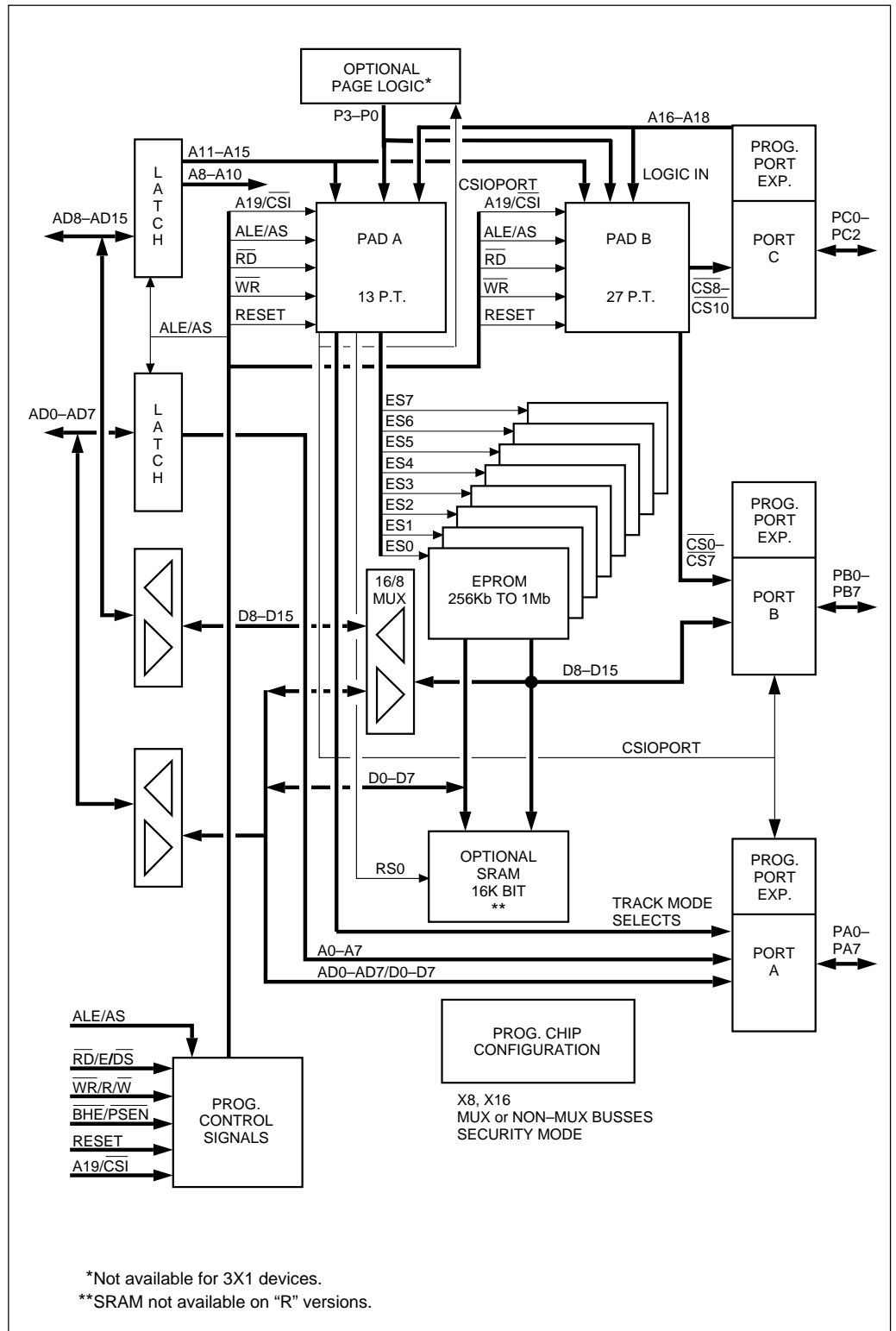
**ZPSD3XXV** 2.7 V to 5.5 V operation, ideal for very low-power and low-voltage applications.

**ZPSD3XXRV** SRAM-less version of the ZPSD3XXV.

Throughout this data sheet, references are made to the PSD3XX. In most cases, these references also cover the entire family. Exceptions will be noted. References, such as “3X1 only” cover all parts that have a 301 or 311 in the part number. Use the following table to determine what references cover which product versions:

Reference	PSD3XX	PSD3XXR	ZPSD3XX	ZPSD3XXR	ZPSD3XXV	ZPSD3XXRV
PSD3XX PSD	X	X	X	X	X	X
PSD3XX only	X	X				
Non-ZPSD	X	X				
ZPSD only ZPSD3XX			X	X	X	X
Non-V versions	X	X	X	X		
V versions only V suffix ZPSD3XXV only					X	X
SRAM-less Non-R	X		X		X	

Figure 1.  
PSD3XX  
Family  
Architecture



### 3.0 Key Features

- ❑ Single-chip programmable peripheral for microcontroller-based applications
- ❑ 256K to 1 Mbit of UV EPROM with the following features:
  - Configurable as 32, 64, or 128 K x 8; or as 16, 32, or 64 K x 16
  - Divided into eight equally-sized mappable blocks for optimized address mapping
  - As fast as 70 ns access time, which includes address decoding
- ❑ Optional 16 Kbit SRAM is configurable as 2K x 8 or 1K x 16. The access time can be as quick as 70 ns, including address decoding.
- ❑ 19 I/O pins that can be individually configured for :
  - Microcontroller I/O port expansion
  - Programmable Address decoder (PAD) I/O
  - Latched address output
  - Open-drain or CMOS output
- ❑ Two Programmable Arrays (PAD A and PAD B) replace your PLD or decoder, and have the following features:
  - Up to 18 Inputs and 24 outputs
  - 40 Product terms (13 for PAD A and 27 for PAD B)
  - Ability to decode up to 1 MB of address without paging
- ❑ Microcontroller logic that eliminates the need for external “glue logic” has the following features:
  - Ability to interface to multiplexed and non-multiplexed buses
  - Built-in address latches for multiplexed address/data bus
  - ALE and Reset polarity are programmable (Reset polarity not programmable on V-versions)
  - Multiple configurations are possible for interface to many different microcontrollers
- ❑ Optional built-in page logic expands the MCU address space by up to 16 times
- ❑ Programmable power management with standby current as low as 1µA for low-voltage version
  - CMiser bit—programmable option to reduce AC power consumption in memory
  - Turbo Bit (ZPSD only)—programmable bit to reduce AC and DC power consumption in the PADs.
- ❑ Track Mode that allows other microcontrollers or host processors to share access to the local data bus
- ❑ Built-in security locks the device and PAD decoding configuration
- ❑ Wide Operating Voltage Range
  - V-versions: 2.7 to 5.5 volts
  - Others: 4.5 to 5.5 volts
- ❑ Available in a variety of packaging (44-pin PLDCC, CLDCC, TQFP, and PQFP)
- ❑ Simple, menu-driven software (PSDsoft) allows configuration and design entry on a PC.

#### 4.0 PSD3XX Family Feature Summary

Use the following table to determine which PSD product will fit your needs. Refer back to this page whenever there is confusion as to which part has what features.

Part	# PLD Inputs	EPROM Size	SRAM Size	Page Reg	Voltage	Turbo Bit	Bus Width	Typical Standby Current
PSD301R PSD311R	14 14	256 Kb 256 Kb			5 V 5 V		x8 or x16 x8	50 $\mu$ A 50 $\mu$ A
PSD302R PSD312R	18 18	512 Kb 512 Kb		X X	5 V 5 V		x8 or x16 x8	50 $\mu$ A 50 $\mu$ A
PSD303R PSD313R	18 18	1 Mb 1 Mb		X X	5 V 5 V		x8 or x16 x8	50 $\mu$ A 50 $\mu$ A
ZPSD301R ZPSD311R	14 14	256 Kb 256 Kb			5 V 5 V	X X	x8 or x16 x8	10 $\mu$ A 10 $\mu$ A
ZPSD302R ZPSD312R	18 18	512 Kb 512 Kb		X X	5 V 5 V	X X	x8 or x16 x8	10 $\mu$ A 10 $\mu$ A
ZPSD303R ZPSD313R	18 18	1 Mb 1 Mb		X X	5 V 5 V	X X	x8 or x16 x8	10 $\mu$ A 10 $\mu$ A
PSD301 PSD311	14 14	256 Kb 256 Kb	16 Kb 16 Kb		5 V 5 V		x8 or x16 x8	50 $\mu$ A 50 $\mu$ A
PSD302 PSD312	18 18	512 Kb 512 Kb	16 Kb 16 Kb	X X	5 V 5 V		x8 or x16 x8	50 $\mu$ A 50 $\mu$ A
PSD303 PSD313	18 18	1 Mb 1 Mb	16 Kb 16 Kb	X X	5 V 5 V		x8 or x16 x8	50 $\mu$ A 50 $\mu$ A
ZPSD301 ZPSD311	14 14	256 Kb 256 Kb	16 Kb 16 Kb		5 V 5 V	X X	x8 or x16 x8	10 $\mu$ A 10 $\mu$ A
ZPSD302 ZPSD312	18 18	512 Kb 512 Kb	16 Kb 16 Kb	X X	5 V 5 V	X X	x8 or x16 x8	10 $\mu$ A 10 $\mu$ A
ZPSD303 ZPSD313	18 18	1 Mb 1 Mb	16 Kb 16 Kb	X X	5 V 5 V	X X	x8 or x16 x8	10 $\mu$ A 10 $\mu$ A
ZPSD301V <sup>1</sup> ZPSD311V <sup>1</sup>	14 14	256 Kb 256 Kb	16 Kb 16 Kb		2.7 V 2.7 V	X X	x8 or x16 x8	1 $\mu$ A 1 $\mu$ A
ZPSD302V <sup>1</sup> ZPSD312V <sup>1</sup>	18 18	512 Kb 512 Kb	16 Kb 16 Kb	X X	2.7 V 2.7 V	X X	x8 or x16 x8	1 $\mu$ A 1 $\mu$ A
ZPSD303V <sup>1</sup> ZPSD313V <sup>1</sup>	18 18	1 Mb 1 Mb	16 Kb 16 Kb	X X	2.7 V 2.7 V	X X	x8 or x16 x8	1 $\mu$ A 1 $\mu$ A

**NOTES:** 1. Low power versions of the ZPSD3XX (ZPSD3XXV) can only accept an active-low level Reset input.





## 5.0 Partial Listing of Microcontrollers Supported

- Motorola family:** 68HC11, 68HC16, M68000/10/20, M68008, M683XX, 68HC05C0
  - Intel family:** 80C31, 80C51, 80C196/198, 80C186/188
  - Philips family:** 80C31 and 80C51 based MCUs
  - Zilog:** Z8, Z80, Z180
  - National:** HPC16000, HPC46400
  - Echelon/Motorola/Toshiba:** NEURON® 3150™ Chip
- 

## 6.0 Applications

- Telecommunications:
    - Cellular phone
    - Digital PBX
    - Digital speech
    - FAX
    - Digital Signal Processing (DSP)
  - Portable Industrial Equipment:
    - Industrial control
    - Measurement meters
    - Data recorders
  - Instrumentation
  - Medical Instrumentation:
    - Hearing aids
    - Monitoring equipment
    - Diagnostic tools
  - Computers—notebooks, portable PCs, and palm-top computers:
    - Peripheral control (fixed disks, laser printers, etc.)
    - Modem Interface
    - MCU peripheral interface
- 

## 7.0 ZPSD Background

Portable and battery-powered systems have recently become major embedded control application segments. As a result, the demand for electronic components having extremely low power consumption has increased dramatically. Recognizing this trend, ST developed a new lower power 3XX part, denoted ZPSD3XX. The Z stands for Zero-power because ZPSD products virtually eliminate the DC component of power consumption, reducing it to standby levels. Virtual elimination of the DC component is the basis for the words “Zero-power” in the ZPSD name. ZPSD products also minimize the AC power component when the chip is changing states. The result is a programmable microcontroller peripheral family that replaces discrete circuit components, while drawing less power.

## 7.0 ZPSD Background (cont.)

### Integrated Power Management™ Operation

Upon each address or logic input change to the ZPSD, the device powers up from low power standby for a short time. Then the ZPSD consumes only the necessary power to deliver new logic or memory data to its outputs as a response to the input change. After the new outputs are stable, the ZPSD latches them and automatically reverts back to standby mode. The  $I_{CC}$  current flowing during standby mode and during DC operation is identical and is only a few microamperes.

The ZPSD automatically reduces its DC current drain to these low levels and does not require controlling by the CSI (Chip Select Input). Disabling the CSI pin unconditionally forces the ZPSD to standby mode independent of other input transitions.

The only significant power consumption in the ZPSD occurs during AC operation.

The ZPSD contains the first architecture to apply zero power techniques to memory and logic blocks.

Figure 2 compares ZPSD zero power operation to the operation of a discrete solution. A standard microcontroller (MCU) bus cycle usually starts with an ALE (or AS) pulse and the generation of an address. The ZPSD detects the address transition and powers up for a short time. The ZPSD then latches the outputs of the PAD, EPROM and SRAM to the new values. After finishing these operations, the ZPSD shuts off its internal power, entering standby mode. The time taken for the entire cycle is less than the ZPSD's "access time."

The ZPSD will stay in standby mode while its inputs are not changing between bus cycles. In an alternate system implementation using discrete EPROM, SRAM, and other discrete components, the system will consume operating power during the entire bus cycle. This is because the chip select inputs on the memory devices are usually active throughout the entire cycle. The AC power consumption of the ZPSD may be calculated using the composite frequency of the MCU address and control signals, as well as any other logic inputs to the ZPSD.

Figure 2. ZPSD Power Operation vs. Discrete Implementation

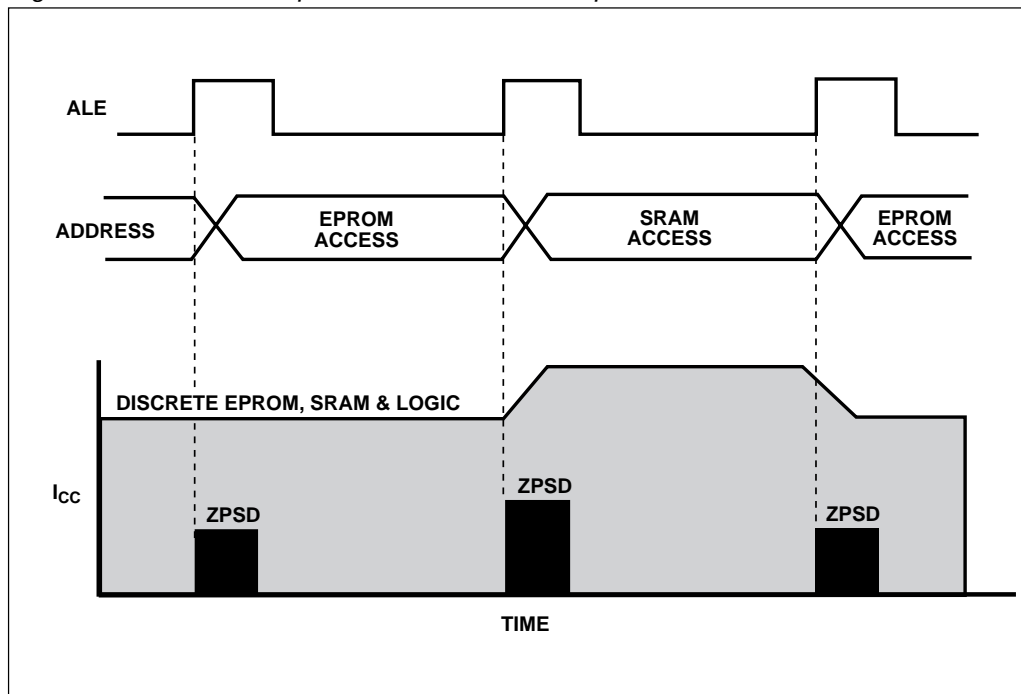


Table 2.  
PSD3XX Pin  
Descriptions

Name	Type	Description
$\overline{\text{BHE}}/\text{PSEN}$	I	<p><b>When the data bus is 8 bits:</b> This pin is for 8031 or compatible MCUs that use <math>\overline{\text{PSEN}}</math> to separate program space from data space. In this case, <math>\overline{\text{PSEN}}</math> is used for reads from the EPROM. <b>Note:</b> if your MCU does <b>not</b> output a <math>\overline{\text{PSEN}}</math> signal, pull up this pin to <math>V_{CC}</math>.</p> <p><b>When the data bus is 16 bits:</b> This pin is <math>\overline{\text{BHE}}</math>. When low, D8-D15 are read from or written to. <b>Note:</b> in programming mode, this pin is pulsed between <math>V_{PP}</math> and 0 V.</p>
$\overline{\text{WR}}/V_{PP}$ or $\text{R}/\overline{\text{W}}/V_{PP}$	I	<p>The following control signals can be connected to this port, based on your MCU (and the way you configure the PSD in PSDsoft):</p> <ol style="list-style-type: none"> <li>1. <math>\overline{\text{WR}}</math>—active-low write pulse.</li> <li>2. <math>\text{R}/\overline{\text{W}}</math>—active-high read/active-low write input.</li> </ol> <p><b>Note:</b> in programming mode, this pin <b>must</b> be tied to <math>V_{PP}</math>.</p>
$\overline{\text{RD}}/\text{E}/\overline{\text{DS}}$	I	<p>The following control signals can be connected to this port, based on your MCU (and the way you configure the PSD in PSDsoft):</p> <ol style="list-style-type: none"> <li>1. <math>\overline{\text{RD}}</math>—active-low read input.</li> <li>2. <math>\overline{\text{E}}</math>—E clock input.</li> <li>3. <math>\overline{\text{DS}}</math>—active-low data strobe input (3X2/3X3 devices only)</li> </ol>
A19/ $\overline{\text{CSI}}$	I	<p>The following control signals can be connected to this port:</p> <ol style="list-style-type: none"> <li>1. <math>\overline{\text{CSI}}</math>—Active-low chip select input. If your MCU supports a chip select output, and you want the PSD to save power when not selected, use this pin as a chip select input.</li> <li>2. If you don't wish to use the <math>\overline{\text{CSI}}</math> feature, you may use this pin as an additional input (logic or address) to the PAD. A19 can be latched (with <math>\text{ALE}/\text{AS}</math>), or a transparent logic input.</li> </ol>
Reset	I	<p><b>PSD3XX/ZPSD3XX:</b> This pin is user-programmable and can be configured to reset on a high- or low-level input. Reset must be applied for at least 100 ns.</p> <p><b>ZPSD3XXV:</b> This pin is <b>not</b> configurable, and the chip will only reset on an active-low level input. Reset must be applied for at least 500 ns, and no operations may take place for an additional 500 ns minimum. (See Figure 8.)</p>
$\text{ALE}/\text{AS}$	I	<p><b>If you use an MCU that has a multiplexed bus:</b> Connect <math>\text{ALE}</math> or <math>\text{AS}</math> to this pin. The polarity of this pin is configurable. The trailing edge of <math>\text{ALE}/\text{AS}</math> latches all multiplexed address inputs (and <math>\overline{\text{BHE}}</math> where applicable).</p> <p><b>If you use an MCU that does not have a multiplexed bus:</b> If your MCU uses <math>\text{ALE}/\text{AS}</math>, connect the signal to this pin. Otherwise, use this pin for a generic logic input to the PAD. (Non-3X1 devices only.)</p>
PA0 PA1 PA2 PA3 PA4 PA5 PA6 PA7	I/O	<p>These pins make up Port A. These port pins are configurable, and can have the following functions: (see Figure 5A and 5B)</p> <ol style="list-style-type: none"> <li>1. Track AD7-AD0. This feature repeats the MCU address and data bus on all Port A pins.</li> <li>2. MCU I/O—in this mode, the direction of the pin is defined by its direction bit, which resides in the direction register.</li> <li>3. Latched address output.</li> <li>4. CMOS or open-drain output.</li> <li>5. <b>If your MCU is non-multiplexed:</b> data bus input—connect your data bus (D0-7) to these pins. See Figure 3.</li> </ol>

Legend: The Type column abbreviations are: I = input only; I/O = input/output; P = power.



Table 2.  
PSD3XX Pin  
Descriptions  
(cont.)

Name	Type	Description
PB0 PB1 PB2 PB3 PB4 PB5 PB6 PB7	I/O	These pins make up Port B. These port pins are configurable, and can have the following functions: (see Figure 6) 1. MCU I/O—in this mode, the direction of the pin is defined by its direction bit, which resides in the direction register. 2. Chip select output—each of PB0-3 has four product terms available per pin, while PB4-7 have 2 product terms each. See Figure 4. 3. CMOS or open-drain. 4. <b>If your MCU is non-multiplexed, and the data bus width is 16 bits:</b> data bus input—connect your data bus (D8-D15) to these pins. See Figure 3.
PC0 PC1 PC2	I/O	These pins make up Port C. These port pins are configurable, and can have the following functions (see Figure 7): 1. PAD input—when configured as an input, a bit individually becomes an address or a logic input, depending on your PSDsoft design file. When declared as an address, the bit(s) can be latched with ALE/AS. 2. PAD output—when configured as an output (i.e. there is an equation written for it in your PSDsoft design file), there is one product term available to it.
AD0/A0 AD1/A1 AD2/A2 AD3/A3 AD4/A4 AD5/A5 AD6/A6 AD7/A7	I/O	<b>If your MCU is multiplexed:</b> These pins are the multiplexed, low-order address/data byte (AD0-AD7). As inputs, address information is latched by the ALE/AS signal and used internally by the PSD. The pins also serve as MCU data bus inputs or outputs, depending on the MCU control signals ( $\overline{RD}$ , $\overline{WR}$ , etc.). <b>If your MCU is non-multiplexed:</b> These pins are the low-order address inputs (A0-A7)
AD8/A8 AD9/A9 AD10/A10 AD11/A11 AD12/A12 AD13/A13 AD14/A14 AD15/A15	I/O	<b>If your MCU is multiplexed with a 16-bit data bus:</b> These pins are the multiplexed, high-order address/data byte (AD8-AD15). As inputs, address information is latched by the ALE/AS signal and used internally the PSD. The pins also serve as MCU data bus inputs or outputs, depending on the MCU control signals ( $\overline{RD}$ , $\overline{WR}$ , etc.). <b>If your MCU is non-multiplexed or has a 8-bit data bus:</b> These pins are the high-order address inputs (A8-A15).
GND	P	Ground Pin
V <sub>CC</sub>	P	Supply voltage input.

*Legend:* The Type column abbreviations are: I = input only; I/O = input/output; P = power.

## 8.0 Operating Modes (MCU Configurations)

The PSD3XX's four operating modes enable it to interface directly to most 8- and 16-bit microcontrollers with multiplexed and non-multiplexed address/data busses. The 16-bit modes are not available to some devices; see Table 1. The following are the four operating modes available:

- Multiplexed 8-bit address/data bus
- Multiplexed 16-bit address/data bus
- Non-multiplexed 8-bit data bus
- Non-multiplexed 16-bit data bus

Please read the section below that corresponds to your type of MCU. Then check the appropriate Figure (3A/3B/3C/3D) to determine your pin connections. Table 3 lists the Port connections in tabular form.

### *Multiplexed 8-bit address/data bus (Figure 3A)*

This mode is used to interface to microcontrollers with a multiplexed 8-bit data bus. Since the low-order address and data are multiplexed together, your MCU will output an ALE or AS signal. The PSD3XX contains a transparent latch to demultiplex the address/data lines internally. All you have to do is connect the ALE/AS signal and select 8-bit multiplexed bus mode in PSDsoft. If your MCU outputs more than 16 bits of address, and you wish to connect them to the PSD, connect A16-A18 to Port C and A19 to A19/ $\overline{\text{CS}}$ , where applicable.

### *Multiplexed 16-bit address/data bus (Figure 3B)*

This mode is used to interface to microcontrollers with a multiplexed 16-bit data bus. Since the low address bytes and data are multiplexed together, your MCU will output an ALE or AS signal. The PSD3XX contains a transparent latch to demultiplex the address/data lines internally. All you have to do is connect the ALE/AS signal and select 8-bit multiplexed bus mode in PSDsoft. If your MCU outputs more than 16 bits of address, and you wish to connect them to the PSD, connect A16-A18 to Port C and A19 to A19/ $\overline{\text{CS}}$ , where applicable.

### *Non-multiplexed 8-bit data bus (Figure 3C)*

This mode is used to interface to microcontrollers with a non-multiplexed 8-bit data bus. Connect the MCU's address bus to AD0/A0-AD15/A15 on the PSD. Connect the data bus signals of your MCU to Port A of the PSD. If your MCU outputs more than 16 bits of address, and you wish to connect them to the PSD, connect A16-A18 to Port C and A19 to A19/ $\overline{\text{CS}}$ , where applicable.

### *Non-multiplexed 16-bit data bus (Figure 3D)*

This mode is used to interface to microcontrollers with a non-multiplexed 16-bit data bus. Connect the MCU's address bus to AD0/A0-AD15/A15 on the PSD. Connect the low byte data bus signals of your MCU to Port A, and the high byte data output of your MCU to Port B of the PSD. If your MCU outputs more than 16 bits of address, and you wish to connect them to the PSD, connect A16-A18 to Port C and A19 to A19/ $\overline{\text{CS}}$ , where applicable.

**For users with multiplexed MCUs that have data multiplexed on address lines other than A0-A7 note:** You can still use the PSD3XX, but you will have to connect your data to Port A (and Port B where required), as shown in Figure 3C or 3D. That is, you will be connecting it as if you were using a non-multiplexed MCU. In this case, you must connect the ALE/AS signal so that the address will still be properly latched. This option is not available on the 3X1 versions.

8.0  
Operating Modes  
(MCU  
Configurations)  
(cont.)

Figure 3A. Connecting a PSD3XX to an 8-Bit Multiplexed-Bus MCU

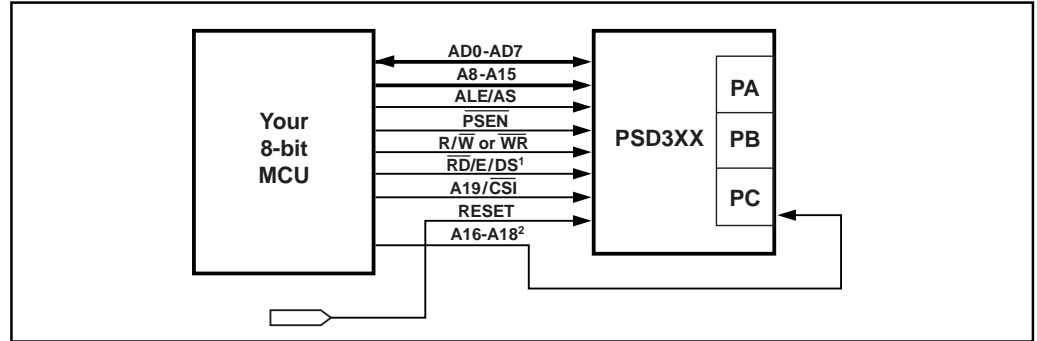


Figure 3B. Connecting a PSD3XX to a 16-Bit Multiplexed-Bus MCU

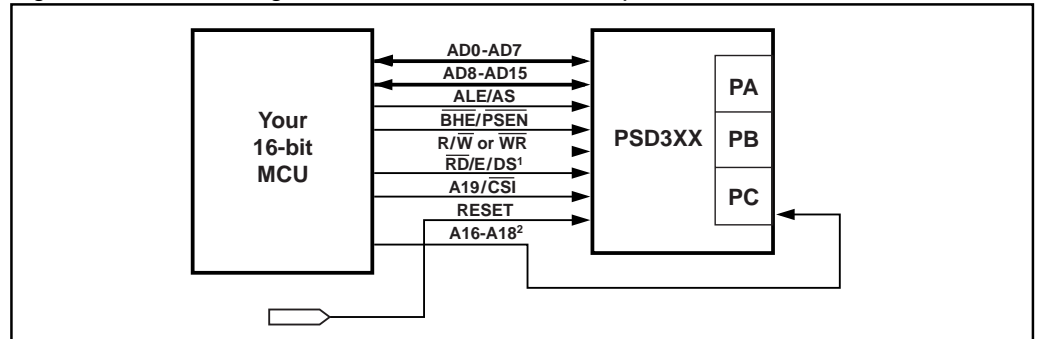


Figure 3C. Connecting a PSD3XX to an 8-Bit Non-Multiplexed-Bus MCU

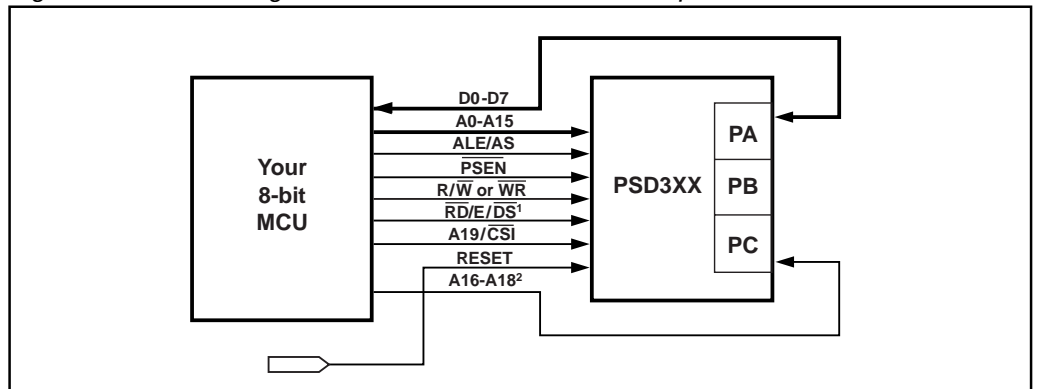
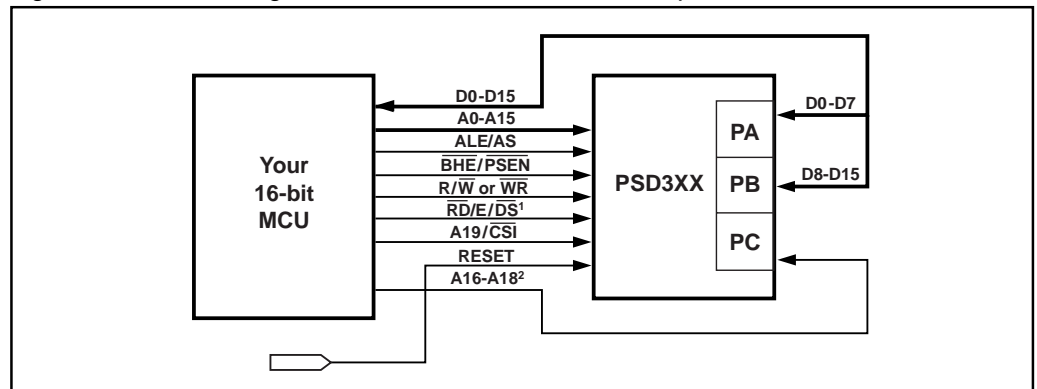


Figure 3D. Connecting a PSD3XX to a 16-Bit Non-Multiplexed-Bus MCU



NOTES: 1.  $\overline{DS}$  is a valid input on 3X2/3X3 and devices only.  
2. Connect A16-A18 to Port C if your MCU outputs more than 16 bits of address.



## 8.0 Operating Modes (MCU Configurations) (cont.)

Table 3. Bus and Port Configuration Options

	Multiplexed Address/Data	Non-Multiplexed Address/Data
<i>8-bit Data Bus</i>		
Port A	I/O or low-order address lines or Low-order multiplexed address/data byte	D0–D7 data bus byte
Port B	I/O and/or $\overline{CS0}$ – $\overline{CS7}$	I/O and/or $\overline{CS0}$ – $\overline{CS7}$
AD0/A0–AD7/A7	Low-order multiplexed address/data byte	Low-order address bus byte
AD8/A8–AD15/A15	High-order address bus byte	High-order address bus byte
<i>16-bit Data Bus</i>		
Port A	I/O or low-order address lines or low-order multiplexed address/data byte	Low-order data bus byte
Port B	I/O and/or $\overline{CS0}$ – $\overline{CS7}$	High-order data bus byte
AD0/A0–AD7/A7	Low-order multiplexed address/data byte	Low-order address bus byte
AD8/A8–AD15/A15	High-order multiplexed address/data byte	High-order address bus byte

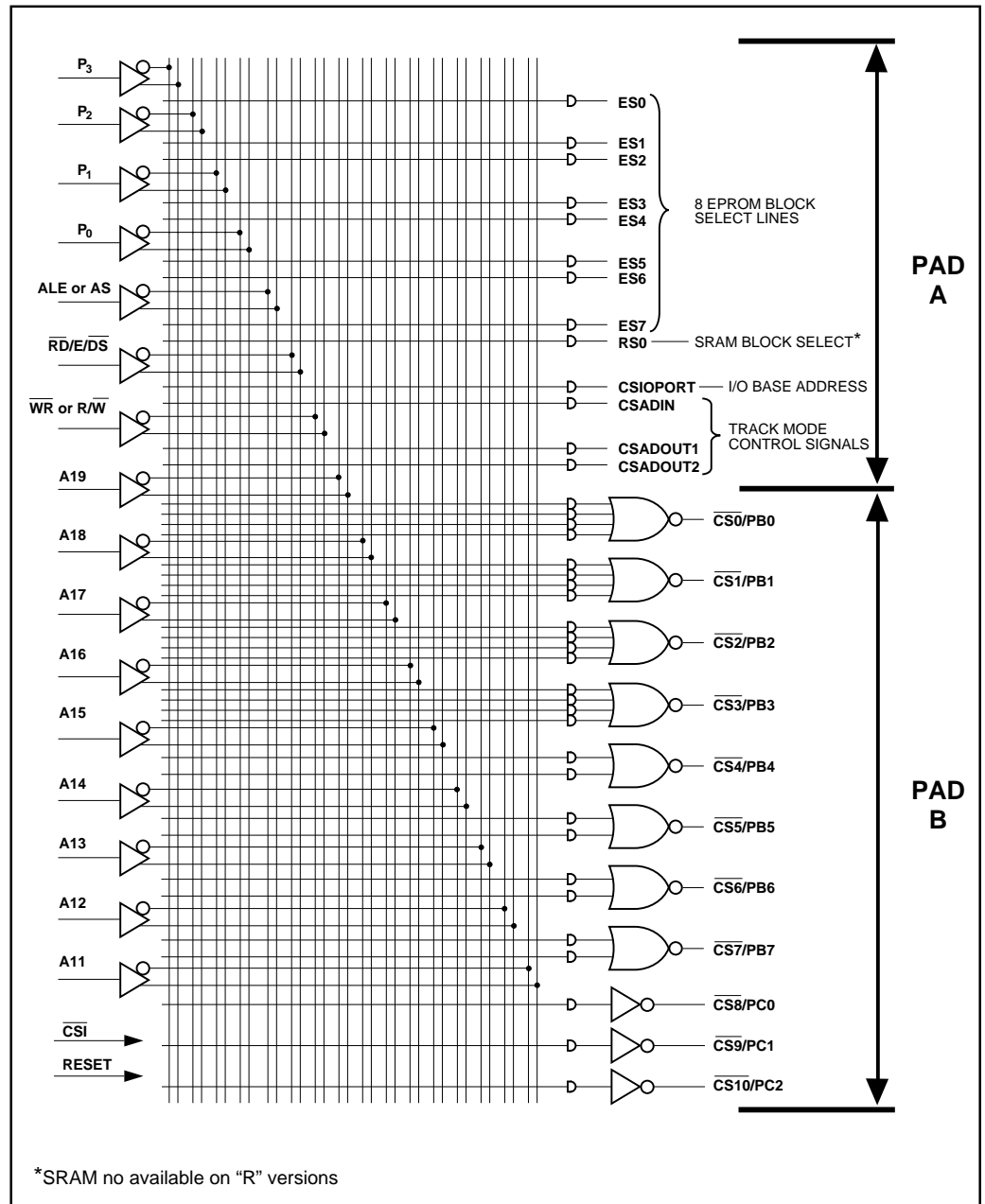
## 9.0 Programmable Address Decoder (PAD)

The PSD3XX contains two programmable arrays, referred to as PAD A and PAD B (Figure 4). PAD A is used to generate chip select signals derived from the input address to the internal EPROM blocks, SRAM, I/O ports, and Track Mode signals.

PAD B outputs to Ports B and C for off-chip usage. PAD B can also be used to extend the decoding to select external devices or as a random logic replacement.

PAD A and PAD B receive the same inputs. The PAD logic is configured by PSDsoft based on the designer's input. The PAD's non-volatile configuration is stored in a re-programmable CMOS EPROM. Windowed packages are available for erasure by the user. See Table 4 for a list of PAD A and PAD B functions.

Figure 4.  
PAD Description



- NOTES:**
1.  $\overline{CSi}$  is a power-down signal. When high, the PAD is in stand-by mode and all its outputs become non-active. See Tables 12 and 13.
  2. RESET deselects all PAD output signals. See Tables 10 and 11.
  3. A<sub>18</sub>, A<sub>17</sub>, and A<sub>16</sub> are internally multiplexed with  $\overline{CS10}$ ,  $\overline{CS9}$ , and  $\overline{CS8}$ , respectively. Either A<sub>18</sub> or CS<sub>10</sub>, A<sub>17</sub> or CS<sub>9</sub>, and A<sub>16</sub> or CS<sub>8</sub> can be routed to the external pins of Port C. Port C pins can be configured as either input or output, individually.
  4. P<sub>0</sub>-P<sub>3</sub> are not included on 3X1 devices.
  5.  $\overline{DS}$  is not available on 3X1 devices.



Table 4.  
PSD3XX  
PAD A and  
PAD B  
Functions

<i>Function</i>	
<i>PAD A and PAD B Inputs</i>	
A19/ $\overline{\text{CS}}\text{I}$	When the PSD is configured to use $\overline{\text{CS}}\text{I}$ and while $\overline{\text{CS}}\text{I}$ is a logic 1, the PAD deselects all of its outputs and enters a power-down mode (see Tables 12 and 13). When the PSD is configured to use A19, this signal is another input to the PAD.
A16–A18	These are general purpose inputs from Port C. See Figure 4, Note 3.
A11–A15	These are address inputs.
P0–P3	These are inputs from the page register (not available on 3X1 versions).
$\overline{\text{RD}}/\text{E}/\overline{\text{DS}}$	This is the read pulse or strobe input. ( $\overline{\text{DS}}$ not available on 3X1 versions).
$\overline{\text{WR}}$ or $\text{R}/\overline{\text{W}}$	This is the write pulse or $\text{R}/\overline{\text{W}}$ select signal.
ALE/AS	This is the ALE or AS input to the chip. Use to demultiplex address and data.
RESET	This deselects all outputs from the PAD; it can not be used in product term equations. See Tables 10 and 11.
<i>PAD A Outputs</i>	
ES0–ES7	These are internal chip-selects to the 8 EPROM banks. Each bank can be located on any boundary that is a function of one product term of the PAD address inputs.
RS0	This is an internal chip-select to the SRAM. Its base address location is a function of one term of the PAD address inputs.
CSIOPORT	This internal chip-select selects the I/O ports. It can be placed on any boundary that is a function of one product term of the PAD inputs. See Tables 5A and 5B.
CSADIN	This internal chip-select, when Port A is configured as a low-order address/data bus in the track mode controls the input direction of Port A. CSADIN is gated externally to the PAD by the internal read signal. When CSADIN and a read operation are active, <b>data presented on Port A flows out of AD0/A0–AD7/A7</b> . This chip-select can be placed on any boundary that is a function of one product term of the PAD inputs. See Figure 5B.
CSADOUT1	This internal chip-select, when Port A is configured as a low-order address/data bus in track mode, controls the output direction of Port A. CSADOUT1 is gated externally to the PAD by the ALE signal. When CSADOUT1 and the ALE signal are active, the <b>address presented on AD0/A0–AD7/A7 flows out of Port A</b> . This chip-select can be placed on any boundary that is a function of one product term of the PAD inputs. See Figure 5B.
CSADOUT2	This internal chip-select, when Port A is configured as a low-order address/data bus in the track mode, controls the output direction of Port A. CSADOUT2 must include the write-cycle control signals as part of its product term. When CSADOUT2 is active, the <b>data presented on AD0/A0–AD7/A7 flows out of Port A</b> . This chip-select can be placed on any boundary that is a function of one product term of the PAD inputs. See Figure 5B.
<i>PAD B Outputs</i>	
CS0–CS3	These chip-select outputs can be routed through Port B. Each of them is a function of up to four product terms of the PAD inputs.
CS4–CS7	These chip-select outputs can be routed through Port B. Each of them is a function of up to two product terms of the PAD inputs.
CS8–CS10	These chip-select outputs can be routed through Port C. See Figure 4, Note 3. Each of them is a function of one product term of the PAD inputs.



## 10.0 I/O Port Functions

The PSD3XX has three I/O ports (Ports A, B, and C) that are configurable at the bit level. This permits great flexibility and a high degree of customization for specific applications. The next section describes the control registers for the ports. Following that are sections that describe each port. Figures 5 through 7 show the structure of Ports A through C, respectively.

**Note:** any unused input should be connected directly to ground or pulled up to  $V_{CC}$  (using a 10K $\Omega$  to 100K $\Omega$  resistor).

### 10.1 CSIOPORT Registers

Control of the ports is primarily handled through the CSIOPORT registers. There are 24 bytes in the address space, starting at the base address labeled CSIOPORT. Since the PSD3XX uses internal address lines A15-A8 for decoding, the CSIOPORT space will occupy 2 Kbytes of memory, on a 2 Kbyte boundary. This resolution can be improved to reduce wasted address space by connecting lower order address lines (A7 and below) to Port C. Using this method, resolution down to 256 Kbytes may be achieved. The CSIOPORT space **must be defined in your PSDsoft design file**. The following tables list the registers located in the CSIOPORT space.

#### 16-Bit Users Note

When referring to Table 5B, realize that Ports A and B are still accessible on a byte basis.

**Note: When accessing Port B on a 16-bit data bus, BHE must be low.**

Table 5A. CSIOPORT Registers for 8-Bit Data Busses

Register Name	Offset (in hex) from CSIOPORT Base Address	Type of Access Allowed
Port A Pin Register	+2	Read
Port A Direction Register	+4	Read/Write
Port A Data Register	+6	Read/Write
Port B Pin Register	+3	Read
Port B Direction Register	+5	Read/Write
Port B Data Register	+7	Read/Write
Power Management Register (Note 1)	+10	Read/Write
Page Register	+18	Read/Write

**NOTE:** 1. ZPSD only.

Table 5B. CSIOPORT Registers for 16-Bit Data Busses

Register Name	Offset (in hex) from CSIOPORT Base Address	Type of Access Allowed
Port A/B Pin Register	+2	Read
Port A/B Direction Register	+4	Read/Write
Port A/B Data Register	+6	Read/Write
Power Management Register (Note 1)	+10	Read/Write
Page Register	+18	Read/Write

**NOTE:** 1. ZPSD only.



## 10.0 I/O Port Functions (cont.)

### 10.2 Port A (PA0-PA7)

The control registers of Port A are located in CSIOPORT space; see Table 5.

#### 10.2.1 Port A (PA0-PA7) in Multiplexed Address/Data Mode

Each pin of Port A can be individually configured. The following table summarizes what the control registers (in CSIOPORT space) for Port A do:

Register Name	0 Value	1 Value	Default Value (Note 1)
Port A Pin Register	Sampled logic level at pin = '0'	Sampled logic level at pin = '1'	X
Port A Direction Register	Pin is configured as input	Pin is configured as output	0
Port A Data Register	Data in DFF = '0'	Data in DFF = '1'	0

**NOTE:** 1. Default value is the value after reset.

#### MCU I/O Mode

The default configuration of Port A is MCU I/O. In this mode, every pin can be set (at run-time) as an input or output by writing to the respective pin's direction flip-flop (DIR FF, Figure 5A). As an output, the pin level can be controlled by writing to the respective pin's data flip-flop (DFF, Figure 5A). The Pin Register can be read to determine logic level of the pin. The contents of the Pin Register indicate the true state of the PSD driving the pin through the DFF or an external source driving the pin. Pins can be configured as CMOS or open-drain using ST's PSDsoft software. Open-drain pins require external pull-up resistors.

#### Latched Address Output Mode

Alternatively, any bit(s) of Port A can be configured to output low-order demultiplexed address bus bit. The address is provided by the internal PSD address latch, which latches the address on the trailing edge of ALE/AS. Port A then outputs the desired demultiplexed address bits. This feature can eliminate the need for an external latch (for example: 74LS373) if you have devices that require low-order latched address bits. Although any pin of Port A may output an address signal, the pin is position-dependent. In other words, pin PA0 of Port A may only pass A0, PA1 only A1, and so on.

#### Track Mode

Track Mode sets the entire port to track the signals on AD0/A0-AD7/A7, depending on specific address ranges defined by the PAD's CSADIN, CSADOUT1, and CSADOUT2 signals. This feature lets the user interface the microcontroller to shared external resources without requiring external buffers and decoders. In Track Mode, Port A effectively operates as a bi-directional buffer, allowing external MCUs or host processors to access the local data bus. Keep the following information in mind when setting up Track Mode:

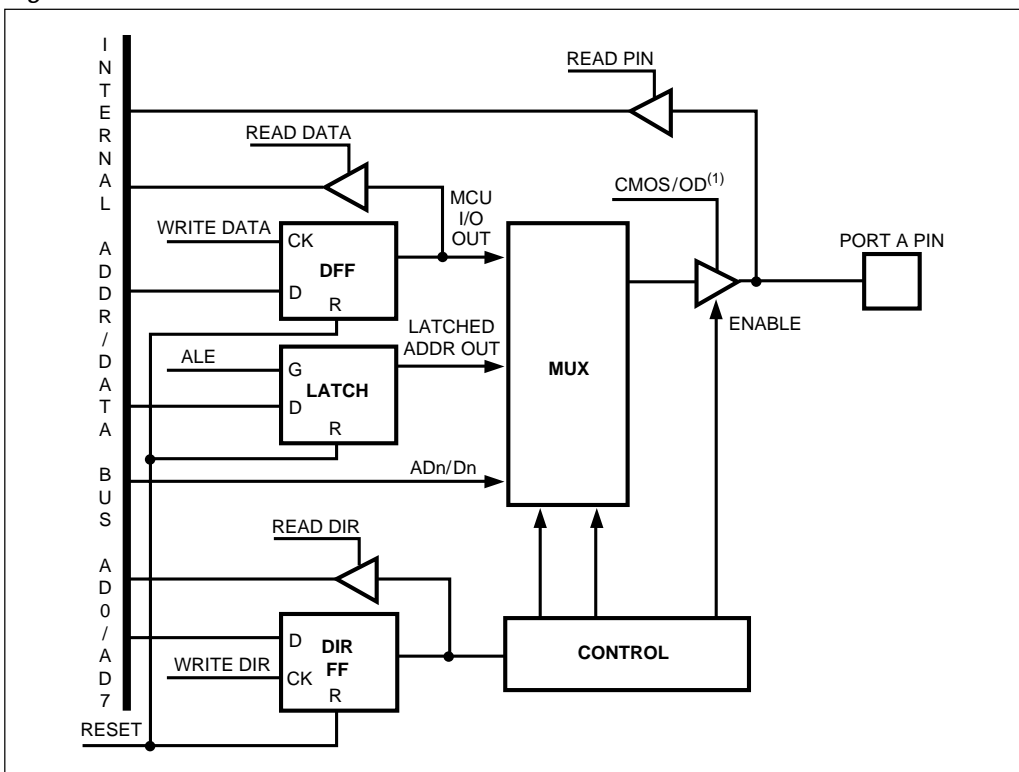
- The direction is controlled by:
  - ALE/AS
  - $\overline{RD}/E$  or  $\overline{RD}/E/\overline{DS}$  ( $\overline{DS}$  on non-3X1 devices only)
  - $\overline{WR}$  or  $R/\overline{W}$
  - PAD outputs CSADOUT1, CSADOUT2, and CSADIN defined in PSDsoft design.
- When CSADOUT1 and ALE/AS are true, the address on AD0/A0-AD7/A7 is output on Port A. Note: carefully check the generation of CSADOUT1 to ensure that it is stable during the ALE/AS pulse.
- When CSADOUT2 is active and a write operation is performed, the data on the AD0/A0-AD7/A7 input pins flows out through Port A.
- When CSADIN is active and a read operation is performed, the data on Port A flows out through the AD0/A0-AD7/A7 pins.
- Port A is tri-stated when none of the above conditions exist.

10.0  
I/O Port  
Functions  
(cont.)

10.2.2 Port A (PA0-PA7) in Non-Multiplexed Address/Data Mode

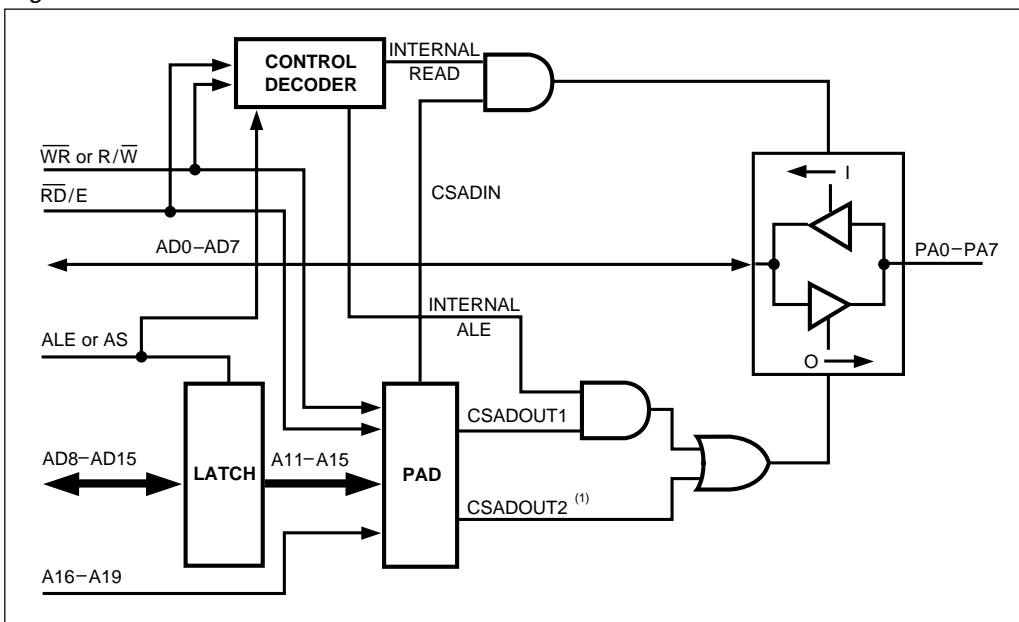
In this mode, Port A becomes the low-order data bus byte of the chip. When reading an internal location, data is presented on Port A pins to the MCU. When writing to an internal location, data present on Port A pins from the MCU is written to the desired location.

Figure 5A. Port A Pin Structure



NOTE: 1. CMOS/OD determines whether the output is open drain or CMOS.

Figure 5B. Port A Track Mode



NOTE: 1. The expression for CSADOUT2 must include the following write operation cycle signals:  
For CRRWR = 0, CSADOUT2 must include  $\overline{WR} = 0$ .  
For CRRWR = 1, CSADOUT2 must include  $E = 1$  and  $\overline{R/W} = 0$ .



## 10. I/O Port Functions (cont.)

### 10.3 Port B (PB0-PB7)

The control registers of Port B are located in CSIOPORT space; see Table 5A and 5B.

#### 10.3.1 Port B (PB0-PB7) in Multiplexed Address/Data Mode

Each pin of Port B can be individually configured. The following table summarizes what the control registers (in CSIOPORT space) for Port B do:

Register Name	0 Value	1 Value	Default Value (Note 1)
Port B Pin Register	Sampled logic level at pin = '0'	Sampled logic level at pin = '1'	X
Port B Direction Register	Pin is configured as input	Pin is configured as output	0
Port B Data Register	Data in DFF = '0'	Data in DFF = '1'	0

**NOTE:** 1. Default value is the value after reset.

#### MCU I/O Mode

The default configuration of Port B is MCU I/O. In this mode, every pin can be set (at run-time) as an input or output by writing to the respective pin's direction flip-flop (DIR FF, Figure 6). As an output, the pin level can be controlled by writing to the respective pin's data flip-flop (DFF, Figure 6). The Pin Register can be read to determine logic level of the pin. The contents of the Pin Register indicate the true state of the PSD driving the pin through the DFF or an external source driving the pin. Pins can be configured as CMOS or open-drain using ST's PSDsoft software. Open-drain pins require external pull-up resistors.

#### Chip Select Output

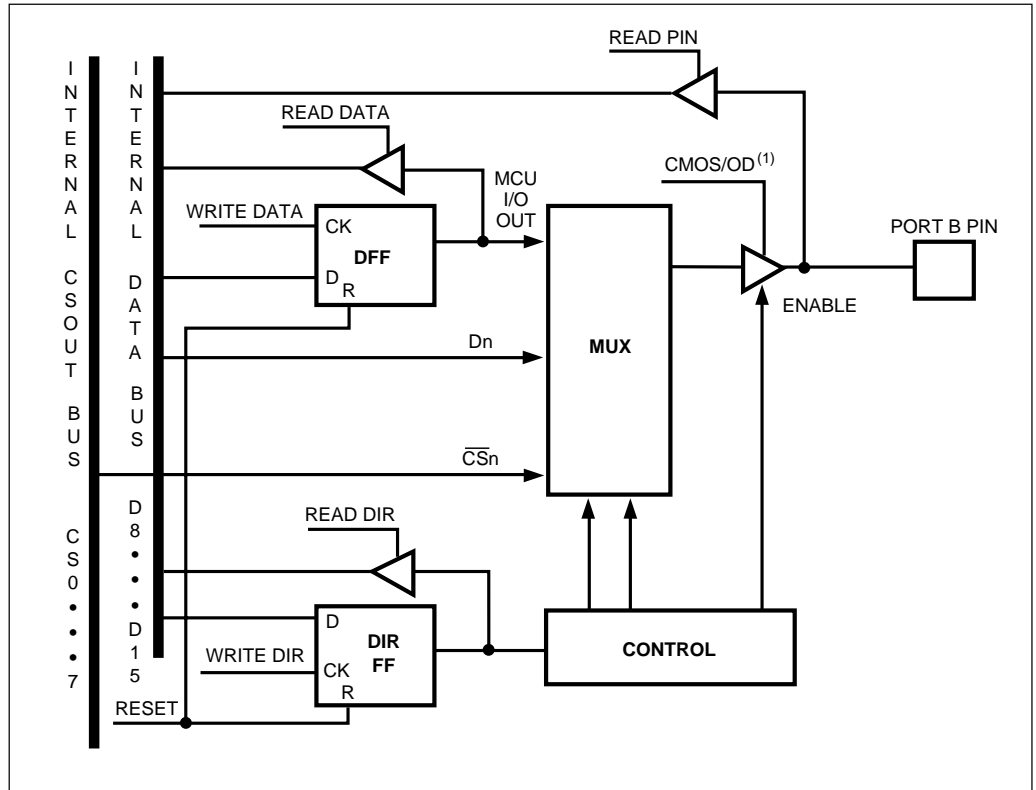
Alternatively, each bit of Port B can be configured to provide a chip-select output signal from PAD B. PB0-PB7 can provide CS0-CS7, respectively. The functionality of these pins is not limited to chip selects only; they can be used for generic combinatorial logic as well. Each of the CS0-CS3 signals is comprised of four product terms, and each of the CS4-CS7 signals is comprised of two product terms.

## 10. I/O Port Functions (cont.)

### 10.3.2 Port B (PB0-PB7) in 16-bit Multiplexed Address/Data Mode

In this mode, Port B becomes the low-order data bus byte to the MCU chip. When reading an internal high-order location, data is presented on Port B pins to the MCU. When writing to an internal high-order location, data present on Port B pins from the MCU is written to the desired location.

Figure 6. Port B Pin Structure



**NOTE:** 1. CMOS/OD determines whether the output is open drain or CMOS.

## 10. I/O Port Functions (cont.)

### 10.4 Port C (PC0-PC2)

Each pin of Port C (Figure 7) can be configured as an input to PAD A and PAD B, or as an output from PAD B. As inputs, the pins are referenced as A16-A18. Although the pins are given this reference, they can be used for **any** address **or** logic input. [For example, A8-A10 could be connected to those pins to improve the resolution (boundaries) of CS0-CS7 to 256 bytes.] How they are defined in the PSDsoft design file determines:

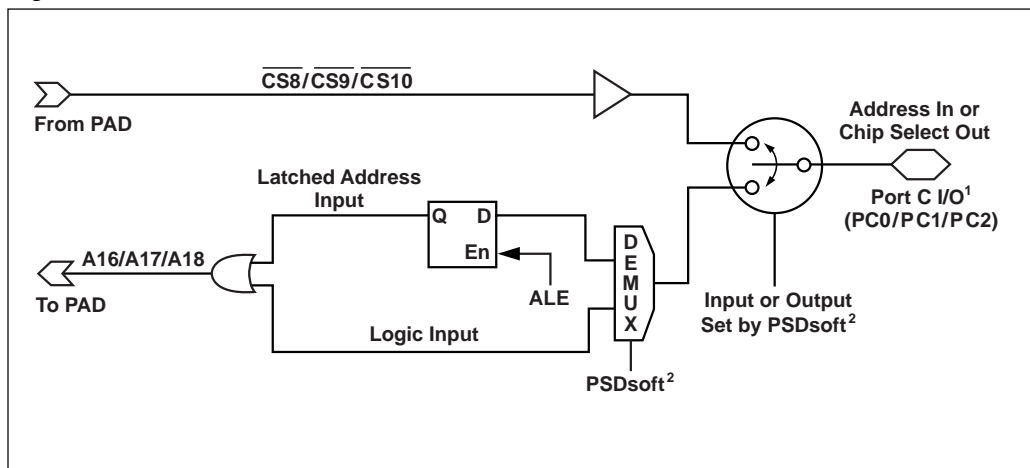
- Whether they are address or logic inputs
- Whether the input is transparent or latched by the trailing edge of ALE/AS.

#### Notes:

- 1) If the inputs are addresses, they are routed to PAD A and PAD B, and can be used in any or all PAD equations.
- 2) A logic input is routed to PAD B and can be used for Boolean equations that are implemented in any or all of the CS0-CS10 PAD B outputs.

Alternately, PC0-PC2 can become CS8-CS10 outputs, respectively, providing the user with more external chip-select PAD outputs. Each of the signals ( $\overline{CS8-CS10}$ ) is comprised of one product term.

Figure 7. Port C (PC0-PC2) Pin Structure



- NOTES:**
1. Port C pins can be individually configured as inputs **or** outputs, but **not** both. Pins can be individually configured as address or logic and latched or transparent, except for the 3X1 devices, which must be set to all address or all logic.
  2. PSDsoft sets this configuration prior to run-time based on your PSDsoft design file.

### 10.5 ALE/AS Input Pin

The ALE/AS pin may be used as a generic logic input signal to the PADs if a non-multiplexed MCU configuration is chosen in PSDsoft.

## 11. PSD Memory

The following sections explain the various memory blocks and memory options within the PSD3XX.

### 11.1 EPROM

For all of the PSD3XX devices, the EPROM is built using Zero-power technology. This means that the EPROM powers up only when the address changes. It consumes power for the necessary time to latch data on its outputs. After this, it powers down and remains in Standby Mode until the next address change. This happens automatically, and the designer has to do nothing special.

The EPROM is divided into eight equal-sized banks. Each bank can be placed in any address location by programming the PAD. Bank0-Bank7 are selected by PAD A outputs ES0-ES7, respectively. There is one product term for each bank select (ESi).

Refer to Table 1 to see the size of the EPROM for each PSD device.

### 11.2 SRAM (Optional)

Like the EPROM, the optional SRAM in the PSD3XX devices is built using Zero-power technology.

All PSD3XX parts which do not have an R suffix contain 2 Kbytes of SRAM (Table 1). The SRAM is selected by the RS0 output of the PAD. There is one product term dedicated to RS0.

If your design requires a SRAM larger than 2K x 8, then use one of the RAMless (R versions) of the 3XX devices with an external SRAM. The external SRAM can be addressed through Port A and all require logic will be taken care of by the PSD3XXR.

### 11.3 Page Register (Optional)

All PSD3XX parts, except 3X1 devices, have a four-bit page register. Thus the effective address space of your MCU can be enlarged by a factor of 16. Each bit of the Page Register can be individually read or written. The Page Register is located in CSIOPORT space (at offset 18h); see Table 5. The Page Register is connected to the lowest nibble of the data bus (D3-D0). The outputs of the Page Register, P3-P0, are connected to PAD A, and therefore can be used in any chip select (internal or external) equations. The contents of the page register are reset to zero at power-up and after any chip-level reset.

### 11.4 Programming and Erasure

Programming the device can be done using the following methods:

- ST's main programmer—PSDpro—which is accessible through a parallel port.
- ST's programmer used specifically with the PSD3XX—PEP300.
- ST's discontinued programmer—Magic Pro.
- A 3rd party programmer, such as Data I/O.

Information for programming the device is available directly from ST. Please contact your local sales representative. Also, check our web site ([www.st.com/psm](http://www.st.com/psm)) for information related to 3rd party programmers.

Upon delivery from ST or after each erasure (using windowed part), the PSD3XX device has all bits in PAD and EPROM in the HI state (logic 1). The configuration bits are in the LO state (logic 0).

To clear all locations of their programmed contents (assuming you have a windowed version), expose the windowed device to an Ultra-Violet (UV) light source. A dosage of 30 W second/cm<sup>2</sup> is required for PSD3XX devices, and 40 W second/cm<sup>2</sup> for low-voltage (V suffix) devices. This dosage can be obtained with exposure to a wavelength of 2537 Å and intensity of 12000 μW/cm<sup>2</sup> for 40 to 45 minutes for the PSD3XX and 55 to 60 minutes for the low-voltage (V suffix) devices. The device should be approximately 1 inch (2.54 cm) from the source, and all filters should be removed from the UV light source prior to erasure.

The PSD3XX devices will erase with light sources having wavelengths shorter than 4000 Å. However, the erasure times will be much longer than when using the recommended 2537 Å wavelength. Note: exposure to sunlight will eventually erase the device. If used in such an environment, the package window should be covered with an opaque substance.





## 12.0 Control Signals

Consult your MCU data sheet to determine which control signals your MCU generates, and how they operate. This section is intended to show which control signals should be connected to what pins on the PSD3XX. You will then use PSDsoft to configure the PSD3XX, based on the combination of control signals that your MCU outputs, for example  $\overline{RD}$ ,  $\overline{WR}$ , and  $\overline{PSEN}$ .

The PSD3XX is compatible with the following control signals:

- ALE or AS (polarity is programmable)
- $\overline{WR}$  or  $R/\overline{W}$
- $\overline{RD}/E$  or  $\overline{RD}/E/\overline{DS}$  ( $\overline{DS}$  for non-3X1 devices only)
- $\overline{BHE}$  or  $\overline{PSEN}$
- $A19/\overline{CS1}$
- RESET (polarity is programmable except on low voltage versions with the V suffix).

### 12.1 ALE or AS

Connect the ALE or AS signal from your MCU to this pin where applicable, and program the polarity using PSDsoft. The trailing edge (when the signal goes inactive) of ALE or AS latches the address on any pins that have an address input. If you are using a non-multiplexed-bus MCU that does not output an ALE or AS signal, this pin can be used for a generic input to the PAD. **Note: if your data is multiplexed with address lines other than A0-A7**, connect your address pins to AD0/A0-AD15/A15, and connect your data to Port A (and Port B where applicable), and connect the ALE/AS signal to this pin.

### 12.2 $\overline{WR}$ or $R/\overline{W}$

Your MCU should output a stand-alone write signal ( $\overline{WR}$ ) or a multiplexed read/write signal ( $R/\overline{W}$ ). In either case, the signal should be connected to this pin.

### 12.3 $\overline{RD}/E/\overline{DS}$ ( $\overline{DS}$ option not available on 3X1 devices)

Your MCU should output any one of  $\overline{RD}$ , E (clock), or  $\overline{DS}$ . In any case, connect the appropriate signal to this pin.

### 12.4 $\overline{BHE}$ or $\overline{PSEN}$

- If your MCU does not output either of these signals, tie this pin to Vcc (through a series resistor), and skip to the next signal.
- If you use an 8-bit 8031 compatible MCU that outputs a separate signal when accessing program space, such as  $\overline{PSEN}$ , connect it to this pin. You would then use PSDsoft to configure the EPROM in the PSD3XX to respond to  $\overline{PSEN}$  only or  $\overline{PSEN}$  and  $\overline{RD}$ . If you have an 8031 compatible MCU, refer to the "Program/Data Space and the 8031" section for further information.
- If you are using a 16-bit MCU, connect the  $\overline{BHE}$  (or similar signal) output to this pin.  $\overline{BHE}$  enables accessing of the upper byte of the data bus. See Table 6 for information on how this signal is used in conjunction with the A0 address line.

Table 6. Truth Table for  $\overline{BHE}$  and Address Bit A0 (16-bit MCUs only)

$\overline{BHE}$	A <sub>0</sub>	Operation
0	0	Whole Word
0	1	Upper Byte From/To Odd Address
1	0	Lower Byte From/To Even Address
1	1	None

## 12.0 Control Signals (cont.)

### 12.5 A19/ $\overline{\text{CSI}}$

This pin is configured using PSDsoft to be either a chip select for the entire PSD device or an additional PAD input. If your MCU can generate a chip-select signal, and you wish to save power, use the PSD chip select feature. Otherwise, use this pin as an address or logic input.

- When configured as  $\overline{\text{CSI}}$  (active-low PSD chip select): a low on this pin keeps the PSD in normal operation. However, when a high is detected on the pin, the PSD enters Power-down Mode. See Tables 7A and 7B for information on signal states during Power-down Mode. See section 16 for details about the reduction of power consumption.
- When configured as A19, the pin can be used as an additional input to the PADS. It can be used for address or logic. It can also be ALE/AS dependent or a transparent input, which is determined by your PSDsoft design file. In A19 mode, the PSD is always enabled.

Table 7A. Signal States During Power-Down Mode

Port	Configuration Mode(s)	State
AD0–A0/AD15/A15	All	Input (Hi-Z)
Port Pins PA0–PA7	MCU I/O	Unchanged
	Tracking AD0/A0–AD7/A7	Input (Hi-Z)
	Latched Address Out	Logic 1
Port Pins PB0–PB7	MCU I/O	Unchanged
	Chip Select Outputs, CS0–CS7, CMOS	Logic 1
	Chip Select Outputs, CS0–CS7, Open Drain	Hi-Z
Port Pins PC0–PC2	Address or Logic Inputs, A16–A18	Input (Hi-Z)
	Chip Select Outputs, CS8–CS10, CMOS only	Logic 1

Table 7B. Internal States During Power-down

Component	Internal Signal	Internal Signal State During Power-Down
PAD A and PAD B	CS0–CS10	Logic 1 (inactive)
	CSADIN, CSADOUT1, CSADOUT2, CSIOPORT, ES0–ES7, RS0	Logic 0 (inactive)
All registers in CSIOPORT address space, including: <ul style="list-style-type: none"> <li>✓ Direction</li> <li>✓ Data</li> <li>✓ Page</li> <li>✓ PMR (turbo bit, ZPSD only)</li> </ul>	N/A	All unchanged

NOTE: N/A = Not Applicable

## 12.0 Control Signals (cont.)

### 12.6 Reset Input

This is an asynchronous input to initialize the PSD device.

Refer to tables 8A and 8B for information on device status during and after reset.

The standard-voltage PSD3XX and ZPSD3XX (non-V) devices require a reset input that is asserted for at least 100 nsec. The PSD will be functional immediately after reset is de-asserted. For these standard-voltage devices, the polarity of the reset input signal is programmable using PSDsoft (active-high or active-low), to match the functionality of your MCU reset.

**Note:** It is not recommended to drive the reset input of the MCU and the reset input of the PSD with a simple RC circuit between power on ground. The input threshold of the MCU and the PSD devices may differ, causing the devices to enter and exit reset at different times because of slow ramping of the signal. This may result in the PSD not being operational when accessed by the MCU. It is recommended to drive both devices actively. A supervisory device or a gate with hysteresis is recommended.

For low-voltage ZPSD3XXV devices only, the reset input must be asserted for at least 500 nsec. The ZPSD3XXV will not be functional for an additional 500 nsec after reset is de-asserted (see Figure 8). These low voltage ZPSD3XXV devices must use an active-low polarity signal for reset. Unlike the standard PSDs, the reset polarity for the ZPSD3XXV is **not** programmable. If your MCU operates with an active high reset, you must invert this signal before driving the ZPSD3XXV reset input.

You must design your system to ensure that the PSD comes out of reset and the PSD is active before the MCU makes its first access to PSD memory. Depending on the characteristics and speed of your MCU, a delay between the PSD reset and the MCU reset may be needed.

Table 8A. External PSD Signal States During and Just After Reset

Port	Configured Mode of Operation		Signal State During Reset	Signal State Just After Reset (Note 1)
AD0/A0-AD15/A15	All		Input (Hi-Z)	MCU address and/or data
Port Pins PA0-PA7	MCU I/O		Input (Hi-Z)	Input (Hi-Z)
	Tracking AD0/A0-AD7/A7		Input (Hi-Z)	Active Track Mode
	Latched Address Out	PSD3XX, ZPSD3XX	Logic 0	MCU address
ZPSD3XXV		Hi-Z	MCU address	
Port Pins PB0-PB7	MCU I/O		Input (Hi-Z)	Input (Hi-Z)
	Chip Select Outputs, CS0-CS7, CMOS	PSD3XX, ZPSD3XX	Logic 1	Per CS equations
		ZPSD3XXV	Hi-Z	Per CS equations
	Chip Select Outputs, CS0-CS7, Open Drain	PSD3XX, ZPSD3XX	Hi-Z	Per CS equations
ZPSD3XXV		Hi-Z	Per CS equations	
Port Pins PC0-PC2	Address or Logic Inputs, A16-A18		Input (Hi-Z)	Input (Hi-Z)
	Chip Select Outputs, CS8-CS10, CMOS	PSD3XX, ZPSD3XX	Logic 1	Per CS equations
		ZPSD3XXV	Hi-Z	Per CS equations

**NOTE:** 1. Signal is valid immediately after reset for PSD3XX and ZPSD3XX devices. ZPSD3XXV devices need an additional 500 nsec after reset before signal is valid.

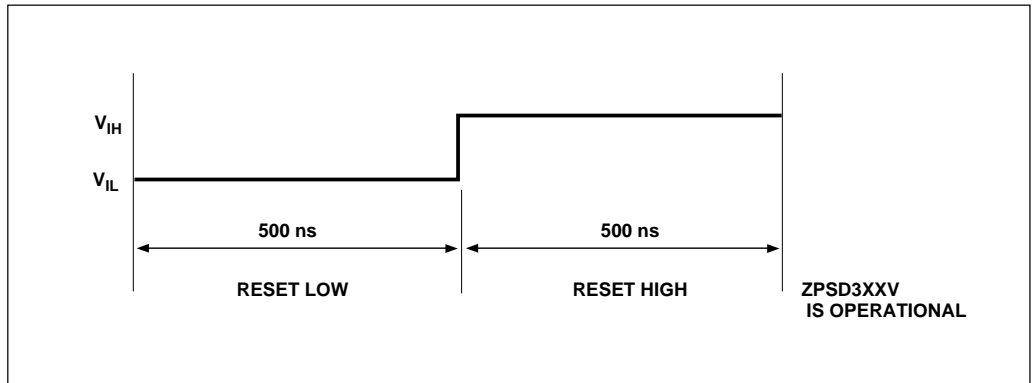
12.0  
Control Signals  
(cont.)

Table 8B. Internal PSD Signal States During and Just After Reset

Component	Internal Signal	Internal Signal State During Reset	Internal Signal State During Power-Down
PAD A and PAD B	CS0-CS10	Logic 1 (inactive)	Per CS Equations
	CSADIN, CSADOUT1, CSADOUT2, CSIOPORT, ES0-ES7, RS0	Logic 0 (inactive)	Per equations for each internal signal
All registers in CSIOPORT address space, including: ✓ Direction ✓ Data ✓ Page ✓ PMR (turbo bit, ZPSD3XX only)	N/A	Logic 0 in all bit of all registers	Logic 0 until changed by MCU

NOTE: N/A = Not Applicable

Figure 8. The Reset Cycle ( $\overline{\text{RESET}}$ ) (ZPSD3XXV Versions)



### 13.0 Program/Data Space and the 8031

This section only applies to users who have an 8031 or compatible MCU that outputs a signal such as  $\overline{\text{PSEN}}$  when accessing program space. If this applies to you, be aware of the following:

- ❑ The PSD3XX can be configured using PSDsoft such that the EPROM is either 1) accessed by  $\overline{\text{PSEN}}$  only (Figure 10); or 2) accessed by  $\overline{\text{PSEN}}$  or  $\overline{\text{RD}}$  (Figure 9). The default is  $\overline{\text{PSEN}}$  only unless changed in PSDsoft.
- ❑ The SRAM and I/O Ports (including CSIOPORT) can not be placed in program space only. By default, they are in data space only (Figure 10). However, the SRAM may be placed in Program and Data Space, as shown in Figure 9.

Figure 9. Combined Address Space

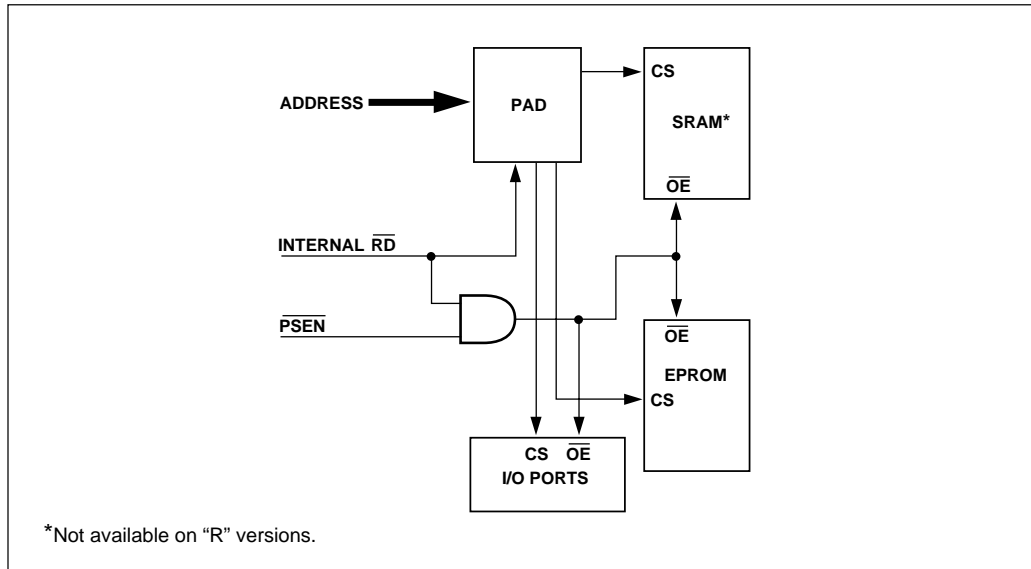
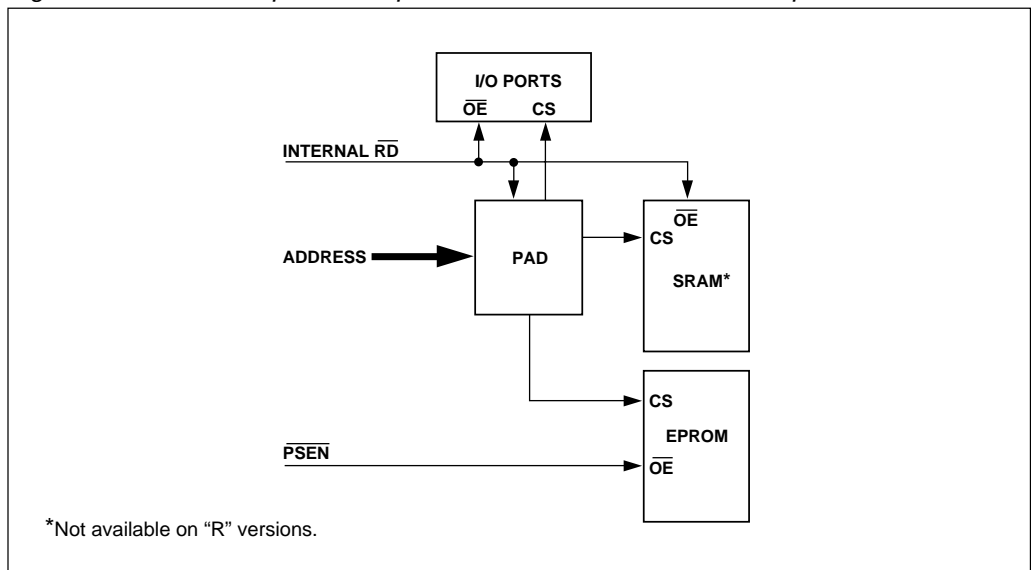


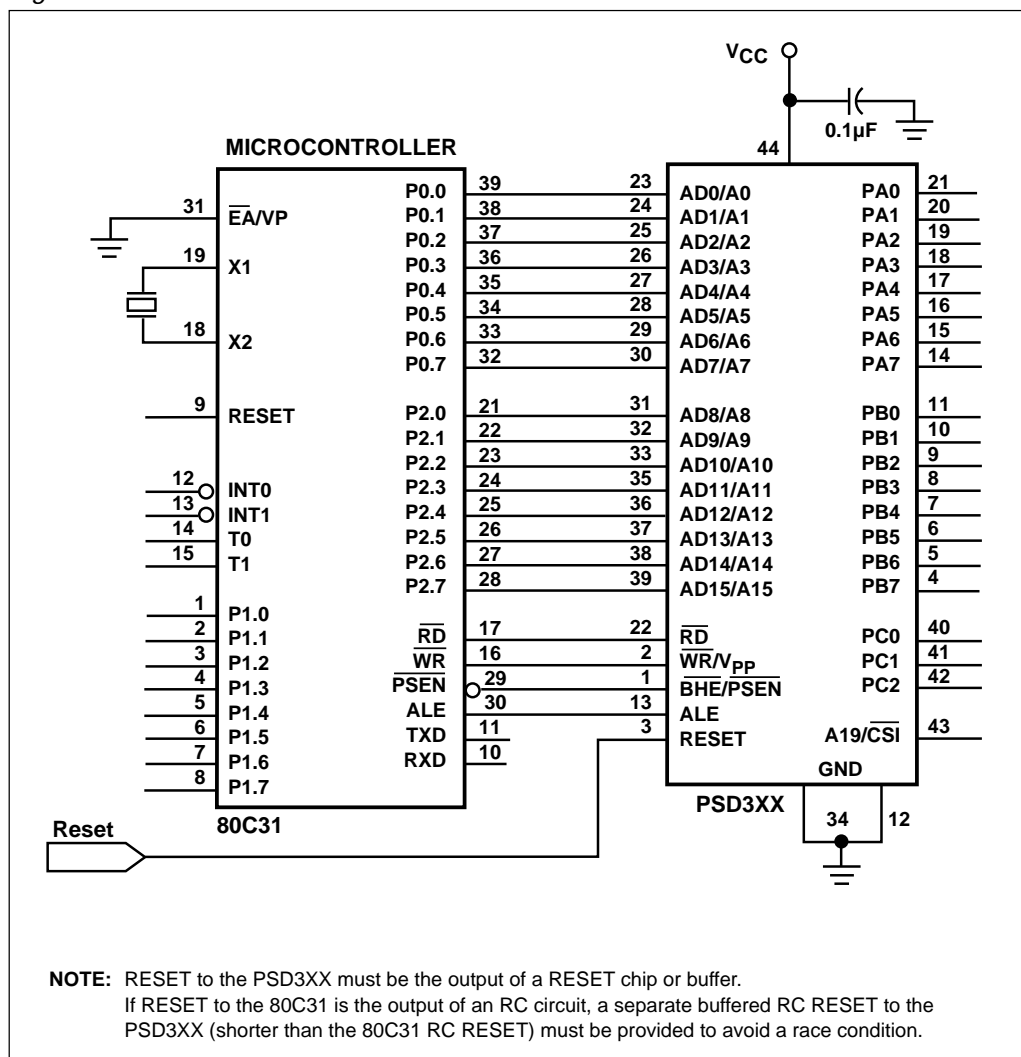
Figure 10. 8031-Compatible Separate Code and Data Address Spaces



## 14.0 System Applications

In Figure 11, the PSD3XX is configured to interface with Intel's 80C31, which is a 16-bit address/8-bit data bus microcontroller. Its data bus is multiplexed with the low-order address byte. The 80C31 uses signals  $\overline{RD}$  to read from data memory and  $\overline{PSEN}$  to read from code memory. It uses  $\overline{WR}$  to write into the data memory. It also uses active high reset and ALE signals. The rest of the configuration bits, as well as the unconnected signals, are application specific, and thus, user dependent.

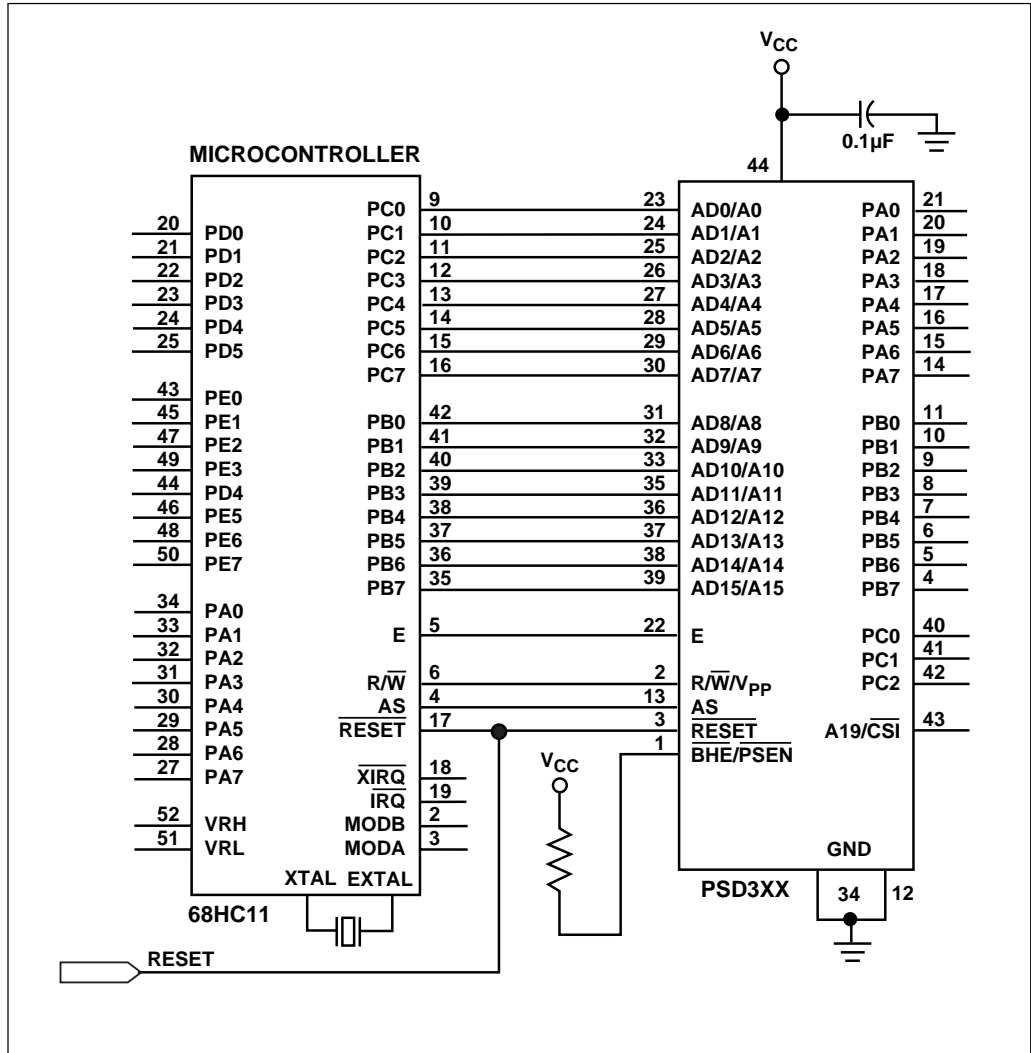
Figure 11. PSD3XX Interface With Intel's 80C31



14.0  
System  
Applications  
(cont.)

In Figure 12, the PSD3XX is configured to interface with Motorola's 68HC11, which is a 16-bit address/8-bit data bus microcontroller. Its data bus is multiplexed with the low-order address byte. The 68HC11 uses E and R/W signals to derive the read and write strobes. It uses the Address Strobe (AS) for the address latch pulse. RESET is an active-low signal. The rest of the configuration bits, as well as the unconnected signals, are specific, and thus, user dependent.

Figure 12. PSD3XX Interface With Motorola's 68HC11

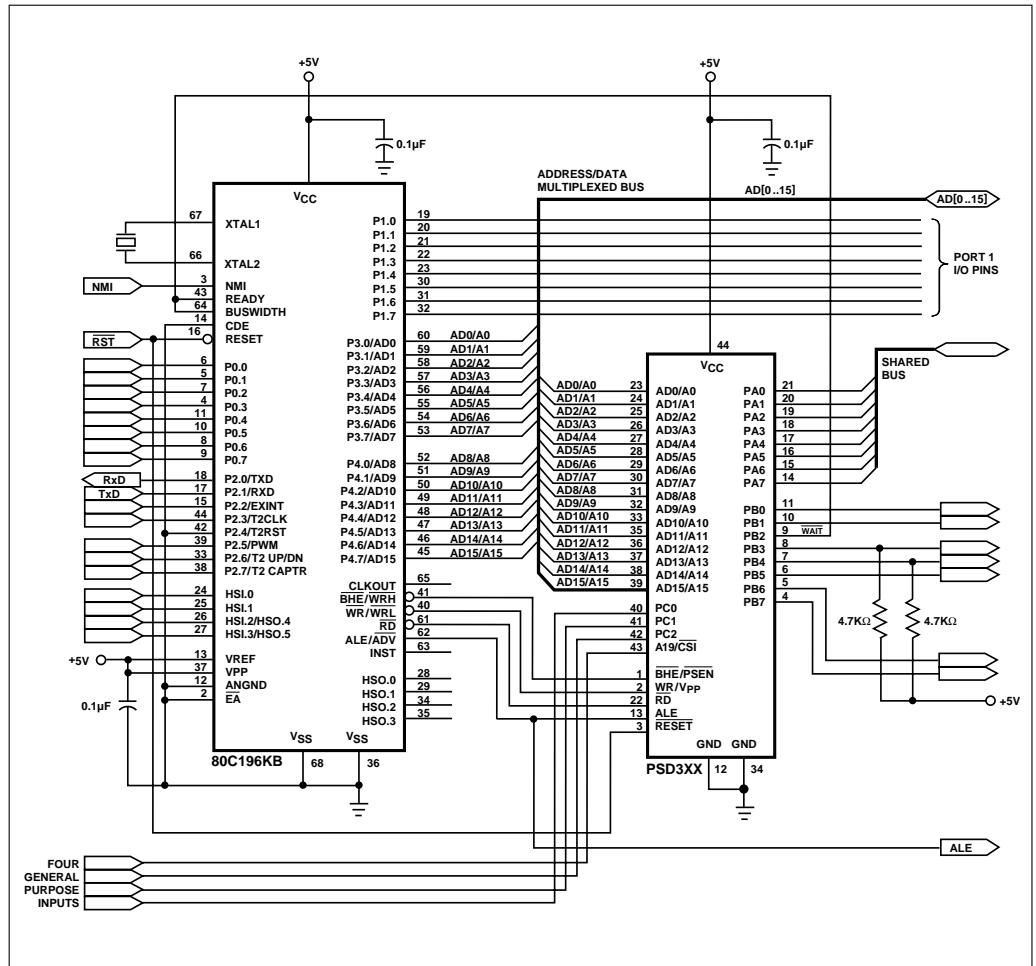


14.0  
System  
Applications  
(cont.)

In Figure 13, the PSD3XX is configured to work directly with Intel's 80C196KB microcontroller, which is a 16-bit address/16-bit data bus processor. The Address and data lines multiplexed. The PSD3XX is configured to use PC0, PC1, PC2, and A19/ $\overline{\text{CS}}1$  as logic inputs. These signals are independent of the ALE pulse (latch-transparent). They are used as four general-purpose inputs that take part in the PAD equations.

Port A is configured to work in Track Mode, in which (for certain conditions) PA0–PA7 tracks lines AD0/A0–AD7/A7. Port B is configured to generate CS0–CS7. In this example, PB2 serves as a  $\overline{\text{WAIT}}$  signal that slows down the 80C196KB during the access of external peripherals. These 8-bit wide peripherals are connected to the shared bus of Port A. The  $\overline{\text{WAIT}}$  signal also drives the buswidth input of the microcontroller, so that every external peripheral cycle becomes an 8-bit data bus cycle. PB3 and PB4 are open-drain output signals; thus, they are pulled up externally.

Figure 13. PSD3XX Interface With Intel's 80C196KB





## 15.0 Security Mode

Security Mode in the PSD3XX locks the contents of PAD A, PAD B, and all the configuration bits. The EPROM, optional SRAM, and I/O contents can be accessed only through the PAD. The Security Mode must be set by PSDsoft prior to run-time. The Security Bit can only be erased on the UV parts using a full-chip erase. If Security Mode is enabled, the contents of the PSD3XX can not be uploaded (copied) on a device programmer.

## 16.0 Power Management

PSDs from all PSD3XX families use Zero-power memory techniques that place memory into Standby Mode between MCU accesses. The memory becomes active briefly after an address transition, then delivers new data to the outputs, latches the outputs, and returns to Standby. This is done automatically and the designer has to do nothing special to benefit from this feature.

In addition to the benefits of Zero-power memory technology, there are ways to gain additional savings. The following factors determine how much current the entire PSD device uses:

- Use of  $\overline{\text{CSI}}$  (Chip Select Input)
- Setting of the CMiser bit
- Setting of the Turbo Bit (ZPSD only)
- The number of product terms used in the PAD
- The composite frequency of the input signals to the PAD
- The loading on I/O pins.

The total current consumption for the PSD is calculated by summing the currents from memory, PAD logic, and I/O pins, based on your design parameters and the power management options used.

### 16.1 $\overline{\text{CSI}}$ Input

Driving the  $\overline{\text{CSI}}$  pin inactive (logic 1) disables the inputs of the PSD and forces the entire PSD to enter Power-down Mode, independent of any transition on the MCU bus (address and control) or other PSD inputs. During this time, the PSD device draws only standby current (micro-amps). Alternately, driving a logic 0 on the  $\overline{\text{CSI}}$  pin returns the PSD to normal operation. See Tables 7A and 7B for information on signal states during Power-down Mode.

The  $\overline{\text{CSI}}$  pin feature is available only if enabled in the PSDsoft Configuration utility.

### 16.2 CMiser bit

In addition to power savings resulting from the Zero-power technology used in the memory, the CMiser feature saves even more power under certain conditions. Savings are significant when the PSD is configured for an 8-bit data path because the CMiser feature turns off half of the array when memory is being accessed (the memory is divided internally into odd and even arrays). See the DC characteristics table for current usage related to the CMiser bit.

You should keep the following in mind when using this bit:

- Setting of this bit is accomplished with PSDsoft at the design stage, prior to run-time.
- Memory access times are extended by 10 nsec for standard voltage (non-V) devices, and 20 nsec for low voltage (V) devices.
- EPROM access: although CMiser offers significant power savings in 8-bit mode (~50%), CMiser contributes no additional power savings when the PSD is configured for 16-bits.
- SRAM access: CMiser reduces power consumption of PSDs configured for either 8-bit or 16-bit operation.

## 16. Power Management (cont.)

### 16.3 Turbo Bit (ZPSD only)

The turbo bit is controlled by the MCU at run-time and is accessed through bit zero of the Power Management Register (PMR). The PMR is located in CSIOPORT space at offset 10h.

#### Power Management Register (PMR)

Bit 7	Bit 6	Bit 5	Bit 4	Bit 3	Bit 2	Bit 1	Bit 0
*	*	*	*	*	*	*	Turbo bit
1=OFF	1=OFF	1=OFF	1=OFF	1=OFF	1=OFF	1=OFF	1=OFF

\*Future Configuration bits are reserved and should be set to one when writing to this register.

The default value at reset of all bits in the PMR is logic 0, which means the Turbo feature is enabled. The PAD logic (PAD A and PAD B) of the PSD will operate at full speed and full power. When the Turbo Bit is set to logic 1, the Turbo feature is disabled. When disabled, the PAD logic will draw only standby current (micro-amps) while no PAD inputs change. Whenever there is a transition on any PAD input (including MCU address and control signals), the PAD logic will power up and will generate new outputs, latch those outputs, then go back to Standby Mode. Keep in mind that the signal propagation delay through the PAD logic increases by 10 nsec for non-V devices, and 20 nsec for V devices while in non-turbo mode. Use of the Turbo Bit does not affect the operation or power consumption of memory.

Tremendous power savings are possible by setting the Turbo Bit and going into non-turbo mode. This essentially reduces the DC power consumption of the PAD logic to zero. It also reduces the AC power consumption of PAD logic when the composite frequency of all PAD inputs change at a rate less than 40 MHz for non-V devices, and less than 20 MHz for V devices. Use Figures 14 and 15 to calculate AC and DC current usage in the PAD with the Turbo Bit on and off. You will need to know the number of product terms that are used in your design and you will have to calculate the composite frequency of all signals entering the PAD logic.

### 16.4 Number of Product Terms in the PAD Logic

The number of product terms used in your design relates directly to how much current the PADs will draw. Therefore, minimizing this number will be in your best interest if power is a concern for you. Basically, the amount of product terms your design will use is based on the following (see Figure 4):

- Each of the EPROM block selects, ES0-ES7 uses one product term (for a total of 8).
- The CSIOPORT select uses one product term.
- If your part has SRAM (non-R versions), the SRAM select RS0 uses one product term.
- The Track Mode control signals (CSADIN, CSADOUT1, and CSADOUT2) each use one product term if you use these signals.
- Port B, pins PB0-PB3 are allocated four product terms each if used as outputs.
- Port B, pins PB4-PB7 are allocated two product terms each if used as outputs.
- Port C, pins PC0-PC2 are allocated one product term each if used as outputs.

Given the above product term allocation, keep the following points in mind when calculating the total number of product terms your design will require:

- 1) The EPROM block selects, CSIOPORT select, and SRAM select will use a product term whether you use these blocks or not. This means you start out with 10 product terms, and go up from there.
- 2) For Port B, if you use a pin as an output and your logic equation requires only one product term, you still have to include all the available product terms for that pin for power consumption, even though only one product term is specified. For example, if the output equation for pin PB0 uses just one product term, you will have to count PB0 as contributing four product terms to the overall count. With this in mind, you should use Port C for the outputs that only require one product term and PB4-7 for outputs that require two product terms. Use pins PB0-3 if you need outputs requiring more than two product terms or you have run out of outputs.
- 3) The following PSD functions do not consume product terms: MCU I/O mode, Latched Address Output, and PAD inputs (logic or address).



## 16.0 Power Management (cont.)

### 16.5 Composite Frequency of the Input Signals to the PAD Logic

The composite frequency of the input signals to the PADs is calculated by considering all transitions on any PAD input signal (including the MCU address and control inputs). Once you have calculated the composite frequency and know the number of product terms used, you can determine the total AC current consumption of the PAD by using Figure 14 or Figure 15. From the figures, notice that the DC component ( $f = 0$  MHz) of PAD current is essentially zero when the turbo feature is disabled, and that the AC component increases as frequency increases.

When the turbo feature is disabled, the PAD logic can achieve low power consumption by becoming active briefly, only when inputs change. For standard voltage (non-V) devices, the PAD logic will stay active for 25 nsec after it detects a transition on any input. If there are more transitions on any PAD input within the 25 nsec period, these transitions will not add to power consumption because the PAD logic is already active. This effect helps reduce the overall composite frequency value. In other words, narrowly spaced groups of transitions on input signals may count as just one transition when estimating the composite frequency.

Note that the “knee” frequency in Figure 14 is 40 MHz, which means that the PAD will consume less power only if the composite frequency of all PAD inputs is less than 40 MHz. When the composite frequency is above 40 MHz, the PAD logic never gets a chance to shut down (inputs are spaced less than 25 nsec) and no power savings can be achieved. Figure 15 is for low-voltage devices in which the “knee” frequency is 20 MHz.

Take the following steps to calculate the composite frequency:

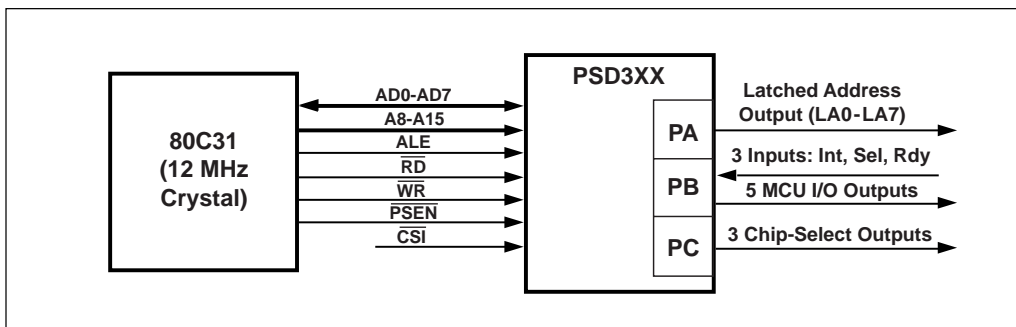
- 1) Determine your highest frequency input for either PAD A or PAD B.
- 2) Calculate the period of this input and use this period as a basis for determining the composite frequency.
- 3) Examine the remaining PAD input signals within this base period to determine the number of distinct transitions.
- 4) Signal transitions that are spaced further than 25 nsec apart count as a distinct transition (50 nsec for low-voltage V devices). Signal transitions spaced closer than 25 nsec count as the same transition.
- 5) Count up the number of distinct transitions and divide that into the value of the base period.
- 6) The result is the period of the composite frequency. Divide into one to get the composite frequency value.

Unfortunately, this procedure is complicated and usually not deterministic since different inputs may be changing in various cycles. Therefore, we recommend you think of the situation that has the most activity on the inputs to the PLD and use this to calculate the composite frequency. Then you will have a number that represents your best estimate at the worst case scenario.

Since this is a complicated process, the following example should help.

#### Example Composite Frequency Calculation

Suppose you had the following circuit:

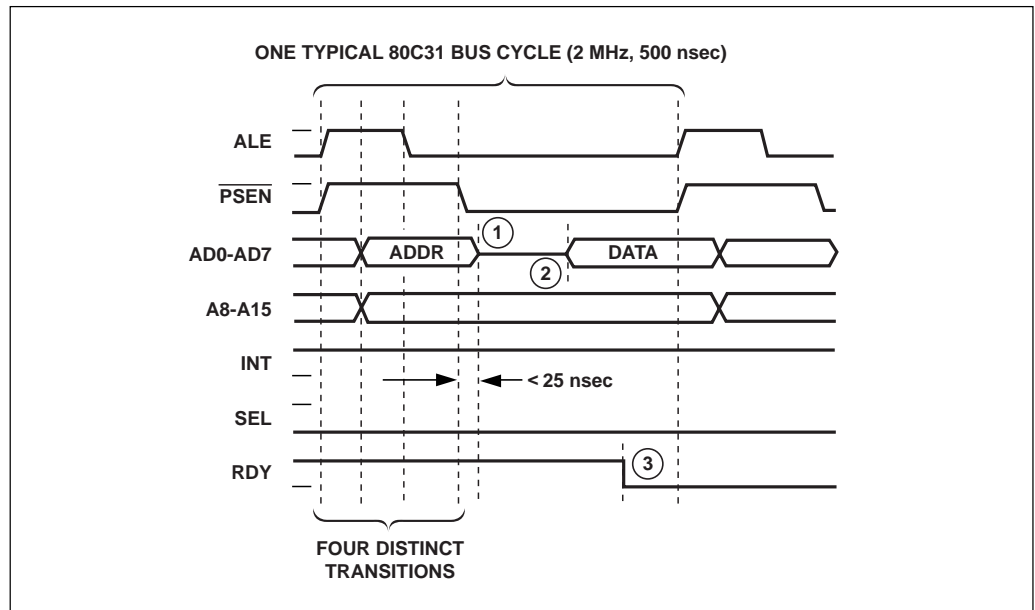


## 16.0 Power Management (cont.)

All the inputs shown, except  $\overline{CS}$ , go to the PAD logic. These signals must be taken into consideration when calculating the composite frequency. Before we make the calculation, let's establish the following conditions:

- The input with the highest frequency is ALE, which is 2 MHz. So our base period is 500 nsec for this example.
- Only the address information from the multiplexed signals AD0-AD7 reach the PAD logic because of the internal address latch. Signal transitions from data on AD0-AD7 do not reach the PADS.
- The three inputs (Int, Sel, or Rdy) change state very infrequently relative to the 80C31 bus signals.

Now, let's assume the following is a snapshot in time of all the input signals during a typical 80C31 bus cycle. We'll use a code fetch as an example since that happens most often.



The calculation of the composite frequency is as follows:

- There are four distinct transitions (first four dotted lines) within the base period of 500 nsec. These first four transitions all count toward the final composite frequency.
- The transition at (1) in the diagram does not count as a distinct transition because it is within 25 nsec of a neighboring transition (use 50 nsec for a ZPSD3XXV device).
- Transition (2) above does not add to the composite frequency because only the internally latched address signals reach the PADS, the data signal transitions do not.
- The transition at (3) just happens to appear in this snapshot, but its frequency is so low that it is not a significant contributor to the overall composite frequency, and will not be used.
- Divide the 500 nsec base period by the four (distinct transitions), yielding 125 nsec.  $1/125 \text{ nsec} = 8 \text{ MHz}$ .
- Use 8 MHz as the composite frequency of PAD inputs when calculating current consumption. (See the next section for a sample current calculation.)

### 16.6 Loading on I/O pins

A final consideration when calculating the current usage for the entire PSD device is the loading on I/O pins. All specifications for PSD current consumption in this document assume zero current flowing through PSD I/O pins (including ADIO). I/O current is dictated by the individual design implementation, and must be calculated by the designer. Be aware that I/O current is a function of loading on the pins and the frequency at which the signals toggle.



## 17. Calculating Power

Once you have read the "Power Management" section, you should be able to calculate power. The following is a sample power calculation:

<i>Conditions</i>	
Part Used	= ZPSD3XX ( $V_{CC} = 5.0\text{ V}$ )
MCU ALE Clock Frequency	= 2.0 MHz
Composite ZPLD Input Frequency	= 8.0 MHz (see example in above section)
% EPROM Access	= 80%
% SRAM Access	= 15%
% I/O access	= 5%
%Time CSI is high (standby mode)	= 90%
%Time CSI is low (normal operation mode)	= 10%
# Product terms used (see previous section)	= 13 ( $13/40 = 33\%$ )
Turbo bit	= OFF (Turbo Mode disabled)
CMiser bit	= ON
MCU Bus Configuration	= 8-bit multiplexed bus mode
<i>Calculation (Based on Typical AC and DC Currents)</i>	
$I_{CC\text{ total}} = I_{\text{standby}} \times \% \text{ time CSI is high} + [I_{CC}(\text{AC}) + I_{CC}(\text{DC})] \times \% \text{ time CSI is low.}$ $= I_{\text{standby}} \times \% \text{ time CSI is high} +$ $\quad [ \% \text{ EPROM Access} \times 0.8 \text{ mA/MHz} \times \text{Freq. of ALE}$ $\quad + \% \text{ SRAM} \times 1.4 \text{ mA/MHz} \times \text{Freq of ALE}$ $\quad + \text{ZPLD AC current (Figure 14: 13 PTs, 8 MHz, Non-Turbo)}]$ $\quad \times \% \text{ time CSI is low}$ $= 10 \mu\text{A} \times 0.9 + (0.8 \times 0.8 \text{ mA/MHz} \times 2 \text{ MHz} + 0.15 \times 1.4 \text{ mA/MHz} \times 2 \text{ MHz}$ $\quad + 5.0 \text{ mA}) \times 0.1$ $= 9.0 \mu\text{A} + (1.28 \text{ mA} + 0.42 \text{ mA} + 5.0 \text{ mA}) \times 0.1$ $= 679 \mu\text{A, based on the system operating in standby 90\% of the time}$	

- NOTES:**
1. Calculation is based on the assumption that  $I_{OUT} = 0\text{ mA}$  (no I/O pin loading)
  2.  $I_{CC}(\text{DC})$  is zero for all ZPSD devices operating in non-turbo mode.
  3. 13 product terms: 8 for EPROM, 3 for Chip Selects, 1 for SRAM, 1 for CSIOPORT.
  4. The 5% I/O access in the conditions section is when the MCU accesses CSIOPORT space.
  5. Standby Mode can also be achieved without using the CSI pin. The ZPSD device will automatically go into Standby while no inputs are changing on any pin, and Turbo Mode is disabled.

17.0  
Calculating  
Power  
(cont.)

Figure 14. Typical  $I_{CC}$  vs. Frequency for the PAD ( $V_{CC} = 5\text{ V}$ )

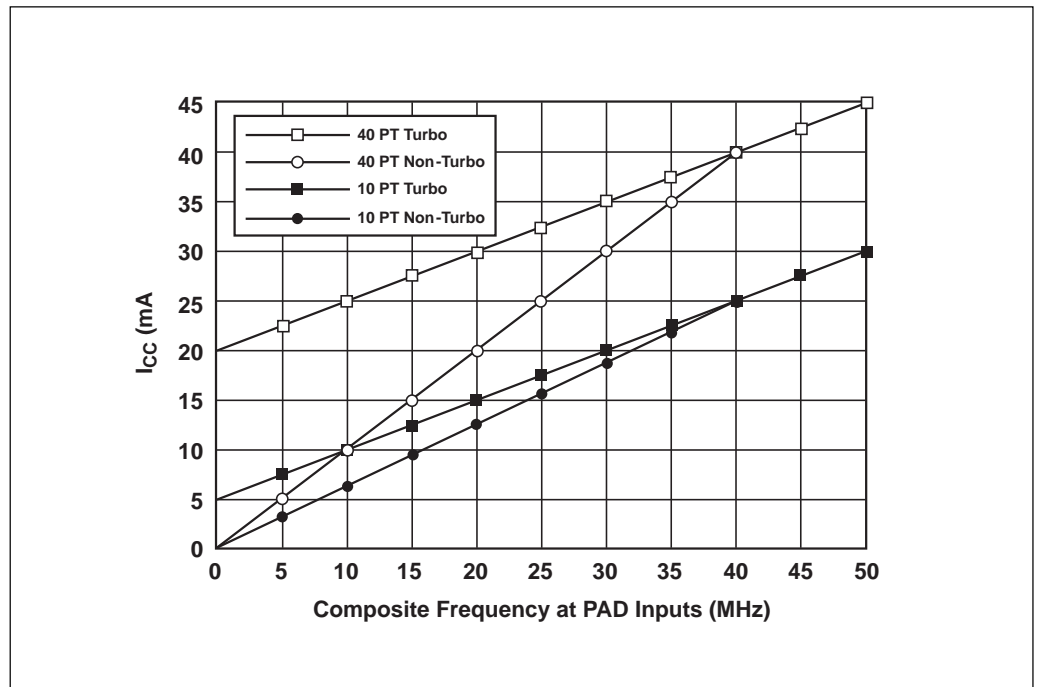


Figure 15. Typical  $I_{CC}$  vs. Frequency ( $V_{CC} = 3\text{ V}$ )

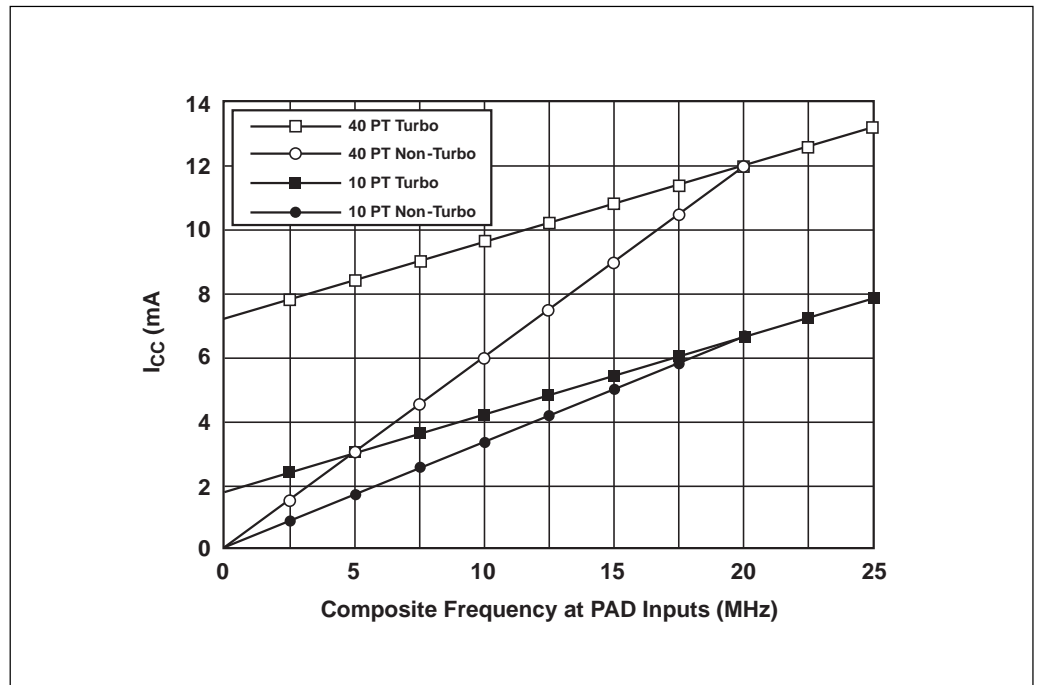


Figure 16.  $I_{OL}$  vs.  $V_{OL}$  ( $5\text{ V} \pm 10\%$ )

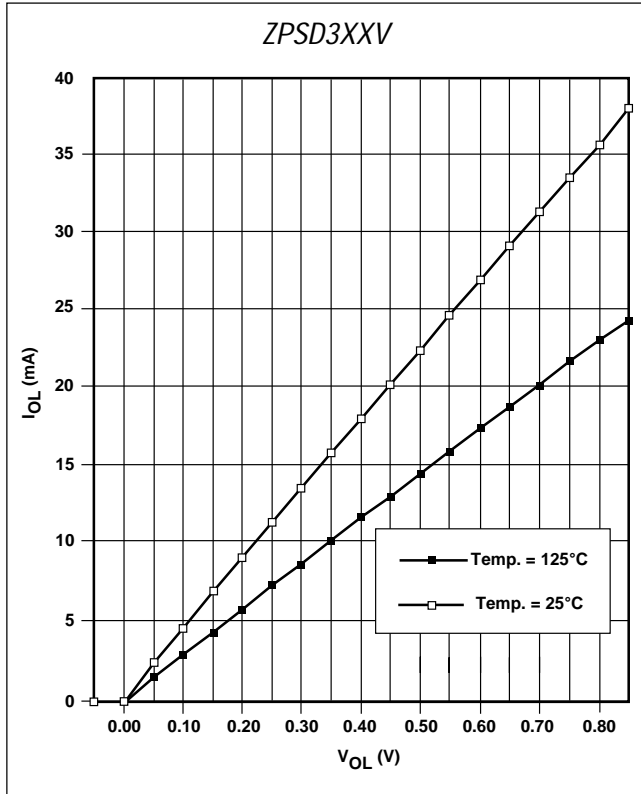


Figure 17. Normalized  $I_{CC}$  (DC vs.  $V_{CC}$ ) ( $V_{CC} = 3.0\text{ V}$ )

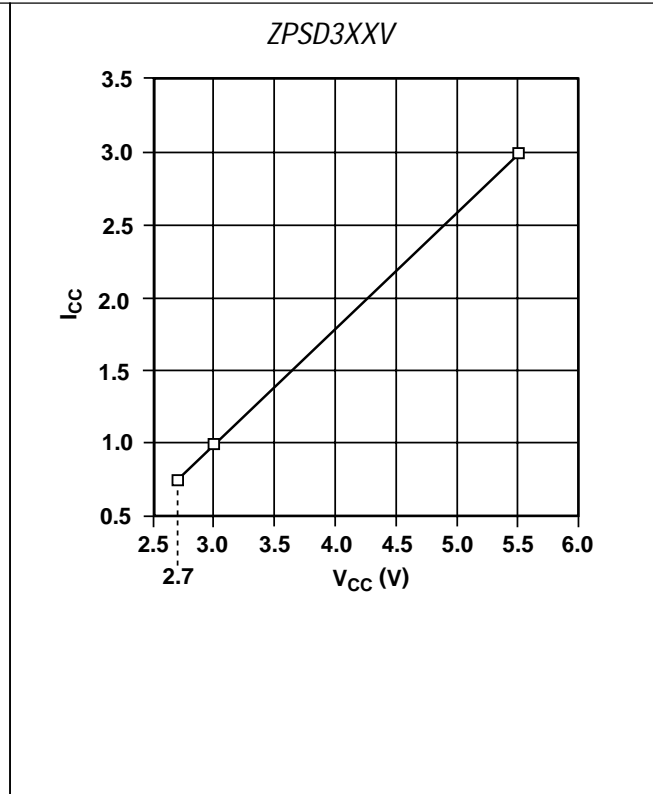


Figure 18. Normalized  $I_{CC}$  (AC) ( $V_{CC} = 3.0\text{ V}$ )

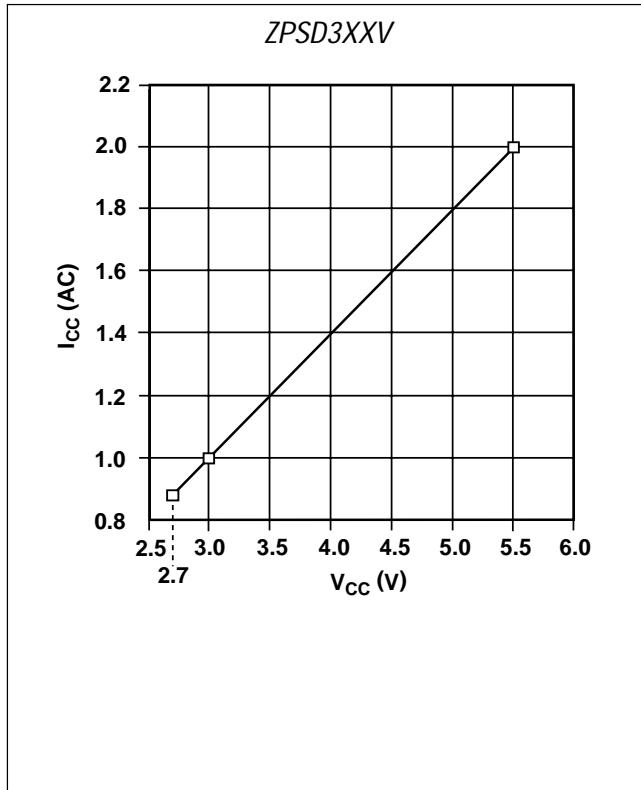
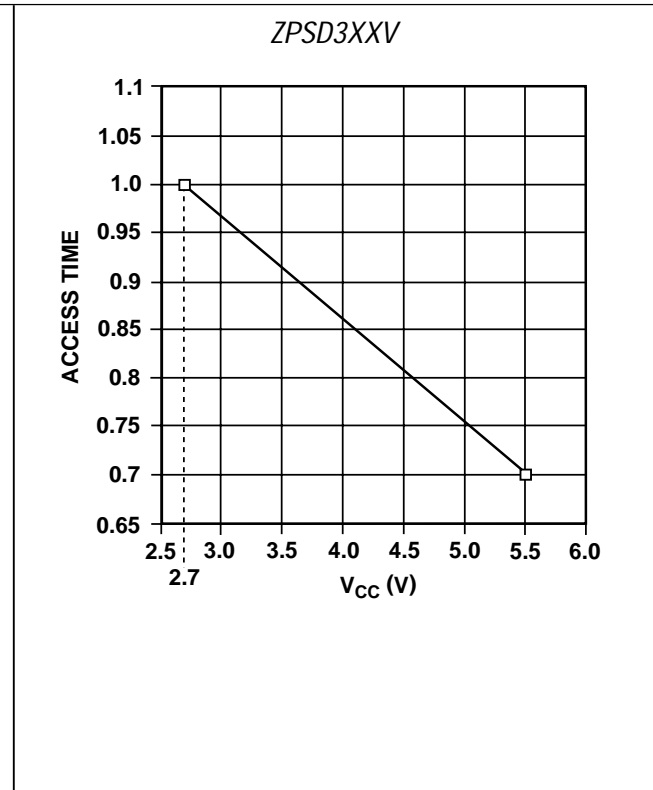


Figure 19. Normalized Access Time ( $T_6$ ) ( $V_{CC} = 3.0\text{ V}$ )



## 18.0 Specifications

### 18.1 Absolute Maximum Ratings<sup>1</sup>

Symbol	Parameter	Condition	Min	Max	Unit
T <sub>STG</sub>	Storage Temperature	CERDIP	- 65	+ 150	°C
		PLASTIC	- 65	+ 125	°C
	Voltage on any Pin	With Respect to GND	- 0.6	+ 7	V
V <sub>PP</sub>	Programming Supply Voltage	With Respect to GND	- 0.6	+ 14	V
V <sub>CC</sub>	Supply Voltage	With Respect to GND	- 0.6	+ 7	V
	ESD Protection		>2000		V

**NOTE:** 1. Stresses above those listed under Absolute Maximum Ratings may cause permanent damage to the device. This is a stress rating only and functional operation of the device at these or any other conditions above those indicated in the operational sections of this specification is not implied. Exposure to Absolute Maximum Rating conditions for extended periods of time may affect device reliability.

### 18.2 Operating Range

Range	Temperature	V <sub>CC</sub>	V <sub>CC</sub> Tolerance
Commercial	0° C to +70°C	+ 3 V <sup>1</sup> , + 5 V	± 10%
Industrial	-40° C to +85°C	+ 3 V <sup>1</sup> , + 5 V	± 10%

**NOTES:** 1. 3 V version available for ZPSD3XXV devices only.

### 18.3 Recommended Operating Conditions

Symbol	Parameter	Conditions	Min	Typ	Max	Unit
V <sub>CC</sub>	Supply Voltage	ZPSD Versions, All Speeds	4.5	5	5.5	V
V <sub>CC</sub>	Supply Voltage	ZPSD V Versions Only, All Speeds	2.7	3.0	5.5	V

### 18.4 Pin Capacitance<sup>1</sup>

Symbol	Parameter	Conditions	Typical <sup>2</sup>	Max	Unit
C <sub>IN</sub>	Capacitance (for input pins only)	V <sub>IN</sub> = 0 V	4	6	pF
C <sub>OUT</sub>	Capacitance (for input/output pins)	V <sub>OUT</sub> = 0 V	8	12	pF
C <sub>VPP</sub>	Capacitance (for $\overline{WR}/V_{PP}$ or $R/\overline{W}/V_{PP}$ )	V <sub>PP</sub> = 0 V	18	25	pF

**NOTES:** 1. This parameter is only sampled and is not 100% tested.  
2. Typical values are for T<sub>A</sub> = 25°C and nominal supply voltages.



## 18.5 AC/DC Characteristics – PSD3XX/ZPSD3XX (All 5 V devices)

Symbol	Parameter	Conditions	Min	Typ	Max	Unit
V <sub>CC</sub>	Supply Voltage	All Speeds	4.5	5	5.5	V
V <sub>IH</sub>	High-Level Input Voltage	4.5 V < V <sub>CC</sub> > 5.5 V	2		V <sub>CC</sub> + .1	V
V <sub>IL</sub>	Low-Level Input Voltage	4.5 V < V <sub>CC</sub> > 5.5 V	-0.5		0.8	V
V <sub>OH</sub>	Output High Voltage	I <sub>OH</sub> = -20 μA, V <sub>CC</sub> = 4.5 V	4.4	4.49		V
		I <sub>OH</sub> = -2 mA, V <sub>CC</sub> = 4.5 V	2.4	3.9		V
V <sub>OL</sub>	Output Low Voltage (See Figure 16)	I <sub>OL</sub> = 20 μA, V <sub>CC</sub> = 4.5 V		0.01	0.1	V
		I <sub>OL</sub> = 8 mA, V <sub>CC</sub> = 4.5 V		0.15	0.45	V
I <sub>SB</sub> (Notes 1,4)	ZPSD3XX Standby Supply Current			10	20	μA
	PSD3XX Standby Supply Current			50	100	μA
I <sub>LI</sub>	Input Leakage Current	V <sub>SS</sub> < V <sub>IN</sub> > V <sub>CC</sub>	-1	±.1	1	μA
I <sub>LO</sub>	Output Leakage Current	.45 < V <sub>IN</sub> > V <sub>CC</sub>	-10	± 5	10	μA
I <sub>CC</sub> (DC) (Note 3)	ZPSD3XX Operating Supply Current	ZPLD Turbo Mode = Off, f = 0 MHz	See I <sub>SB</sub>			μA
		ZPLD Turbo Mode = On, f = 0 MHz		0.5	1	mA/PT
		EPROM, f = 0 MHz		0	0	μA
		SRAM, f = 0 MHz		0	0	μA
	PSD3XX Operating Supply Current	PLD, f = 0 MHz		0.5	1	mA/PT
		EPROM, f = 0 MHz		0	0	μA
SRAM, f = 0 MHz			0	0	μA	
I <sub>CC</sub> (AC) (Note 3)	ZPLD AC Base			See Fig. 14	1.0	mA/MHz
	EPROM Access AC Adder	CMiser = On and 8-Bit Bus Mode		0.8	2.0	mA/MHz
		All Other Cases (Note 5)		1.8	4.0	mA/MHz
	SRAM Access AC Adder	CMiser = On and 8-Bit Bus Mode		1.4	2.7	mA/MHz
		CMiser = On and 16-Bit Bus Mode		2	4	mA/MHz
CMiser = Off			3.8	7.5	mA/MHz	

- NOTES:**
1. CMOS inputs: GND ± 0.3 V or V<sub>CC</sub> ± 0.3V.
  2. TTL inputs: V<sub>IL</sub> ≤ 0.8 V, V<sub>IH</sub> ≥ 2.0 V.
  3. I<sub>OUT</sub> = 0 mA.
  4.  $\overline{\text{CSI/A19}}$  is high and the part is in a power-down configuration mode.
  5. All other cases include CMiser = On and 16-bit bus mode and CMiser = Off and 8- or 16-bit bus mode.

## 18.6 AC/DC DC Characteristics – ZPSD3XXV (3 V devices only)

Symbol	Parameter	Conditions	Min	Typ	Max	Unit
$V_{CC}$	Supply Voltage	All Speeds	2.7	3	5.5	V
$V_{IH}$	High-Level Input Voltage	$2.7\text{ V} < V_{CC} > 5.5\text{ V}$	$.7 V_{CC}$		$V_{CC} + .5$	V
$V_{IL}$	Low-Level Input Voltage	$2.7\text{ V} < V_{CC} > 5.5\text{ V}$	-0.5		$.3 V_{CC}$	V
$V_{OH}$	Output High Voltage	$I_{OH} = -20\ \mu\text{A}, V_{CC} = 2.7\text{ V}$	2.6	2.69		V
		$I_{OH} = -1\ \text{mA}, V_{CC} = 2.7\text{ V}$	2.3	2.4		V
$V_{OL}$	Output Low Voltage	$I_{OL} = 20\ \mu\text{A}, V_{CC} = 2.7\text{ V}$		0.01	0.1	V
		$I_{OL} = 4\ \text{mA}, V_{CC} = 2.7\text{ V}$		0.15	0.45	V
$I_{SB}$ (Notes 1,4)	Standby Supply Current	$V_{CC} = 3.0\text{ V}$		1	5	$\mu\text{A}$
$I_{LI}$	Input Leakage Current	$V_{IN} = V_{CC}$ or GND	-1	$\pm 1$	1	$\mu\text{A}$
$I_{LO}$	Output Leakage Current	$V_{OUT} = V_{CC}$ or GND	-1	.1	1	$\mu\text{A}$
$I_{CC}$ (DC) (Note 3)	Operating Supply Current	ZPLD Turbo Mode = Off, $f = 0\text{ MHz}, V_{CC} = 3.0\text{ V}$	See $I_{SB}$			$\mu\text{A}$
		ZPLD Turbo Mode = On, $f = 0\text{ MHz}, V_{CC} = 3.0\text{ V}$		0.17	0.35	$\text{mA/PT}$
		EPROM, $f = 0\text{ MHz},$ $V_{CC} = 3.0\text{ V}$		0	0	$\mu\text{A}$
$I_{CC}$ (AC) (Note 3)	ZPLD AC Base	See Figure 15 ( $V_{CC} = 3.0\text{ V}$ )		See Fig. 15	0.5	$\text{mZ/MHz}$
	EPROM Access AC Adder	CMiser = On and 8-Bit Bus Mode ( $V_{CC} = 3.0\text{ V}$ )		0.4	1	$\text{mA/MHz}$
		All Other Cases (Note 5) ( $V_{CC} = 3.0\text{ V}$ )		0.9	1.7	$\text{mA/MHz}$
	SRAM Access AC Adder	CMiser = On and 8-Bit Bus Mode ( $V_{CC} = 3.0\text{ V}$ )		0.7	1.4	$\text{mA/MHz}$
		CMiser = On and 16-Bit Bus Mode ( $V_{CC} = 3.0\text{ V}$ )		1	2	$\text{mA/MHz}$
		CMiser = Off ( $V_{CC} = 3.0\text{ V}$ )		1.9	3.8	$\text{mA/MHz}$

- NOTES:**
1. CMOS inputs:  $GND \pm 0.3\text{ V}$  or  $V_{CC} \pm 0.3\text{V}$ .
  2. TTL inputs:  $V_{IL} \leq 0.8\text{ V}, V_{IH} \geq 2.0\text{ V}$ .
  3.  $I_{OUT} = 0\text{ mA}$ .
  4. CSI/A19 is high and the part is in a power-down configuration mode.
  5. All other cases include CMiser = On and 16-bit bus mode and CMiser = Off and 8- or 16-bit bus mode.

## 18.7 Timing Parameters – PSD3XX/ZPSD3XX (All 5 V devices)

Symbol	Parameter	-70		-90*		-15		CMiser On = Add	Turbo Off = Add	Unit
		Min	Max	Min	Max	Min	Max			
T1	ALE or AS Pulse Width	18		20		40		0	0	ns
T2	Address Set-up Time	5		5		12		0	0	ns
T3	Address Hold Time	7		8		10		0	0	ns
T4	Leading Edge of Read to Data Active	0		0		0		0	0	ns
T5	ALE Valid to Data Valid		80		100		160	10	0	ns
T6	Address Valid to Data Valid		70		90		150	10	0	ns
T7	$\overline{\text{CS}}_1$ Active to Data Valid		80		100		160	10	0	ns
T8	Leading Edge of Read to Data Valid		20		32		55	0	0	ns
T8A	Leading Edge of Read to Data Valid in 8031-Based Architecture Operating with $\overline{\text{PSEN}}$ and $\overline{\text{RD}}$ in Separate Mode		32		32		55	0	0	ns
T9	Read Data Hold Time	0		0		0		0	0	ns
T10	Trailing Edge of Read to Data High-Z		20		32		35	0	0	ns
T11	Trailing Edge of ALE or AS to Leading Edge of Write	0		0		0		0	0	ns
T12	$\overline{\text{RD}}$ , E, $\overline{\text{PSEN}}$ , or $\overline{\text{DS}}$ Pulse Width	35		40		60		0	0	ns
T12A	$\overline{\text{WR}}$ Pulse Width	18		20		35		0	0	ns
T13	Trailing Edge of Write or Read to Leading Edge of ALE or AS	5		5		5		0	0	ns
T14	Address Valid to Trailing Edge of Write	70		90		150		0	0	ns
T15	$\overline{\text{CS}}_1$ Active to Trailing Edge of Write	80		100		160		0	0	ns
T16	Write Data Set-up Time	18		20		30		0	0	ns
T17	Write Data Hold Time	5		5		10		0	0	ns
T18	Port to Data Out Valid Propagation Delay		25		30		35	0	0	ns
T19	Port Input Hold Time	0		0		0		0	0	ns
T20	Trailing Edge of Write to Port Output Valid		30		40		50	0	0	ns
T21	ADi <sup>1</sup> or Control to $\overline{\text{CS}}_i^2$ Valid	6	20	6	25	6	35	0	10	ns
T22	ADi <sup>1</sup> or Control to $\overline{\text{CS}}_i^2$ Invalid	5	20	5	25	4	35	0	10	ns

\*-90 speed available only on Industrial Temperature versions.

## 18.7 Timing Parameters – PSD3XX/ZPSD3XX (All 5 V devices) (cont.)

Symbol	Parameter	-70		-90*		-15		CMiser On = Add	Turbo Off = Add	Unit
		Min	Max	Min	Max	Min	Max			
T23	Track Mode Address Propagation Delay: CSADOUT1 Already True		22		22		28	0	0	ns
	Latched Address Outputs, Port A		22		22		28	0	0	
T23A	Track Mode Address Propagation Delay: CSADOUT1 Becomes True During ALE or AS		33		33		50	0	10	ns
T24	Track Mode Trailing Edge of ALE or AS to Address High-Z		30		32		35	0	0	ns
T25	Track Mode Read Propagation Delay		27		29		35	0	0	ns
T26	Track Mode Read Hold Time	5	29	11	29	11	29	0	0	ns
T27	Track Mode Write Cycle, Data Propagation Delay		18		20		30	0	0	ns
T28	Track Mode Write Cycle, Write to Data Propagation Delay	6	30	8	30	9	40	0	10	ns
T29	Hold Time of Port A Valid During Write $\overline{CSO}_i^2$ Trailing Edge	2		2		2		0	0	ns
T30	$\overline{CSI}$ Active to $\overline{CSO}_i^2$ Active	8	37	9	40	9	50	0	0	ns
T31	$\overline{CSI}$ Inactive to $\overline{CSO}_i^2$ Inactive	8	37	9	40	9	50	0	0	ns
T32	Direct PAD Input <sup>3</sup> as Hold Time	0		10		12		0	0	ns
T33	R/W Active to E or $\overline{DS}$ Start	18		20		30		0	0	ns
T34	E or $\overline{DS}$ End to R/W	18		20		30		0	0	ns
T35	AS Inactive to E high	0		0		0		0	0	ns
T36	Address to Leading Edge of Write	18		20		25		0	0	ns

- NOTES:**
1. ADi = any address line.
  2.  $\overline{CSO}_i$  = any of the chip-select output signals coming through Port B ( $\overline{CS0}$ – $\overline{CS7}$ ) or through Port C ( $\overline{CS8}$ – $\overline{CS10}$ ).
  3. Direct PAD input = any of the following direct PAD input lines:  $\overline{CSI}/A19$  as transparent A19,  $\overline{RD}/E/\overline{DS}$ ,  $\overline{WR}$  or  $R/\overline{W}$ , transparent PC0–PC2, ALE (or AS).
  4. Control signals  $\overline{RD}/E/\overline{DS}$  or  $\overline{WR}$  or  $R/\overline{W}$ .

\*-90 speed available only on Industrial Temperature versions.



## 18.8 Timing Parameters – ZPSD3XXV (3 V devices only)

Symbol	Parameter	-15*		-20		-25		CMiser On = Add	Turbo Off = Add	Unit
		Min	Max	Min	Max	Min	Max			
T1	ALE or AS Pulse Width	40		50		60		0	0	ns
T2	Address Set-up Time	12		15		20		0	0	ns
T3	Address Hold Time	10		15		20		0	0	ns
T4	Leading Edge of Read to Data Active	0		0		0		0	0	ns
T5	ALE Valid to Data Valid		170		200		250	20	0	ns
T6	Address Valid to Data Valid		150		200		250	20	0	ns
T7	$\overline{\text{CS}}_1$ Active to Data Valid		160		200		250	20	0	ns
T8	Leading Edge of Read to Data Valid		45		50		60	0	0	ns
T8A	Leading Edge of Read to Data Valid in 8031-Based Architecture Operating with $\overline{\text{PSEN}}$ and $\overline{\text{RD}}$ in Separate Mode		65		70		80	0	0	ns
T9	Read Data Hold Time	0		0		0		0	0	ns
T10	Trailing Edge of Read to Data High-Z		45		50		55	0	0	ns
T11	Trailing Edge of ALE or AS to Leading Edge of Write	0		0		0		0	0	ns
T12	$\overline{\text{RD}}$ , E, $\overline{\text{PSEN}}$ , or $\overline{\text{DS}}$ Pulse Width	60		75		85		0	0	ns
T12A	$\overline{\text{WR}}$ Pulse Width	35		45		55		0	0	ns
T13	Trailing Edge of Write or Read to Leading Edge of ALE or AS	5		5		5		0	0	ns
T14	Address Valid to Trailing Edge of Write	150		200		250		0	0	ns
T15	$\overline{\text{CS}}_1$ Active to Trailing Edge of Write	160		200		250		0	0	ns
T16	Write Data Set-up Time	30		40		50		0	0	ns
T17	Write Data Hold Time	10		12		15		0	0	ns
T18	Port to Data Out Valid Propagation Delay		45		50		60	0	0	ns
T19	Port Input Hold Time	0		0		0		0	0	ns
T20	Trailing Edge of Write to Port Output Valid		50		60		70	0	0	ns
T21	AD <sub>i</sub> <sup>1</sup> or Control to $\overline{\text{CSO}}_i^2$ Valid	6	50	5	55	5	60	0	20	ns
T22	AD <sub>i</sub> <sup>1</sup> or Control to $\overline{\text{CSO}}_i^2$ Invalid	4	50	4	55	4	60	0	20	ns

\* -15 speed available only on ZPSD311V.

## 18.8 Timing Parameters – ZPSD3XXV (3 V devices only) (cont.)

Symbol	Parameter	-15*		-20		-25		CMiser On = Add	Turbo Off = Add	Unit
		Min	Max	Min	Max	Min	Max			
T23	Track Mode Address Propagation Delay: CSADOUT1 Already True		50		60		60	0	0	ns
	Latched Address Outputs, Port A		50		60		60	0	0	
T23A	Track Mode Address Propagation Delay: CSADOUT1 Becomes True During ALE or AS		70		80		90	0	20	ns
T24	Track Mode Trailing Edge of ALE or AS to Address High-Z		50		60		60	0	0	ns
T25	Track Mode Read Propagation Delay		45		55		60	0	0	ns
T26	Track Mode Read Hold Time	10	70	10	70	10	70	0	0	ns
T27	Track Mode Write Cycle, Data Propagation Delay		45		55		60	0	0	ns
T28	Track Mode Write Cycle, Write to Data Propagation Delay	8	65	8	75	8	80	0	20	ns
T29	Hold Time of Port A Valid During Write $\overline{CSO}_i^2$ Trailing Edge	2		3		3		0	0	ns
T30	$\overline{CSI}$ Active to $\overline{CSO}_i^2$ Active	9	70	9	80	9	90	0	0	ns
T31	$\overline{CSI}$ Inactive to $\overline{CSO}_i^2$ Inactive	9	70	9	80	9	90	0	0	ns
T32	Direct PAD Input <sup>3</sup> as Hold Time	0		0		0		0	0	ns
T33	$R/\overline{W}$ Active to E or $\overline{DS}$ Start	30		40		50		0	0	ns
T34	E or $\overline{DS}$ End to $R/\overline{W}$	30		40		50		0	0	ns
T35	AS Inactive to E high	0		0		0		0	0	ns
T36	Address to Leading Edge of Write	30		35		40		0	0	ns

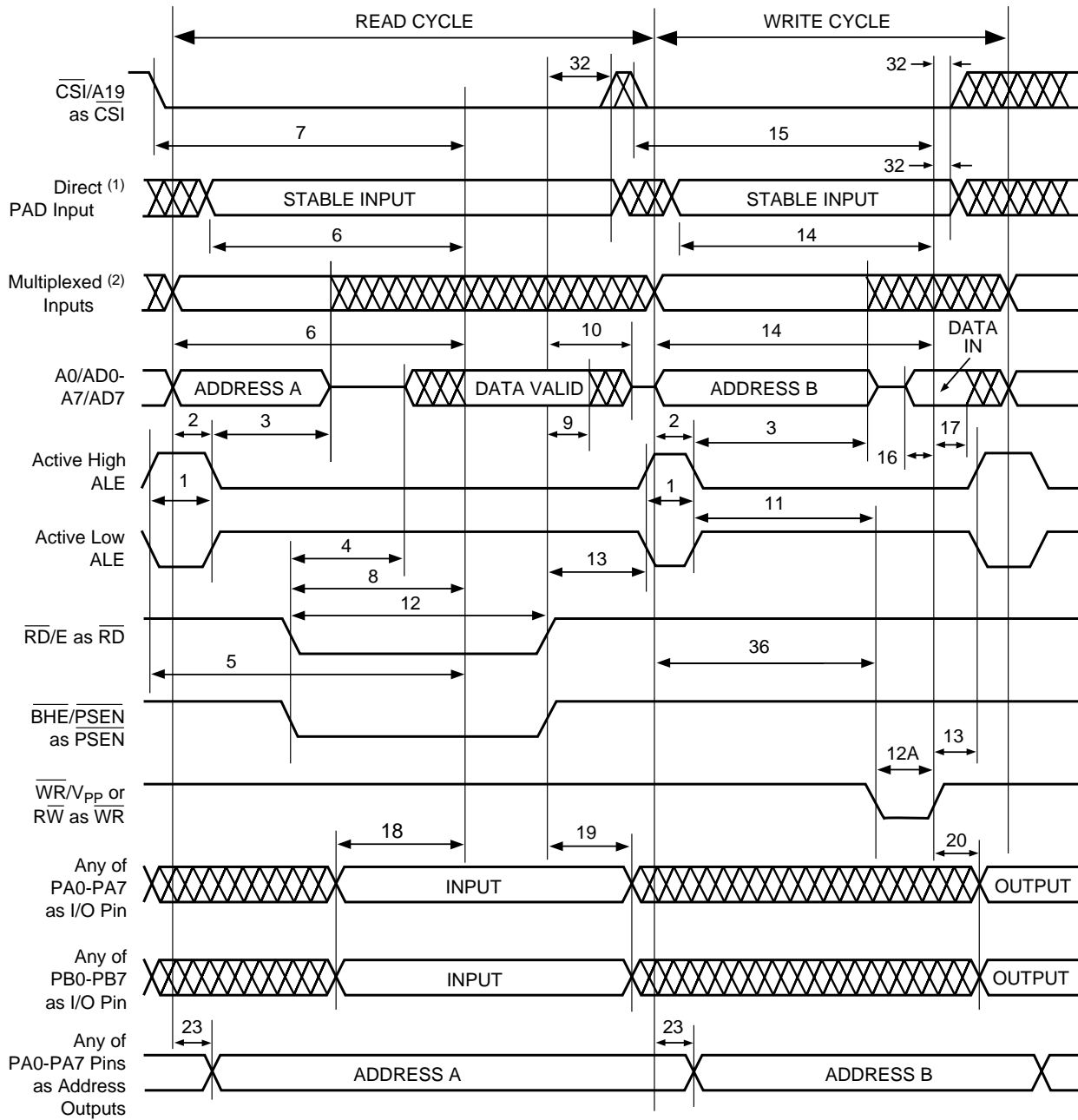
- NOTES:**
1. ADi = any address line.
  2.  $\overline{CSO}_i$  = any of the chip-select output signals coming through Port B ( $\overline{CS0}$ – $\overline{CS7}$ ) or through Port C ( $\overline{CS8}$ – $\overline{CS10}$ ).
  3. Direct PAD input = any of the following direct PAD input lines:  $\overline{CSI}/A19$  as transparent A19,  $\overline{RD}/E/DS$ ,  $\overline{WR}$  or  $R/\overline{W}$ , transparent PC0–PC2, ALE (or AS).
  4. Control signals  $\overline{RD}/E/DS$  or  $\overline{WR}$  or  $R/\overline{W}$ .

\*-15 speed available only on ZPSD311V.



### 18.9 Timing Diagrams for all PSD3XX Parts

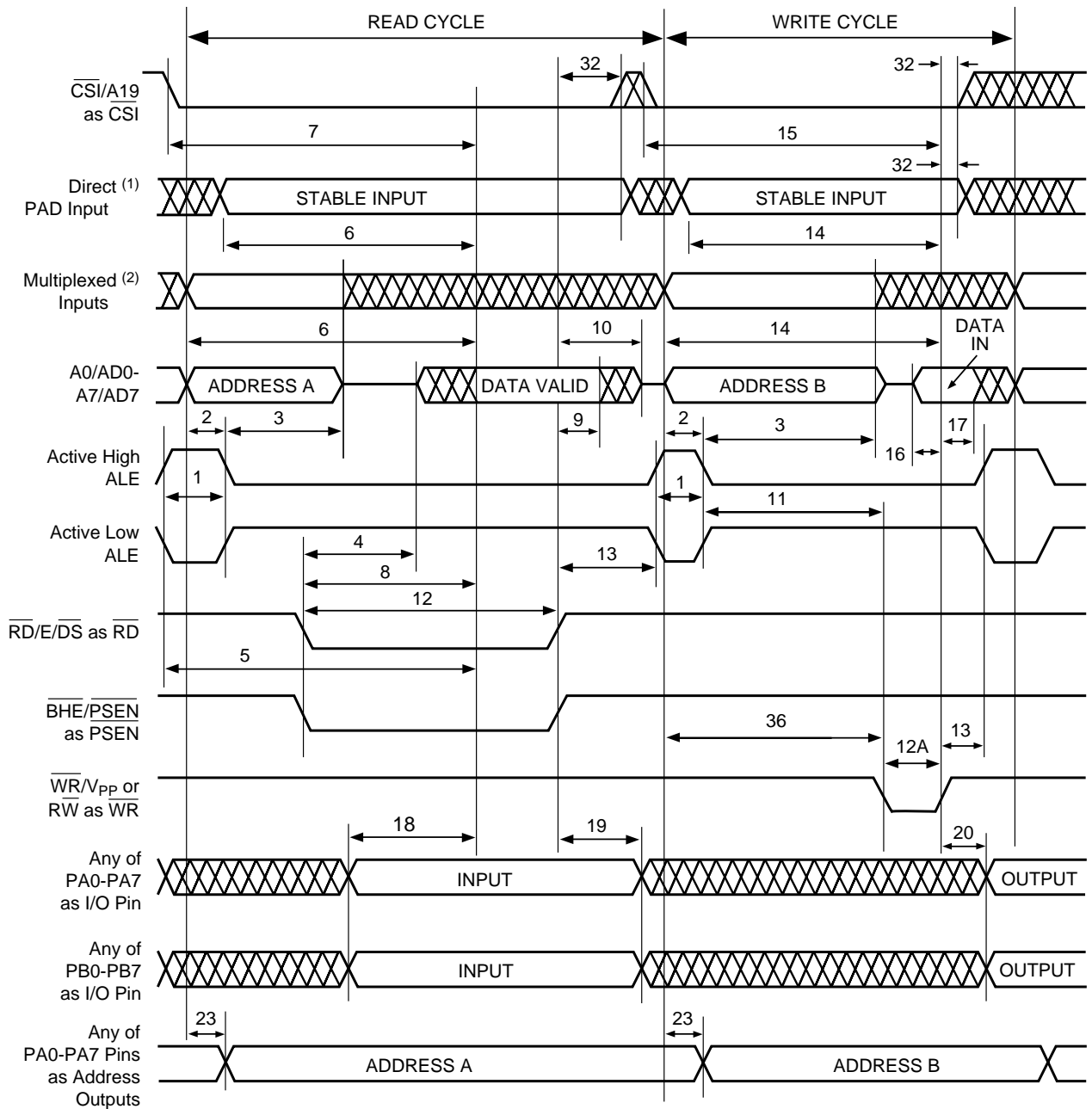
Figure 20. Timing of 8-Bit Multiplexed Address/Data Bus Using  $\overline{RD}$ ,  $\overline{WR}$  (PSD3X1)



See referenced notes on page 64.



Figure 21. Timing of 8-Bit Multiplexed Address/Data Bus Using  $\overline{RD}$ ,  $\overline{WR}$  (PSD3X2/3X3)

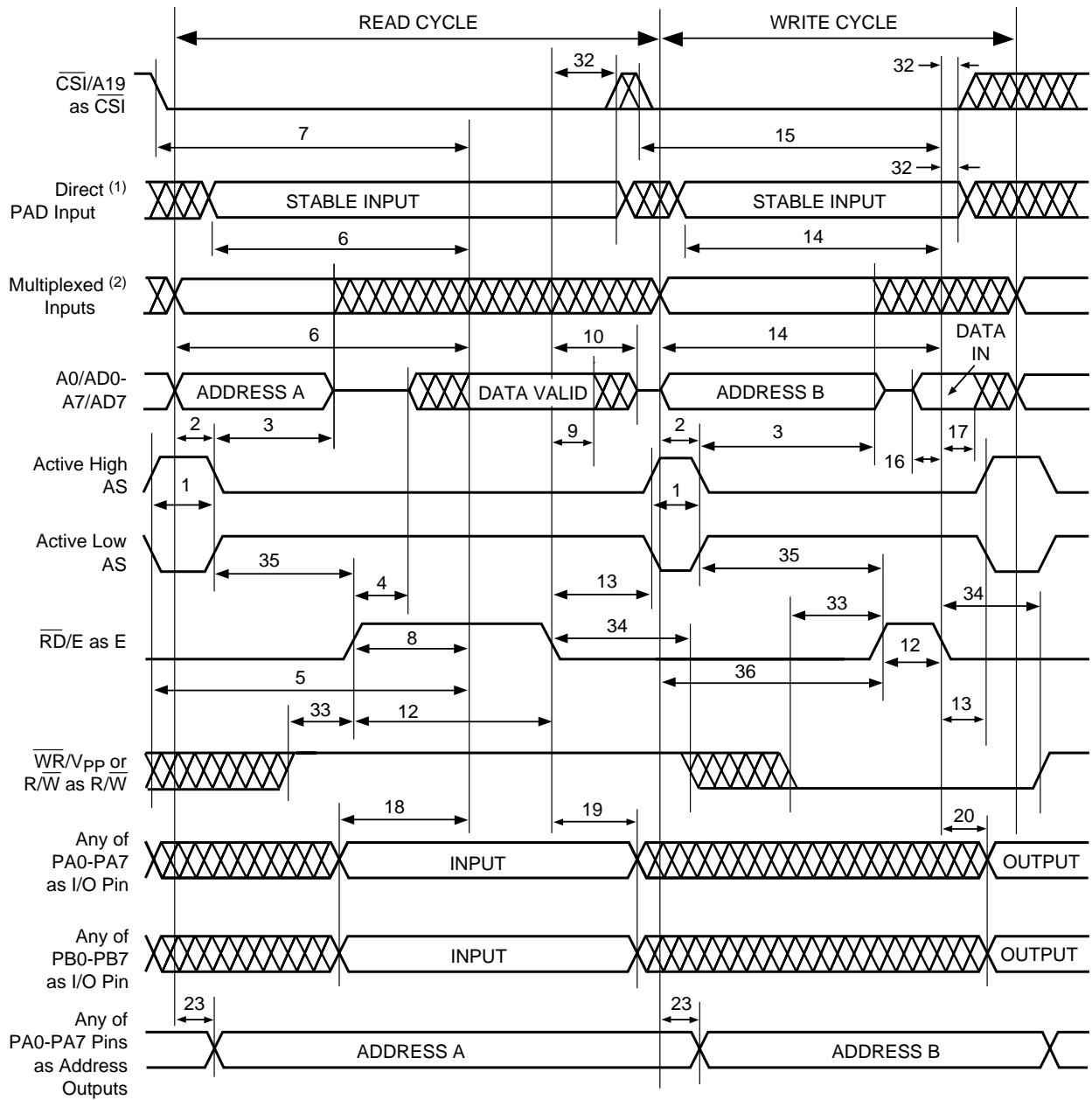


See referenced notes on page 64





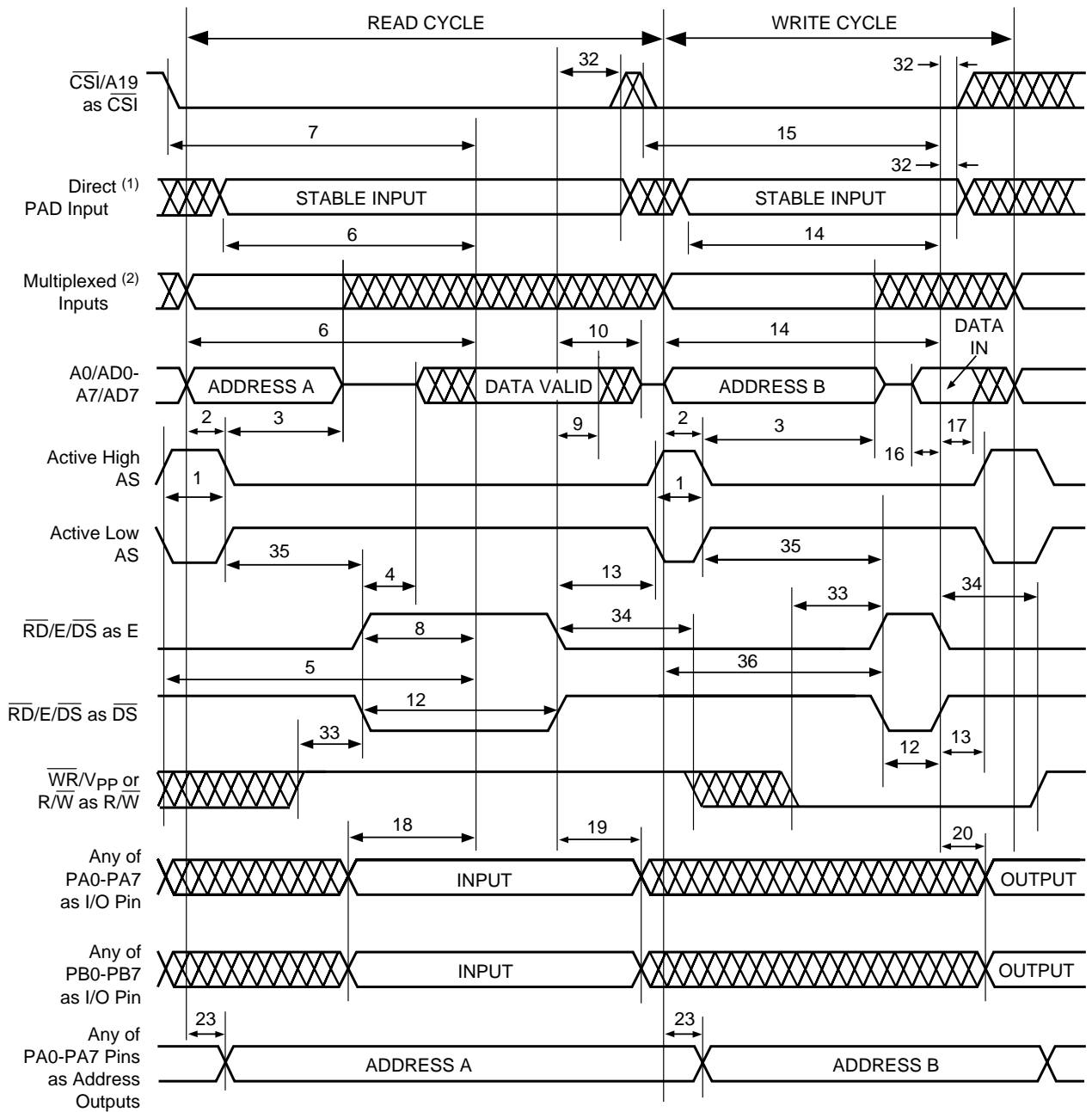
Figure 22. Timing of 8-Bit Multiplexed Address/Data Bus Using  $R/\overline{W}$ ,  $E$  or  $R/\overline{W}$ ,  $\overline{DS}$  (PSD3X1)



See referenced notes on page 64.



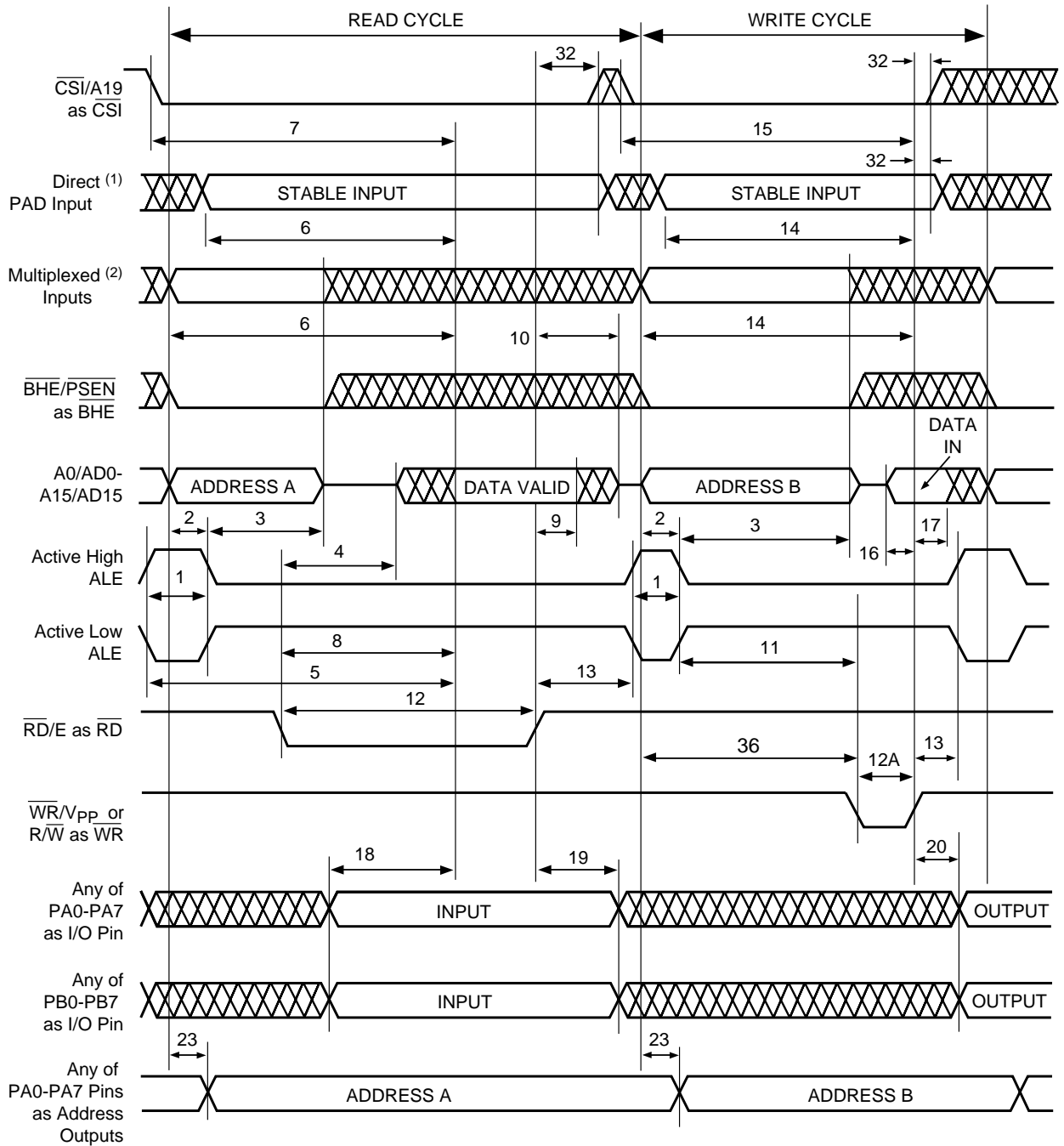
Figure 23. Timing of 8-Bit Multiplexed Address/Data Bus Using  $R/\overline{W}$ ,  $\overline{E}$  or  $R/\overline{W}$ ,  $\overline{DS}$  (PSD3X2/3X3)



See referenced notes on page 64.



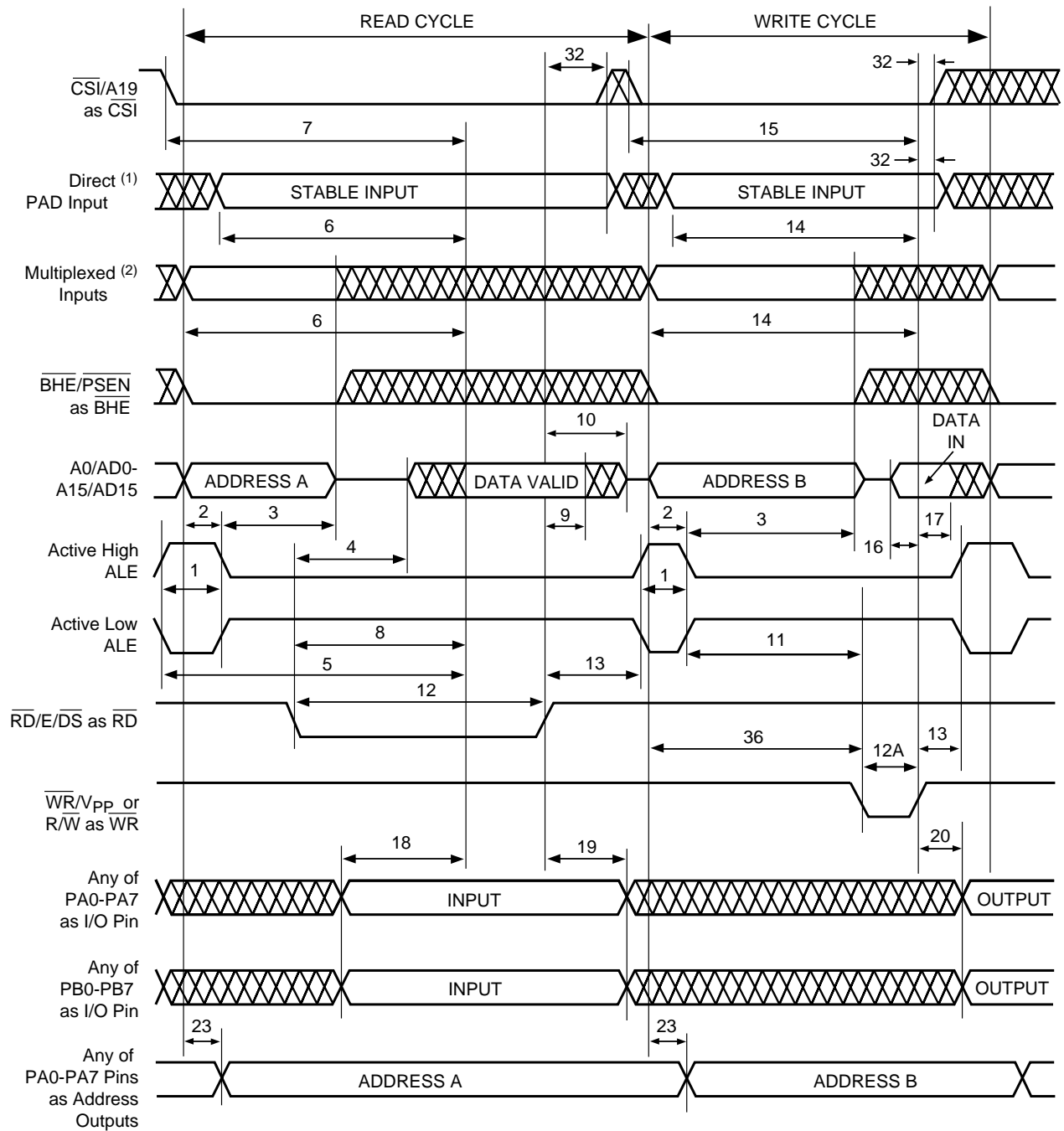
Figure 24. Timing of 16-Bit Multiplexed Address/Data Bus Using  $\overline{RD}$ ,  $\overline{WR}$  (PSD3X1)



See referenced notes on page 64.



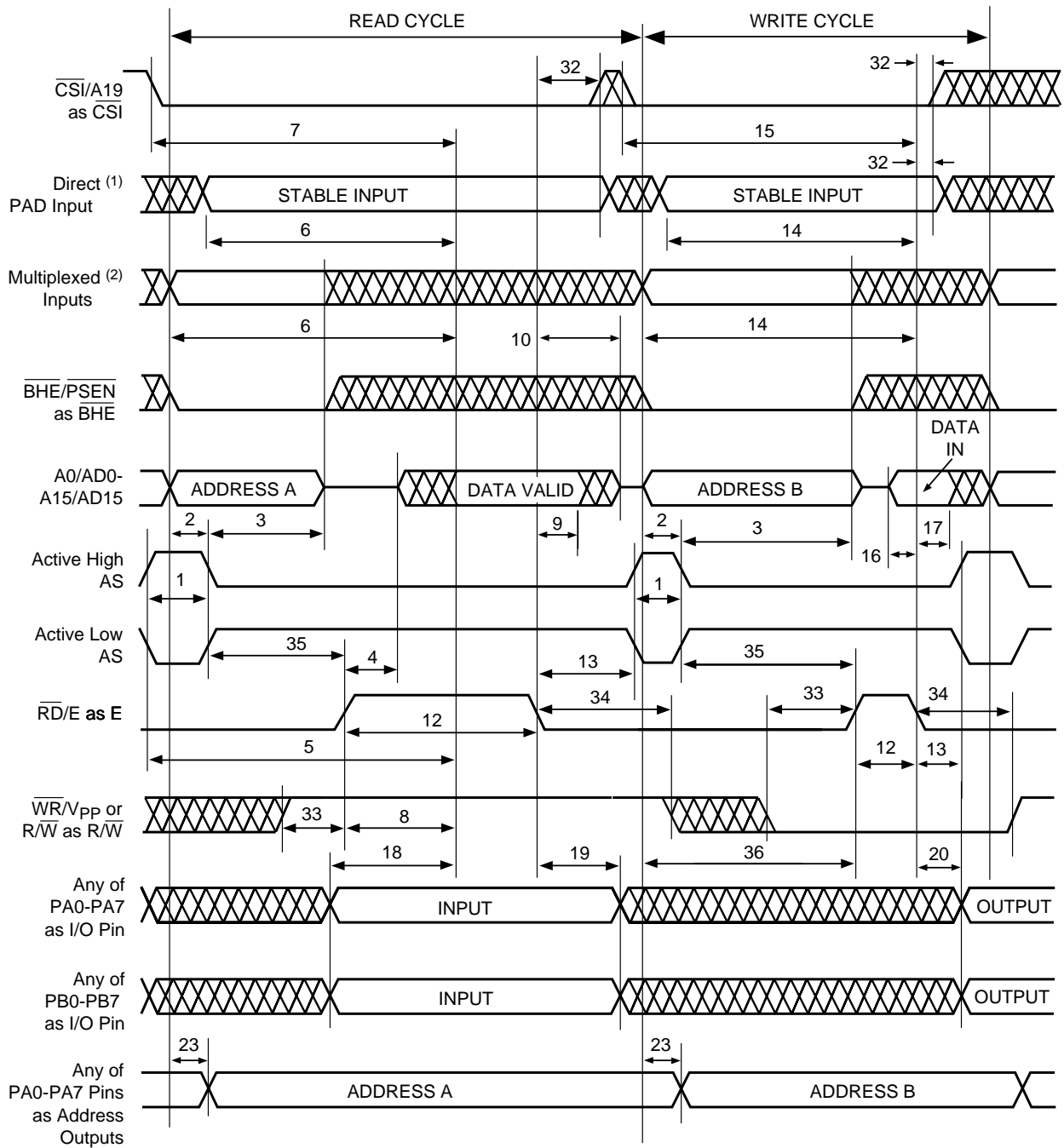
Figure 25. Timing of 16-Bit Multiplexed Address/Data Bus Using  $\overline{RD}$ ,  $\overline{WR}$  (PSD3X2/3X3)



See referenced notes on page 64.



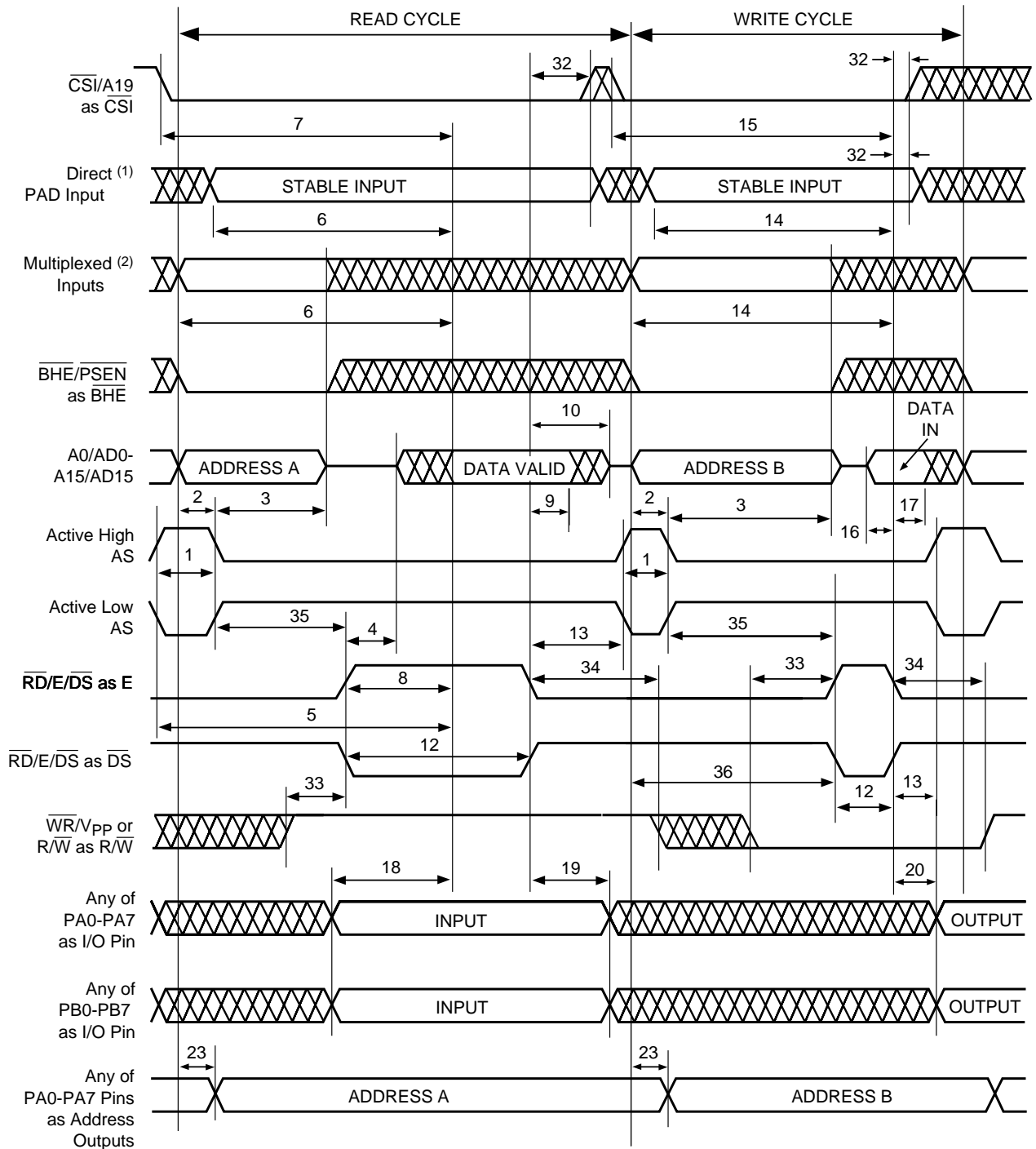
Figure 26. Timing of 16-Bit Multiplexed Address/Data Bus Using  $R/\overline{W}$ ,  $E$  or  $R/\overline{W}$ ,  $\overline{DS}$  (PSD3X1)



See referenced notes on page 64.



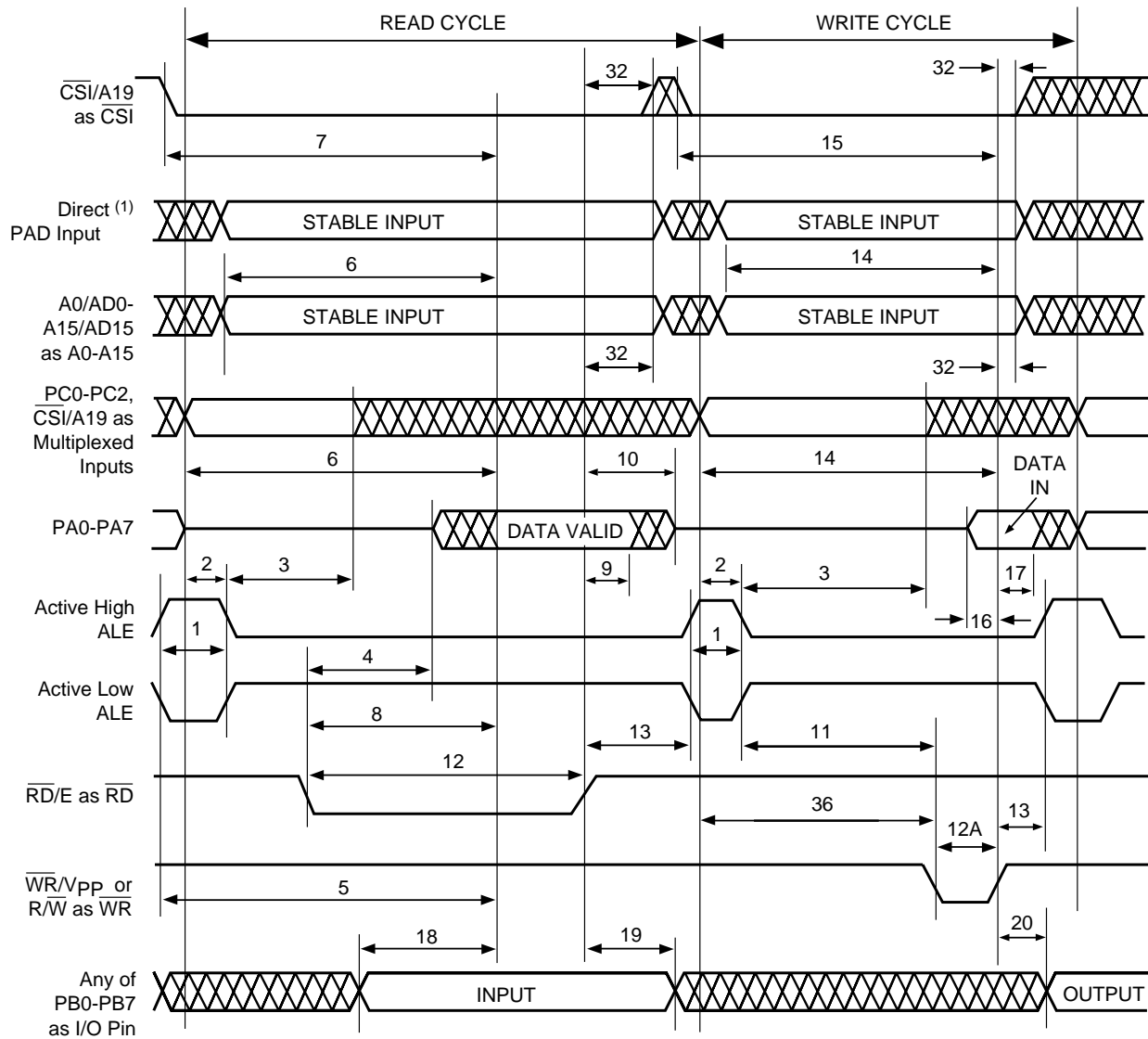
Figure 27. Timing of 16-Bit Multiplexed Address/Data Bus Using  $R/\overline{W}$ ,  $E$  or  $R/\overline{W}$ ,  $\overline{DS}$  (PSD3X2/3X3)



See referenced notes on page 64.

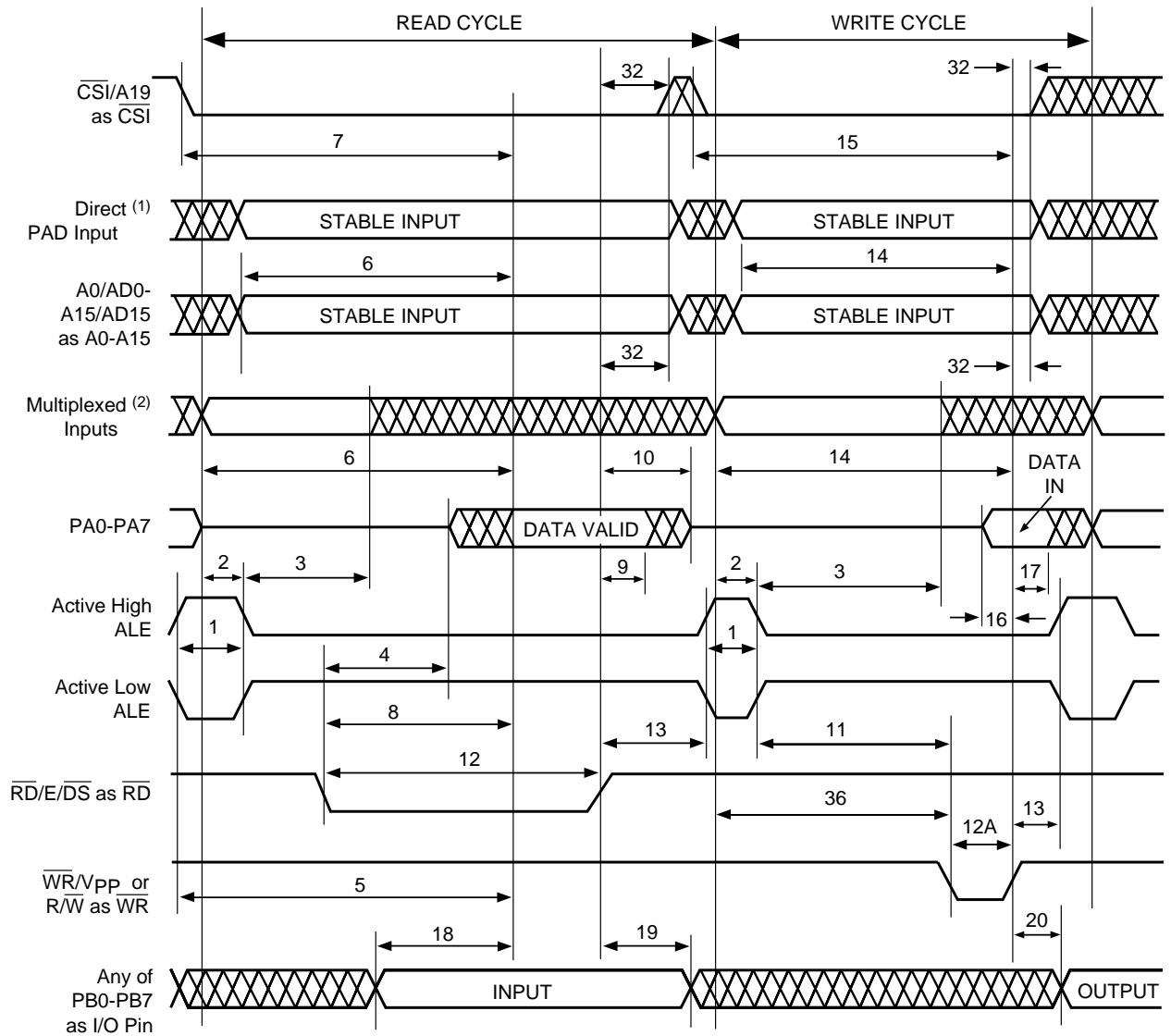


Figure 28. Timing of 8-Bit Non-Multiplexed Address/Data Bus Using  $\overline{RD}$ ,  $\overline{WR}$  (PSD3X1)



See referenced notes on page 64.

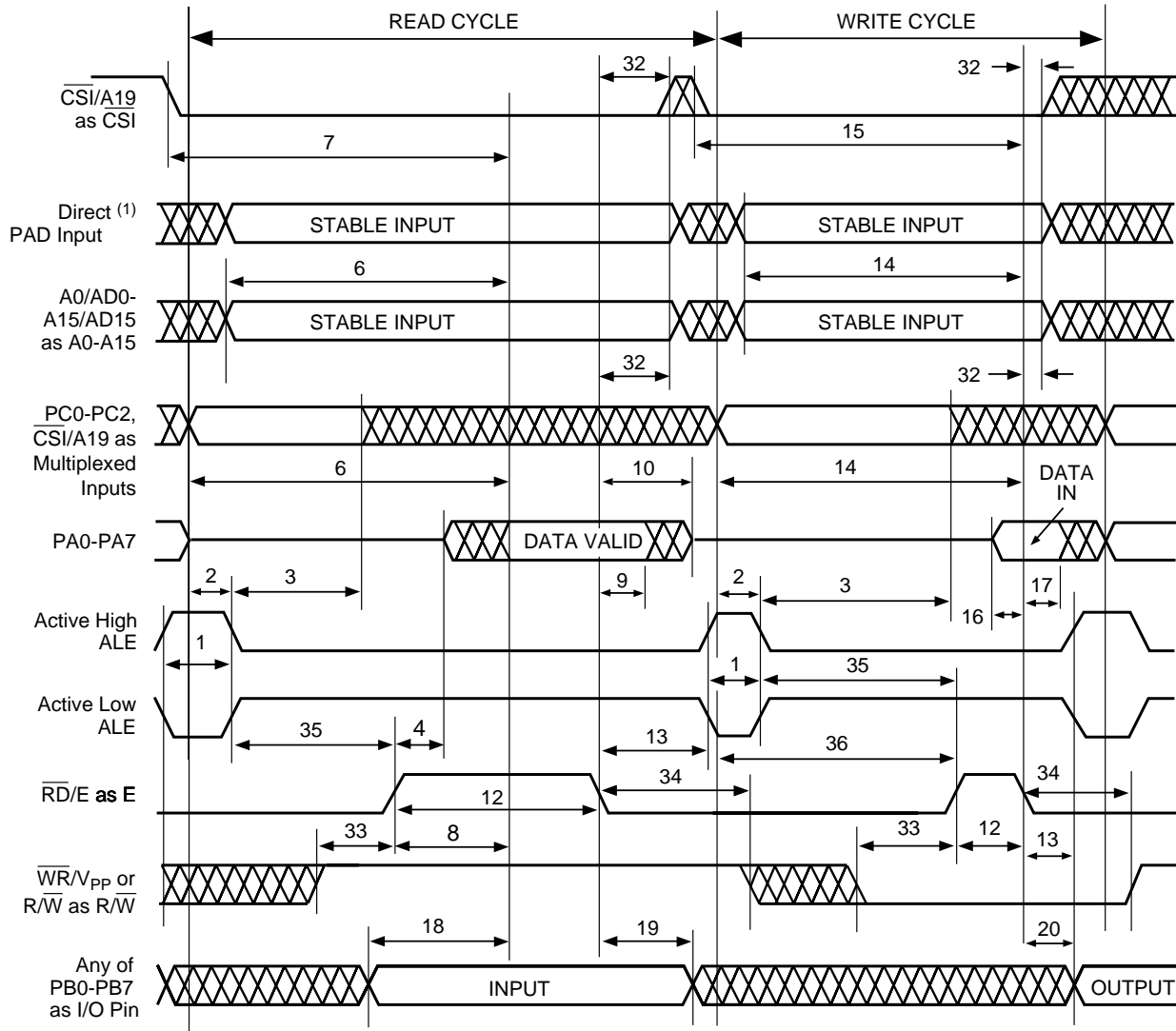
Figure 29. Timing of 8-Bit Non-Multiplexed Address/Data Bus Using  $\overline{RD}$ ,  $\overline{WR}$  (PSD3X2/3X3)



See referenced notes on page 64.

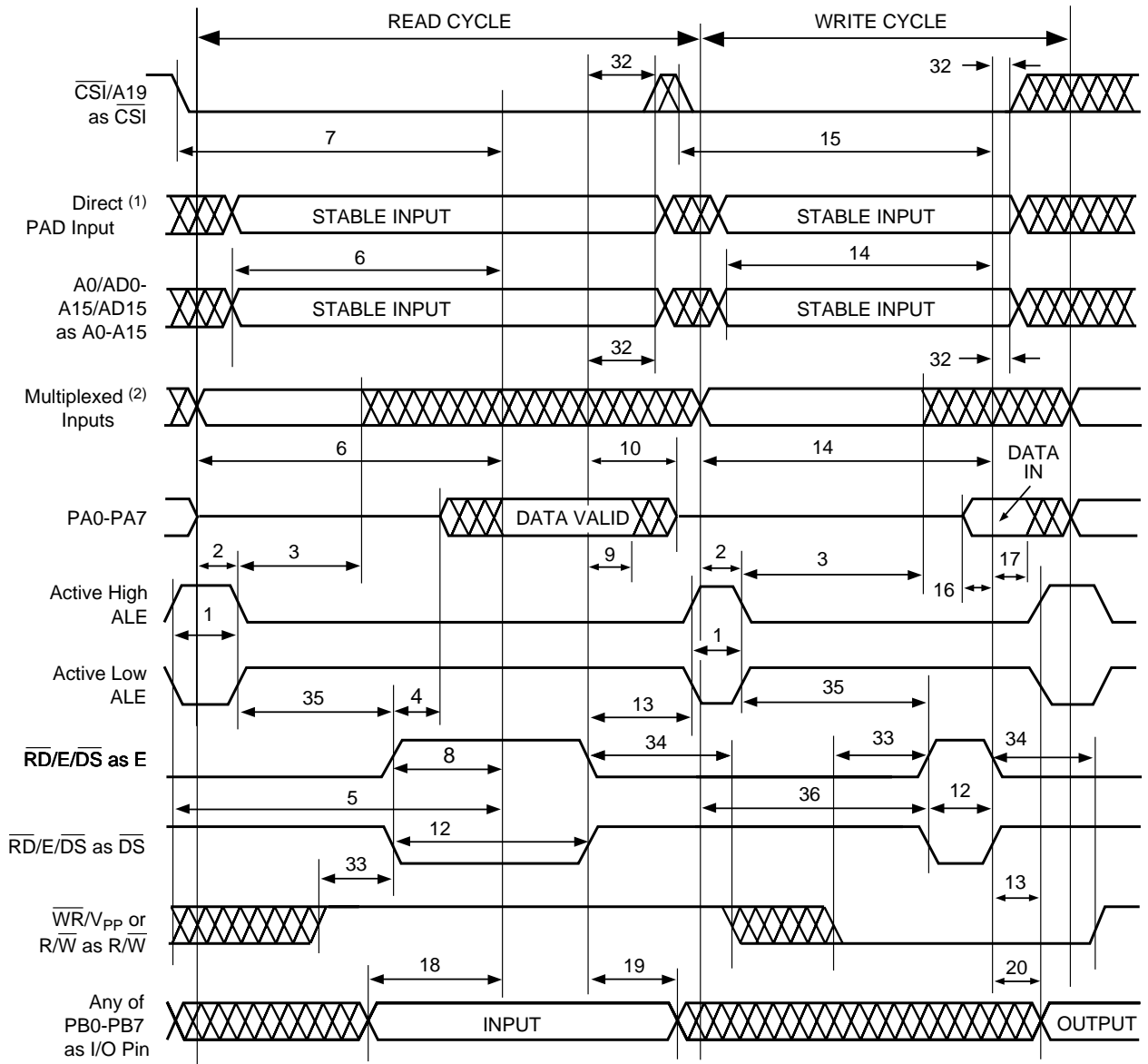


Figure 30. Timing of 8-Bit Non-Multiplexed Address/Data Bus Using  $R/\overline{W}$ ,  $E$  or  $R/\overline{W}$ ,  $\overline{DS}$  (PSD3X1)



See referenced notes on page 64.

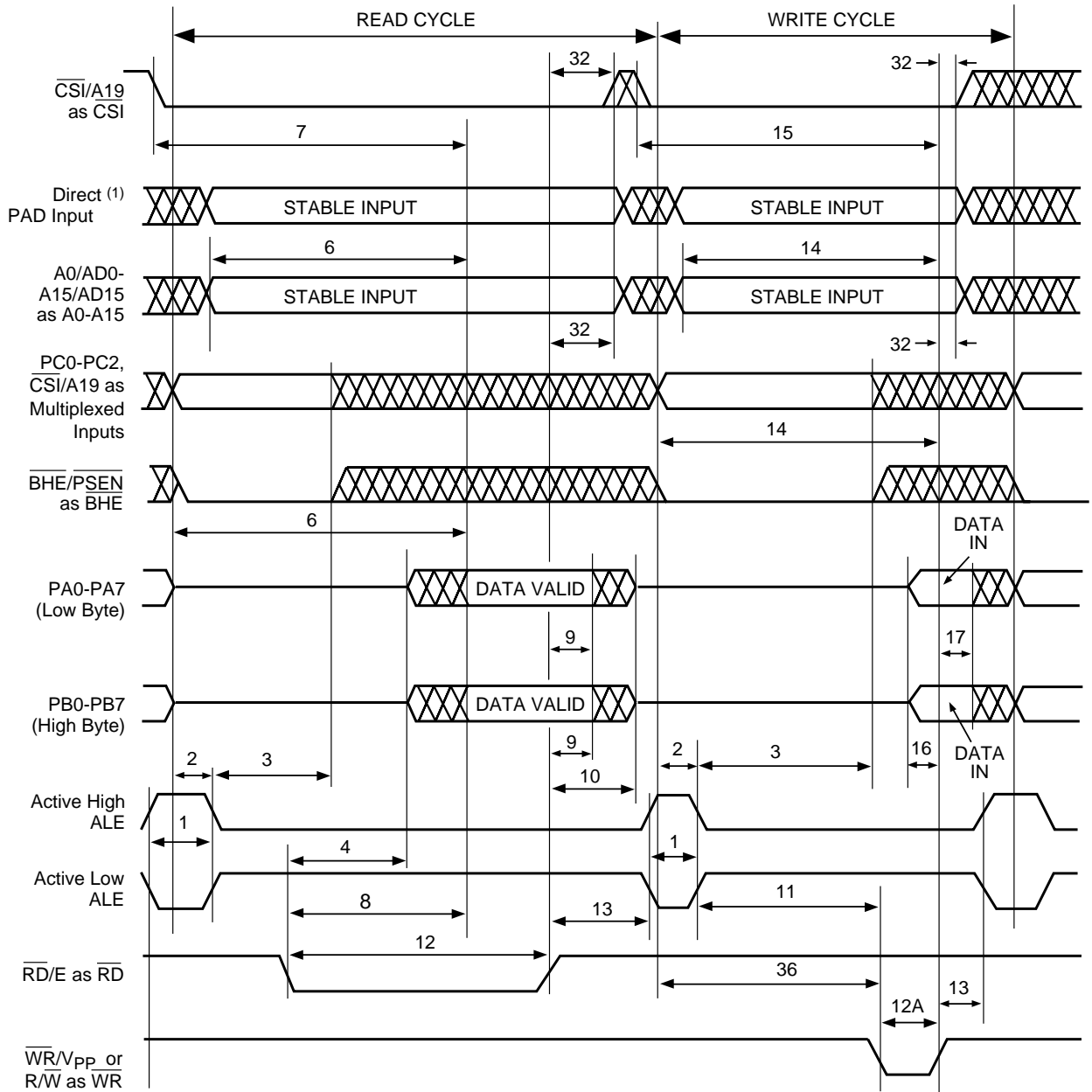
Figure 31. Timing of 8-Bit Non-Multiplexed Address/Data Bus Using  $R/\overline{W}$ ,  $E$  or  $R/\overline{W}$ ,  $\overline{DS}$  (PSD3X2/3X3)



See referenced notes on page 64.



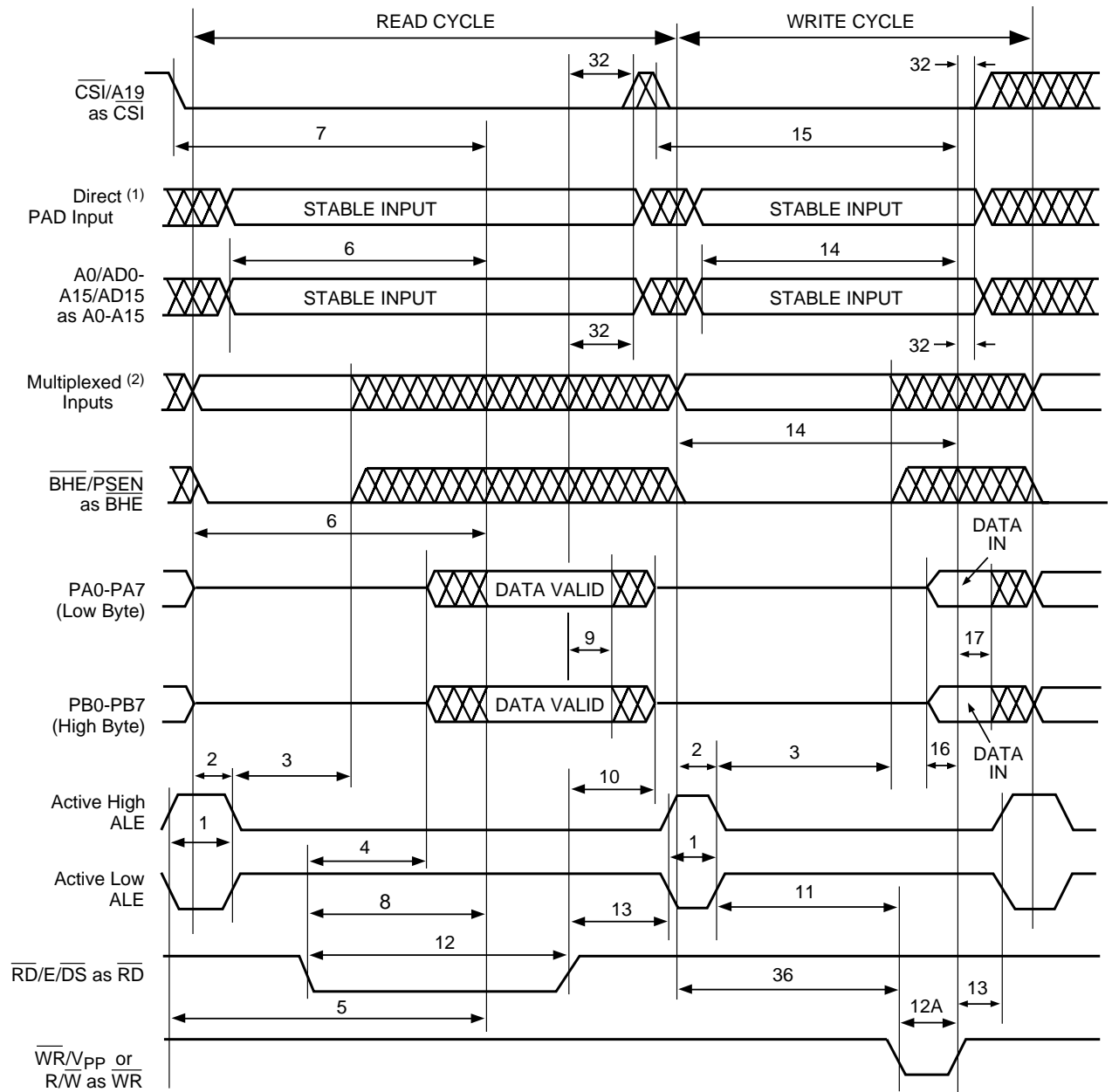
Figure 32. Timing of 16-Bit Non-Multiplexed Address/Data Bus Using  $\overline{RD}$ ,  $\overline{WR}$  (PSD3X1)



See referenced notes on page 64.



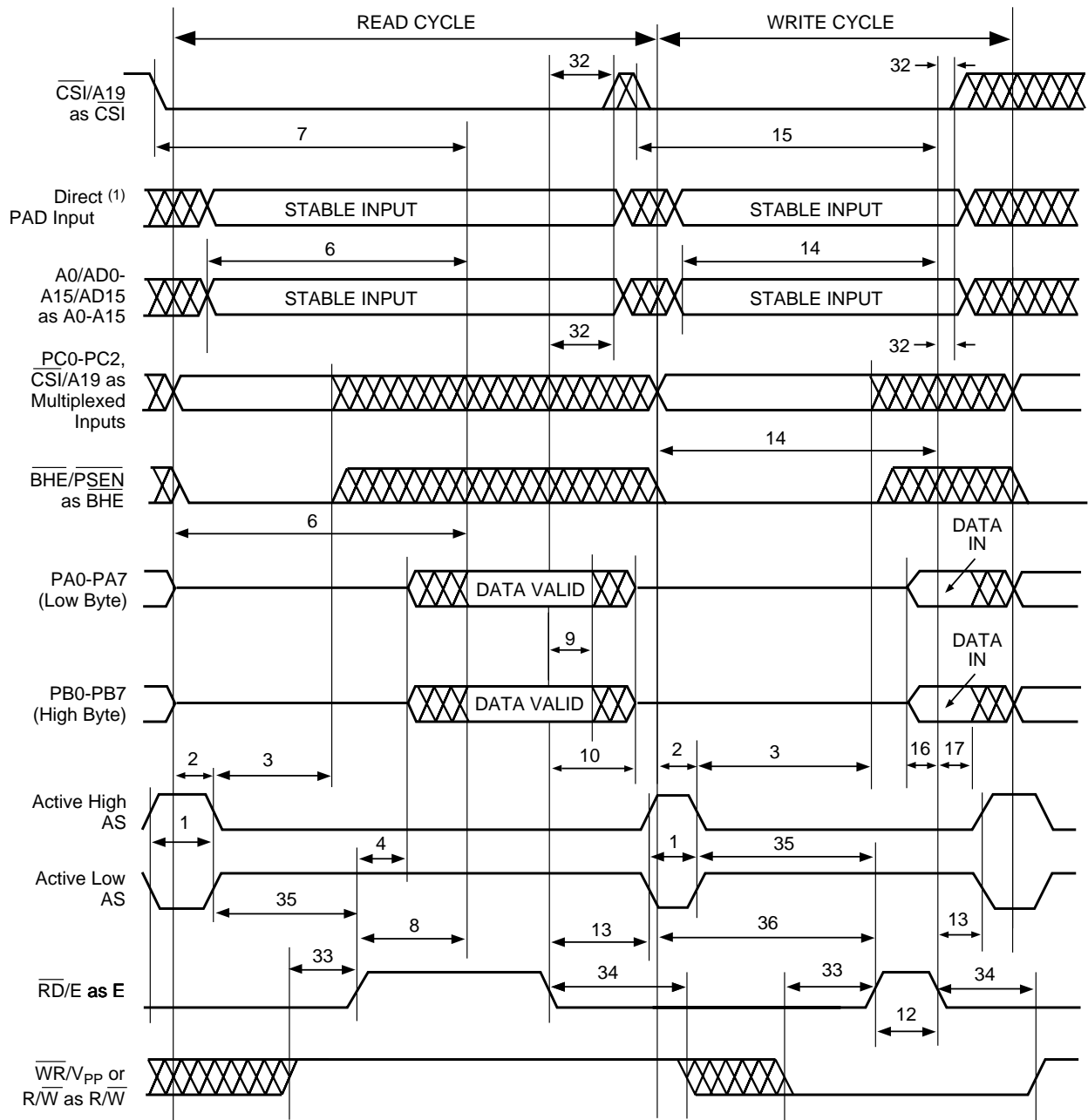
Figure 33. Timing of 16-Bit Non-Multiplexed Address/Data Bus Using  $\overline{RD}$ ,  $\overline{WR}$  (PSD3X2/3X3)



See referenced notes on page 64.

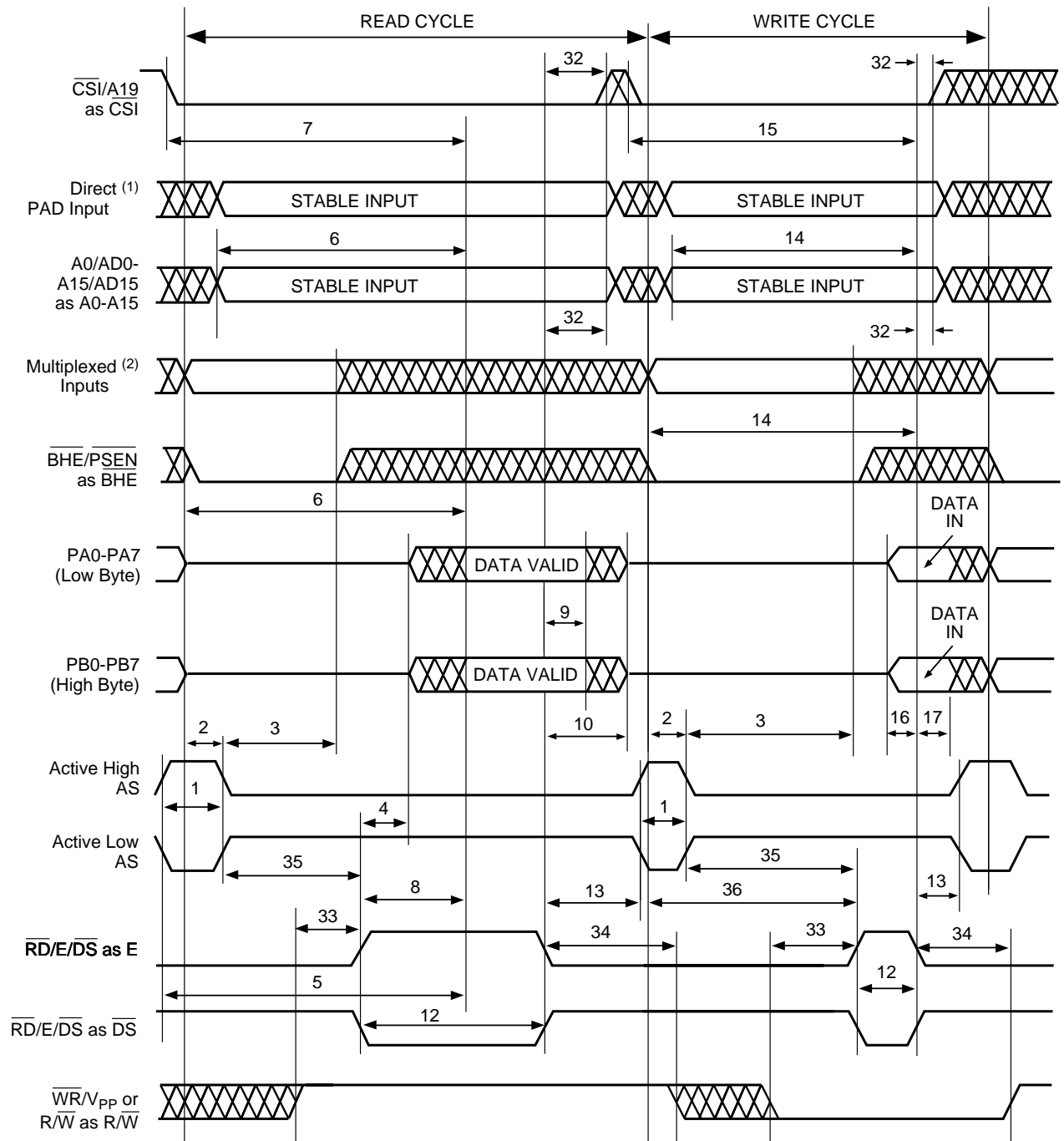


Figure 34. Timing of 16-Bit Non-Multiplexed Address/Data Bus Using  $R/\overline{W}$ ,  $E$  or  $R/\overline{W}$ ,  $\overline{DS}$  (PSD3X1)



See referenced notes on page 64.

Figure 35. Timing of 16-Bit Non-Multiplexed Address/Data Bus Using  $R\bar{W}$ ,  $E$  or  $R\bar{W}$ ,  $\bar{D}\bar{S}$  (PSD3X2/3X3)



See referenced notes on page 64.



Figure 36.  
Chip-Select  
Output Timing

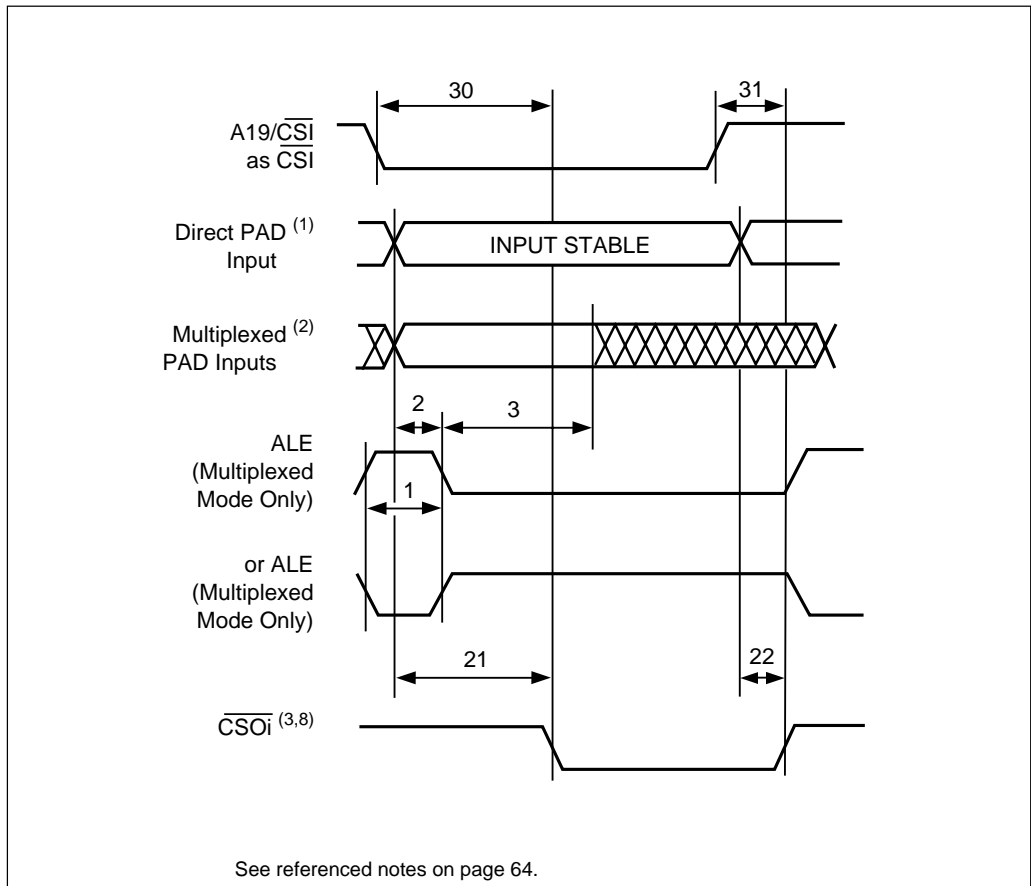
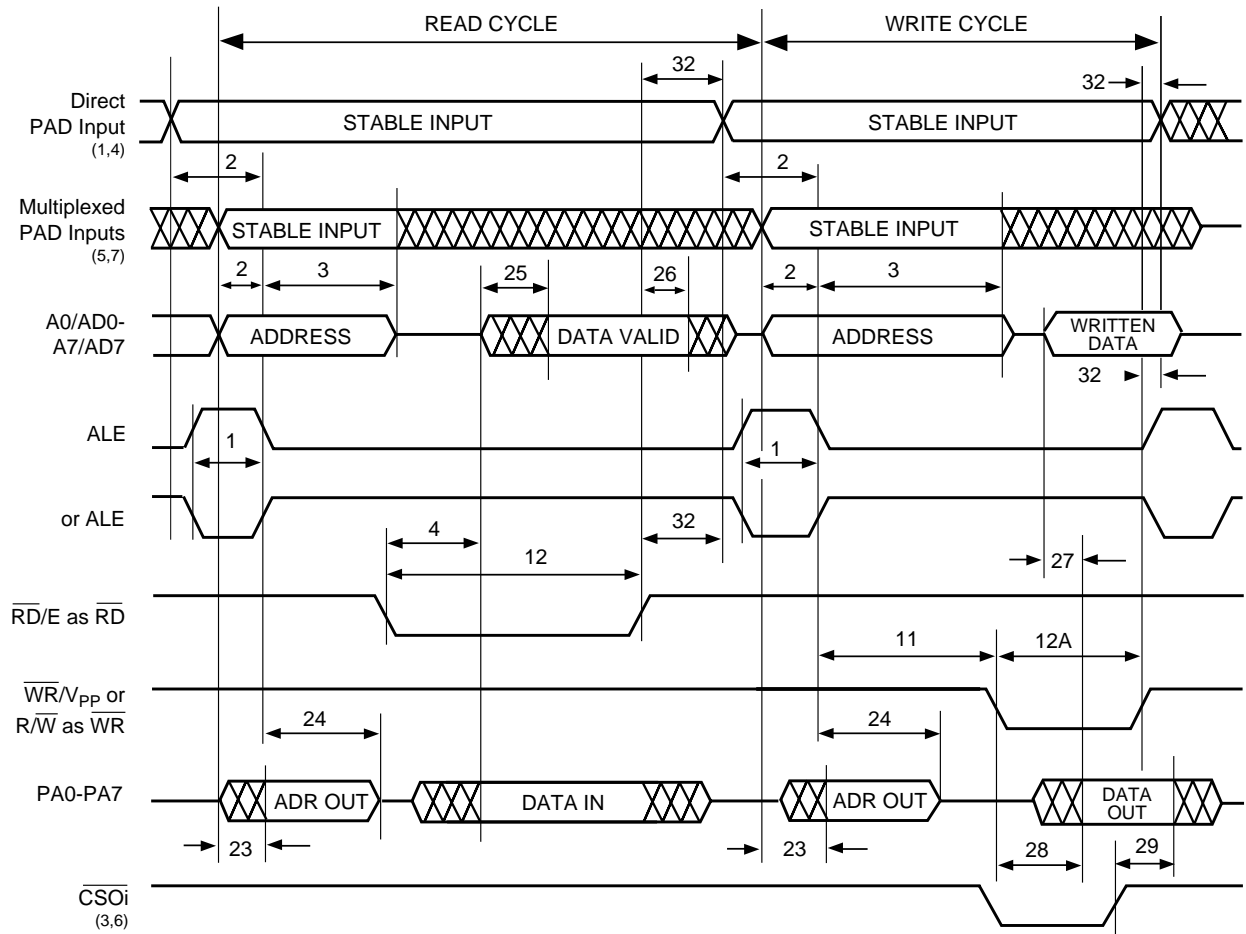
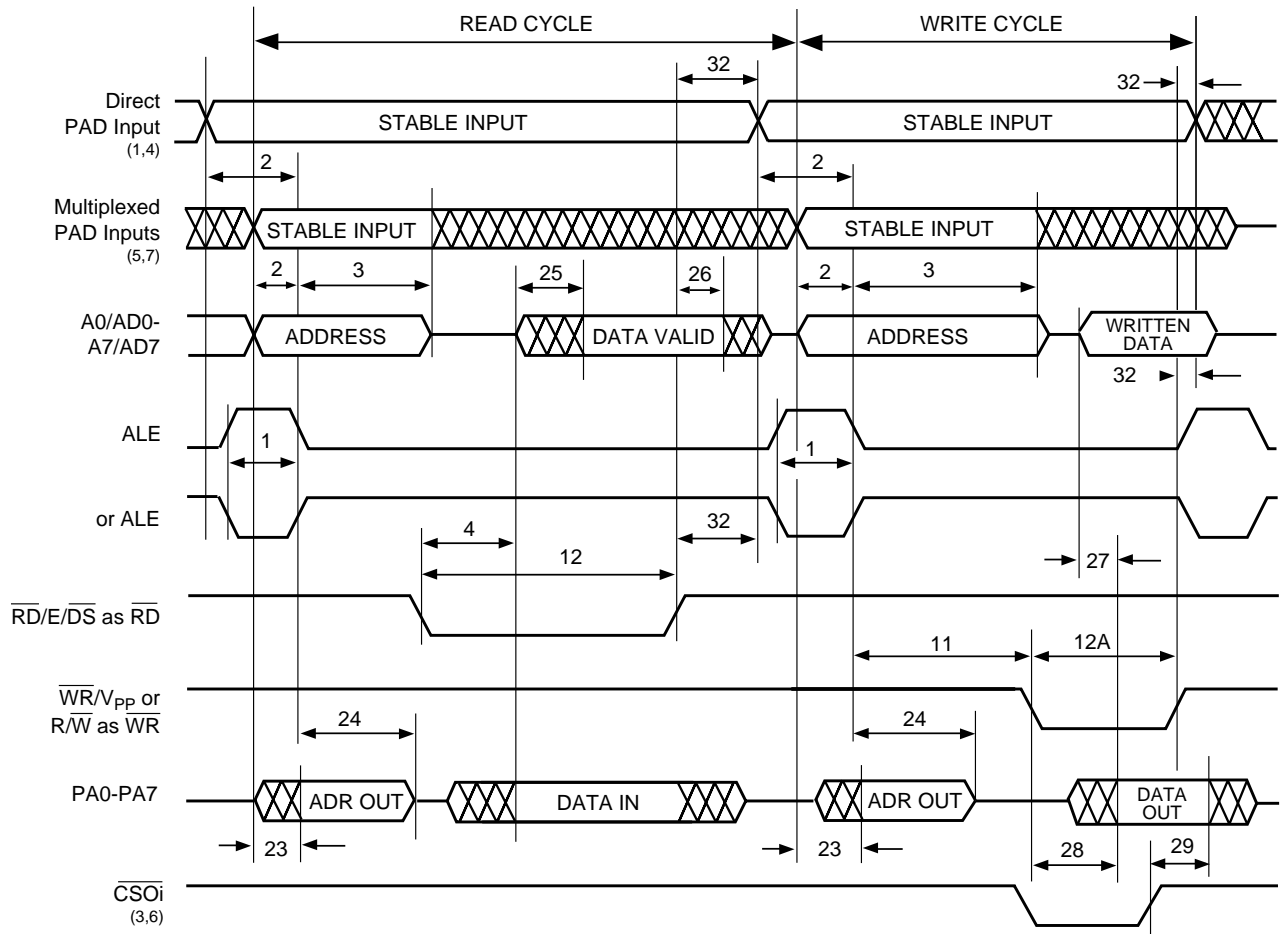


Figure 37. Port A as AD0–AD7 Timing (Track Mode) Using  $\overline{RD}$ ,  $\overline{WR}$  (PSD3X1)

See referenced notes on page 64.

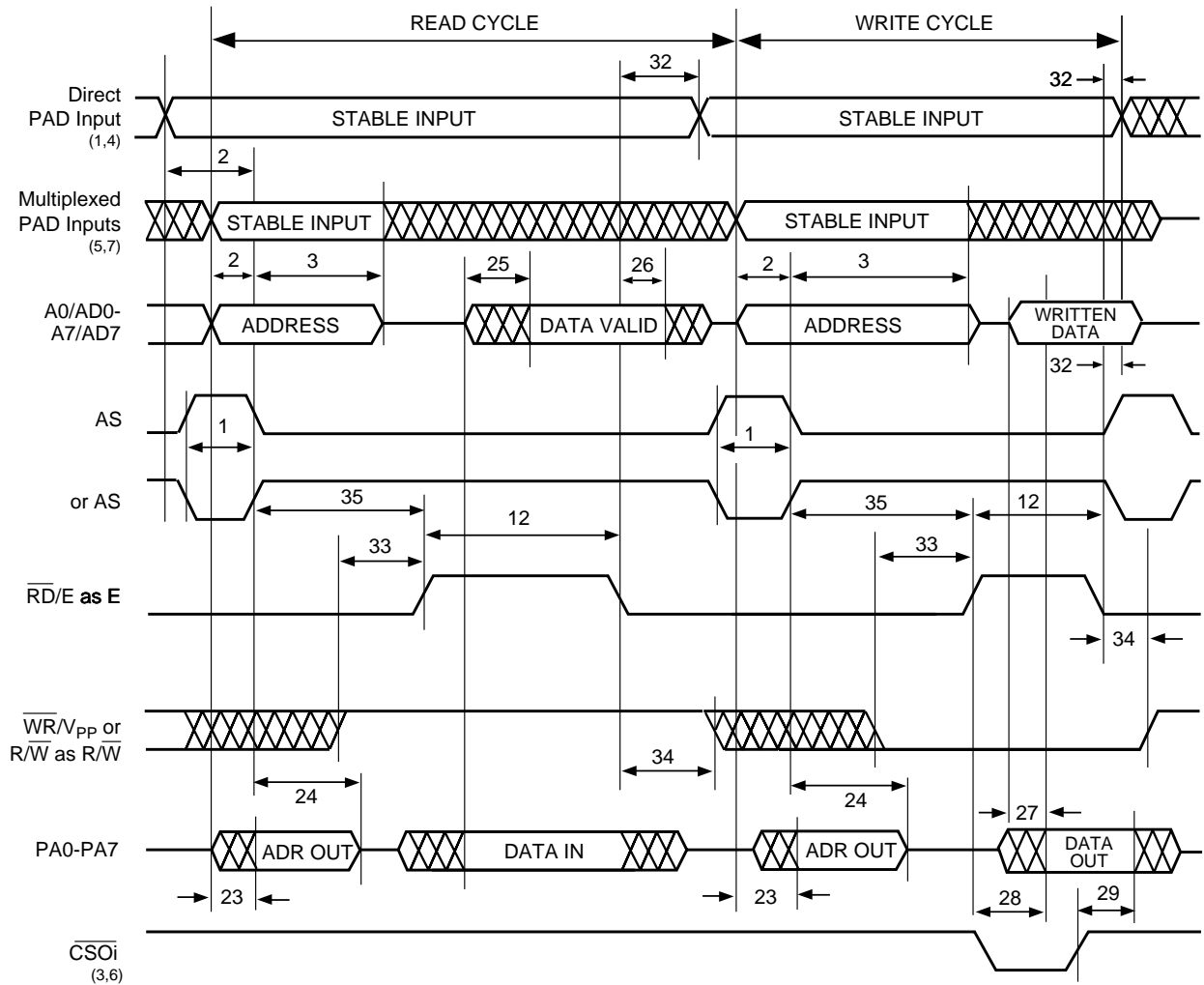


Figure 38. Port A as AD0-AD7 Timing (Track Mode) Using  $\overline{RD}$ ,  $\overline{WR}$  (PSD3X2/3X3)



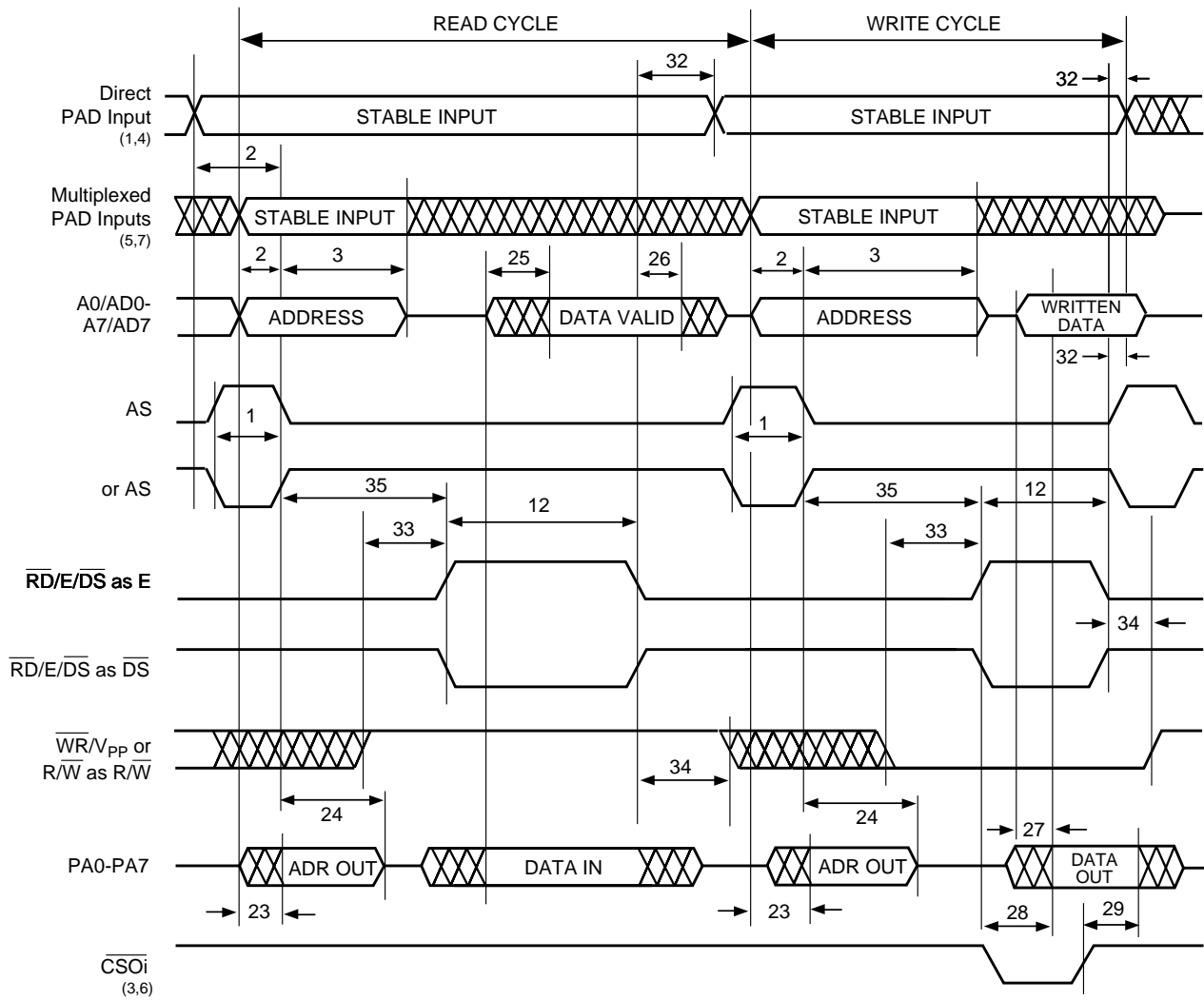
See referenced notes on page 64.

Figure 39. Port A as AD0–AD7 Timing (Track Mode) Using  $R/\overline{W}$ ,  $E$  or  $R/\overline{W}$ ,  $\overline{DS}$  (PSD3X1)



See referenced notes on page 64.

Figure 40. Port A as AD0–AD7 Timing (Track Mode) Using  $R/\overline{W}$ , E or  $R/\overline{W}$ ,  $\overline{DS}$  (PSD3X2/3X3)



Notes for Timing Diagrams

1. Direct PAD input = any of the following direct PAD input lines: CSi/A19 as transparent A19,  $\overline{RD}/E/\overline{DS}$ ,  $\overline{WR}$  or  $R/\overline{W}$ , transparent PC0–PC2, ALE in non-multiplexed modes.
2. Multiplexed inputs: any of the following inputs that are latched by the ALE (or AS): A0/AD0–A15/AD15,  $\overline{CSi}/A19$  as ALE dependent A19, ALE dependent PC0–PC2.
3.  $\overline{CS0i}$  = any of the chip-select output signals coming through Port B ( $\overline{CS0}$ – $\overline{CS7}$ ) or through Port C ( $\overline{CS8}$ – $\overline{CS10}$ ).
4. CSADOUT1, which internally enables the address transfer to Port A, should be derived only from direct PAD input signals, otherwise the address propagation delay is slowed down.
5. CSADIN and CSADOUT2, which internally enable the data-in or data-out transfers, respectively, can be derived from any combination of direct PAD inputs and multiplexed PAD inputs.
6. The write operation signals are included in the  $\overline{CS0i}$  expression.
7. Multiplexed PAD inputs: any of the following PAD inputs that are latched by the ALE (or AS) in the multiplexed modes: A11/AD11–A15/AD15,  $\overline{CSi}/A19$  as ALE dependent A19, ALE dependent PC0–PC2.
8.  $\overline{CS0i}$  product terms can include any of the PAD input signals shown in Figure 3, except for reset and  $\overline{CSi}$ .



## 18.10 AC Testing

Figure 41A. AC Testing Input/Output Waveform (5 V Versions)

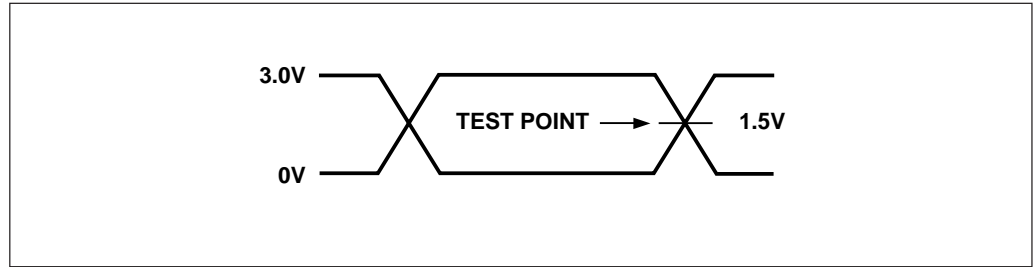


Figure 41B. AC Testing Input/Output Waveform (3 V Versions)

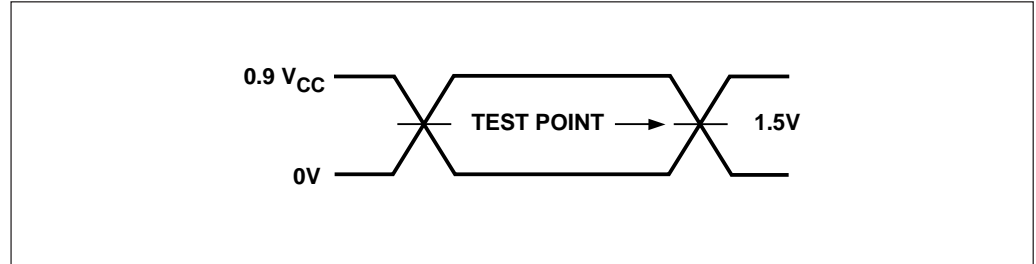


Figure 42A. AC Testing Load Circuit (5 V Versions)

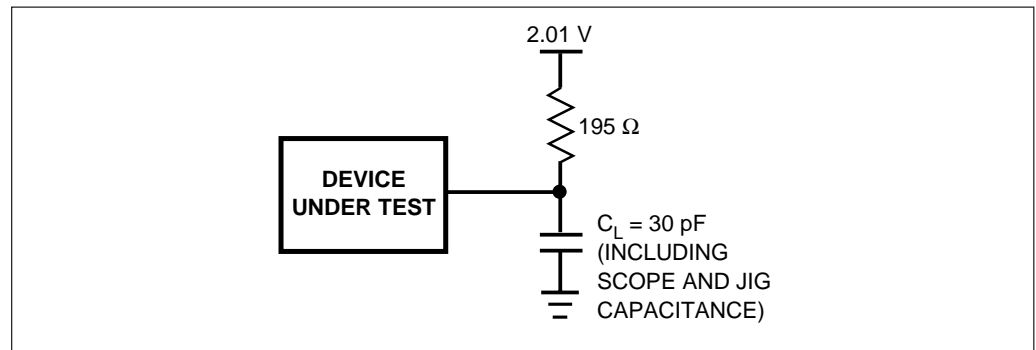
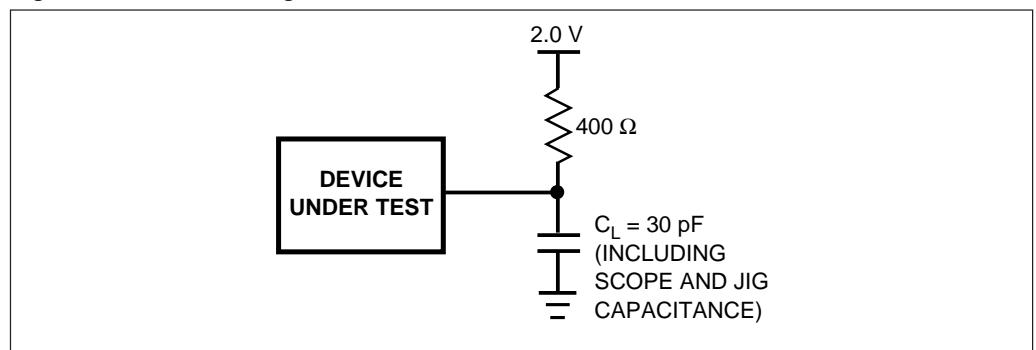


Figure 42B. AC Testing Load Circuit (3 V Versions)



### 19.0 Pin Assignments

Pin Name	44-Pin PLDCC/CLDCC Package	44-Pin PQFP/TQFP Package
$\overline{\text{BHE}}/\overline{\text{PSEN}}$	1	39
$\overline{\text{WR}}/\text{V}_{\text{PP}}$ or $\text{R}/\overline{\text{W}}$	2	40
RESET	3	41
PB7	4	42
PB6	5	43
PB5	6	44
PB4	7	1
PB3	8	2
PB2	9	3
PB1	10	4
PB0	11	5
GND	12	6
ALE or AS	13	7
PA7	14	8
PA6	15	9
PA5	16	10
PA4	17	11
PA3	18	12
PA2	19	13
PA1	20	14
PA0	21	15
$\overline{\text{RD}}/\text{E}$	22	16
AD0/A0	23	17
AD1/A1	24	18
AD2/A2	25	19
AD3/A3	26	20
AD4/A4	27	21
AD5/A5	28	22
AD6/A6	29	23
AD7/A7	30	24
AD8/A8	31	25
AD9/A9	32	26
AD10/A10	33	27
GND	34	28
AD11/A11	35	29
AD12/A12	36	30
AD13/A13	37	31
AD14/A14	38	32
AD15/A15	39	33
PC0	40	34
PC1	41	35
PC2	42	36
A19/ $\overline{\text{CS}}$	43	37
V <sub>CC</sub>	44	38



20.0  
Package  
Information

Figure 43.  
Drawing J2 –  
44 Pin Plastic  
Leaded Chip  
Carrier (PLDCC)  
without Window  
(Package Type J)

OR

Drawing L4 –  
44 Pin Ceramic  
Leaded Chip  
Carrier (CLDCC)  
with Window  
(Package Type L)

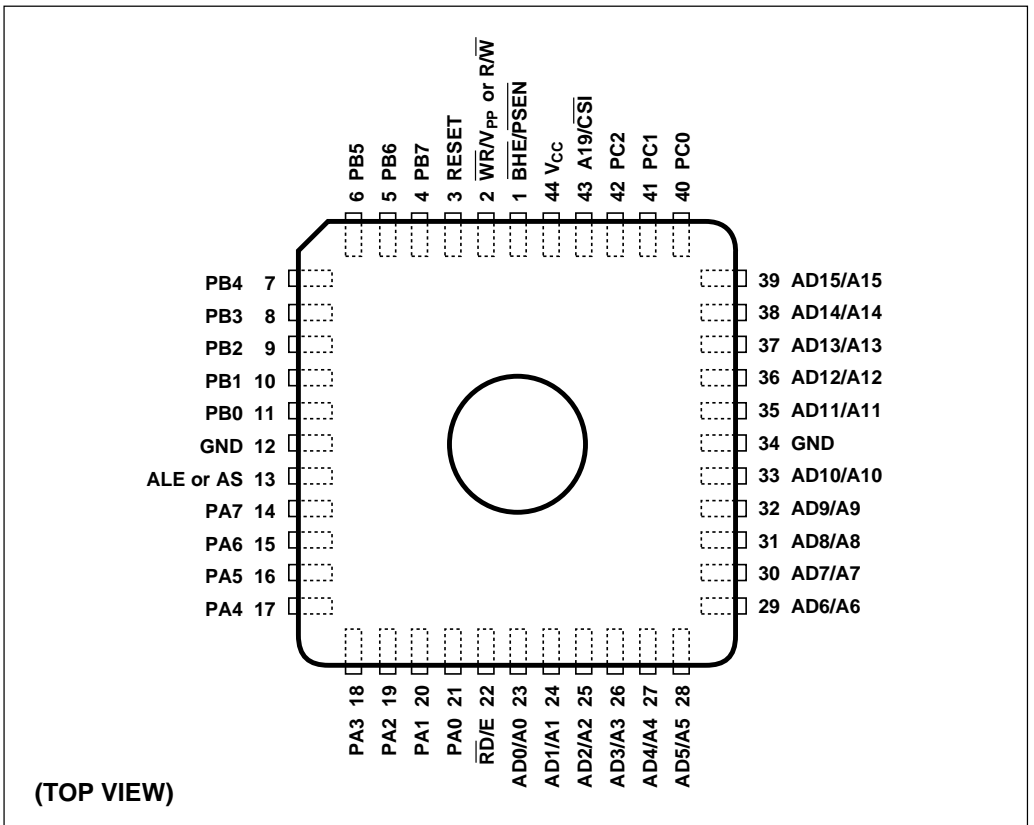
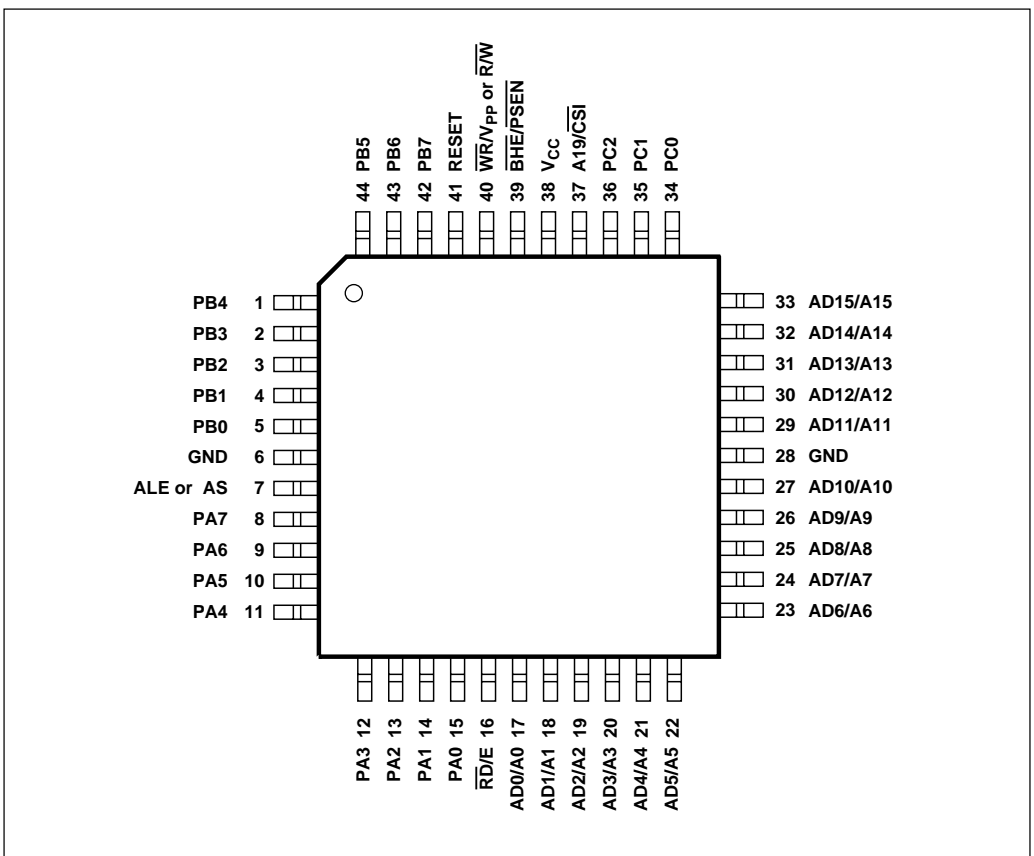


Figure 44.  
Drawing M1 –  
44 Pin Plastic Quad  
Flatpack (PQFP)  
(Package Type M)

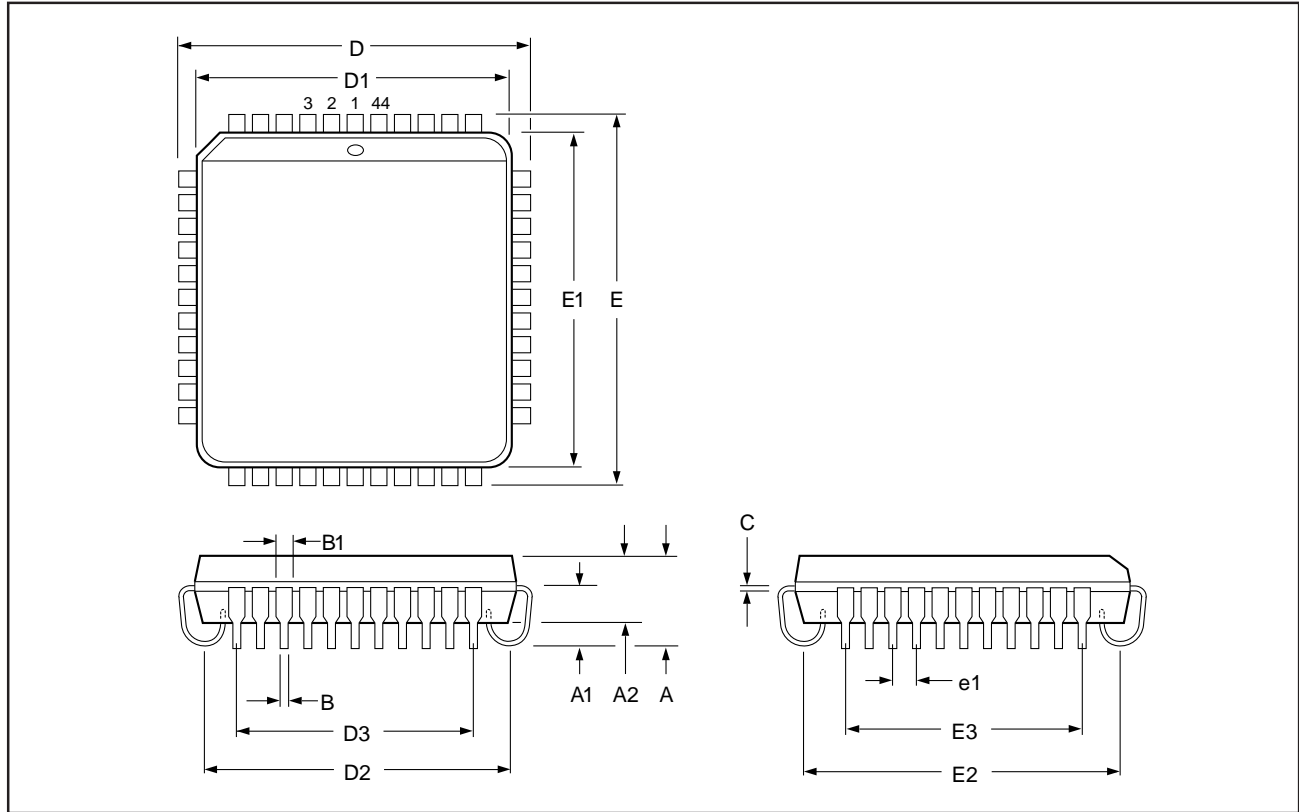
OR

Drawing U1 –  
44 Pin Plastic  
Thin Quad Flatpack  
(TQFP)  
(Package Type U)



21.0 Package Drawings

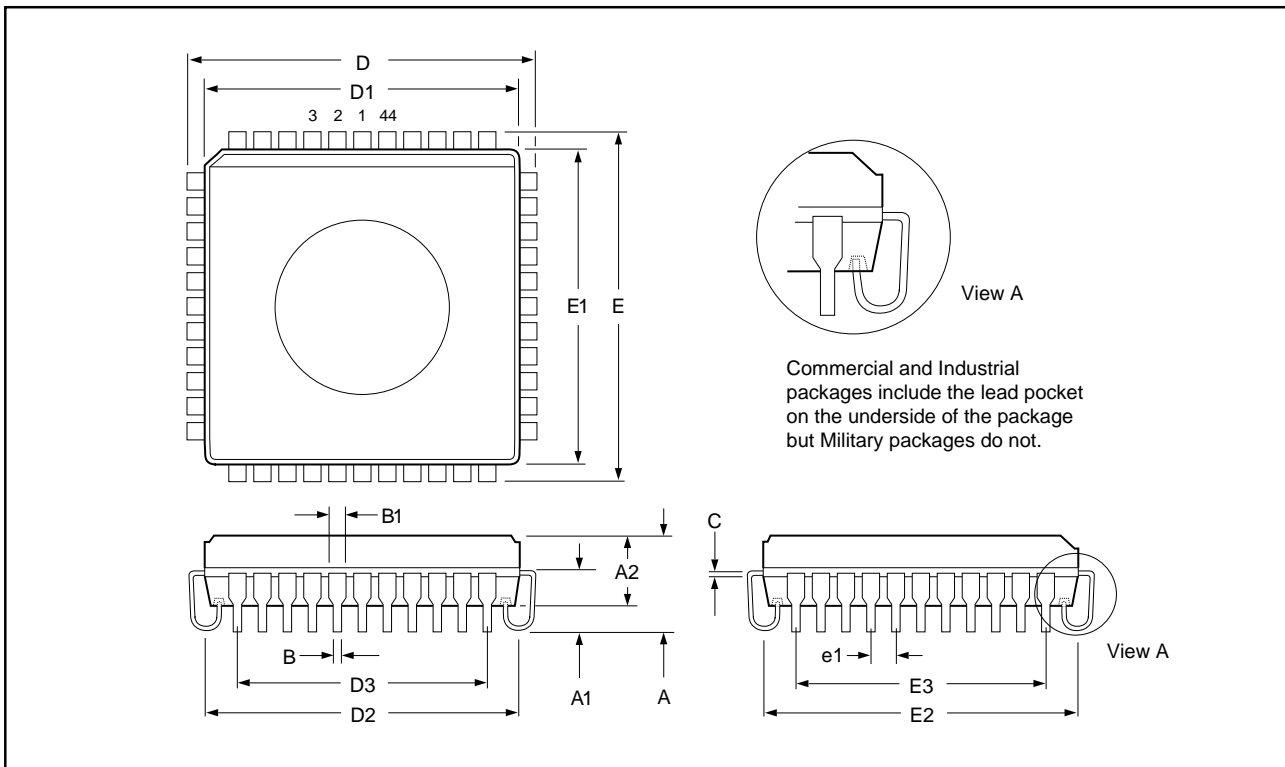
Drawing J2 – 44-Pin Plastic Leaded Chip Carrier (PLDCC) (Package Type J)



Family: Plastic Leaded Chip Carrier

Symbol	Millimeters			Inches		
	Min	Max	Notes	Min	Max	Notes
A	4.19	4.57		0.165	0.180	
A1	2.54	2.79		0.100	0.110	
A2	3.76	3.96		0.148	0.156	
B	0.33	0.53		0.013	0.021	
B1	0.66	0.81		0.026	0.032	
C	0.246	0.262		0.0097	0.0103	
D	17.40	17.65		0.685	0.695	
D1	16.51	16.61		0.650	0.654	
D2	14.99	16.00		0.590	0.630	
D3	12.70		Reference	0.500		Reference
E	17.40	17.65		0.685	0.695	
E1	16.51	16.61		0.650	0.654	
E2	14.99	16.00		0.590	0.630	
E3	12.70		Reference	0.500		Reference
e1	1.27		Reference	0.050		Reference
N	44			44		

## Drawing L4 – 44-Pin Pocketed Ceramic Leaded Chip Carrier (CLDCC) – CERQUAD (Package Type L)



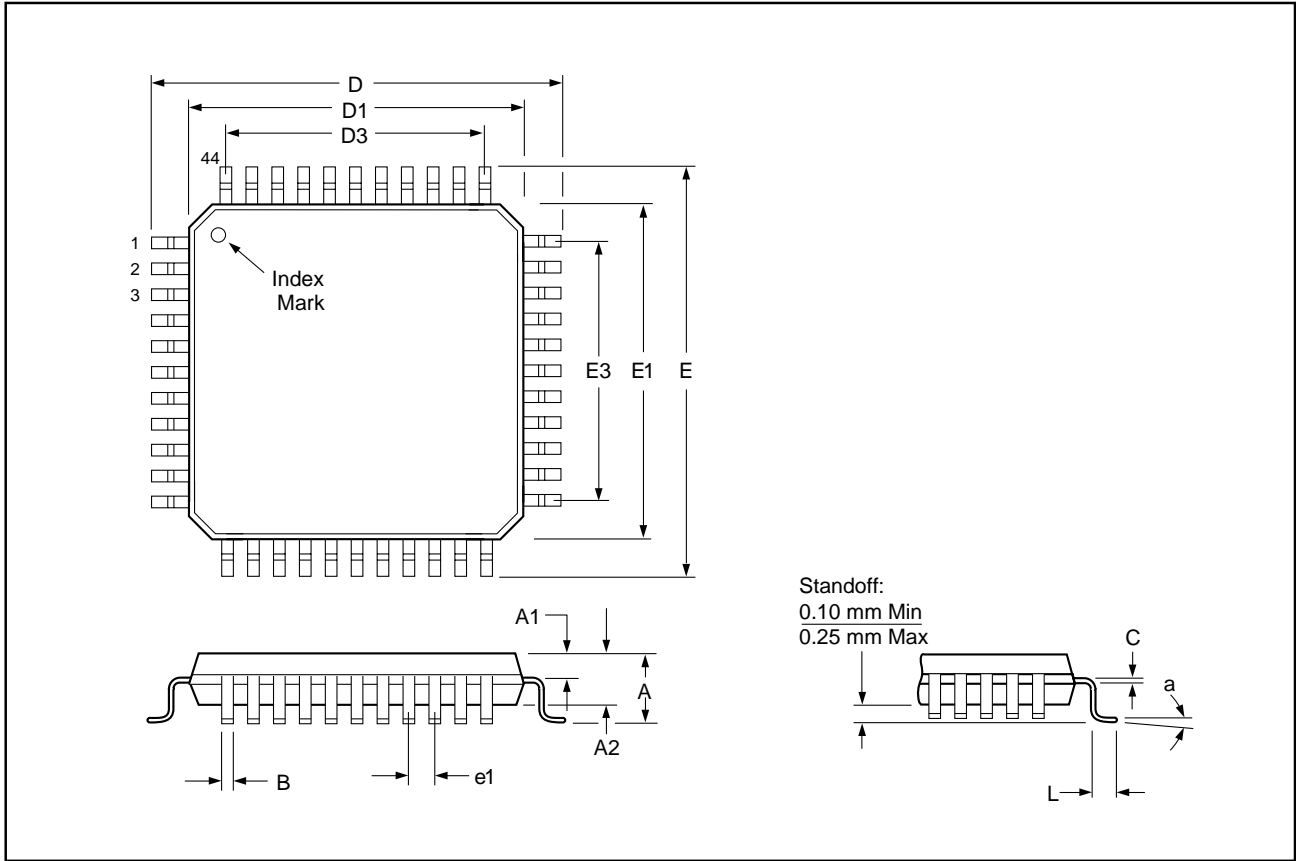
## Family: Ceramic Leaded Chip Carrier – CERQUAD

Symbol	Millimeters			Inches		
	Min	Max	Notes	Min	Max	Notes
A	3.94	4.57		0.155	0.180	
A1	2.29	2.92		0.090	0.115	
A2	3.05	3.68		0.120	0.145	
B	0.43	0.53		0.017	0.021	
B1	0.66	0.81		0.026	0.032	
C	0.15	0.25		0.006	0.010	
D	17.40	17.65		0.685	0.695	
D1	16.31	16.66		0.642	0.656	
D2	14.73	16.26		0.580	0.640	
D3	12.70		Reference	0.500		Reference
E	17.40	17.65		0.685	0.695	
E1	16.31	16.66		0.642	0.656	
E2	14.73	16.26		0.580	0.640	
E3	12.70		Reference	0.500		Reference
e1	1.27		Reference	0.050		Reference
N	44			44		

030195R8



Drawing M1 – 44-Pin Plastic Quad Flatpack (PQFP) (Package Type M)



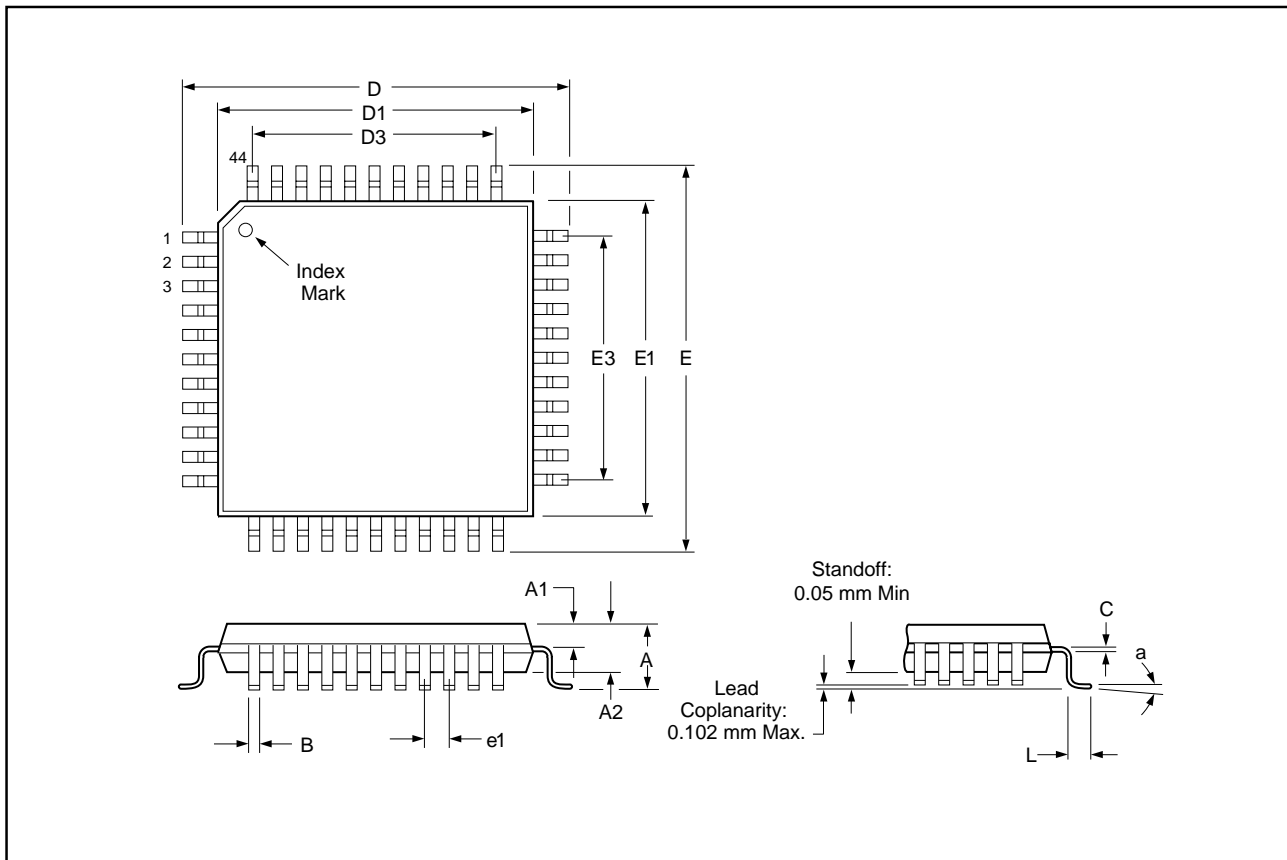
Family: Plastic Quad Flatpack (PQFP)

Symbol	Millimeters			Inches		
	Min	Max	Notes	Min	Max	Notes
$\alpha$	0°	7°		0°	7°	
A	–	2.35		–	0.092	
A1	1.075		Reference	0.042		Reference
A2	1.95	2.10		0.077	0.083	
B	0.30	0.45		0.012	0.018	
C	0.13	0.23		0.005	0.009	
D	13.20			0.520		
D1	10.00			0.394		
D3	8.00		Reference	0.315		Reference
E	13.20			0.520		
E1	10.00			0.394		
E3	8.00		Reference	0.315		Reference
e1	0.80		Reference	0.031		Reference
L	0.73	1.03		0.029	0.040	
N	44			44		

030195R4



Drawing U1 – 44-Pin Plastic Thin Quad Flatpack (TQFP) (Package Type U)



Family: Plastic Thin Quad Flatpack (TQFP)

Symbol	Millimeters			Inches		
	Min	Max	Notes	Min	Max	Notes
$\alpha$	0°	8°		0°	8°	
A	–	1.60		–	0.063	
A1	0.54	0.74		0.021	0.029	
A2	1.15	1.55		0.045	0.061	
B	0.35		Reference	0.014		Reference
C	0.09	0.20		0.004	0.008	
D	15.75	16.25		0.620	0.640	
D1	13.90	14.10		0.547	0.555	
D3	10.00		Reference	0.394		Reference
E	15.75	16.25		0.620	0.640	
E1	13.90	14.10		0.547	0.555	
E3	10.00		Reference	0.394		Reference
e1	1.00		Reference	0.039		Reference
L	0.35	0.65		0.014	0.026	
N	44			44		

030195R4

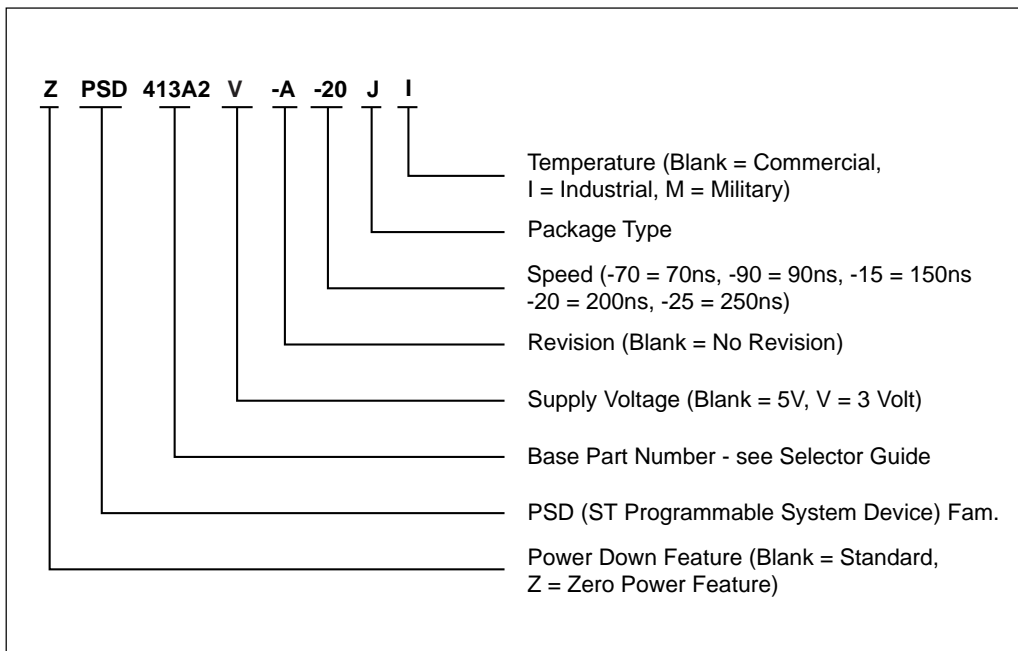


## 22.1 PSD3XX Family – Selector Guide

ST Part #			MCU			PLDs/Decoders				I/O		Memory		Other	
PSD @ 5 V	ZPSD @ 5 V	ZPSD @ 2.7 V	8-Bit Data	16-Bit Data	Interface	Inputs	Product Terms	PLD Outputs	Page Reg.	Ports	Open Drain	EPROM	SRAM	Peripheral Mode	Security
PSD311R	ZPSD311R		X		STD	14	40	11		19	X	256Kb		X	X
PSD301R	ZPSD301R		X	X	STD	14	40	11		19	X	256Kb		X	X
PSD312R	ZPSD312R		X		STD	18	40	11	X	19	X	512Kb		X	X
PSD302R	ZPSD302R		X	X	STD	18	40	11	X	19	X	512Kb		X	X
PSD313R	ZPSD313R		X		STD	18	40	11	X	19	X	1024Kb		X	X
PSD303R	ZPSD303R		X	X	STD	18	40	11	X	19	X	1024Kb		X	X
PSD311	ZPSD311	ZPSD311V	X		STD	14	40	11		19	X	256Kb	16Kb	X	X
PSD301	ZPSD301	ZPSD301V	X	X	STD	14	40	11		19	X	256Kb	16Kb	X	X
PSD312	ZPSD312	ZPSD312V	X		STD	18	40	11	X	19	X	512Kb	16Kb	X	X
PSD302	ZPSD302	ZPSD302V	X	X	STD	18	40	11	X	19	X	512Kb	16Kb	X	X
PSD313	ZPSD313	ZPSD313V	X		STD	18	40	11	X	19	X	1024Kb	16Kb	X	X
PSD303	ZPSD303	ZPSD303V	X	X	STD	18	40	11	X	19	X	1024Kb	16Kb	X	X

**PSD3XX**  
**Ordering**  
**Information**  
 (cont.)

### 22.2 Part Number Construction



### 22.3 Ordering Information

<i>Part Number</i>	<i>Speed (ns)</i>	<i>Package Type</i>	<i>Operating Temperature Range</i>
PSD301-B-70J	70	44 Pin PLDCC	Comm'l
PSD301-B-70L	70	44 Pin CLDCC	Comm'l
PSD301-B-70M	70	44 Pin PQFP	Comm'l
PSD301-B-70U	70	44 Pin TQFP	Comm'l
PSD301-B-90JI	90	44 Pin PLDCC	Industrial
PSD301-B-90LI	90	44 Pin CLDCC	Industrial
PSD301-B-90MI	90	44 Pin PQFP	Industrial
PSD301-B-90UI	90	44 Pin TQFP	Industrial
PSD301-B-15J	150	44 Pin PLDCC	Comm'l
PSD301-B-15L	150	44 Pin CLDCC	Comm'l
PSD301-B-15M	150	44 Pin PQFP	Comm'l
PSD301-B-15U	150	44 Pin TQFP	Comm'l
PSD301R-B-70J	70	44 Pin PLDCC	Comm'l
PSD301R-B-90JI	90	44 Pin PLDCC	Industrial
PSD301R-B-15J	150	44 Pin PLDCC	Comm'l

**PSD3XX**  
**Ordering**  
**Information**  
 (cont.)

**Ordering Information**

<i>Part Number</i>	<i>Speed (ns)</i>	<i>Package Type</i>	<i>Operating Temperature Range</i>
PSD302-B-70J	70	44 Pin PLDCC	Comm'l
PSD302-B-70L	70	44 Pin CLDCC	Comm'l
PSD302-B-70M	70	44 Pin PQFP	Comm'l
PSD302-B-70U	70	44 Pin TQFP	Comm'l
PSD302-B-90JI	90	44 Pin PLDCC	Industrial
PSD302-B-90LI	90	44 Pin CLDCC	Industrial
PSD302-B-90MI	90	44 Pin PQFP	Industrial
PSD302-B-90UI	90	44 Pin TQFP	Industrial
PSD302-B-15J	150	44 Pin PLDCC	Comm'l
PSD302-B-15L	150	44 Pin CLDCC	Comm'l
PSD302-B-15M	150	44 Pin PQFP	Comm'l
PSD302-B-15U	150	44 Pin TQFP	Comm'l
PSD302R-B-70J	70	44 Pin PLDCC	Comm'l
PSD302R-B-90JI	90	44 Pin PLDCC	Industrial
PSD302R-B-15J	150	44 Pin PLDCC	Comm'l
PSD303-B-70J	70	44 Pin PLDCC	Comm'l
PSD303-B-70L	70	44 Pin CLDCC	Comm'l
PSD303-B-70M	70	44 Pin PQFP	Comm'l
PSD303-B-70U	70	44 Pin TQFP	Comm'l
PSD303-B-90JI	90	44 Pin PLDCC	Industrial
PSD303-B-90LI	90	44 Pin CLDCC	Industrial
PSD303-B-90MI	90	44 Pin PQFP	Industrial
PSD303-B-90UI	90	44 Pin TQFP	Industrial
PSD303-B-15J	150	44 Pin PLDCC	Comm'l
PSD303-B-15L	150	44 Pin CLDCC	Comm'l
PSD303-B-15M	150	44 Pin PQFP	Comm'l
PSD303-B-15U	150	44 Pin TQFP	Comm'l
PSD303R-B-70J	70	44 Pin PLDCC	Comm'l
PSD303R-B-90JI	90	44 Pin PLDCC	Industrial
PSD303R-B-15J	150	44 Pin PLDCC	Comm'l
PSD311-B-70J	70	44 Pin PLDCC	Comm'l
PSD311-B-70L	70	44 Pin CLDCC	Comm'l
PSD311-B-70M	70	44 Pin PQFP	Comm'l
PSD311-B-70U	70	44 Pin TQFP	Comm'l
PSD311-B-90JI	90	44 Pin PLDCC	Industrial
PSD311-B-90LI	90	44 Pin CLDCC	Industrial
PSD311-B-90MI	90	44 Pin PQFP	Industrial
PSD311-B-90UI	90	44 Pin TQFP	Industrial
PSD311-B-15J	150	44 Pin PLDCC	Comm'l
PSD311-B-15L	150	44 Pin CLDCC	Comm'l
PSD311-B-15M	150	44 Pin PQFP	Comm'l
PSD311-B-15U	150	44 Pin TQFP	Comm'l
PSD311R-B-70J	70	44 Pin PLDCC	Comm'l
PSD311R-B-90JI	90	44 Pin PLDCC	Industrial
PSD311R-B-15J	150	44 Pin PLDCC	Comm'l

**PSD3XX**  
**Ordering**  
**Information**  
 (cont.)

**Ordering Information**

<i>Part Number</i>	<i>Speed (ns)</i>	<i>Package Type</i>	<i>Operating Temperature Range</i>
PSD312-B-70J	70	44 Pin PLDCC	Comm'l
PSD312-B-70L	70	44 Pin CLDCC	Comm'l
PSD312-B-70M	70	44 Pin PQFP	Comm'l
PSD312-B-70U	70	44 Pin TQFP	Comm'l
PSD312-B-90JI	90	44 Pin PLDCC	Industrial
PSD312-B-90LI	90	44 Pin CLDCC	Industrial
PSD312-B-90MI	90	44 Pin PQFP	Industrial
PSD312-B-90UI	90	44 Pin TQFP	Industrial
PSD312-B-15J	150	44 Pin PLDCC	Comm'l
PSD312-B-15L	150	44 Pin CLDCC	Comm'l
PSD312-B-15M	150	44 Pin PQFP	Comm'l
PSD312-B-15U	150	44 Pin TQFP	Comm'l
PSD312R-B-70J	70	44 Pin PLDCC	Comm'l
PSD312R-B-90JI	90	44 Pin PLDCC	Industrial
PSD312R-B-15J	150	44 Pin PLDCC	Comm'l
PSD313-B-70J	70	44 Pin PLDCC	Comm'l
PSD313-B-70L	70	44 Pin CLDCC	Comm'l
PSD313-B-70M	70	44 Pin PQFP	Comm'l
PSD313-B-70U	70	44 Pin TQFP	Comm'l
PSD313-B-90JI	90	44 Pin PLDCC	Industrial
PSD313-B-90LI	90	44 Pin CLDCC	Industrial
PSD313-B-90MI	90	44 Pin PQFP	Industrial
PSD313-B-90UI	90	44 Pin TQFP	Industrial
PSD313-B-15J	150	44 Pin PLDCC	Comm'l
PSD313-B-15L	150	44 Pin CLDCC	Comm'l
PSD313-B-15M	150	44 Pin PQFP	Comm'l
PSD313-B-15U	150	44 Pin TQFP	Comm'l
PSD313R-B-70J	70	44 Pin PLDCC	Comm'l
PSD313R-B-90JI	90	44 Pin PLDCC	Industrial
PSD313R-B-15J	150	44 Pin PLDCC	Comm'l

**PSD3XX**  
**Ordering**  
**Information**  
 (cont.)

**Ordering Information**

<i>Part Number</i>	<i>Speed (ns)</i>	<i>Package Type</i>	<i>Operating Temperature Range</i>
ZPSD301-B-70J	70	44 Pin PLDCC	Comm'l
ZPSD301-B-70L	70	44 Pin CLDCC	Comm'l
ZPSD301-B-70M	70	44 Pin PQFP	Comm'l
ZPSD301-B-70U	70	44 Pin TQFP	Comm'l
ZPSD301-B-90JI	90	44 Pin PLDCC	Industrial
ZPSD301-B-90LI	90	44 Pin CLDCC	Industrial
ZPSD301-B-90MI	90	44 Pin PQFP	Industrial
ZPSD301-B-90UI	90	44 Pin TQFP	Industrial
ZPSD301-B-15J	150	44 Pin PLDCC	Comm'l
ZPSD301-B-15L	150	44 Pin CLDCC	Comm'l
ZPSD301-B-15M	150	44 Pin PQFP	Comm'l
ZPSD301-B-15U	150	44 Pin TQFP	Comm'l
ZPSD301R-B-70J	70	44 Pin PLDCC	Comm'l
ZPSD301R-B-90JI	90	44 Pin PLDCC	Industrial
ZPSD301R-B-15J	150	44 Pin PLDCC	Comm'l
ZPSD301V-B-15J	150	44 Pin PLDCC	Comm'l
ZPSD301V-B-15L	150	44 Pin CLDCC	Comm'l
ZPSD301V-B-15U	150	44 Pin TQFP	Comm'l
ZPSD301V-B-20J	200	44 Pin PLDCC	Comm'l
ZPSD301V-B-20JI	200	44 Pin PLDCC	Industrial
ZPSD301V-B-20L	200	44 Pin CLDCC	Comm'l
ZPSD301V-B-20M	200	44 Pin PQFP	Comm'l
ZPSD301V-B-20MI	200	44 Pin PQFP	Industrial
ZPSD301V-B-20U	200	44 Pin TQFP	Comm'l
ZPSD301V-B-20UI	200	44 Pin TQFP	Industrial
ZPSD301V-B-25J	250	44 Pin PLDCC	Comm'l
ZPSD301V-B-25L	250	44 Pin CLDCC	Comm'l
ZPSD301V-B-25M	250	44 Pin PQFP	Comm'l
ZPSD301V-B-25U	250	44 Pin TQFP	Comm'l
ZPSD302-B-70J	70	44 Pin PLDCC	Comm'l
ZPSD302-B-70L	70	44 Pin CLDCC	Comm'l
ZPSD302-B-70M	70	44 Pin PQFP	Comm'l
ZPSD302-B-70U	70	44 Pin TQFP	Comm'l
ZPSD302-B-90JI	90	44 Pin PLDCC	Industrial
ZPSD302-B-90LI	90	44 Pin CLDCC	Industrial
ZPSD302-B-90MI	90	44 Pin PQFP	Industrial
ZPSD302-B-90UI	90	44 Pin TQFP	Industrial
ZPSD302-B-15J	150	44 Pin PLDCC	Comm'l
ZPSD302-B-15L	150	44 Pin CLDCC	Comm'l
ZPSD302-B-15M	150	44 Pin PQFP	Comm'l
ZPSD302-B-15U	150	44 Pin TQFP	Comm'l
ZPSD302R-B-70J	70	44 Pin PLDCC	Comm'l
ZPSD302R-B-90JI	90	44 Pin PLDCC	Industrial
ZPSD302R-B-15J	150	44 Pin PLDCC	Comm'l

**PSD3XX**  
**Ordering**  
**Information**  
 (cont.)

**Ordering Information**

<i>Part Number</i>	<i>Speed (ns)</i>	<i>Package Type</i>	<i>Operating Temperature Range</i>
ZPSD302V-B-20J	200	44 Pin PLDCC	Comm'l
ZPSD302V-B-20JI	200	44 Pin PLDCC	Industrial
ZPSD302V-B-20L	200	44 Pin CLDCC	Comm'l
ZPSD302V-B-20M	200	44 Pin PQFP	Comm'l
ZPSD302V-B-20MI	200	44 Pin PQFP	Industrial
ZPSD302V-B-20U	200	44 Pin TQFP	Comm'l
ZPSD302V-B-20UI	200	44 Pin TQFP	Industrial
ZPSD302V-B-25J	250	44 Pin PLDCC	Comm'l
ZPSD302V-B-25L	250	44 Pin CLDCC	Comm'l
ZPSD302V-B-25M	250	44 Pin PQFP	Comm'l
ZPSD302V-B-25U	250	44 Pin TQFP	Comm'l
ZPSD303-B-70J	70	44 Pin PLDCC	Comm'l
ZPSD303-B-70L	70	44 Pin CLDCC	Comm'l
ZPSD303-B-70M	70	44 Pin PQFP	Comm'l
ZPSD303-B-70U	70	44 Pin TQFP	Comm'l
ZPSD303-B-90JI	90	44 Pin PLDCC	Industrial
ZPSD303-B-90LI	90	44 Pin CLDCC	Industrial
ZPSD303-B-90MI	90	44 Pin PQFP	Industrial
ZPSD303-B-90UI	90	44 Pin TQFP	Industrial
ZPSD303-B-15J	150	44 Pin PLDCC	Comm'l
ZPSD303-B-15L	150	44 Pin CLDCC	Comm'l
ZPSD303-B-15M	150	44 Pin PQFP	Comm'l
ZPSD303-B-15U	150	44 Pin TQFP	Comm'l
ZPSD303R-B-70J	70	44 Pin PLDCC	Comm'l
ZPSD303R-B-90JI	90	44 Pin PLDCC	Industrial
ZPSD303R-B-15J	150	44 Pin PLDCC	Comm'l
ZPSD303V-B-20J	200	44 Pin PLDCC	Comm'l
ZPSD303V-B-20JI	200	44 Pin PLDCC	Industrial
ZPSD303V-B-20L	200	44 Pin CLDCC	Comm'l
ZPSD303V-B-20M	200	44 Pin PQFP	Comm'l
ZPSD303V-B-20MI	200	44 Pin PQFP	Industrial
ZPSD303V-B-20U	200	44 Pin TQFP	Comm'l
ZPSD303V-B-20UI	200	44 Pin TQFP	Industrial
ZPSD303V-B-25J	250	44 Pin PLDCC	Comm'l
ZPSD303V-B-25L	250	44 Pin CLDCC	Comm'l
ZPSD303V-B-25M	250	44 Pin PQFP	Comm'l
ZPSD303V-B-25U	250	44 Pin TQFP	Comm'l





**PSD3XX**  
**Ordering**  
**Information**  
 (cont.)

**Ordering Information**

<i>Part Number</i>	<i>Speed (ns)</i>	<i>Package Type</i>	<i>Operating Temperature Range</i>
ZPSD311-B-70J	70	44 Pin PLDCC	Comm'l
ZPSD311-B-70L	70	44 Pin CLDCC	Comm'l
ZPSD311-B-70M	70	44 Pin PQFP	Comm'l
ZPSD311-B-70U	70	44 Pin TQFP	Comm'l
ZPSD311-B-90JI	90	44 Pin PLDCC	Industrial
ZPSD311-B-90LI	90	44 Pin CLDCC	Industrial
ZPSD311-B-90MI	90	44 Pin PQFP	Industrial
ZPSD311-B-90UI	90	44 Pin TQFP	Industrial
ZPSD311-B-15J	150	44 Pin PLDCC	Comm'l
ZPSD311-B-15L	150	44 Pin CLDCC	Comm'l
ZPSD311-B-15M	150	44 Pin PQFP	Comm'l
ZPSD311-B-15U	150	44 Pin TQFP	Comm'l
ZPSD311R-B-70J	70	44 Pin PLDCC	Comm'l
ZPSD311R-B-70M	70	44 Pin PQFP	Comm'l
ZPSD311R-B-90JI	90	44 Pin PLDCC	Industrial
ZPSD311R-B-90MI	90	44 Pin PQFP	Industrial
ZPSD311R-B-15J	150	44 Pin PLDCC	Comm'l
ZPSD311R-B-15M	150	44 Pin PQFP	Comm'l
ZPSD311V-B-15J	150	44 Pin PLDCC	Comm'l
ZPSD311V-B-15L	150	44 Pin CLDCC	Comm'l
ZPSD311V-B-15M	150	44 Pin PQFP	Comm'l
ZPSD311V-B-15U	150	44 Pin TQFP	Comm'l
ZPSD311V-B-20J	200	44 Pin PLDCC	Comm'l
ZPSD311V-B-20JI	200	44 Pin PLDCC	Industrial
ZPSD311V-B-20L	200	44 Pin CLDCC	Comm'l
ZPSD311V-B-20M	200	44 Pin PQFP	Comm'l
ZPSD311V-B-20MI	200	44 Pin PQFP	Industrial
ZPSD311V-B-20U	200	44 Pin TQFP	Comm'l
ZPSD311V-B-20UI	200	44 Pin TQFP	Industrial
ZPSD311V-B-25J	250	44 Pin PLDCC	Comm'l
ZPSD311V-B-25L	250	44 Pin CLDCC	Comm'l
ZPSD311V-B-25M	250	44 Pin PQFP	Comm'l
ZPSD311V-B-25U	250	44 Pin TQFP	Comm'l

**PSD3XX**  
**Ordering**  
**Information**  
 (cont.)

**Ordering Information**

<i>Part Number</i>	<i>Speed (ns)</i>	<i>Package Type</i>	<i>Operating Temperature Range</i>
ZPSD312-B-70J	70	44 Pin PLDCC	Comm'l
ZPSD312-B-70L	70	44 Pin CLDCC	Comm'l
ZPSD312-B-70M	70	44 Pin PQFP	Comm'l
ZPSD312-B-70U	70	44 Pin TQFP	Comm'l
ZPSD312-B-90JI	90	44 Pin PLDCC	Industrial
ZPSD312-B-90LI	90	44 Pin CLDCC	Industrial
ZPSD312-B-90MI	90	44 Pin PQFP	Industrial
ZPSD312-B-90UI	90	44 Pin TQFP	Industrial
ZPSD312-B-15J	150	44 Pin PLDCC	Comm'l
ZPSD312-B-15L	150	44 Pin CLDCC	Comm'l
ZPSD312-B-15M	150	44 Pin PQFP	Comm'l
ZPSD312-B-15U	150	44 Pin TQFP	Comm'l
ZPSD312R-B-70J	70	44 Pin PLDCC	Comm'l
ZPSD312R-B-70M	70	44 Pin PQFP	Comm'l
ZPSD312R-B-90JI	90	44 Pin PLDCC	Industrial
ZPSD312R-B-90MI	90	44 Pin PQFP	Industrial
ZPSD312R-B-15J	150	44 Pin PLDCC	Comm'l
ZPSD312R-B-15M	150	44 Pin PQFP	Comm'l
ZPSD312V-B-20J	200	44 Pin PLDCC	Comm'l
ZPSD312V-B-20JI	200	44 Pin PLDCC	Industrial
ZPSD312V-B-20L	200	44 Pin CLDCC	Comm'l
ZPSD312V-B-20M	200	44 Pin PQFP	Comm'l
ZPSD312V-B-20MI	200	44 Pin PQFP	Industrial
ZPSD312V-B-20U	200	44 Pin TQFP	Comm'l
ZPSD312V-B-20UI	200	44 Pin TQFP	Industrial
ZPSD312V-B-25J	250	44 Pin PLDCC	Comm'l
ZPSD312V-B-25L	250	44 Pin CLDCC	Comm'l
ZPSD312V-B-25M	250	44 Pin PQFP	Comm'l
ZPSD312V-B-25U	250	44 Pin TQFP	Comm'l
ZPSD313-B-70J	70	44 Pin PLDCC	Comm'l
ZPSD313-B-70L	70	44 Pin CLDCC	Comm'l
ZPSD313-B-70M	70	44 Pin PQFP	Comm'l
ZPSD313-B-70U	70	44 Pin TQFP	Comm'l
ZPSD313-B-90JI	90	44 Pin PLDCC	Industrial
ZPSD313-B-90LI	90	44 Pin CLDCC	Industrial
ZPSD313-B-90MI	90	44 Pin PQFP	Industrial
ZPSD313-B-90UI	90	44 Pin TQFP	Industrial
ZPSD313-B-15J	150	44 Pin PLDCC	Comm'l
ZPSD313-B-15L	150	44 Pin CLDCC	Comm'l
ZPSD313-B-15M	150	44 Pin PQFP	Comm'l
ZPSD313-B-15U	150	44 Pin TQFP	Comm'l

**PSD3XX**  
**Ordering**  
**Information**  
 (cont.)

**Ordering Information**

<i>Part Number</i>	<i>Speed (ns)</i>	<i>Package Type</i>	<i>Operating Temperature Range</i>
ZPSD313R-B-70J	70	44 Pin PLDCC	Comm'l
ZPSD313R-B-70M	70	44 Pin PQFP	Comm'l
ZPSD313R-B-90JI	90	44 Pin PLDCC	Industrial
ZPSD313R-B-90MI	90	44 Pin PQFP	Industrial
ZPSD313R-B-15J	150	44 Pin PLDCC	Comm'l
ZPSD313R-B-15M	150	44 Pin PQFP	Comm'l
ZPSD313V-B-20J	200	44 Pin PLDCC	Comm'l
ZPSD313V-B-20JI	200	44 Pin PLDCC	Industrial
ZPSD313V-B-20L	200	44 Pin CLDCC	Comm'l
ZPSD313V-B-20M	200	44 Pin PQFP	Comm'l
ZPSD313V-B-20MI	200	44 Pin PQFP	Industrial
ZPSD313V-B-20U	200	44 Pin TQFP	Comm'l
ZPSD313V-B-20UI	200	44 Pin TQFP	Industrial
ZPSD313V-B-25J	250	44 Pin PLDCC	Comm'l
ZPSD313V-B-25L	250	44 Pin CLDCC	Comm'l
ZPSD313V-B-25M	250	44 Pin PQFP	Comm'l
ZPSD313V-B-25U	250	44 Pin TQFP	Comm'l

**23.**  
**Revisions**  
**History**

<i>Date</i>	<i>Parts Affected</i>	<i>Data Sheet Changes</i>
May, 1995	PSD3XX	Initial Release
May, 1998	ZPSD3XX	SRAM-less (R suffix) version added. PQFP package added.
May, 1998	PSD3XX	PQFP package added, Specifications updated, PSD3XXL discontinued, Some speed grades eliminated.
February, 1999	PSD3XXR, ZPSD3XXR	Combined Data Sheets Updated Specifications

## PSD3XX, ZPSD3XX, ZPSD3XXV, PSD3XXR, ZPSD3XXR, ZPSD3XXRV

---

### REVISION HISTORY

**Table 1. Document Revision History**

Date	Rev.	Description of Revision
May-1995	1.0	Documents written in the WSI format. Initial release
May-1998	1.1	ZPSD3XX SRAM-less (R suffix) version added. PQFP package added. PSD3XX PQFP package added, Specifications updated, PSD3XXL discontinued, Some speed grades eliminated. February, 1999 PSD3XXR, ZPSD3XXR Combined Data Sheets Updated Specifications
Feb-1999	1.2	PSD3XX ZPSD3XX ZPSD3XXV, PSD3XXR ZPSD3XXR ZPSD3XXRV Combined Data Sheets Updated Specifications
31-Jan-2002	1.3	PSD3XX, ZPSD3XX, ZPSD3XXV, PSD3XXR, ZPSD3XXR, ZPSD3XXRV: Low Cost Field Programmable Microcontroller Peripherals Front page, and back two pages, in ST format, added to the PDF file Any references to Wafer-scale, WSI, EasyFLASH and PSDsoft 2000 updated to ST, ST, Flash+PSD and PSDsoft Express

Information furnished is believed to be accurate and reliable. However, STMicroelectronics assumes no responsibility for the consequences of use of such information nor for any infringement of patents or other rights of third parties which may result from its use. No license is granted by implication or otherwise under any patent or patent rights of STMicroelectronics. Specifications mentioned in this publication are subject to change without notice. This publication supersedes and replaces all information previously supplied. STMicroelectronics products are not authorized for use as critical components in life support devices or systems without express written approval of STMicroelectronics.

The ST logo is registered trademark of STMicroelectronics  
All other names are the property of their respective owners

© 2002 STMicroelectronics - All Rights Reserved

STMicroelectronics group of companies Australia - Brazil - Canada - China - Finland - France - Germany - Hong Kong -  
India - Israel - Italy - Japan - Malaysia - Malta - Morocco - Singapore - Spain - Sweden - Switzerland - United Kingdom - United States.

[www.st.com](http://www.st.com)

