

**SMALLBLOCK™ Products
MOSFET Turn-Off Device
With Integral Gate Clamp**

The MDC1000 series is a silicon turn-off device designed to reduce the turn-off time of a MOSFET or an IGBT. It also clamps the MOSFET gate voltage to a safe level. This device eliminates the use of individual components by integrating them into a single device. The use of the MDC1000 series can reduce system cost and board space, while optimizing the switching performance of the MOSFET. The MOSFET Turn-Off Device is a member of the SMALLBLOCK family.

- Output Voltage Clamped to 12.5 Volts to Protect the MOSFET Gate
- Very Fast Turn-Off Time, 15 Nanoseconds Typical
- Simplifies Circuit Design
- Reduces Board Space
- Three Package Styles: TO-92 for Insertion, SOT-23 and SOT-223 for Surface Mount
- Applications Literature: EB-142; The MOSFET Turn-Off Device, A New Circuit Building Block; AN1078; New Components Simplify Brush DC Motor Drives; AN1087; Speeding up Horizontal Outputs; AN1101; One-Horsepower Off-Line Brushless Permanent Magnet Motor Drive

MDC1000A,BLT1,CT1 EQUIVALENT CIRCUIT

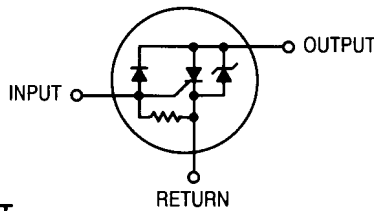
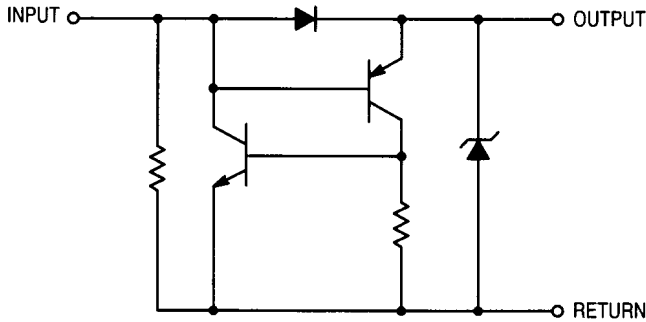

MDC1000A

- 1-Return
- 2-Input
- 3-Output

MDC1000BLT1

- 1-Return
- 2-Output
- 3-Input

MDC1000CT1

- 1-Return
- 2-Input
- 3-Output
- 4-Input

ORDERING INFORMATION

Device	Reel Size	Packaging	Quantity
MDC1000A	—	bulk	1000
MDC1000ARLRM	—	ammo pack	2000
MDC1000BLT1	7"	8 mm embossed tape	3000
MDC1000BLT3	13"		10000
MDC1000CT1	7"	12 mm embossed tape	1000
MDC1000CT3	13"		4000

SMALLBLOCK is a trademark of Motorola Inc.
Thermal Clad is a registered trademark of the Bergquist Company

Preferred devices are Motorola recommended choices for future use and best overall value.

**MDC1000A
MDC1000BLT1
MDC1000CT1**

Motorola preferred devices

**TURN-OFF DEVICE
FOR
POWER MOSFETs**

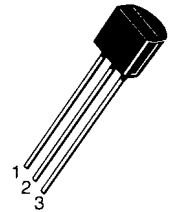

**MDC1000A
CASE 29-04, STYLE 33
TO-226AA (TO-92)**

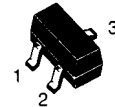

**MDC1000BLT1
CASE 318-07, STYLE 22
TO-236AB (SOT-23)**



**MDC1000CT1
CASE 318E-04, STYLE 6
TO-261AA (SOT-223)**



MAXIMUM RATINGS ($T_A = 25^\circ\text{C}$ unless otherwise specified)

Rating	Symbol	Value	Unit
Input — Continuous	I_{IN}	50	mA
Input — Current Peak (Pulse Width = 20 μs , Duty Cycle $\leq 2\%$)	I_{INM}	500	mA
Thermal Resistance — Junction to Ambient MDC1000A MDC1000BLT1 MDC1000CT1	$R_{\theta JA}$	0.227 0.625 0.227	$^\circ\text{C}/\text{mW}$
Total Power Dissipation @ $T_A = 25^\circ\text{C}$ MDC1000A MDC1000BLT1* MDC1000CT1*	P_D	550 200 550	mW
Derate above 25°C MDC1000A MDC1000BLT1* MDC1000CT1*		1.82 5.7 1.82	$\text{mW}/^\circ\text{C}$
Operating and Storage Temperature Range	T_J, T_{stg}	- 65 to +150	$^\circ\text{C}$
Lead Soldering Temperature**	T_L	260	$^\circ\text{C}$

*Device mounted on an FR-5 printed circuit board 1.0 x 0.75 x 0.062 inches using footprint shown on Page 10.
**Additional information on soldering of the MDC1000BLT1,CT1 surface mount packages is shown on Page 10.

DEVICE MARKING

MDC1000A	MDC1000
MDC1000BLT1	C10
MDC1000CT1	C1000

ELECTRICAL CHARACTERISTICS ($T_A = 25^\circ\text{C}$ unless otherwise noted)

Characteristic	Symbol	Min	Typ	Max	Unit
Input Clamp Voltage [Note 1] ($I_{IN} = 2.0 \text{ mA}$) ($I_{IN} = 50 \text{ mA}$)	V_{in}	9.5 9.5	11 11.2	12 12.5	Vdc
Output Clamp Voltage [Note 2] ($I_{OUT} = 2.0 \text{ mA}$) ($I_{OUT} = 50 \text{ mA}$)	V_{out}	9.0 9.0	10.4 10.8	11.5 12	Vdc
Turn-Off Time (1000 pF, from 9.0 V to 1.0 V) See Figures 1 and 2	t_{off}	—	15	—	ns
Storage Time	t_s	—	60	—	ns
Propagation Delay	t_{prop}	—	5.0	—	ns
Input Capacitance @ 10 Volts, $f = 1.0 \text{ MHz}$	C_{in}	—	5.0	—	pF
Dropout Current [Note 4]	$I_{(sus)}$	50	110	—	μA

- [1] Input pin (+) to return pin(-) with output pin open.
- [2] Input and output pins common(+) to return pin(-).
- [3] MDC1000s should be mounted as close as possible to the MOSFET being controlled to minimize noise difficulties. In particular, the return lead should have as short a run to the MOSFET source lead as possible. Also, Kelvin connections between the MDC1000 return lead and the MOSFET source lead will enhance noise immunity.
- [4] Output Current level below which MTO must fall to insure driver MOSFET will turn back on.

SWITCHING

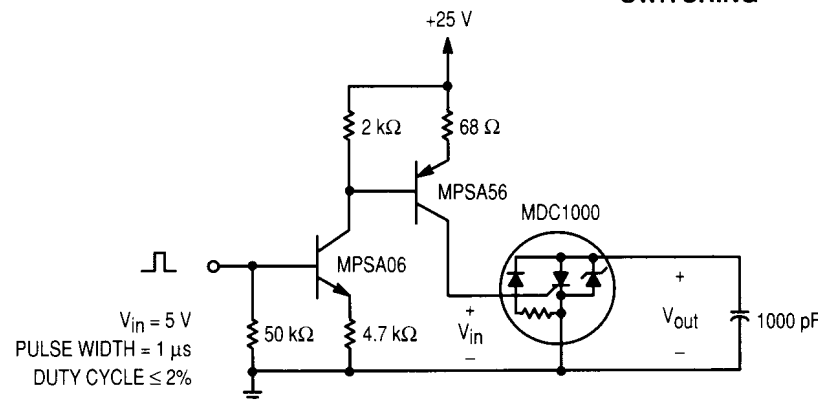

Figure 1. Turn-Off Time Test Circuit

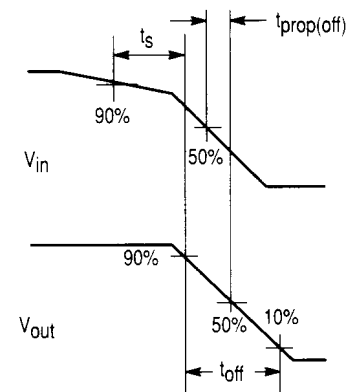

Figure 2. Turn-Off Waveforms

TYPICAL CHARACTERISTICS

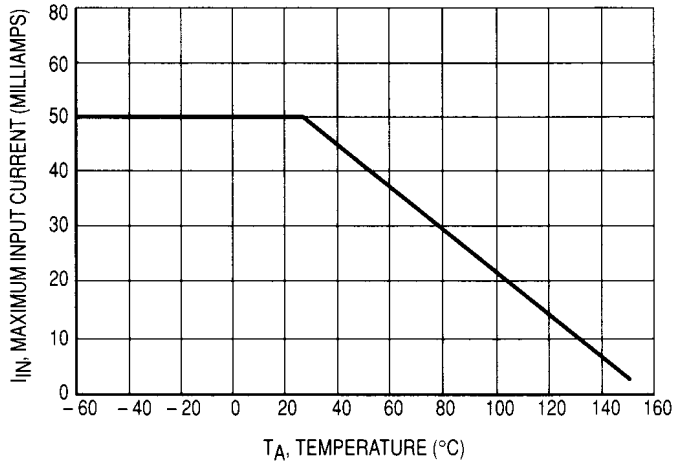

Figure 3. Allowable Input Current versus Ambient Temperature

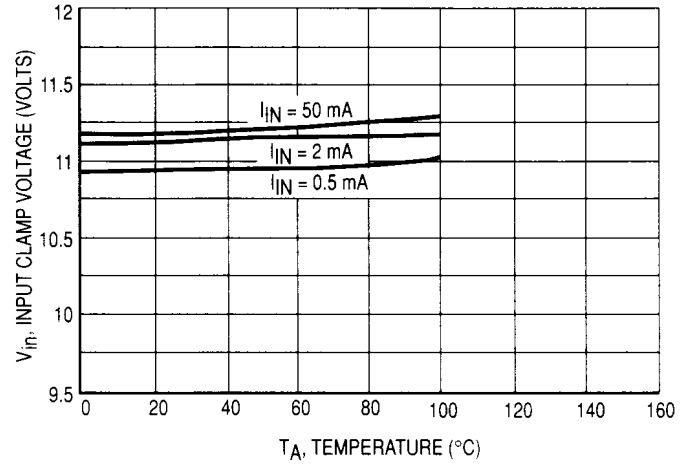

Figure 4. Input Clamp Voltage versus Ambient Temperature

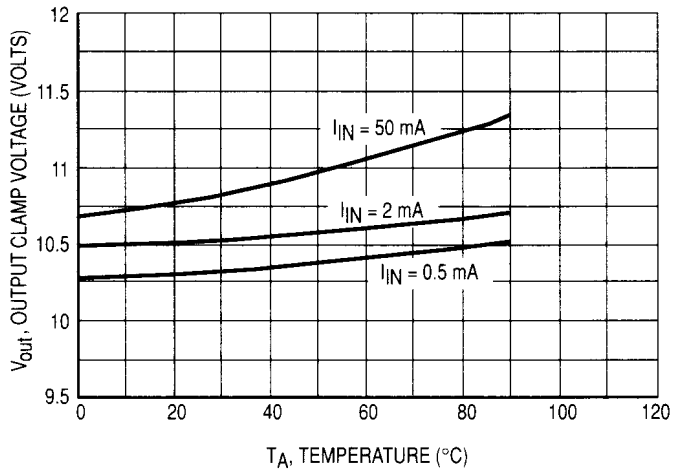

Figure 5. Output Clamp Voltage versus Ambient Temperature

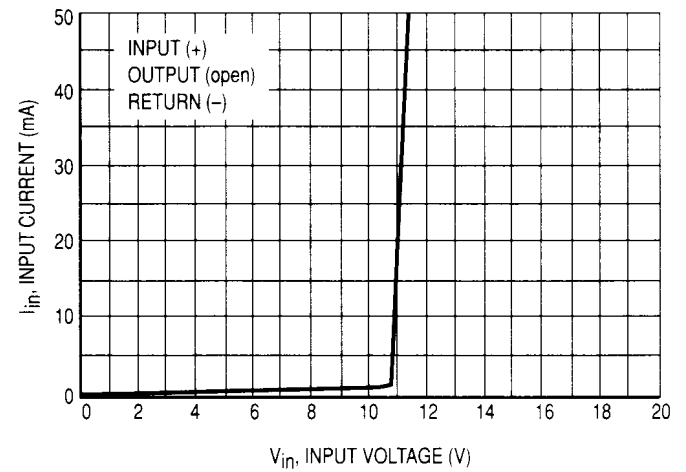

Figure 6. Input Characteristics

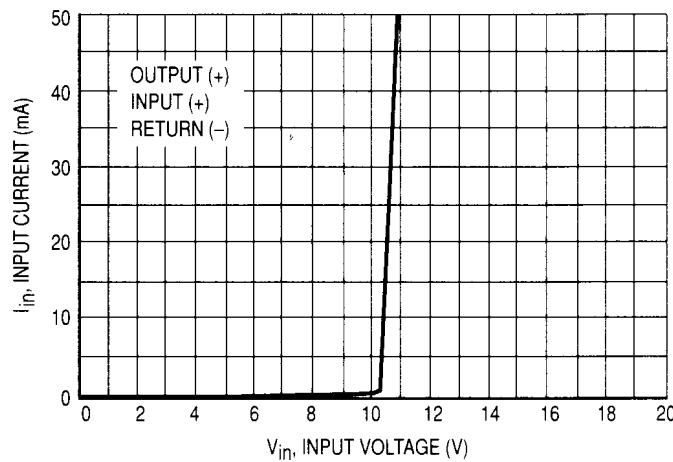

Figure 7. Output Characteristics

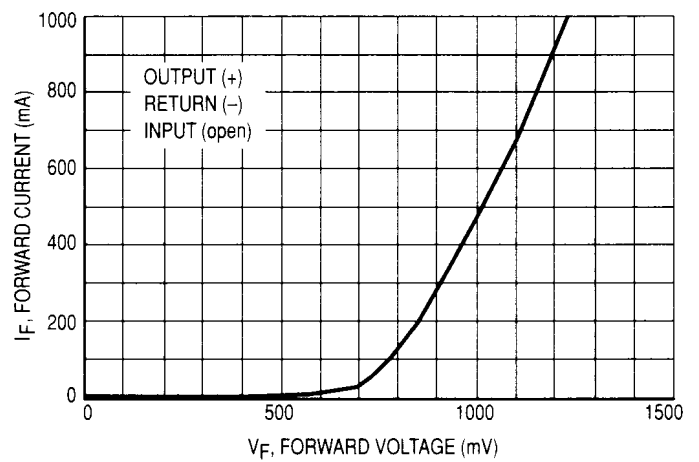

Figure 8. Forward Voltage Drop

TYPICAL CHARACTERISTICS

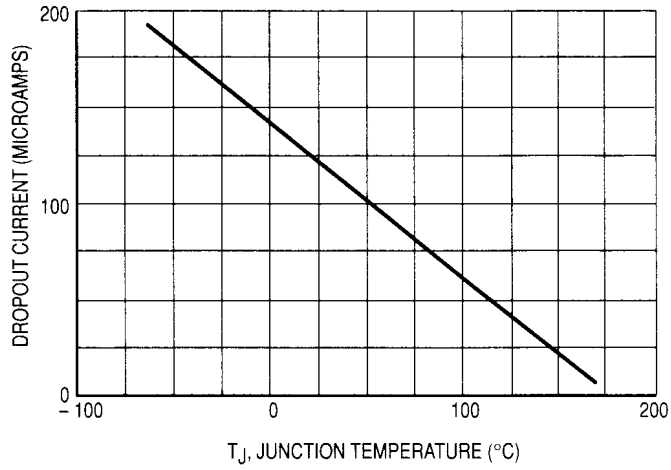

Figure 9. Dropout Current versus Temperature

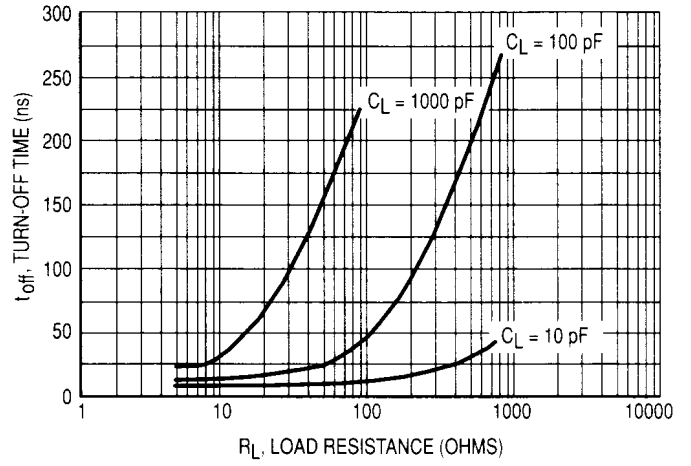

Figure 10. t_{off} versus Load Resistance/Load Capacitance

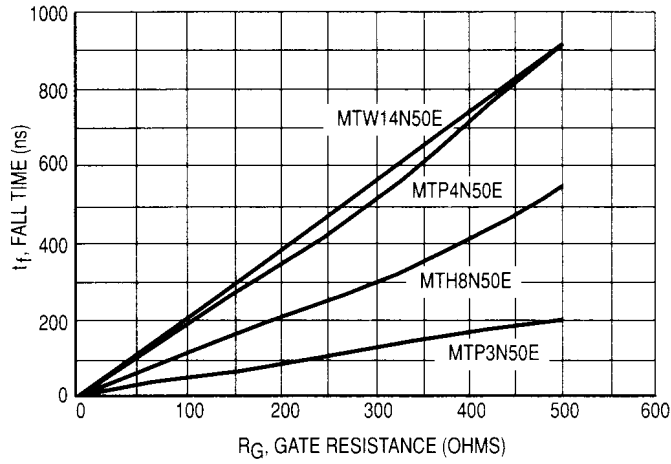

Figure 11. MOSFET Fall Time versus Gate Resistance

OPERATING DESCRIPTION

The MDC1000 series provides an economical and space saving method of turning off a power MOSFET while achieving a level of circuit improvement at the same time. It reduces the component count of an active gate turn-off network for MOSFETs. The device quickly discharges the gate-source and gate-drain capacitances when the input signal is removed and provides protection of the gate-source in the event of an overvoltage condition on the control line.

To turn a MOSFET off, it is necessary to discharge the input capacitance to drive the gate-source voltage to below $V_{GS(th)}$. Turning on a MOSFET is fairly straight-forward, but turning it off frequently calls for some form of active turn-off network to help speed up the turn-off process. Typically, this

has been achieved with a network comprised of several active and passive components. The effect of the turn-off network is to provide a low impedance discharge path for the MOSFET input capacitance and therefore speed up its turn-off.

Instead of a single PNP transistor which is commonly used for the turn-off function, an NPN has been added and is connected to the PNP in the configuration of an SCR. This combination provides the regenerative turn-on action of an SCR, further speeding up the process of discharging the gate of the MOSFET. It also contains an integral 10.4 volt zener diode, providing the MOSFET gate with overvoltage protection. Using the MDC1000 series, a power MOSFET can typically be turned off in tens of nanoseconds.

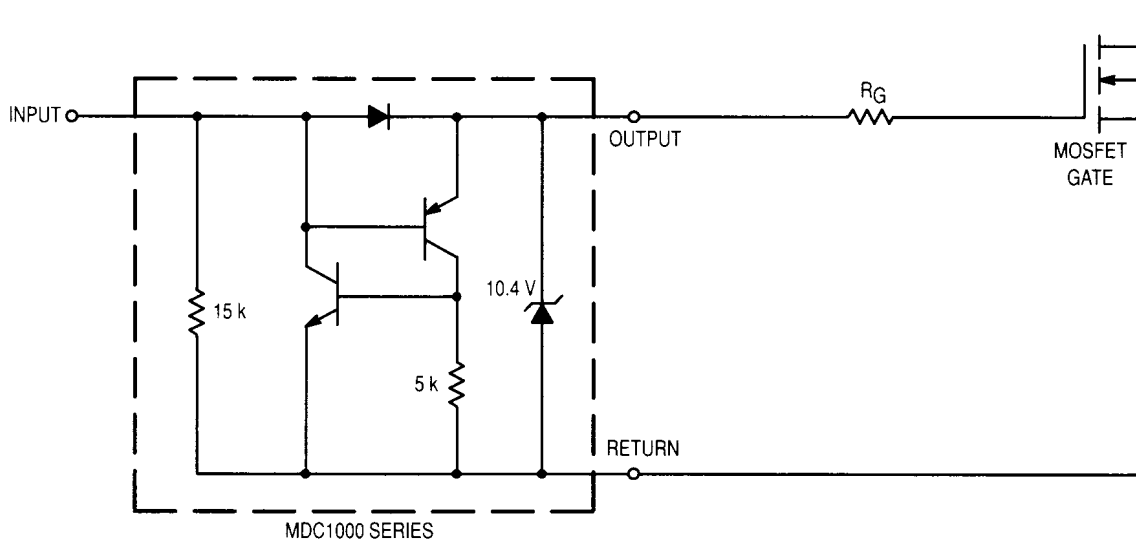

Figure 12. Recommended Gate Drive Circuit

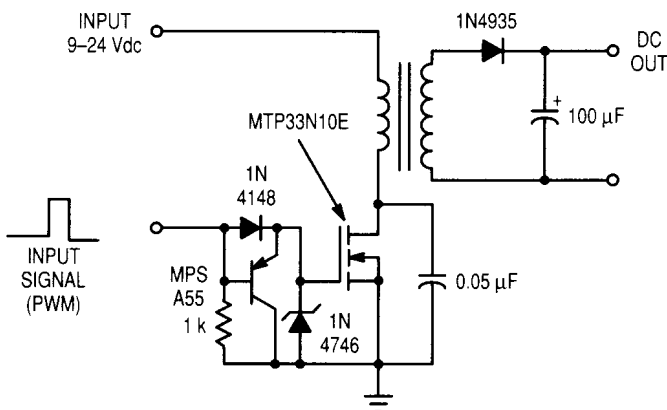

Figure 13a. Utilizing Discrete Components

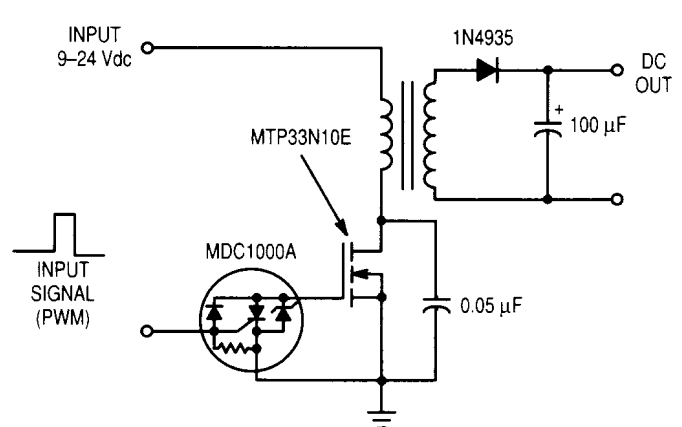

Figure 13b. Utilizing MDC1000A

Figure 13. Active MOSFET Gate Turn-Off Circuit

TYPICAL APPLICATIONS UTILIZING THE MDC1000A

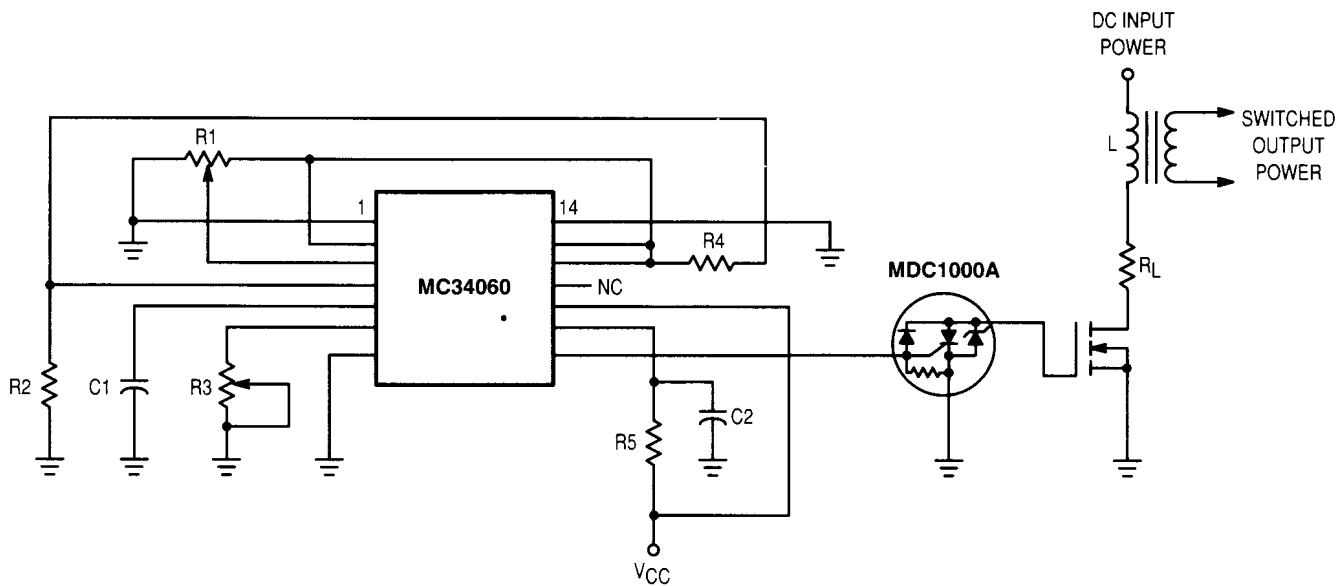

Figure 14. PWM Portion of Switchmode Power Supply for Power MOSFET Gate Control

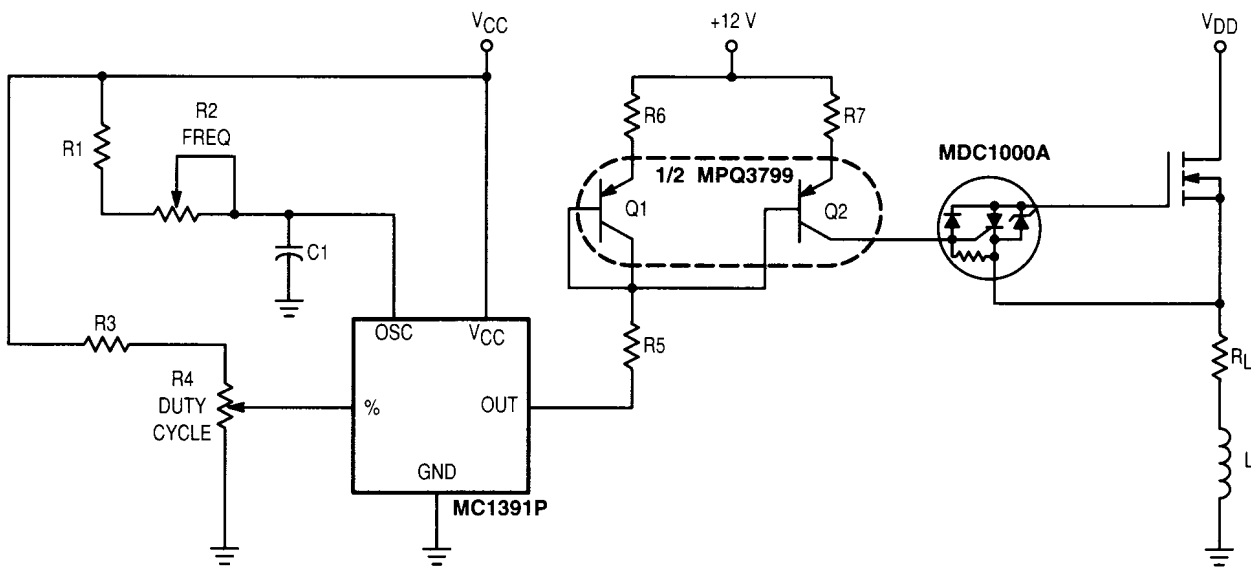

Figure 15. Horizontal Gain Circuit for Power MOSFET Gate Control and PNP Current Mirror for Gate Drive Circuit

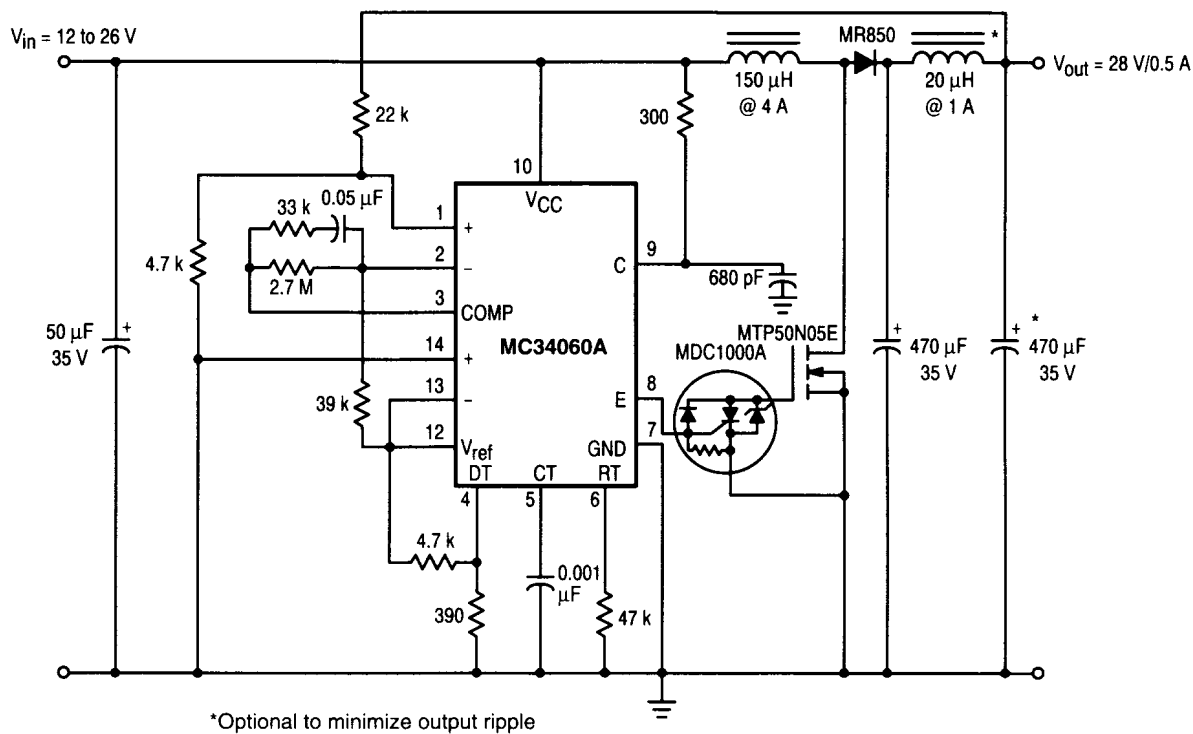

Figure 16. DC-DC Converter

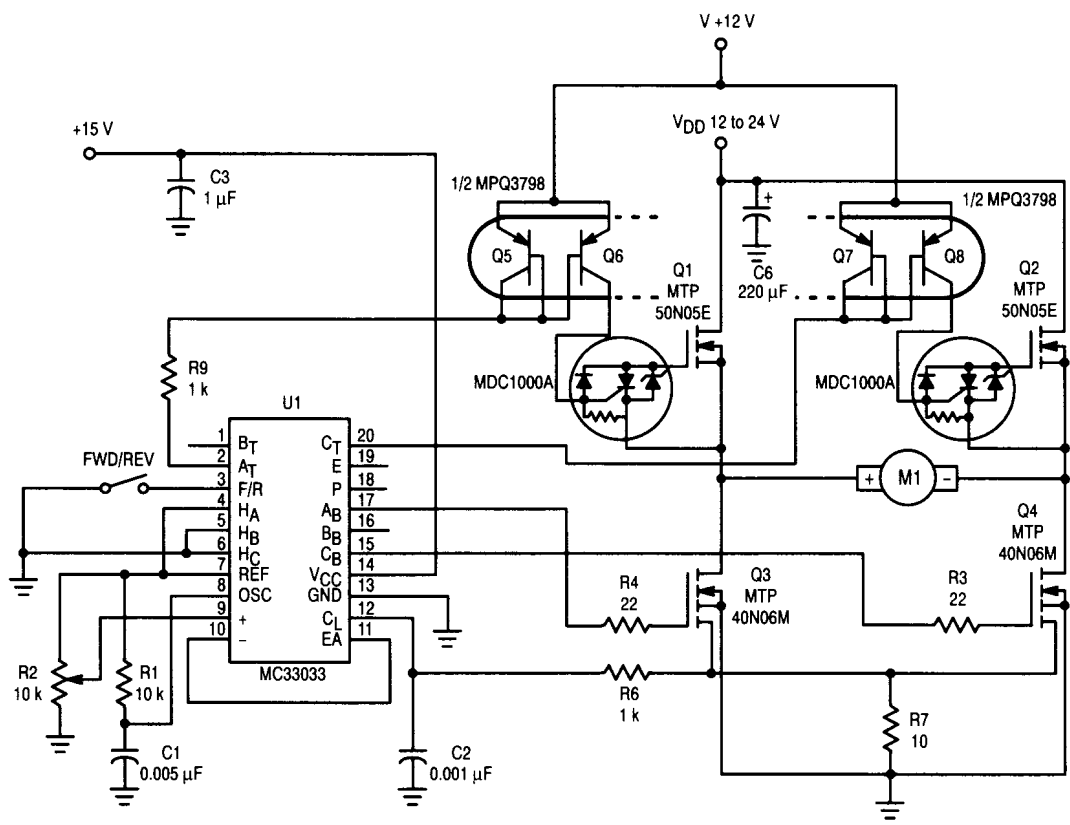

Figure 17. DC Motor Control Utilizing High Side MOSFET Switches

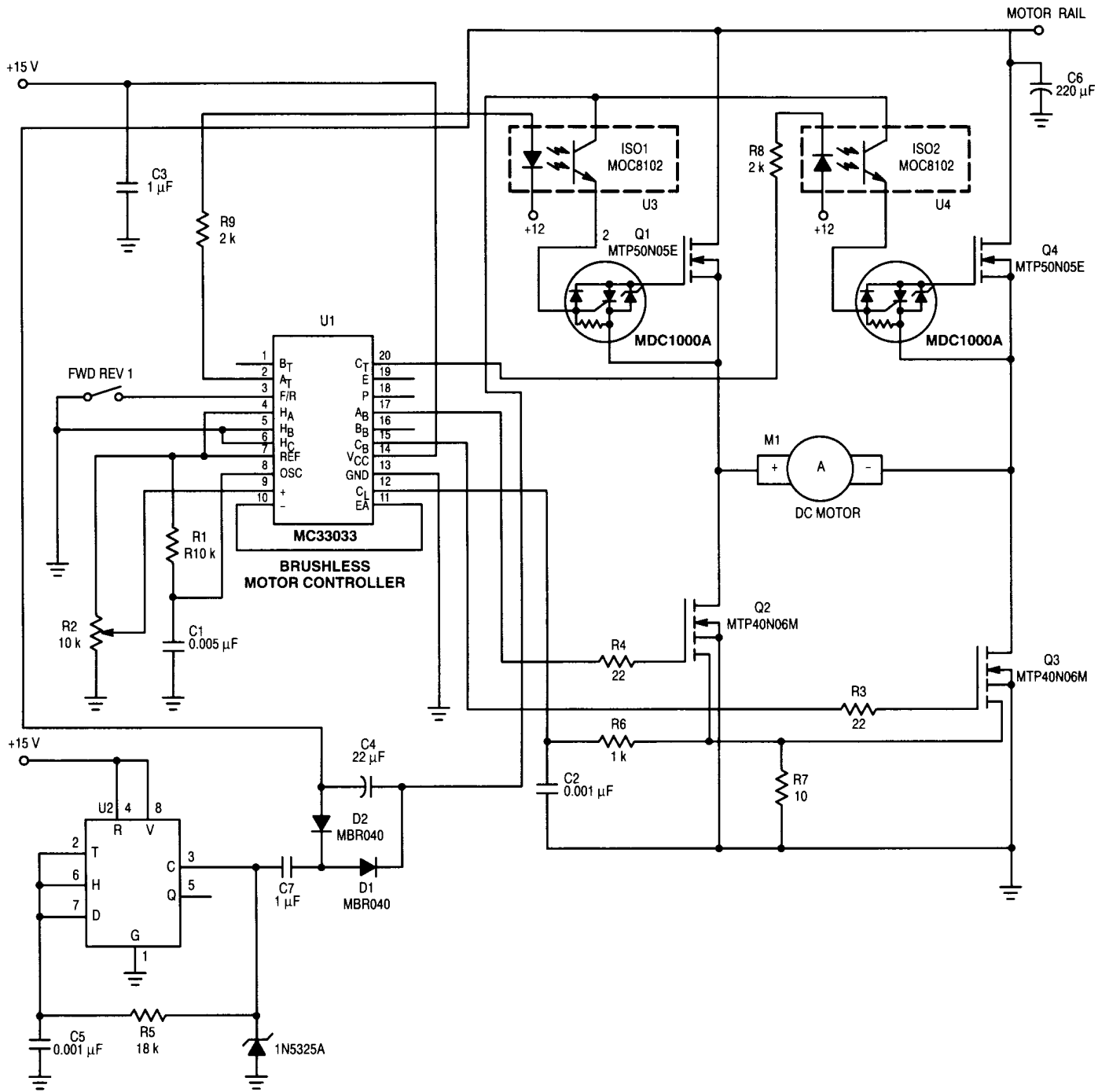

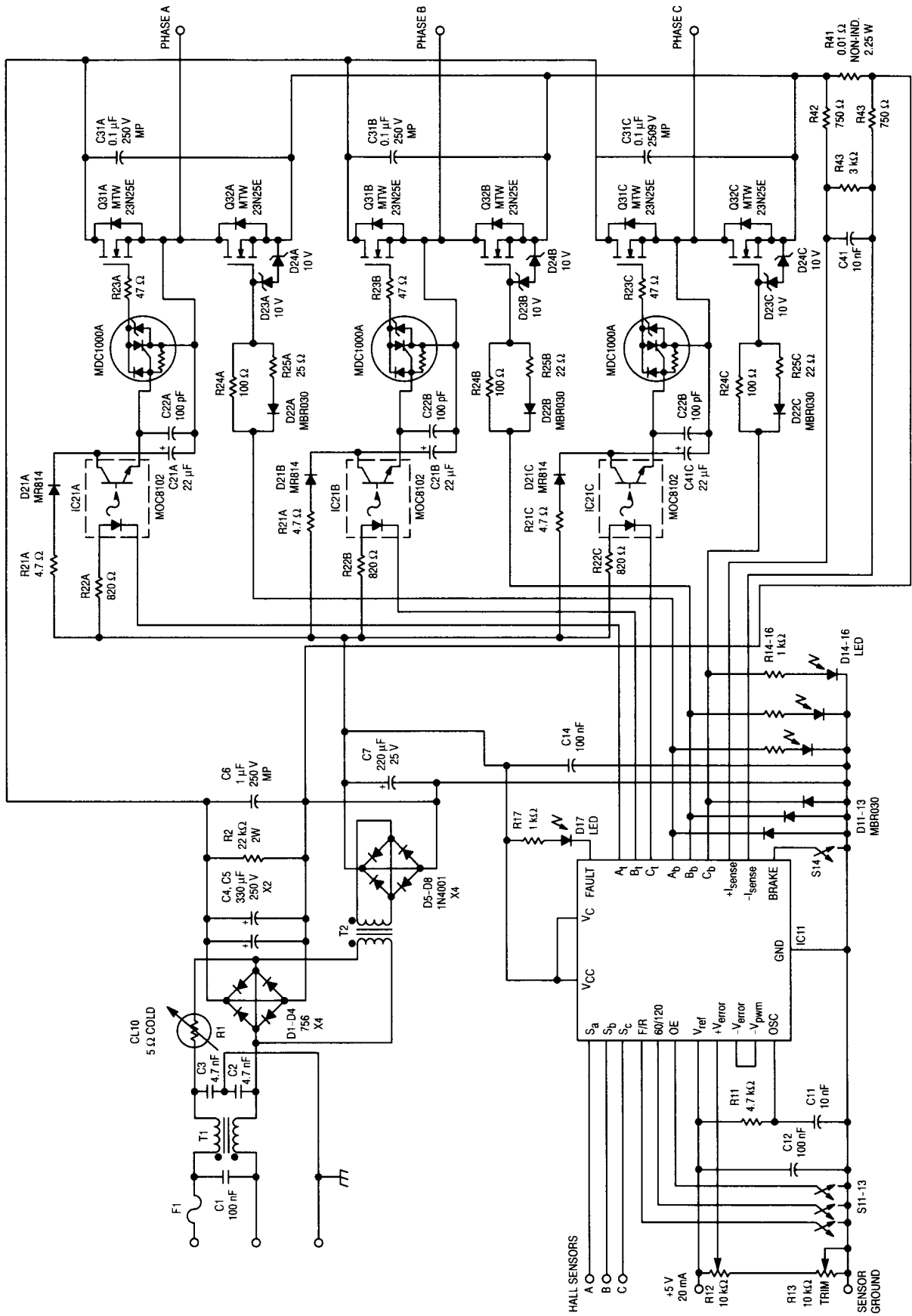

Figure 18. DC Motor Control With Optoisolated Level Shift

Motorola reserves the right to make changes without further notice to any products herein to improve reliability, function or design. Motorola does not assume any liability arising out of the application or use of any product or circuit described herein; neither does it convey any license under its patent rights nor the rights of others. Motorola products are not designed, intended, or authorized for use as components in systems intended for surgical implant into the body, or other applications intended to support or sustain life, or for any other application in which the failure of the Motorola product could create a situation where personal injury or death may occur. Should Buyer purchase or use Motorola products for any such unintended or unauthorized application, Buyer shall indemnify and hold Motorola and its officers, employees, subsidiaries, affiliates, and distributors harmless against all claims, costs, damages, and expenses, and reasonable attorney fees arising out of, directly or indirectly, any claim of personal injury or death associated with such unintended or unauthorized use, even if such claim alleges that Motorola was negligent regarding the design or manufacture of the part. Motorola and  are registered trademarks of Motorola, Inc. Motorola, Inc. is an Equal Opportunity/Affirmative Action Employer.



LOCATION IMPLIES PHYSICAL LAYOUT

Figure 19. Optoisolated Brushless DC Motor Drive

INFORMATION FOR USING THE SOT-23 AND SOT-223 SURFACE MOUNT PACKAGES

MINIMUM RECOMMENDED FOOTPRINTS FOR SURFACE MOUNTED APPLICATIONS

Surface mount board layout is a critical portion of the total design. The footprint for the semiconductor packages must be the correct size to insure proper solder connection interface

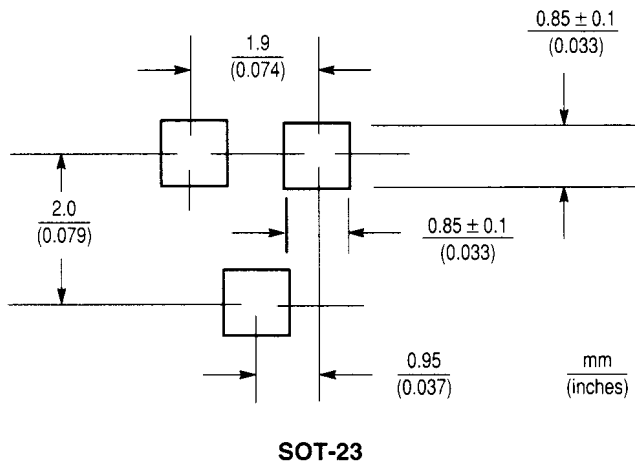

between the board and the package. With the correct pad geometry, the packages will self align when subjected to a solder reflow process.

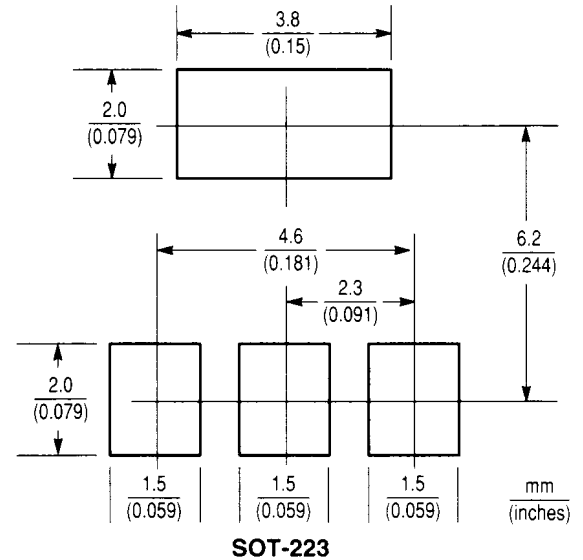

SOT-23 AND SOT-223 POWER DISSIPATION

The power dissipation for the SOT-23 (MDC1000BLT1) and the SOT-223 (MDC1000CT1) is a function of the input pad size. These can vary from the minimum pad size for soldering to the pad size given for maximum power dissipation. Power dissipation for a surface mount device is determined by $T_{J(max)}$, the maximum rated junction temperature of the die, $R_{\theta JA}$, the thermal resistance from the device junction to ambient; and the operating temperature, T_A . Using the values provided on the data sheet for the SOT-223 package, P_D can be calculated as follows:

$$P_D = \frac{T_{J(max)} - T_A}{R_{\theta JA}}$$

The values for the equation are found in the maximum ratings table on the data sheet. Substituting these values into the

equation for an ambient temperature T_A of 25°C, one can calculate the power dissipation of the device which in this case is 550 milliwatts.

$$P_D = \frac{150^\circ\text{C} - 25^\circ\text{C}}{227^\circ\text{C/W}} = 550 \text{ milliwatts}$$

The 227°C/W for the SOT-223 package assumes the recommended collector pad area of 11,850 mil² on a glass epoxy printed circuit board to achieve a power dissipation of 550 milliwatts using the footprint shown. Another alternative would be to use a ceramic substrate or an aluminum core board such as Thermal Clad™. Using a board material such as Thermal Clad, a power dissipation of 1.1 watts can be achieved using the same footprint. The same assumptions can be applied to the SOT-23 package.

MOUNTING PRECAUTIONS

The melting temperature of solder is higher than the rated temperature of the device and the entire device is heated to a high temperature; therefore failure to complete soldering within a short time could result in device failure. Therefore, the following items should always be observed in order to minimize the thermal stress to which the devices are subjected.

- Always preheat the device
- The delta temperature between the preheat and soldering should be 100°C or less*
- When preheating and soldering, the temperature of the leads and the case must not exceed the maximum temperature ratings as shown on the data sheet. When using infrared heating with the reflow soldering method, the difference in temperatures of the case and the leads shall be Δ10°C or less.

- The soldering temperature and time shall not exceed 260°C for more than 10 seconds.
- When shifting from preheating to soldering, the maximum temperature gradient shall be 5°C or less.
- After soldering has been completed, the device should be allowed to cool naturally for three minutes or more. Gradual cooling should be used as the use of forced cooling will increase the temperature gradient and result in latent mechanical stress.
- Mechanical stress or shock should not be applied during cooling.

* Soldering a device without preheating can cause excessive thermal shock and stress which can result in damage to the device.

OUTLINE DIMENSIONS

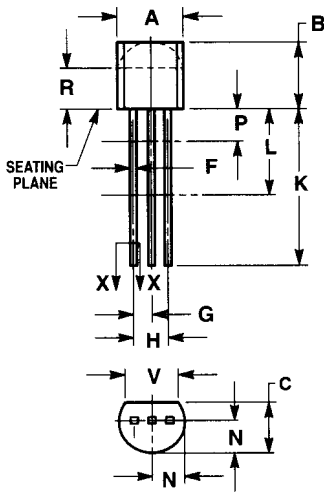

**CASE 29-04
TO-226AA
(TO-92)**

STYLE 33:
PIN 1: RETURN
2: INPUT
3: OUTPUT

- NOTES:
1. DIMENSIONING AND TOLERANCING PER ANSI Y14.5M, 1982.
 2. CONTROLLING DIMENSION: INCH.
 3. CONTOUR OF PACKAGE BEYOND DIM R IS UNCONTROLLED.
 4. DIM F APPLIES BETWEEN P AND L. DIM D AND J APPLIES BETWEEN L AND K. MINIMUM LEAD DIM IS UNCONTROLLED IN P AND BEYOND DIM K MINIMUM.
 5. 029-01 AND -02 OBSOLETE, NEW STANDARD 029-04.

DIM	MILLIMETERS		INCHES	
	MIN	MAX	MIN	MAX
A	4.45	5.20	0.175	0.205
B	4.32	5.33	0.170	0.210
C	3.18	4.19	0.125	0.165
D	0.41	0.55	0.016	0.022
F	0.41	0.48	0.016	0.019
G	1.15	1.39	0.045	0.055
H	2.42	2.66	0.095	0.105
J	0.39	0.50	0.015	0.020
K	12.70	—	0.500	—
L	6.35	—	0.250	—
N	2.04	2.66	0.080	0.105
P	—	2.54	—	0.100
R	2.93	—	0.115	—
V	3.43	—	0.135	—

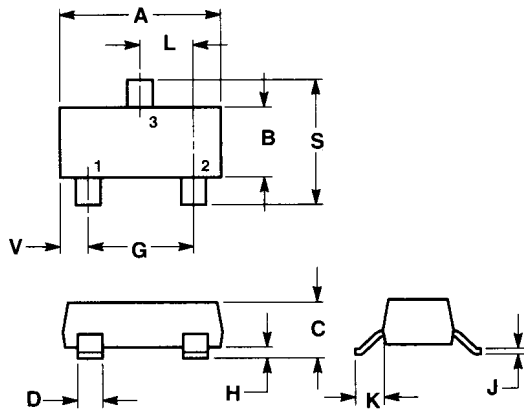

**CASE 318-07
TO-236AB
(SOT-23)**

STYLE 22:
PIN 1: RETURN
2: OUTPUT
3: INPUT

- NOTES:
1. DIMENSIONING AND TOLERANCING PER ANSI Y14.5M, 1982.
 2. CONTROLLING DIMENSION: INCH.
 3. MAXIMUM LEAD THICKNESS INCLUDES LEAD FINISH THICKNESS. MINIMUM LEAD THICKNESS IS THE MINIMUM THICKNESS OF BASE MATERIAL.
 4. 318-03 OBSOLETE, NEW STANDARD 318-07.

DIM	MILLIMETERS		INCHES	
	MIN	MAX	MIN	MAX
A	2.80	3.04	0.1102	0.1197
B	1.20	1.40	0.0472	0.0551
C	0.89	1.11	0.0350	0.0440
D	0.37	0.50	0.0150	0.0200
G	1.78	2.04	0.0701	0.0807
H	0.013	0.100	0.0005	0.0040
J	0.085	0.177	0.0034	0.0070
K	0.45	0.60	0.0180	0.0236
L	0.89	1.02	0.0350	0.0401
S	2.10	2.50	0.0830	0.0984
V	0.45	0.60	0.0177	0.0236

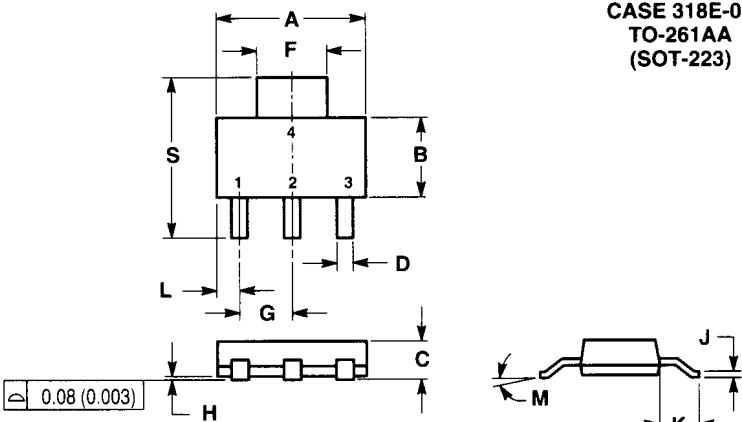

**CASE 318E-04
TO-261AA
(SOT-223)**

STYLE 6:
PIN 1: RETURN
2: INPUT
3: OUTPUT
4: INPUT

- NOTES:
1. DIMENSIONING AND TOLERANCING PER ANSI Y14.5M, 1982.
 2. CONTROLLING DIMENSION: MILLIMETERS.
 3. 318E-01 THRU -03 OBSOLETE, NEW STANDARD 318E-04.

DIM	MILLIMETERS		INCHES	
	MIN	MAX	MIN	MAX
A	6.30	6.70	0.249	0.263
B	3.30	3.70	0.130	0.145
C	1.50	1.75	0.060	0.068
D	0.60	0.89	0.024	0.035
F	2.90	3.20	0.115	0.126
G	2.20	2.40	0.087	0.094
H	0.020	0.100	0.0008	0.0040
J	0.24	0.35	0.009	0.014
K	1.50	2.00	0.060	0.078
L	0.85	1.05	0.033	0.041
M	0°	10°	0°	10°
S	6.70	7.30	0.264	0.287