

IGBT

200 A 600 V

PDMB200A6  
PDMB200A6C

回路図 CIRCUIT

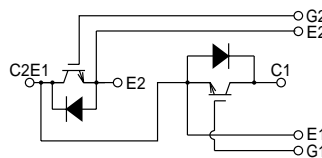

外形寸法図 OUTLINE DRAWING  
PDMB200A6

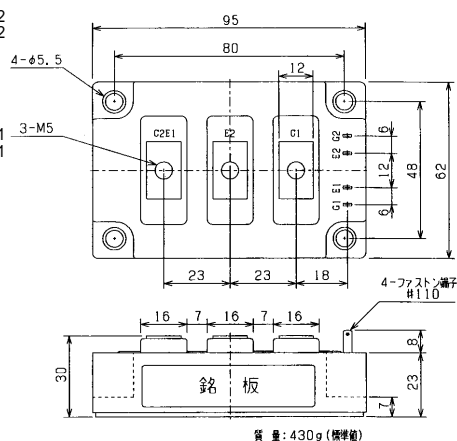

(単位 Dimension : mm)

PDMB200A6C

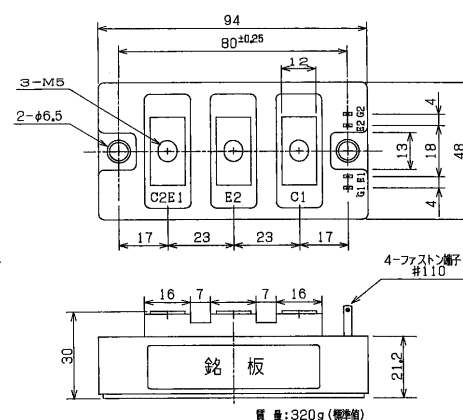

最大定格 Maximum Ratings ( Tc = 25 )

項目 Item	記号 Symbol	定格値 Rated Value	単位 Unit
コレクタ・エミッタ間電圧 Collector-Emitter Voltage	V <sub>CEs</sub>	600	V
ゲート・エミッタ間電圧 Gate-Emitter Voltage	V <sub>GES</sub>	± 20	V
コレクタ電流 Collector Current	DC	I <sub>c</sub>	A
	1ms	I <sub>CP</sub>	
コレクタ損失 Collector Power Dissipation	P <sub>c</sub>	780	W
接合温度 Junction Temperature Range	T <sub>j</sub>	- 40 ~ + 150	
保存温度 Storage Temperature Range	T <sub>stg</sub>	- 40 ~ + 125	
絶縁耐圧 端子 - ベース間, AC 1 分間) Isolation Voltage (Terminal to Base, AC 1 min.)	V <sub>iso</sub>	2500	V <sub>(RMS)</sub>
締付トルク Mounting Torque	ベース取付部 Module Base to Heatsink	PDMB200A6 2 ( 20.4 )	N・m ( kgf・cm )
	端子部 Busbar to Terminal	PDMB200A6C 3 ( 30.6 ) 2 ( 20.4 )	

電気的特性 Electrical Characteristics ( Tc = 25 )

項目 Characteristic	記号 Symbol	条件 Test Conditions	最小 Min.	標準 Typ.	最大 Max.	単位 Unit
コレクタ遮断電流 Collector-Emitter Cut-Off Current	I <sub>CES</sub>	V <sub>CE</sub> = 600V, V <sub>GE</sub> = 0V			2.0	mA
ゲート漏れ電流 Gate-Emitter Leakage Current	I <sub>GES</sub>	V <sub>GE</sub> = ± 20V, V <sub>CE</sub> = 0V			500	nA
コレクタ・エミッタ間飽和電圧 Collector-Emitter Saturation Voltage	V <sub>CE(sat)</sub>	I <sub>c</sub> = 200A, V <sub>GE</sub> = 15V		2.1	2.6	V
ゲートしきい値電圧 Gate-Emitter Threshold Voltage	V <sub>GE(th)</sub>	V <sub>CE</sub> = 5V, I <sub>c</sub> = 200mA	4.0		8.0	V
入力容量 Input Capacitance	C <sub>ies</sub>	V <sub>CE</sub> = 10V, V <sub>GE</sub> = 0V, f = 1MHz		20000		pF
スイッチング時間 Switching Time	上昇時間 Rise Time	V <sub>CC</sub> = 300V R <sub>L</sub> = 3 R <sub>G</sub> = 3.6 V <sub>GE</sub> = ± 15V		0.15	0.3	μs
	ターン・オン時間 Turn-On Time			0.25	0.4	
	下降時間 Fall Time			0.2	0.35	
	ターン・オフ時間 Turn-Off Time			0.45	0.7	

フリーホイーリングダイオードの特性 Free Wheeling Diode Ratings & Characteristics (  $T_c = 25$  )

項 目 Item		記号 Symbol	定 格 値 Rated Value	単位 Unit
順電流 Forward Current	DC	$I_F$	200	A
	1ms	$I_{FM}$	400	

項 目 Characteristic	記号 Symbol	条 件 Test Conditions	最小 Min.	標準 Typ.	最大 Max.	単位 Unit
順電圧 Peak Forward Voltage	$V_F$	$I_F = 200A, V_{GE} = 0V$		1.9	2.4	V
逆回復時間 Reverse Recovery Time	$t_{rr}$	$I_F = 200A, V_{GE} = -10V$ $di/dt = 200A/\mu s$		0.15	0.25	$\mu s$

熱的特性 Thermal Characteristics

項 目 Characteristic	記号 Symbol	条 件 Test Conditions	最小 Min.	標準 Typ.	最大 Max.	単位 Unit
熱抵抗 Thermal Impedance	IGBT	接合部 - ケース間 Junction to Case			0.16	/W
	Diode				0.38	

定格・特性曲線

Fig. 1 Output Characteristics (Typical)

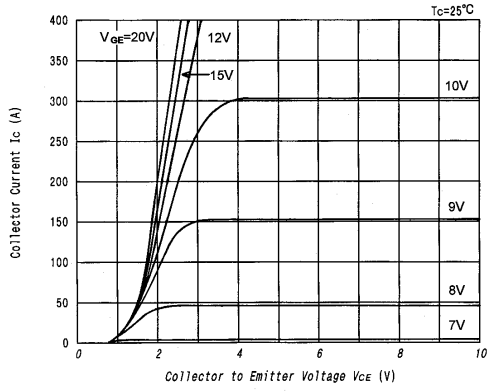

Fig. 2 Collector to Emitter on Voltage vs. Gate to Emitter Voltage (Typical)

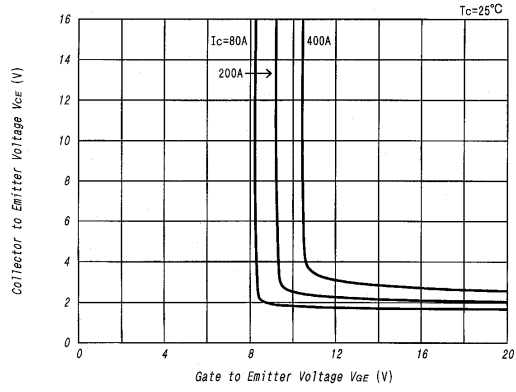

Fig. 3 Collector to Emitter on Voltage vs. Gate to Emitter Voltage (Typical)

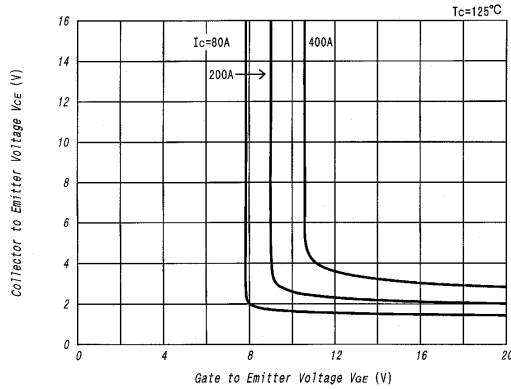

Fig. 4 Gate Charge vs. Collector to Emitter Voltage (Typical)

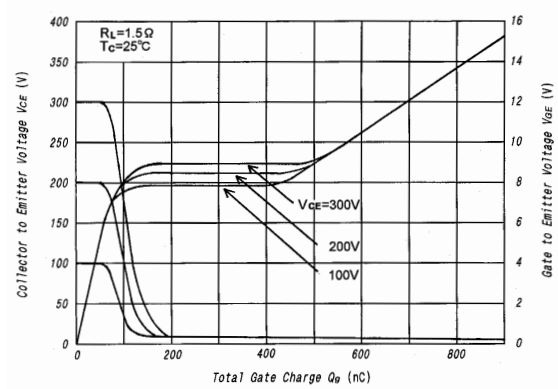

Fig. 5 Capacitance vs. Collector to Emitter Voltage (Typical)

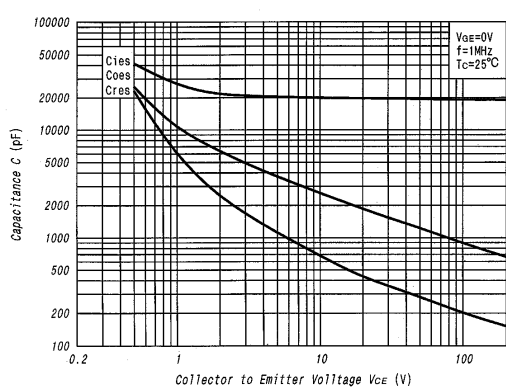

Fig. 6 Collector Current vs. Switching Time (Typical)

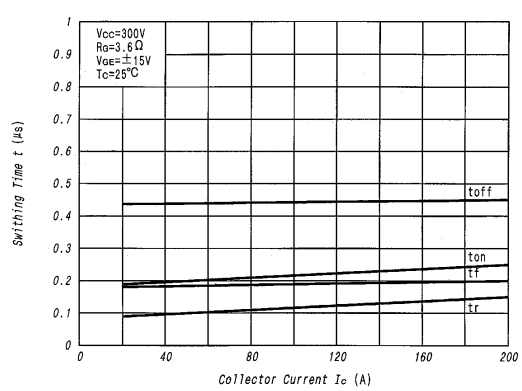

Fig. 7 Series Gate Impedance vs. Switching Time (Typical)

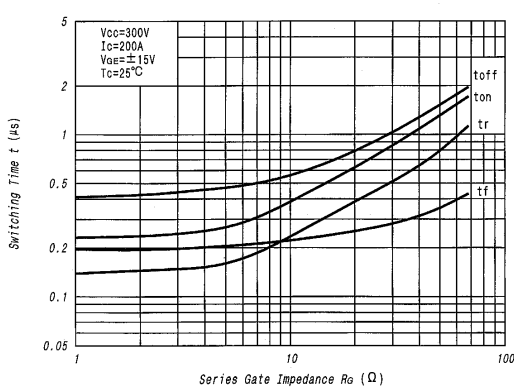

Fig. 8 Forward Characteristics of Free Wheeling Diode (Typical)

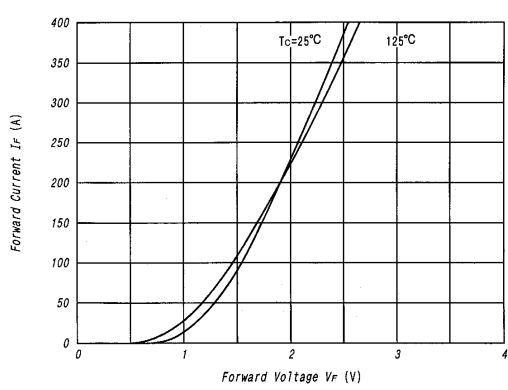

Fig. 9 Reverse Recovery Capacitance (Typical)

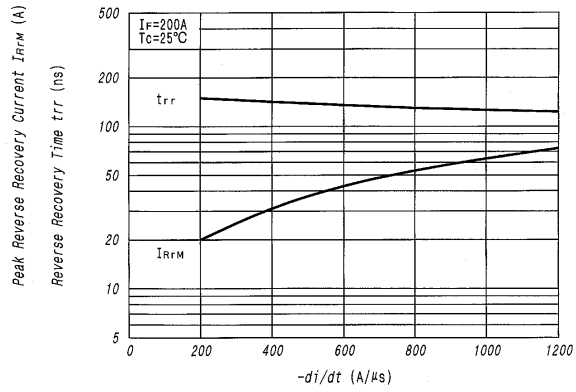

Fig. 10 Reverse Bias Safe Operating Area

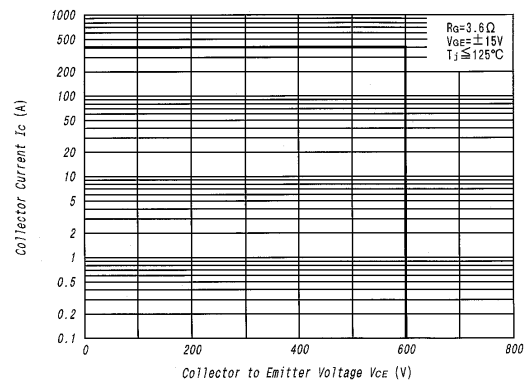

Fig. 11 Transient Thermal Impedance

