



Micro Commercial Components  
 21201 Itasca Street Chatsworth  
 CA 91311  
 Phone: (818) 701-4933  
 Fax: (818) 701-4939

# MBR30020 THRU MBR30045

## Features

- Metal of siliconrectifier, majonty carrier conducton
- Guard ring for transient protection
- Low power loss high efficiency
- High surge capacity, High current capability

## 300 Amp Schottky Barrier Rectifier 20 to 45V olts

## Maximum Ratings

- Operating Junction Temperature: -55°C to +175°C
- Storage Temperature: -55°C to +175°C
- Typical Thermal Resistance per leg 0.4°C/W Junction to Case

MCC Part Number	Maximum Recurrent Peak Reverse Voltage	Maximum RMS Voltage	Maximum DC Blocking Voltage
MBR30020	20V	14V	20V
MBR30030	30V	21V	30V
MBR30035	35V	24.5V	35V
MBR30040	40V	28V	40V
MBR30045	45V	31.5V	45V

## HALF PACK

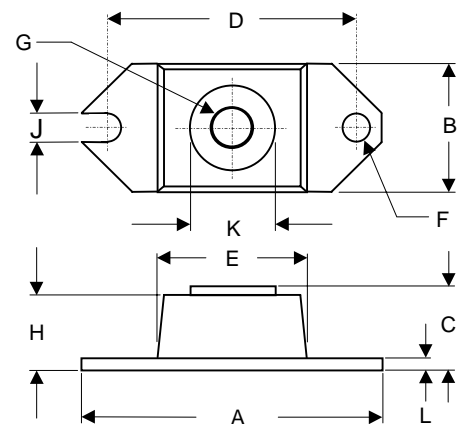

## Electrical Characteristics @ 25°C Unless Otherwise Specified

Average Forward Current	$I_{F(AV)}$	300 A	$T_C = 133^\circ\text{C}$
Peak Forward Surge Current	$I_{FSM}$	3400A	8.3ms, half sine
Maximum Instantaneous Forward Voltage MBR30020-30045	$V_F$	.63 V	$I_{FM} = 300\text{A};$ $T_J = 25^\circ\text{C}$
Maximum DC Reverse Current At Rated DC Blocking Voltage	$I_R$	$\text{mA}$ 200mA	$T_J = 25^\circ\text{C}$ $T_J = 125^\circ\text{C}$
Typical Junction Capacitance	$C_J$	9500pF	Measured at 1.0MHz, $V_R=5.0\text{V}$

DIM	DIMENSIONS				NOTE
	INCHES		MM		
	MIN	MAX	MIN	MAX	
A	1.515	1.560	38.48	39.62	
B	.725	.775	18.42	19.69	
C	.595	.625	15.11	15.88	
D	1.182	1.192	30.02	30.28	
E	.745	.755	18.92	19.18	
F	.152	.160	3.86	4.06	∅
G	1/4 - 20		UNC - 2B		
H	.540	.580	13.72	14.73	
J	.15	.160	3.96	4.06	
K	.495	.505	12.57	12.83	∅
L	.120	.130	3.05	3.30	

\*Pulse Test: Pulse Width 300µsec, Duty Cycle 2%

Figure 1  
Typical Forward Characteristics

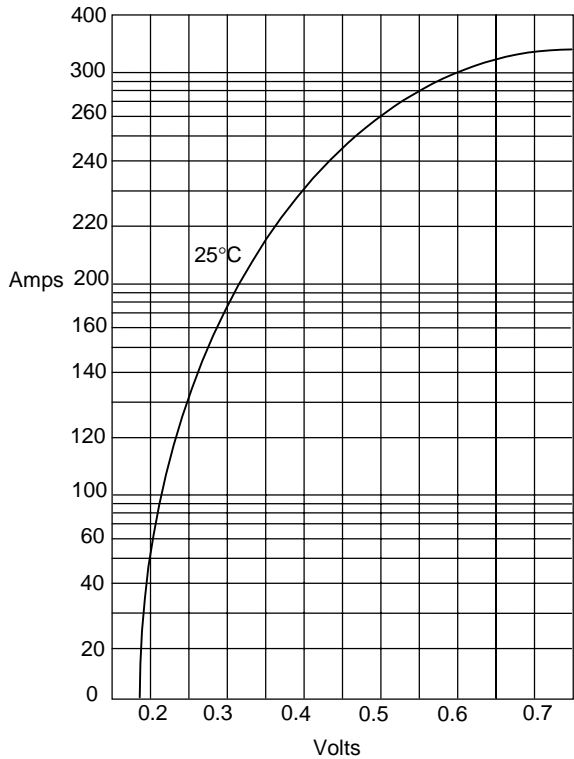

Instantaneous Forward Current - Amperes versus  
Instantaneous Forward Voltage - Volts

Figure 2  
Forward Derating Curve

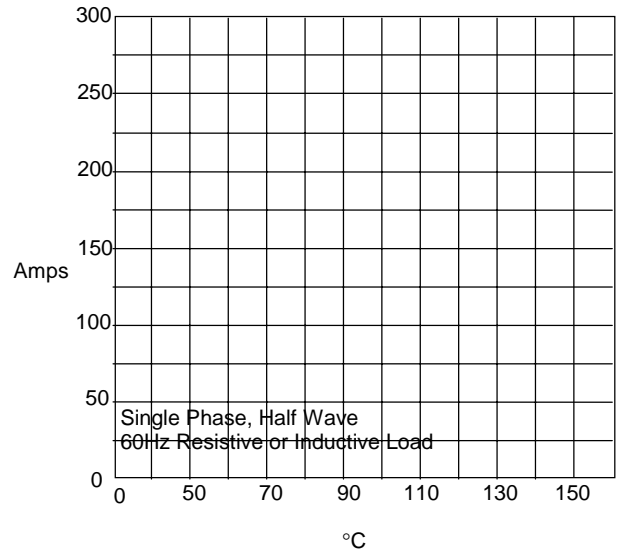

Average Forward Rectified Current - Amperes versus  
Case Temperature - °C

Figure 3  
Junction Capacitance

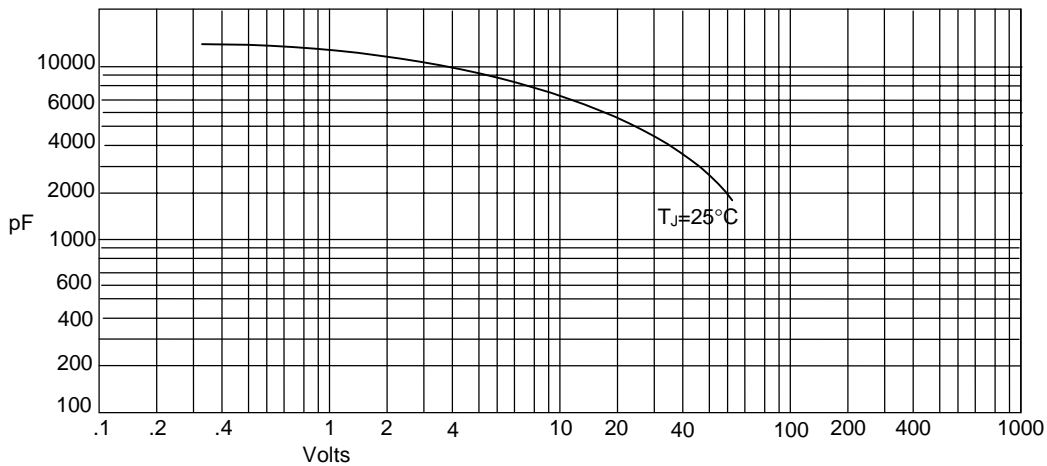

Junction Capacitance - pF versus  
Reverse Voltage - Volts

Figure 4  
Typical Reverse Characteristics

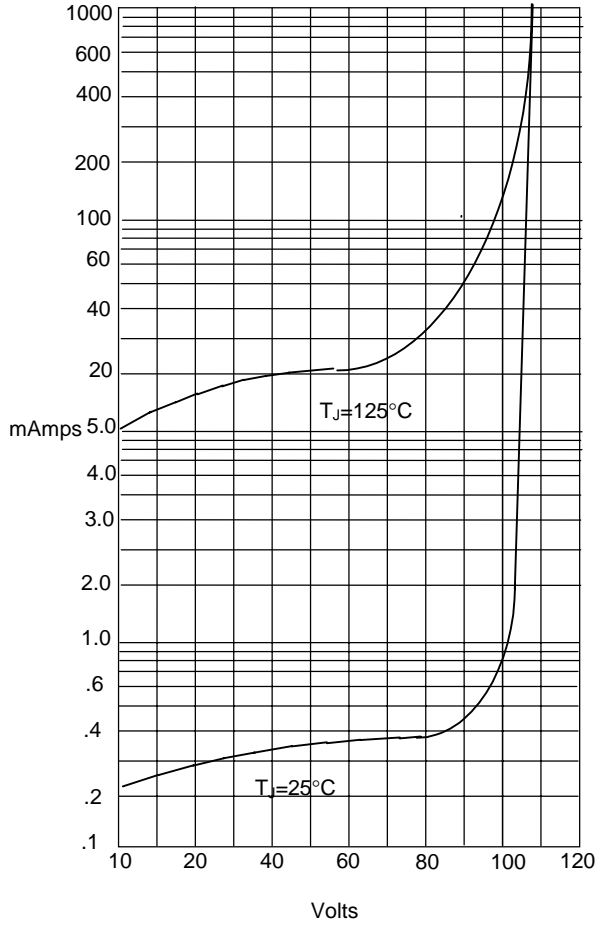

Instantaneous Reverse Leakage Current - MicroAmperes versus Percent Of Rated Peak Reverse Voltage - Volts

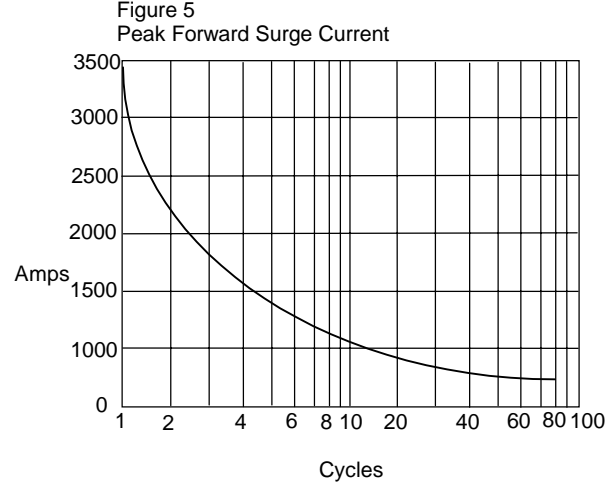

Peak Forward Surge Current - Amperes versus Number Of Cycles At 60Hz - Cycles