

AM80A Performance Series



DC-DC Converter Module Technical Reference Manual

Series Highlights

- High Efficiency - up to 88%
- 100°C baseplate/ case operating temperature - no derating
- Fixed Switching Frequency
- Low output ripple and noise
- High Reliability - over 1 million hours MTBF
- Designed to meet all Telecom specifications

Contents

Introduction	4
Special Features	4
Ordering Information	5
Safety	5
Electrical Specifications	6
Absolute Maximum Ratings – all models	6
Pin Connections - all models except AM80A-048L-050P25D033P30	7
Pin Connections - AM80A-048L-050P25D033P30	9
Insulation - all models	10
Electrical Specifications for 48V Input Models (AM80A-048L-xxxFyy)	11
Electrical Specifications for 48V Input Models (AM80A-048L-050P25D033P30)	13
Electrical Specifications for 150V Input Models (AM80A-150L-xxxFyy)	14
Electrical Specifications for 300V Input Models (AM80A-300L-xxxFyy)	15
Electrical Specifications for 320V Input Models (AM80A-320L-xxxFyy)	17
Functional Description	18
Remote Sense (+SENSE, -SENSE)	18
Enable Control (ENABLE)	18
Output Voltage Adjustment (V ADJ)	19
Current Limit Adjustment (C LIM ADJ)	19
Overvoltage Protection Adjustment (OVP ADJ)	19
Power Good/Identification (PG/ID)	20
Clock Signals (CLK IN, CLK OUT)	20
Current Sharing (C SHARE)	21
Current Monitoring (C MON)	21
Temperature Monitoring (TEMP MON)	21
Design Considerations	22
Input Bulk Capacitors	22
Remote Loads	22
Thermal Data	22
Overtemperature Protection	22
Parallel Connection Considerations	23

Output Ripple and Noise	23
Conducted EMI	23
Break Regulation	23
Input Undervoltage Protection	24
Application Examples	25
AC Input Design	25
Parallel Connection Design	25
Mechanical Information	26
Dimensions	26
Recommended PCB Layout	27
Dimensions of AM80A-048L-050P25D033P30	28
Recommended PCB Layout	29
Heatsink Mounting Information	30

AM80A Performance Series DC-DC Converters

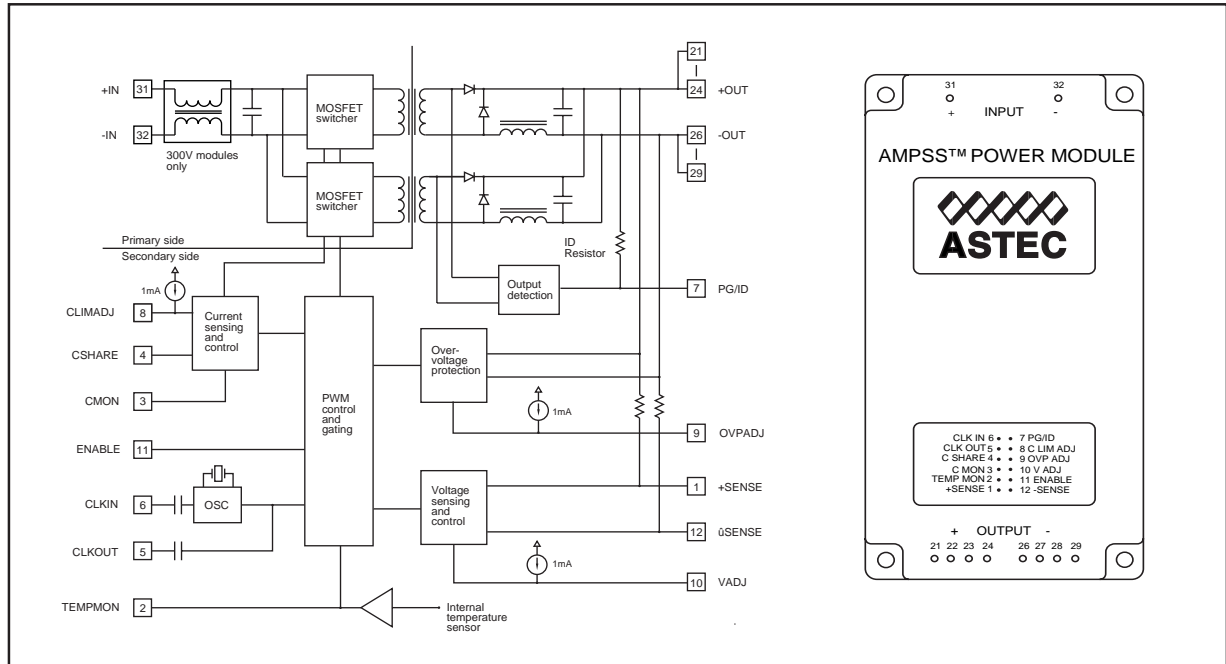

Introduction

The single output AM80A is an isolated, single output DC to DC converter module, providing up to 252W output with a maximum baseplate operating temperature of 100°C with no derating. The AM80A features full safety isolated low voltage secondary side control and Astec Linear Programming (ALP™) for convenient adjustment of the module's parameters.

The dual output AM80A provides two outputs, 3.3V and 5.0V.

Special Features

- High Efficiency - up to 88%
- 1MHz fixed switching frequency
- 100°C baseplate/ case operating temperature - no derating
- Low output ripple and noise
- Excellent transient response
- Safety isolated low voltage interface with ALP™ linear control
- High Reliability - over 1 million hours MTBF
- Wide input voltage range
- Parallelable with accurate current sharing
- Current and temperature monitoring outputs

Ordering Information

Model Number	Input Voltage	Output Voltage	Output Current	Output Power
A M 80 A -320L-280F09	320V	28V	9A	252W
A M 80 A -300L-022F60	300V	2.2V	60A	132W
A M 80 A -300L-033F50	300V	3.3V	50A	165W
A M 80 A -300L-050F40	300V	5V	40A	200W
A M 80 A -300L-120F18	300V	12V	18A	216W
A M 80 A -300L-150F16	300V	15V	16A	240W
A M 80 A -300L-065F33	300V	6.5V	33A	214.5W
A M 80 A -300L-240F10	300V	24V	10A	240W
A M 80 A -300L-280F09	300V	28V	9A	252W
A M 80 A -150L-065F33	150V	6.5V	33A	214.5W
A M 80 A -048L-012F60	48V	1.2V	60A	72W
A M 80 A -048L-022F60	48V	2.2V	60A	132W
A M 80 A -048L-033F50	48V	3.3V	50A	165W
A M 80 A -048L-050F40	48V	5V	40A	200W
A M 80 A -048L-120F18	48V	12V	18A	216W
A M 80 A -048L-150F16	48V	15V	16A	240W
A M 80 A -048L-240F10	48V	24V	10A	240W
A M 80 A -048L- 050P25	48V	5V	25A	125W
D033P30	48V	3.3V	30A	99W

Please contact Astec for information on other output voltages, power ranges and configurations.

Safety

UL:	UL1950
CSA:	CSA C22.2No.950
VDE:	VDE0805
	EN60950
CE:	CEMark

Please contact Astec for information on specific module approvals.

Note: Ensure all modules are used according to the Installation Instructions provided with each module.

All modules are designed to meet the following specifications:

ETS300-132-2
ETS300-386-1⁽¹⁾
EN55022-A⁽¹⁾
EN55022-B⁽¹⁾
EN41003
IEC6100-44⁽¹⁾
IEC6100-45⁽¹⁾
IEC950
VDE0871-A⁽¹⁾
VDE0878-A⁽¹⁾
BTNR2511(5)⁽¹⁾

⁽¹⁾Require additional circuitry for full compliance. Please refer to application section of this manual or contact technical support office for further information.

Electrical Specifications

Absolute Maximum Ratings – all models

Exceeding the specified absolute maximum ratings may severely damage the module. These ratings are intended as guidelines for absolute worst case operating conditions and are not to be interpreted as recommended operating condition

General	320 V Input	300 V Input	150V Input	48V Input
Continuous Input Voltage	400V	400V	200V	72V
Input Surge Voltage (1 sec)	425V	425V	225V	75V (continuous)
Isolation, Input to Output*	2700VDC	2700VDC	2700VDC	2100VDC
Isolation Input to Baseplate*	2121VDC	2121VDC	2121VDC	2100VDC
Isolation, Output to Baseplate*	500VDC	500VDC	500VDC	500VDC
Operating Temperature (Baseplate) /Case	-20 to 100°C *			
Storage Temperature	-40 to 105°C			
Operating Relative Humidity (non-condensing)	10% to 95%			
Storage Relative Humidity (non-condensing)	95% Max			
Altitude (Operating)	< 3000m			
Altitude (Storage)	< 9000m			
Lead Temperature (soldering 5 Seconds)	235°C			

Notes:

* For 300/320V input :

All isolation barriers on 300V input modules have been designed and tested to meet 4242VDC as required by IEC950 for reinforced insulation. The complete module should NOT be subjected to a 3000VAC input-to-output test because this can result in input-baseplate-output breakdown. AMPSS DC-DC modules are CLASS I equipment. Power supply systems using AMPSS modules MUST also be CLASS I equipment. Each AMPSS DC-DC module is fully tested in factory according to the standards. Therefore power supply systems need only be subjected to Hi-Pot test for BASIC insulation which is 1500Vac (AC) input to GROUND.

Secondary Control Pins	
+SENSE	$V_o - 0.5$ to $V_o + 0.5$ VDC
-SENSE	-0.5 to 0.5 VDC
TEMP MON	-0.5 to 7 VDC
C MON	-0.5 to 7 VDC
C SHARE	-0.5 to 7 VDC
CLK OUT	-50 to 50 VDC
CLK IN	-50 to 50 VDC
CLIM ADJ	-0.5 to 7 VDC
OVP ADJ	-0.5 to 7 VDC
V ADJ	-0.5 to 7 VDC
PG/ID	0.5 to $V_o + 0.5$ VDC
ENABLE	-0.5 to 20 VDC

Note : V_o = module output voltage
All voltage referenced to negative output

Specifications

Electrical characteristics are guaranteed over the full baseplate/ case temperature range (-20 to 100°C*) and for the full range of input voltage (V_i) and for the full load range (0 to I_o rated). Except where indicated, +SENSE and -SENSE are connected to the output terminals at the point of measurement, ENABLE is connected to -SENSE. All other pins are left floating.

Definitions

V_i , V_o and I_o are actual operating conditions, V_{Inom} , V_{Onom} and I_{Orated} are nominal ratings.

*Note : AM80A-048L-050P25D033P30 Baseplate/ Case Operating Temperature is -20 to 85°C.

Pin Connections - all models except AM80A-048L-050P25D033P30

INPUT PINS

Pin No	Pin Name	Type	Description	Recommended Connections
31	+INPUT	Input	Power input - positive	A 220µF electrolytic capacitor connected between the +INPUT and -INPUT pins is recommended
32	-INPUT	Input	Power input - negative (return)	See +INPUT for recommendations

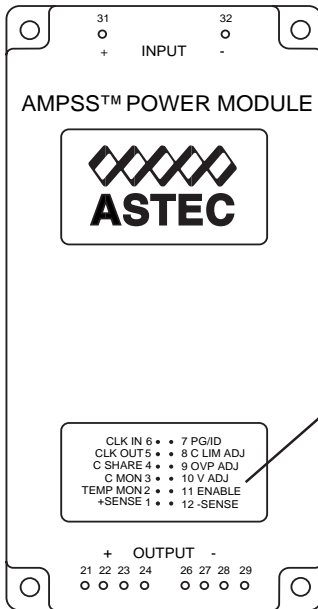

CONTROL PINS

Pin No	Pin Name	Type	Description	Recommended Connections
1	+SENSE	Input	Used for remote sense function to compensate for load bus resistance	If remote sensing is not required connect to +OUTPUT pins 21-24 of the module
2	TEMP MON	Output	Provides a voltage signal proportional to the internal absolute temperature of the module	Analog signal output. Leave unconnected if not used
3	C MON	Output	Provides a current signal proportional to the current being supplied by the module	Analog signal output. Leave unconnected if not used
4	C SHARE	Input/Output	Allows modules connected in parallel to accurately share current	Connect to C SHARE pins of other modules. Leave unconnected if not used
5	CLK OUT	Output	Provides a 1MHz clock output for synchronization with other modules	Capacitor coupled output. Leave unconnected if not used
6	CLK IN	Input	Accepts a 1MHz clock input for synchronization with other modules	Capacitor coupled input. Leave unconnected if not used
7	PG/ID	Output	High level output ($V_{PG/ID} = V_o$) indicates module converter is running. Can also be used to identify the nominal output voltage of the module by measuring resistance between PG/ID and +OUTPUT	ID Resistance = $[V_{o(nom)}]KW$ Leave unconnected if not use
8	C LIM ADJ	Input	Used to adjust the current limit set point	Internal 1mA current source. Leave unconnected if not used
9	OVP ADJ	Input	Used to adjust module output overvoltage threshold	Internal 1mA current source. Leave unconnected if not used
10	V ADJ	Input	Used to adjust module output voltage	Internal 1mA current source. Leave unconnected if not used
11	ENABLE	Input	Enables or disables the output of the module	Must be connected to -SENSE pin or driven to <0.7V to enable the output of the module
12	-SENSE	Input/reference	Used for remote sense function to compensate for load bus resistance	If remote sensing is not required connect to -OUTPUT pins 26-29 of the module

OUTPUT PINS

Pin No	Pin Name	Type	Description	Recommended Connections
21-24	+OUTPUT	Output	Power output - positive	Ensure good electrical connection and sufficient copper on PCB layouts
26-29	-OUTPUT	Output	Power output - negative	See +OUTPUT for recommendations

All Models Except AM80A-048L-050P25D033P30

CONTROL SIGNALS

Control Function	Conditions	Parameter	Min	Typ	Max	Units
TEMP MON - temperature monitor signal		V _{TMON} sensitivity	9.8	10	10.2	mV/°C
		Source impedance		1		KW
C MON - current monitor signal	I _O = I _{O rated}	I _{C MON}	0.9	1	1.1	mA
		Measured Range	20		100	% I _{O rated}
C SHARE - current share function	C SHARE pins of modules in parallel connected	C SHARE accuracy		±3%	±10	% I _{O rated}
		Max no. of units			10	
CLK OUT - clock output	CLK IN open	V _{CLK OUT}	3.3		5.5	V _{p-p}
		Clock freq.	0.98	1	1.02	MHz
		Max fan out			2	
CLK IN - clock input		V _{CLK IN}	3.3		5.5	V _{p-p}
		Clock freq	0.9	1	1.1	MHz
		V _{PG/ID}		100		% V _O
PG/ID power good / Identification function	Converter running :					
	I _O ³ 5% I _{O rated} for I _{O rated} ³ 20A					
	I _O > 1A for I _{O rated} < 20A					
	Converter not running 320V, 300V & 150V Input	V _{PG/ID}			0.2	V
	Converter not running 48V Input	V _{PG/ID}			1.0	V
	5V output	Resistance; PG/ID to positive output terminal	5.00	5.1	6.12	KΩ
	6.5V output		6.66	6.8	7.82	KΩ
12V output	11.76		12	13.02	KΩ	
15V output	14.70		15	16.02	KΩ	
24V output	23.52		24	25.02	KΩ	
28V output	26.46	27	28.02	KΩ		
C LIM ADJ - current limit adjustment	V _{C LIM ADJ} = 0.8V	C LIM set point		20		% I _{O max}
	V _{C LIM ADJ} = 4.0V	C LIM set point		100		% I _{O max}
	V _{C LIM ADJ} = 1V	C LIM current source	0.95	1	1.05	mA
OVP ADJ ¹ - output overvoltage protection adjustment	V _{OVP ADJ} = 0V	OVP set point			150	% V _{O nom}
	V _{OVP ADJ} >= 1V	OVP set point	110			% V _{O nom}
	V _{OVP ADJ} = 1V	OVP ADJ current source	0.95	1	1.05	mA
V ADJ - voltage adjust	V _{V adj} = 0V	V _O	78	80	82	% V _{O nom}
	V _{V adj} = 2V	V _O	118	120	122	% V _{O nom}
	V _{V ADJ} = 1V	V ADJ current source	0.95	1	1.05	mA
ENABLE - module enable	Module enabled	V _{ENABLE}	0		0.7	V
	Module disabled	V _{ENABLE}	2		10	V
	V _{ENABLE} = 0.7V	ENABLE current source		100	150	μA

Notes :

1. OVP trip point must be adjusted to accommodate maximum remote sense compensation

Pin Connections - AM80A-048L-050P25D033P30

INPUT PINS

Pin No	Pin Name	Type	Description	Recommended Connections
31	+INPUT	Input	Power input - positive	A 220µF electrolytic capacitor connected between the +INPUT and -INPUT pins is recommended
32	-INPUT	Input	Power input - negative (return)	See +INPUT for recommendations

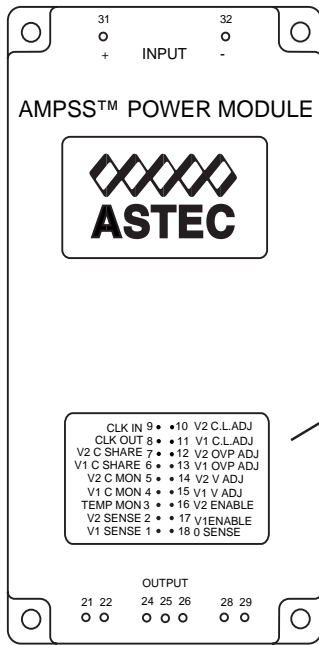

CONTROL PINS

Pin No	Pin Name	Type	Description	Recommended Connections
1	V1 SENSE	Input	Used for remote sense function to compensate for load bus resistance	If remote sensing is not required connect to V1+OUTPUT pins 28-29 of the module
2	V2 SENSE	Input	Used for remote sense function to compensate for load bus resistance	If remote sensing is not required connect to V2+OUTPUT pins 21-22 of the module
3	TEMP MON	Output	Provides a voltage signal proportional to the internal absolute temperature of the module	Analog signal output. Leave unconnected if not used
4	V1 C MON	Output	Provides a current signal proportional to the current being supplied by V1	Analog signal output. Leave unconnected if not used
5	V2 C MON	Output	Provides a current signal proportional to the current being supplied by the V2	Analog signal output. Leave unconnected if not used
6	V1 C SHARE	Input/Output	Allows V1 connected in parallel to accurately share current	Connect to C SHARE pins of other modules. Leave unconnected if not used
7	V2 C SHARE	Input/Output	Allows V2 connected in parallel to accurately share current	Connect to C SHARE pins of other modules. Leave unconnected if not used
8	CLK OUT	Output	Provides a 1MHz clock output for synchronization with other modules	Capacitor coupled output. Leave unconnected if not used
9	CLK IN	Input	Accepts a 1MHz clock input for synchronization with other modules	Capacitor coupled input. Leave unconnected if not used
10	V2 C.L.ADJ	Input	Used to adjust the current limit set point (of V2)	Internal 1mA current source. Leave unconnected if not used
11	V1 C.L.ADJ	Input	Used to adjust the current limit set point (of V1)	Internal 1mA current source. Leave unconnected if not used
12	V2 OVP ADJ	Input	Used to adjust overvoltage protection of V2	Internal 1mA current source. Leave unconnected if not used
13	V1 OVP ADJ	Input	Used to adjust overvoltage protection of V1	Internal 1mA current source. Leave unconnected if not used
14	V2 V ADJ	Input	Used to adjust module output voltage of V2	Internal 1mA current source. Leave unconnected if not used
15	V1 V ADJ	Input	Used to adjust module output voltage of V1	Internal 1mA current source. Leave unconnected if not used
16	V2 ENABLE	Input	Enables or disables the output of V2	Must be connected to -SENSE pin or driven to <-0.7V to enable the output of the module
17	V1 ENABLE	Input	Enables or disables the output of V1	Must be connected to -SENSE pin or driven to <-0.7V to enable the output of the module
18	0SENSE	Input	Used for remote sense function to compensate for load bus resistance	If remote sensing is not required connect to OUTPUT pins 24-26 of the module

OUTPUT PINS

Pin No	Pin Name	Type	Description	Recommended Connections
21-22	+V1 OUTPUT	Output	Power output V1	Ensure good electrical connection and sufficient copper on PCB layouts
24-26	0	Output	Power output 0	
28-29	+V2 OUTPUT	Output	Power output V2	Ensure good electrical connection and sufficient copper on PCB layouts

AM80A-048L-050P25D033F30

CONTROL SIGNALS

Control Function	Conditions	Parameter	Min	Typ	Max	Units
TEMP MON - temperature monitor signal		V _{TMON} sensitivity	9.8	10	10.2	mV/°C
		Source impedance		2		KΩ
CMON - current monitor signal	I _O = I _{O rated}	I _{C MON}	0.9	1	1.1	mA
		Measured Range V1	5		25	A
		Measured Range V2	6		30	A
CSHARE - current share function*	CSHARE pins of modules in parallel connected	CSHARE accuracy		±3%	±10	%I _{O rated}
		Max no. of units			10	
CLK OUT - clock output	CLK IN open	V _{CLK OUT}	3.3		5.5	Vp-p
		Clock freq.	0.98	1	1.02	MHz
		Max fan out			2	
CLK IN - clock input		V _{CLK IN}	3.3		5.5	Vp-p
		Clock freq.	0.9	1	1.1	MHz
CLIM ADJ - current limit adjustment	V _{CLIM ADJ} = 0.8V	CLIM set point		20		%I _{O max}
	V _{CLIM ADJ} = 4.0V	CLIM set point		100		%I _{O max}
	V _{CLIM ADJ} = 1V	CLIM current source	0.95	1	1.05	mA
OVP ADJ ¹ - output overvoltage protection adjustment	V _{OVP ADJ} = 0V	OVP set point			150	%V _{O nom}
	V _{OVP ADJ} ≥ 1V	OVP set point	110			%V _{O nom}
	V _{OVP ADJ} = 1V	OVP ADJ current source	0.95	1	1.05	mA
VADJ - voltage adjust	V _{vadj} = 0V	V _O	78	80	82	%V _{O nom}
	V _{vadj} = 2V	V _O	118	120	122	%V _{O nom}
	V _{vadj} = 1V	VADJ current source	0.95	1	1.05	mA
ENABLE - module enable	Module enabled	V _{ENABLE}	0		0.7	V
	Module disabled	V _{ENABLE}	2		10	V
	V _{ENABLE} = 0.7V	ENABLE current source		100	150	μA

Notes :

1. OVP trip point must be adjusted to accommodate maximum remote sense compensation

Insulation - all models

INSULATION

Parameter	Conditions	Min	Typ	Max	Units
Input-output insulation resistance	500VDC	10			M Ω
Input-baseplate insulation resistance	500VDC	10			M Ω
Output-baseplate insulation resistance	500VDC	10			M Ω

Electrical Specifications for 48V Input Models (AM80A-048L-xxxFyy)

INPUT CHARACTERISTICS

Parameter	Conditions	Min	Typ	Max	Units
Input voltage		36	48	72	V
Input surge voltage	(continuous)			75	V
Input low line power on voltage	Module power on	30		35	V
Input low line power off voltage	Module shutdown	24		31.5	V
No load input power	$V_i = V_{Inom}$			5	W
Input capacitance				5	μ F
Input current	Low line, nom V_o , max I_o				
	AM80A-048L-012F60			3.3	A
	AM80A-048L-022F60			5.3	A
	AM80A-048L-033F50			6.2	A
	AM80A-048L-050F40			7.0	A
	AM80A-048L-120F18			7.5	A
	AM80A-048L-150F16			8.3	A
	AM80A-048L-240F10			8.2	A

TRANSIENT CHARACTERISTICS

Parameter	Conditions	Min	Typ	Max	Units
Turn-on time	$V_i = 0$ to V_{Inom}		1	10	ms ec
Transient response (25% to 75% load change @ 0.1A/ μ S, recovery to 1% V_o)	Step-load excursion				
	AM80A-048L-012F60		36	60	mV
	AM80A-048L-022F60		66	110	mV
	AM80A-048L-033F50		100	165	mV
	AM80A-048L-050F40		150	250	mV
	AM80A-048L-120F18		360	600	mV
	AM80A-048L-150F16		450	750	mV
	AM80A-048L-240F10		720	1200	mV
	Step-load response				
	AM80A-048L-012F60			400	μ S
AM80A-048L-022F60			400	μ S	
AM80A-048L-033F50			400	μ S	
AM80A-048L-050F40			400	μ S	
AM80A-048L-120F18			300	μ S	
AM80A-048L-150F16			250	μ S	
AM80A-048L-240F10			300	μ S	

Electrical Specifications for 48V Input Models (Cont'd)

OUTPUT CHARACTERISTICS

Parameter	Conditions	Min	Typ	Max	Units
Nominal (factory set) output voltage	AM80A -048L-012F60		1.2		V
	AM80A -048L-022F60		2.2		V
	AM80A -048L-033F50		3.3		V
	AM80A -048L-050F40		5.0		V
	AM80A -048L-120F18		12.0		V
	AM80A -048L-150F16		15.0		V
	AM80A -048L-240F10		24.0		V
Output voltage set point accuracy	$T_C = +25^\circ\text{C}$, $V_I = V_{Inom}$, $I_O = I_{Orated}$	-1		1	% V_{Onom}
Remote sense compensation	$V_I = V_{Imin}$			0.5	V
Output voltage adjust		80		120	% V_{Onom}
Nominal (factory set) output overvoltage protection trip point		110	115	120	% V_O
Overvoltage protection trim range		110		150	% V_O
Line regulation	V_{Imin} to V_{Imax} ; All models except: AM80A -048L-012F60 AM80A -048L-022F60 AM80A -048L-033F50			0.2	% V_{Onom}
				10	mV
				10	mV
				10	mV
Load regulation	I_{Omin} to I_{Omax} ; All models except: AM80A -048L-012F60 AM80A -048L-022F60 AM80A -048L-033F50			0.2	% V_{Onom}
				10	mV
				10	mV
				10	mV
Noise and ripple	20Mhz bandwidth AM80A -048L-012F60 AM80A -048L-022F60 AM80A -048L-033F50 AM80A -048L-050F40 AM80A -048L-120F18 AM80A -048L-150F16 AM80A -048L-240F10		50	100	mV
			50	100	mV
			50	100	mV
			50	100	mV
			120	240	mV
			240	300	mV
			240	480	mV
Output current	AM80A -048L-012F60	0		60	A
	AM80A -048L-022F60	0		60	A
	AM80A -048L-033F50	0		50	A
	AM80A -048L-050F40	0		40	A
	AM80A -048L-120F18	0		18	A
	AM80A -048L-150F16	0		16	A
	AM80A -048L-240F10	0		10	A
Output current limit	V_O dropped to 90% of V_{Onom}	105	110	115	% I_{Omax}
Short circuit current	AM80A -048L-012F60			160	% I_{Omax}
	AM80A -048L-022F60			160	% I_{Omax}
	AM80A -048L-033F50			160	% I_{Omax}
	AM80A -048L-050F40			160	% I_{Omax}
	AM80A -048L-120F18			200	% I_{Omax}
	AM80A -048L-150F16			200	% I_{Omax}
	AM80A -048L-240F10			200	% I_{Omax}
Temperature coefficient	Per $^\circ\text{C}$ Baseplate temperature			0.02	% $V_O/^\circ\text{C}$
Overtemperature shutdown	All models	105	110	120	$^\circ\text{C}$
Efficiency	$V_O = V_{Onom}$, $V_I = V_{Inom}$, $I_O = I_{Orated}$ AM80A -048L-012F60 AM80A -048L-022F60 AM80A -048L-033F50 AM80A -048L-050F40 AM80A -048L-120F18 AM80A -048L-150F16 AM80A -048L-240F10	60	64		%
		70	72		%
		75	80		%
		83	84		%
		85	87		%
		84	87		%
		85	88		%

Electrical Specifications for (AM80A-048L-050P25D033P30)

INPUT CHARACTERISTICS

Parameter	Conditions	Min	Typ	Max	Units
Input voltage		36	48	72	V
Input surge voltage	(1 second)			75	V
Input low line power on voltage	Module power on	30		35	V
Input low line power off voltage	Module shutdown	24		31.5	V
No load input power	$V_I = V_{Inom}$			5	W
Input capacitance				5	μ F
Input current	Low line, nom V_O , max I_O			8	A
Input current	Nom line, max V_O , max I_O			9.8	A

TRANSIENT CHARACTERISTICS

Parameter	Conditions	Min	Typ	Max	Units
Turn-on time	$V_I = 0$ to V_{Inom}		1	10	msec
Transient response (25% to 75% load change @ 0.1A/ μ S, recovery to 1% VO)	Step-load excursion			100	mV
	Step-load response			100	μ S

OUTPUT CHARACTERISTICS

Parameter	Conditions	Min	Typ	Max	Units
Nominal (factory set) output voltage	V1 050P25		5		V
	V2 033P30		3.3		V
Output voltage set point accuracy	$T_C = +25^\circ\text{C}$, $V_I = V_{Inom}$, $I_O = I_{Orated}$	-1		1	% V_{Onom}
Remote sense compensation	$V_I = V_{Imin}$			0.5	V
Output voltage adjust		80		120	% V_{Onom}
Nominal (factory set) output overvoltage protection trip point		110	115	120	% V_O
Overvoltage protection trim range		110		150	% V_{Onom}
Line regulation	V_{Imin} to V_{Imax}			0.2	% V_{Onom}
Load regulation	0 to I_{Omax}			0.2	% V_{Onom}
Noise and ripple	20MHz bandwidth		50	100	mV
Output current	V1 050P25	0		25	A
	V2 033P30	0		30	A
Output current limit	V_O dropped to 90% of V_{Onom}	105	110	115	% I_{Omax}
Short circuit current				160	% I_{Omax}
Temperature coefficient	Per $^\circ\text{C}$ Baseplate temperature			0.02	% $V_O/^\circ\text{C}$
Overtemperature shutdown	Baseplate temperature	87	95	105	$^\circ\text{C}$
Efficiency	$V_O = V_{Onom}$, $V_I = V_{Inom}$, $I_O = I_{Orated}$	80	83		%

Electrical Specifications for 150V Input Models (AM80A-150L-xxxFyy)

INPUT CHARACTERISTICS

Parameter	Conditions	Min	Typ	Max	Units
Input voltage		90	150	200	V
Input surge voltage	(1 second)			220	V
Input low line power on voltage	Module power on	75		88	V
Input low line power off voltage	Module shutdown	60		79	V
No load input power	$V_I = V_{Inom}$			5	W
Input capacitance				1.2	μ F
Input current	Low line, nom V_O , max I_O AM80A-150L-065F33			3	A
Input current	Nom line, max V_O , max I_O AM80A-150L-065F33			2.1	A

TRANSIENT CHARACTERISTICS

Parameter	Conditions	Min	Typ	Max	Units
Turn-on time	$V_I = 0$ to V_{Inom}		1	10	msec
Transient response (25% to 75% load change @ 0.1A/ μ S, recovery to 1% VO)	Step-load excursion AM80A-150L-065F33		195	325	mV
	Step-load response			250	μ S

OUTPUT CHARACTERISTICS

Parameter	Conditions	Min	Typ	Max	Units
Nominal (factory set) output voltage	AM80A-150L-065F33		6.5		V
Output voltage set point accuracy	$T_C = +25^\circ\text{C}$, $V_I = V_{Inom}$, $I_O = I_{Orated}$	-1		1	% V_{Onom}
Remote sense compensation ¹	$V_I = V_{Imin}$			0.5	V
Output voltage adjust		80		120	% V_{Onom}
Nominal (factory set) output overvoltage protection trip point		110	115	120	% V_O
Overvoltage protection trim range		110		150	% V_{Onom}
Line regulation	V_{Imin} to V_{Imax}			0.2	% V_{Onom}
Load regulation	0 to I_{Omax}			0.2	% V_{Onom}
Noise and ripple	20MHz bandwidth AM80A-150L-065F33		65	130	mV
Output current	AM80A-150L-065F33	0		33	A
Output current limit	V_O dropped to 90% of V_{Onom}	105	110	115	% I_{Omax}
Short circuit current	AM80A-150L-065F33			160	% I_{Omax}
Temperature coefficient	Per $^\circ\text{C}$ Baseplate temperature			0.02	% $V_O/^\circ\text{C}$
Overtemperature shutdown	Baseplate temperature	105	110	120	$^\circ\text{C}$
Efficiency	$V_O = V_{Onom}$, $V_I = V_{Inom}$, $I_O = I_{Orated}$ AM80A-150L-065F33	80	83		%

Electrical Specifications for 300V Input Models (AM80A-300L-xxxFyy)

INPUT CHARACTERISTICS

Parameter	Conditions	Min	Typ	Max	Units
Input voltage	All models - except :	180	300	400	V
	AM 80A-300L-065F33	240	300	400	V
	AM 80A-300L-280F09	200	300	400	V
Input surge voltage	(1 second)			425	V
Input low line power on voltage	Module power on	150		175	V
Input low line power off voltage	Module shutdown	120		157.5	V
No load input power	$V_I = V_{Inom}$			5	W
Input capacitance				0.5	μ F
Input current	Low line, nom V_O , max I_O				
	AM 80A-300L-022F60			1.1	A
	AM 80A-300L-033F50			1.3	A
	AM 80A-300L-050F40			1.4	A
	AM 80A-300L-065F33			1.5	A
	AM 80A-300L-120F18			1.5	A
	AM 80A-300L-150F16			1.6	A
	AM 80A-300L-240F10			1.6	A
	AM 80A-300L-280F09			1.6	A

TRANSIENT CHARACTERISTICS

Parameter	Conditions	Min	Typ	Max	Units
Turn-on time	$V_I = 0$ to V_{Inom}		1	10	msec
Transient response - (25% to 75% load change @ 0.1A/ μ S, recovery to 1% VO)	Step-load excursion				
	AM 80A-300L-022F60		66	110	mV
	AM 80A-300L-033F50		100	165	mV
	AM 80A-300L-050F40		150	250	mV
	AM 80A-300L-065F33		195	325	mV
	AM 80A-300L-120F18		360	600	mV
	AM 80A-300L-150F16		450	750	mV
	AM 80A-300L-240F10		720	1200	mV
	AM 80A-300L-280F09		700	1400	mV
Step load response				250	μ sec

Electrical Specifications for 300V Input Models (Cont'd)

OUTPUT CHARACTERISTICS

Parameter	Conditions	Min	Typ	Max	Units
Nominal (factory set) output voltage	A M 80A -300L-022F60		2.2		V
	A M 80A -300L-033F50		3.3		V
	A M 80A -300L-050F40		5.0		V
	A M 80A -300L-065F33		6.5		V
	A M 80A -300L-120F18		12.0		V
	A M 80A -300L-150F16		15.0		V
	A M 80A -300L-240F10		24.0		V
	A M 80A -300L-280F09		28.0		V
Output voltage set point accuracy	$T_C = +25^\circ\text{C}$, $V_I = V_{\text{Inom}}$, $I_O = I_{\text{O rated}}$	-1		1	% $V_{\text{O nom}}$
Remote sense compensation	$V_I = V_{\text{I min}}$			0.5	V
Output voltage adjust		80		120	% $V_{\text{O nom}}$
Nominal (factory set) output		110	115	120	% V_O
Overvoltage protection trip point					
Overvoltage protection trim range		110		150	% V_O
Line regulation	$V_{\text{I min}}$ to $V_{\text{I max}}$; All models except:			0.2	% $V_{\text{O nom}}$
	A M 80A -300L-022F60			10	mV
	A M 80A -300L-033F50			10	mV
Load regulation	$I_{\text{O min}}$ to $I_{\text{O max}}$; All models except:			0.2	% $V_{\text{O nom}}$
	A M 80A -300L-022F60			10	mV
	A M 80A -300L-033F50			10	mV
Noise and ripple	20M Hz band width				
	A M 80A -300L-022F60		50	100	mV
	A M 80A -300L-033F50		50	100	mV
	A M 80A -300L-050F40		50	100	mV
	A M 80A -300L-065F33		65	130	mV
	A M 80A -300L-120F18		120	240	mV
	A M 80A -300L-150F16		240	300	mV
	A M 80A -300L-240F10		240	480	mV
	A M 80A -300L-280F09		280	560	mV
Output current	A M 80A -300L-022F60	0		60	A
	A M 80A -300L-033F50	0		50	A
	A M 80A -300L-050F40	0		40	A
	A M 80A -300L-065F33	0		33	A
	A M 80A -300L-120F18	0		18	A
	A M 80A -300L-150F16	0		16	A
	A M 80A -300L-240F10	0		10	A
	A M 80A -300L-280F09	0		9	A
Output current limit	V_O dropped to 90% of $V_{\text{O nom}}$	105	110	115	% $I_{\text{O max}}$
Short circuit current	A M 80A -300L-022F60			160	% $I_{\text{O max}}$
	A M 80A -300L-033F50			160	% $I_{\text{O max}}$
	A M 80A -300L-050F40			160	% $I_{\text{O max}}$
	A M 80A -300L-065F33			165	% $I_{\text{O max}}$
	A M 80A -300L-120F18			200	% $I_{\text{O max}}$
	A M 80A -300L-150F16			200	% $I_{\text{O max}}$
	A M 80A -300L-240F10			200	% $I_{\text{O max}}$
	A M 80A -300L-280F09			200	% $I_{\text{O max}}$
Temperature coefficient	Per $^\circ\text{C}$ Baseplate temperature			0.02	% $V_O/^\circ\text{C}$
Overtemperature shutdown	Baseplate temperature	105	110	120	$^\circ\text{C}$
Efficiency	$V_O = V_{\text{O nom}}$, $V_I = V_{\text{Inom}}$, $I_O = I_{\text{O rated}}$				
	A M 80A -300L-022F60	70	74		%
	A M 80A -300L-033F50	75	78		%
	A M 80A -300L-050F40	82	83		%
	A M 80A -300L-065F33	83	85		%
	A M 80A -300L-120F18	84	86		%
	A M 80A -300L-150F16	82	86		%
	A M 80A -300L-240F10	84	87		%
	A M 80A -300L-280F09	85	87		%

Electrical Specifications for 320V Input Models (AM80A-320L-xxxFyy)

INPUT CHARACTERISTICS

Parameter	Conditions	Min	Typ	Max	Units
Input voltage		256	320	400	V
Input surge voltage	(1 second)			425	V
Input low line power on voltage	Module power on	200		230	V
Input low line power off voltage	Module shutdown	160		205	V
No load input power	$V_I = V_{Inom}$			5	W
Input capacitance				0.5	μ F
Input current	Low line, nom V_O , max I_O AM80A-320L-280F09			1.2	A

TRANSIENT CHARACTERISTICS

Parameter	Conditions	Min	Typ	Max	Units
Turn-on time	$V_I = 0$ to V_{Inom}		1	10	msec
Transient response (25% to 75% load change @ 0.1A/ μ S, recovery to 1% VO)	Step-load excursion AM80A-320L-280F09		700	1400	mV
	Step-load response			800	μ S

OUTPUT CHARACTERISTICS

Parameter	Conditions	Min	Typ	Max	Units
Nominal (factory set) output voltage	AM80A-320L-280F09		28		V
Output voltage set point accuracy	$T_C = +25^\circ\text{C}$, $V_I = V_{Inom}$, $I_O = I_{Orated}$	-1		1	% V_{Onom}
Remote sense compensation	$V_I = V_{Imin}$			0.5	V
Output voltage adjust		80		120	% V_{Onom}
Nominal (factory set) output overvoltage protection trip point		110	115	120	% V_O
Overvoltage protection trim range		110		150	% V_{Onom}
Line regulation	V_{Imin} to V_{Imax}			56	mV
Load regulation	0 to I_{Omax}			56	mV
Noise and ripple	20MHz bandwidth AM80A-320L-280F09			375	mV
Output current	AM80A-320L-280F09	0		9	A
Output current limit	V_O dropped to 90% of V_{Onom}	105	110	115	% I_{Omax}
Short circuit current	AM80A-320L-280F09			200	% I_{Omax}
Temperature coefficient	Per $^\circ\text{C}$ Baseplate temperature			0.02	% $V_O/^\circ\text{C}$
Overtemperature shutdown	Baseplate temperature	102	105	108	$^\circ\text{C}$
Efficiency	$V_O = V_{Onom}$, $V_I = V_{Inom}$, $I_O = I_{Orated}$ AM80A-320L-280F09	86	88		%

Functional Description

This section explains how to implement the functions found on the AM80A Performance Series. The pin assignment shown in the diagram below does not apply to AM80A-048L-050P25D033P30.

Remote Sense (+SENSE, -SENSE)

Connect the +SENSE and -SENSE pins of the AM80A directly to the load to allow the module to compensate for the voltage drop across the conductors carrying the load current. If remote sensing is not required (for example if the load is close to the module) the sense pins should be connected directly to the module's output pins to ensure accurate regulation.

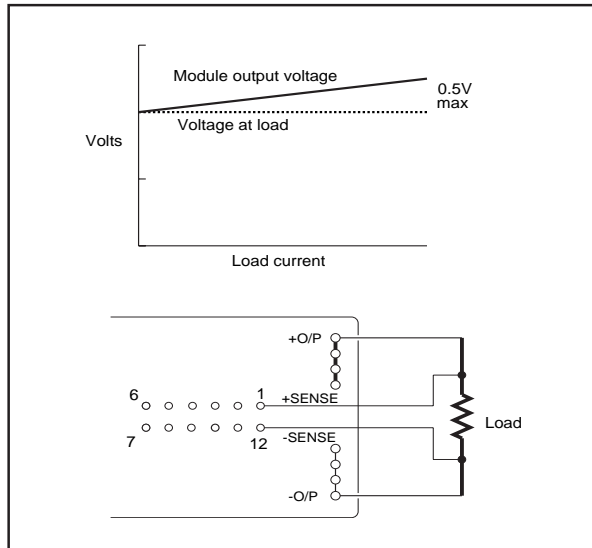

Note: If the sense leads fail open circuit, the module will revert to local sense at the output pins. Incorrect connection of sense leads may damage the module

Enable Control (ENABLE)

The enable pin is a TTL compatible input used to turn the output of the module on or off. The module output is enabled when the ENABLE pin is connected to -SENSE or driven to a logic low of $<0.7V$ (but not negative).

The output is disabled when the enable pin is open or driven to a logic high $>2V$. All monitoring and house-keeping functions (including clock signals) continue to operate normally.

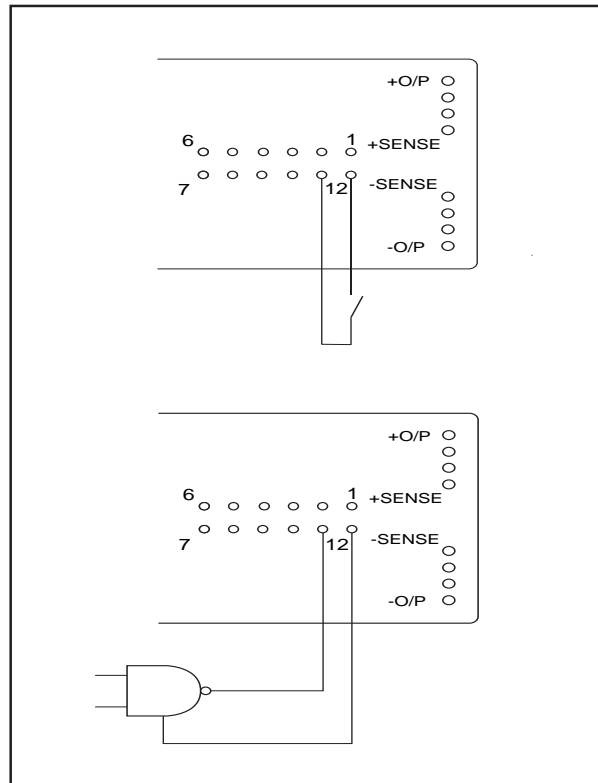

Output Voltage Adjustment (V ADJ)

The output voltage of the module may be accurately adjusted by up to $\pm 20\%$ of the nominal factory set output. Adjustment is carried out using either an external voltage source (0 to 2V, capable of sinking 1mA) or a resistor (0 to 2K) connected between V ADJ and -SENSE.

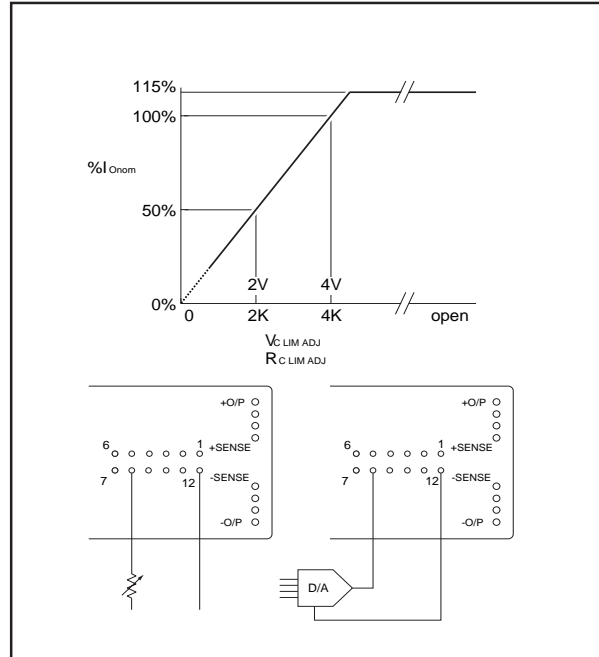
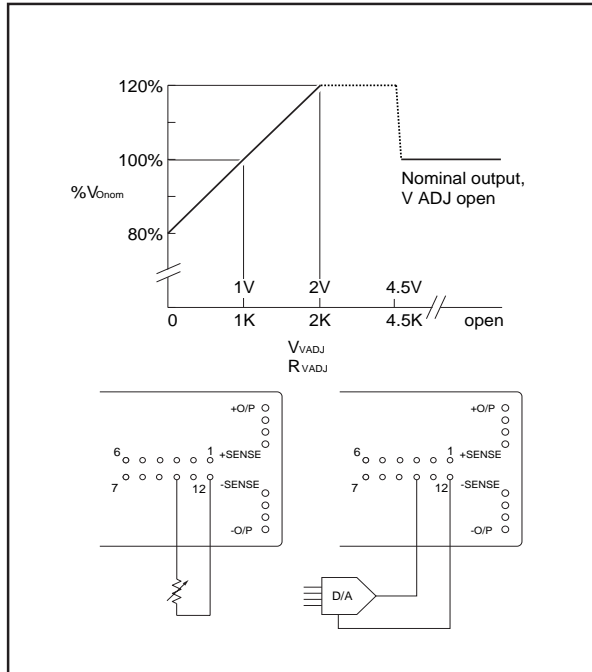

Overvoltage Protection Adjustment (OVP ADJ)

An independent overvoltage circuit monitors the module's output pins and will shut the module down in the event of an internal or external fault which causes the output voltage to rise above the preset limit. The module is reset by removing and re-applying the input power or toggle the ENABLE OFF/ON.

Current Limit Adjustment (C LIM ADJ)

A constant current limiting circuit protects the module under overload or short circuit conditions. With the C LIM ADJ pin left unconnected the current limit is factory set to 115% of the module's rated output, but may be adjusted across the range from 20% to 100% using an external voltage source (0.8 to 4V, capable of sinking 1mA) or a resistor (800R to 4K) connected between CLIM ADJ and -SENSE.

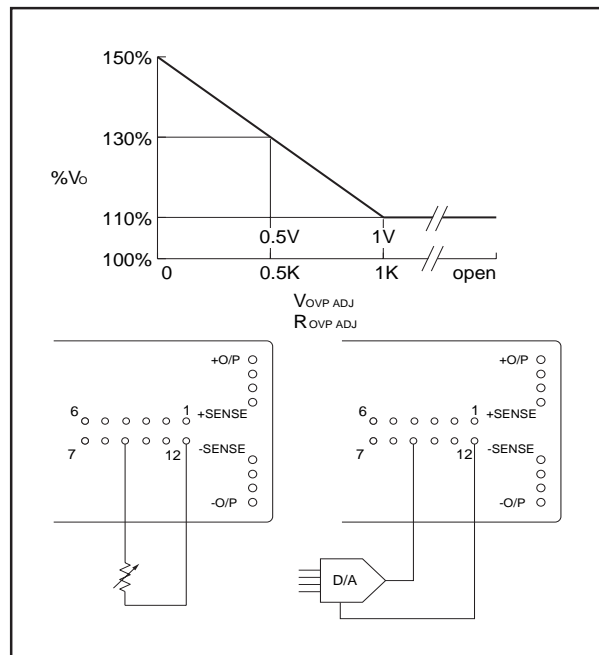

The overvoltage set point may be adjusted between 10% and 50% above the output voltage (V_o), and automatically tracks adjustments made to the output voltage using V ADJ.

OVP ADJ should be used to increase the OVP margin if the voltage drop between power output pins and remote sense is more than 0.2V

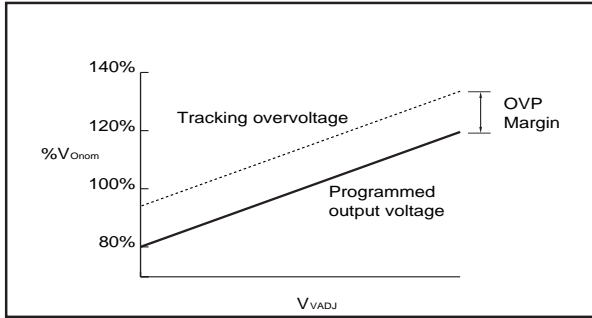

Power Good/Identification (PG/ID)

(Not apply to AM80A-048L-050P25D033P30)
This pin provides an indication that the module's converters are working, and can also be used to identify the factory set output voltage of the module.

The PG/ID pin goes high to the level of the output voltage (V_o) to indicate that the module is operating and delivering power. The output goes low if the converters stop operating due to a fault such as an overtemperature or overvoltage condition. The PG/ID pin will also go low if the module is disabled via the ENABLE pin or under light load condition (seespecification).

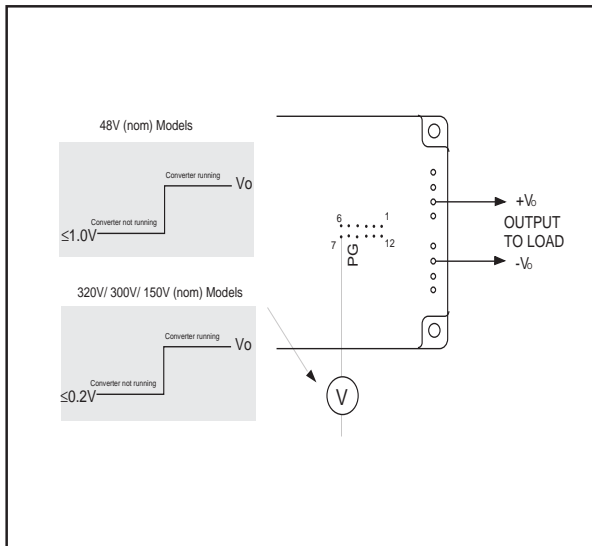

The resistance between the PG/ID pin and the +ve output of the module can be used to determine the output voltage of the module with no power applied according to the table:

Output Voltage (V)	Resistance (K Ω)
1.2	1.2
2.2	2.2
6.5	6.8
3.3	3.3
5	5.1
12	12
15	15
24	24
28	27

Clock Signals (CLK IN, CLK OUT)

The module's internal clock is accurate and stable over its full operating range and synchronization is not normally required, but it can reduce noise in paralleled systems.

Clock signals can be wired in series (the CLK OUT pin of one module to the CLK IN pin of the next etc) in which case all the modules will be synchronized with the first module in the chain. Alternatively, an external clock signal of 5Vpk-pk at 1MHz \pm 10% can be connected to the CLK IN pins of all the modules.

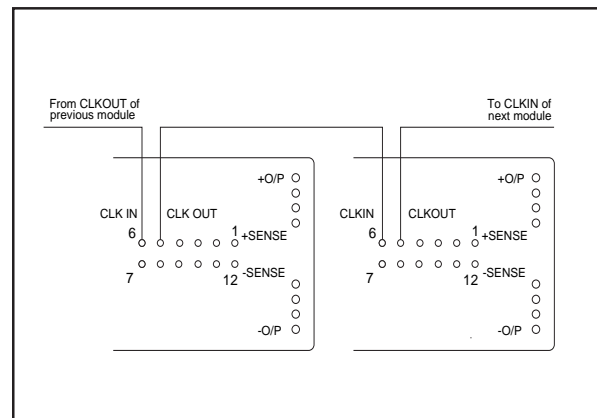

If the clock input to any module fails, the module will automatically switch back to its internal clock and will continue to operate normally. The CLK IN and CLK OUT signals are AC coupled, so any module can clock another module regardless of polarity.

Current Sharing (C SHARE)

To ensure that all modules in a parallel system accurately share current, the C SHARE pins on each module should be connected together.

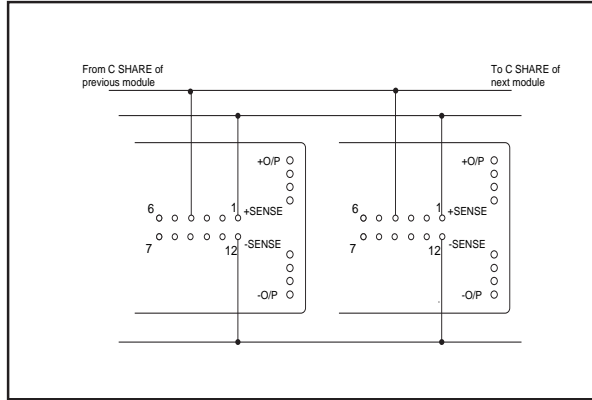

The voltage on the C SHARE pins represents the average load current per module. Each module compares this average with its own current and adjusts its output voltage to correct the error. In this way the module maintains accurate current sharing.

Note: The *-SENSE* and *+SENSE* pins of each module must also be connected together to ensure accurate current sharing.

Current Monitoring (C MON)

The C MON pin provides an indication of the amount of current supplied by the module. The output of the C MON pin is a current source proportional to the

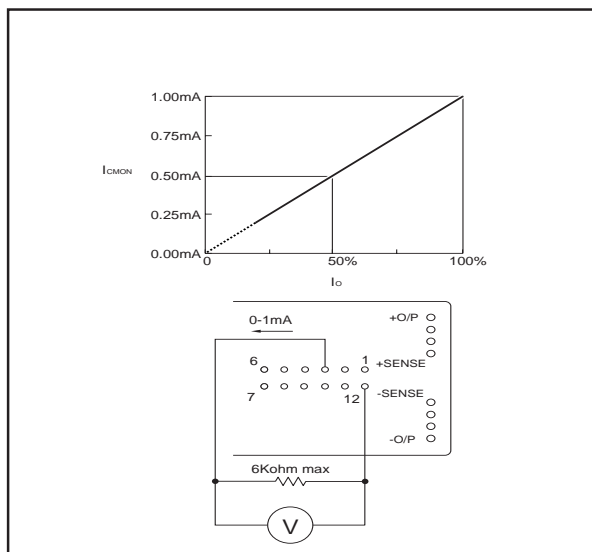

output current of the module, where $0.2 \text{ to } 1 \text{ mA} = 20 \text{ to } 100\% I_{O \text{ rated}}$. The C MON output can be paralleled with C MON outputs from other modules to indicate the total current supplied in a paralleled system.

Temperature Monitoring (TEMP MON)

The TEMP MON pin provides an indication of the module's internal temperature. The voltage at the TEMP MON pin is proportional to the temperature of the module baseplate at 10mV per °C, where:

$$\text{Module temperature (}^\circ\text{C)} = (V_{\text{TEMP MON}} \times 100) - 273$$

The temperature monitor signal can be used by thermal management systems (e.g. to control a variable speed fan). It can also be used for overtemperature warning circuits and for thermal design verification of prototype power supplies and heatsinks.

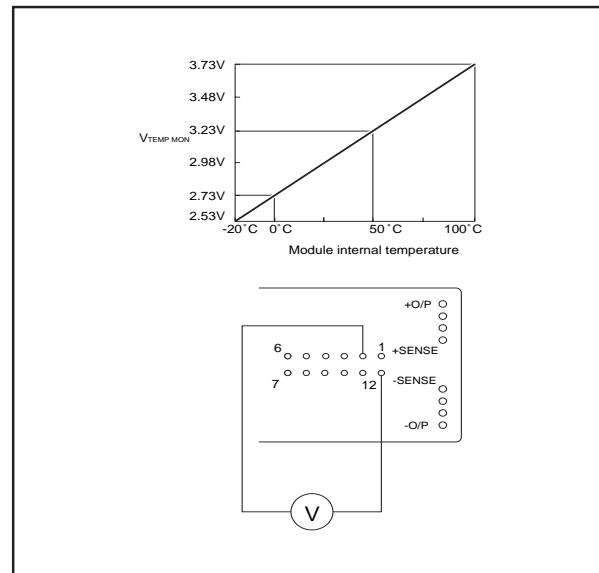

Design Considerations

Input Bulk Capacitors

Electrolytic bulk reservoir capacitors placed close to the module input pins are recommended to ensure the module is fed with a low source impedance. For the AM80A Performance Series module typical values are 220 μ F/100V for 48V modules and 220 μ F/450V for 300/320V modules.

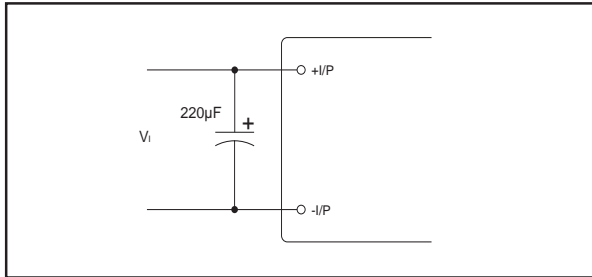

Input Fusing

AMPSS modules do not have an in-line fuse fitted internally. In order to comply with CSA, VDE and UL safety regulations it is recommended that a fuse of the following rating be fitted at the module's input.

Input	Fuse Rating
300V/320V	10A / 250V
150V	10A / 250V
48V	10A / 250V

Remote Loads

If the sensed load is some distance from the module, the module's output voltage may rise sufficiently to trigger the OVP protection circuit during a step load change due to bus inductance. For this reason the OVP margin should be increased in extreme cases. Fitting a decoupling capacitor at the load can reduce this effect.

It should be noted that a distributed power solution, using AMPSS™ modules placed close to their loads, will optimize transient response.

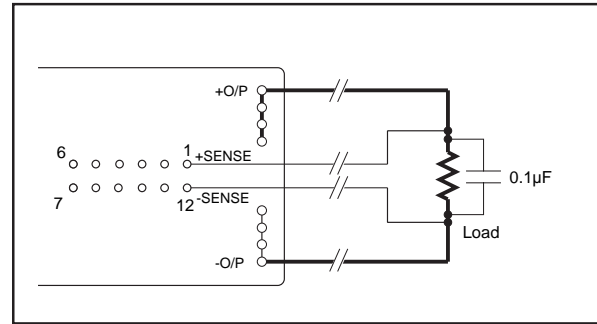

Thermal Data

Natural convection thermal impedance of the AM80A package without a heatsink is approximately 4°C/W. The below characteristic is for a standard horizontal fin heatsink available from Astec (part number APA501-80-002) with 11mm fins and 8mm pitch. The heatsink will reduce module thermal impedance to 1°C/W with a forced air flow of 250 LFM when mounted with a thermal pad (ASTEC P/N APA502-80-001) between heatsink and module.

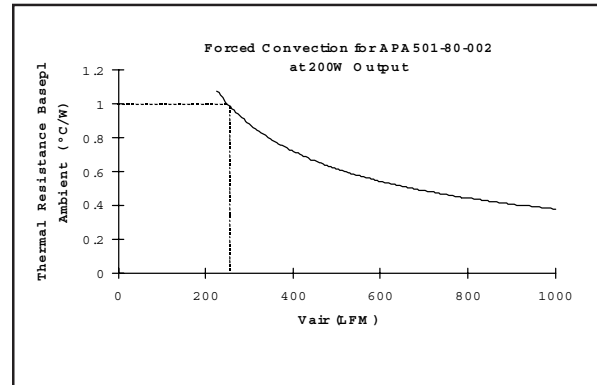

Overtemperature Protection

If the module's baseplate temperature exceeds 110°C, the module will latch OFF. To reset the module the input supply or the enable pin of the module must be cycled off and then on again, allowing a period of time for the module to cool down.

Overtemperature shutdown can also be programmed to occur at lower temperatures by using the TEMP MON output to control the ENABLE pin.

Parallel Connection Considerations

A master-slave configuration is not required for AMPSS™ modules. AM80A modules may be connected in parallel using a simple, single wire connection.

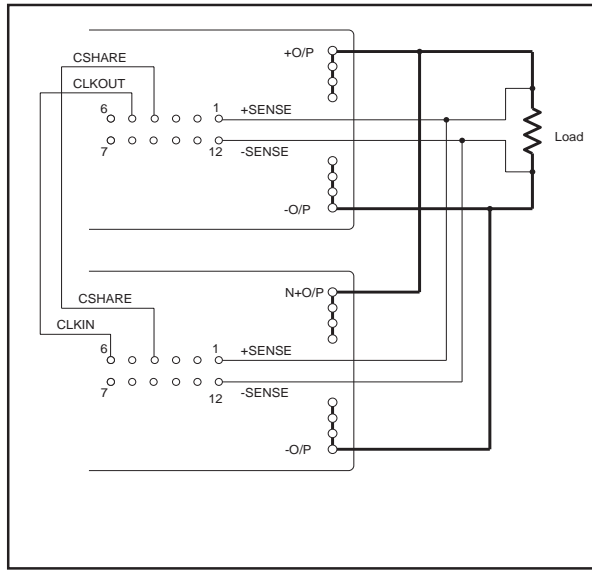

Current Sharing

In multi-module paralleled systems, all modules will share current to within $\pm 3\%$ (typical) of the rated load current per module when the C SHARE pins of each module are connected together. The +SENSE and -SENSE pins of each module should be connected to common points as close as possible to the load.

Synchronization

Modules are synchronized by connecting the CLK OUT pin of one module to the CLK IN pin of the next. Consecutively connected modules operate out of phase with each other, resulting in ripple cancellation at the inputs and outputs of paralleled modules. If the clock input to a module fails, it will automatically revert to its internal clock and continue to operate normally.

Output Ripple and Noise

AM80A Performance Series modules are designed to generate very low ripple and noise. When mounted on logic boards, for example, sufficient decoupling is normally provided by the components used to decouple the logic ICs, and no additional decoupling is required.

Conducted EMI

Although AMPSS modules contain both common mode and differential mode input EMI filtering, power supply systems using these modules will require additional EMI filtering to enable the system to meet relevant EMI standards.

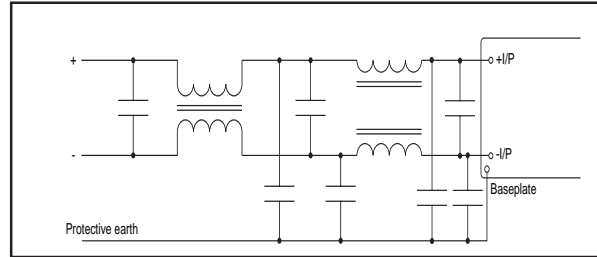

AM80A modules have an effective input to ground (baseplate) capacitance of 700pF for 300V input models and 580pF for 48V input models. This should be accounted for when calculating the maximum EMI 'Y' capacitance to meet ground leakage current specifications.

Break Regulation

AM80A Performance Series modules are designed to deliver full rated output current at up to 0.5V above $V_{O\text{nom}}$ at the minimum specified input voltage.

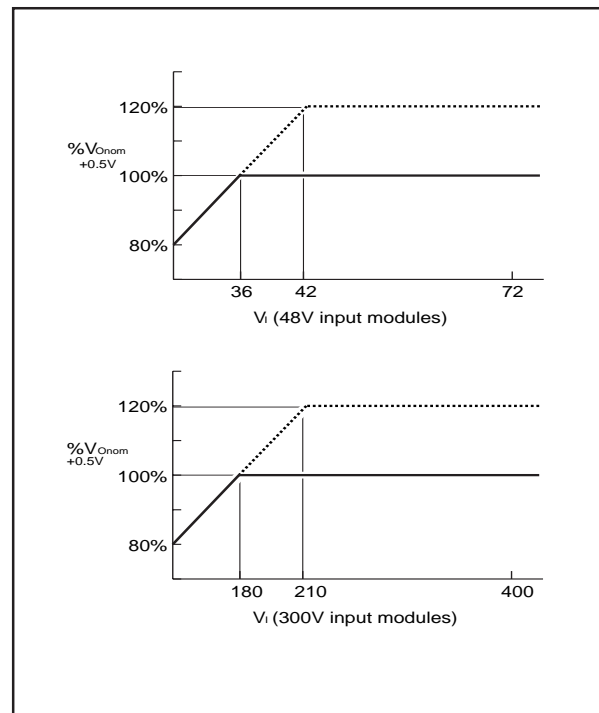

Input Undervoltage Protection

An input undervoltage protection circuit protects the module under low input voltage conditions. Hysteresis is built into the AM80A Performance Series module to allow for high levels of ripple on the input supply voltage without causing the module to cycle on and off. Typically 320V modules will turn on when the input exceeds 220V and turn off below 180V. 300V modules will turn on when the input exceeds 160V and turn off below 140V. 48V modules will turn on above 33V and turn off below 28V (see Electrical Specifications for exact figures).

Application Examples

AC Input Design

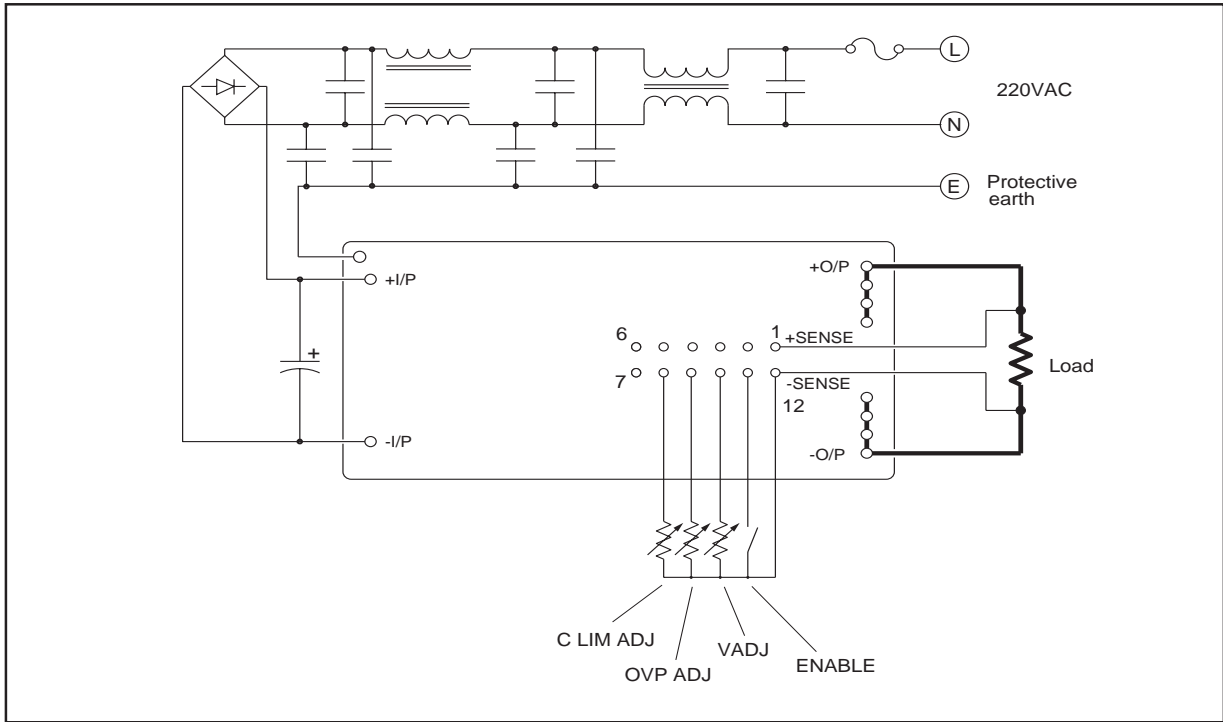

Parallel Connection Design

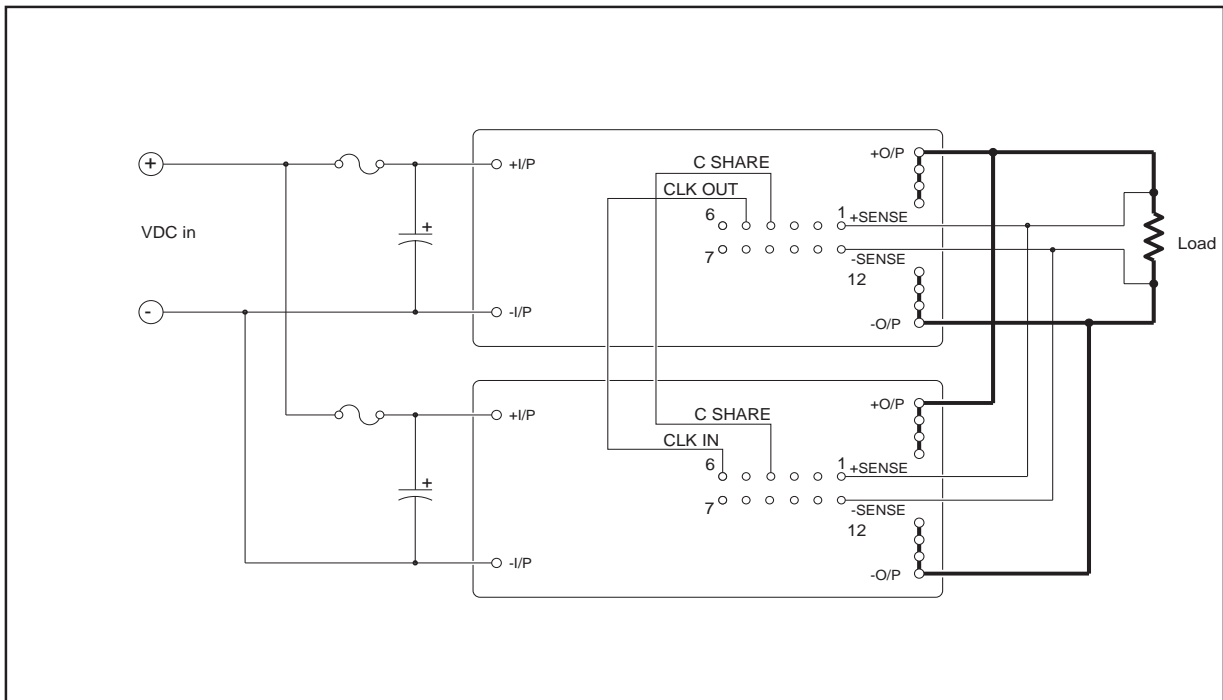

Mechanical Information Single Output Module

Dimensions

The dimensions are given in mm (inches). Note that the baseplate must be connected to protective earth before power is supplied to the module.

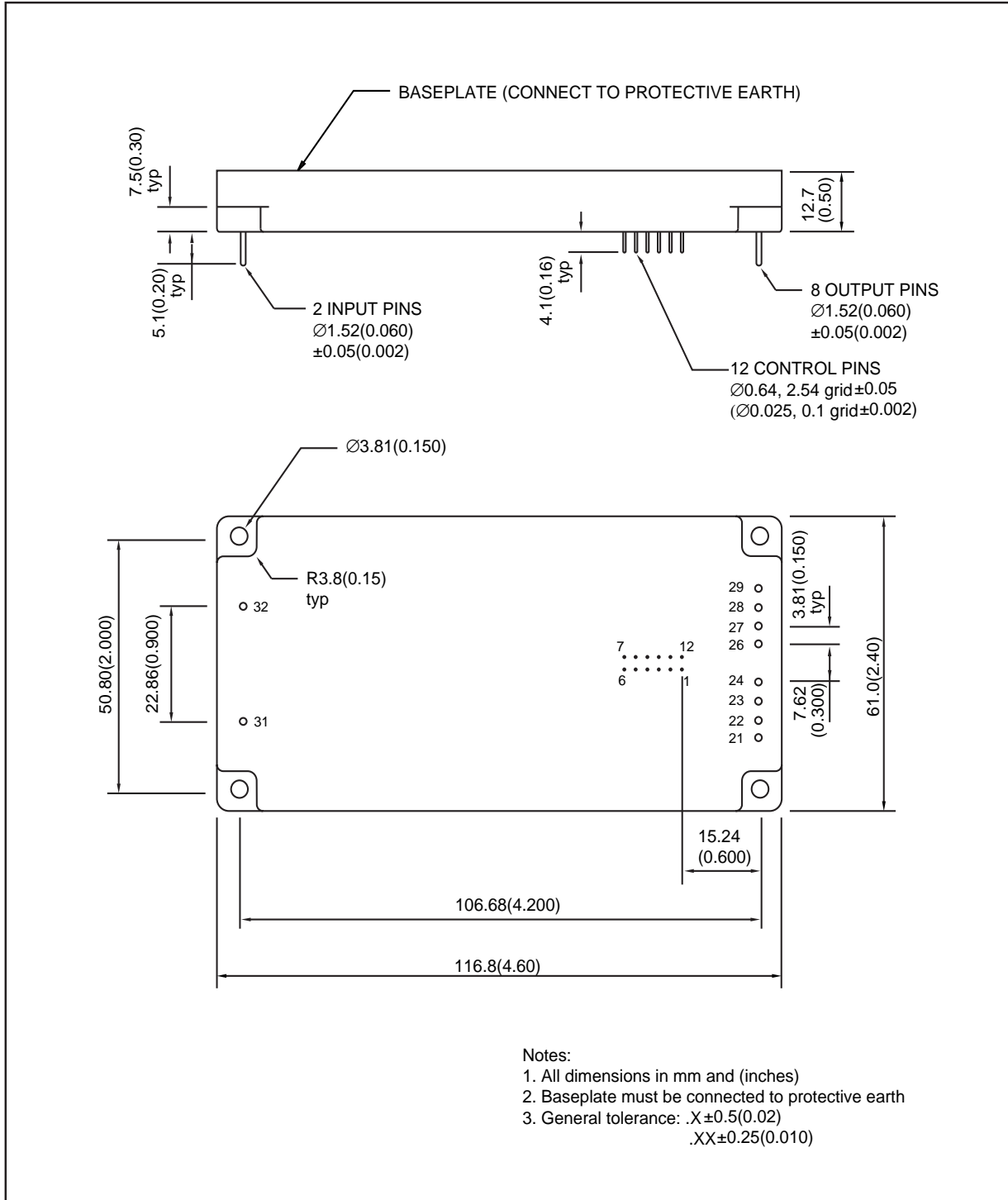

Recommended PCB Layout Single Output Module

The AM80A Performance Series module may be mounted to a board either by soldering or by using spring sockets.

Control pins are tin plated phospher-bronze.
Input and output pins are tin plated copper.

Materials :

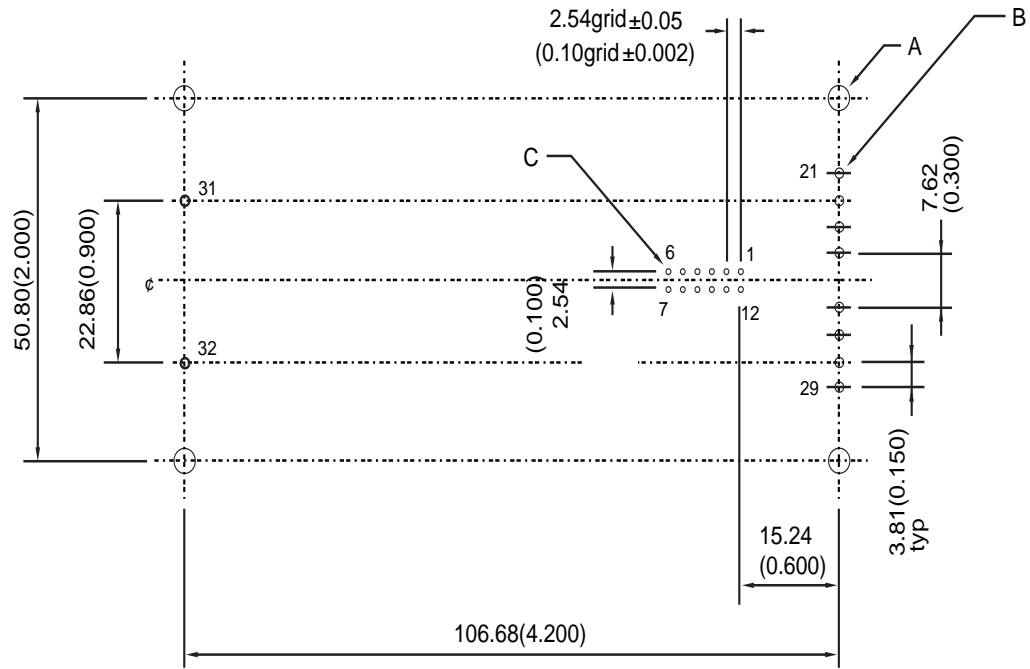

VIEW FROM PCB COMPONENT SIDE

NOTES:

1. PCB COMPONENT SIDE VIEW IS SHOWN.
2. ALL DIMENSIONS IN mm AND (INCHES).
3. GENERAL TOLERANCE: .XX±0.1(0.006).

RECOMMENDED HOLE SIZE TABLE: -

	A	B	C
HOLE SIZE FOR PCB DIRECT SOLDERING	Ø2.00+0.15/-0 (Ø0.079+0.006/-0)	Ø2.00+0.15/-0 (Ø0.079+0.006/-0)	Ø1.00+0.15/-0 (Ø0.039+0.006/-0)
HOLE SIZE FOR SPRING SOCKET MOUNTING*	/	Ø2.67±0.05 (Ø0.105 ±0.002)	Ø1.37±0.05 (Ø0.054 ±0.002)
HOLE SIZE FORM 3.5 MACHINE SCREW	Ø4.5+0.08/-0 (Ø0.177+0.0031/-0) FORM3.5	/	/

*Spring sockets are available from Astec in packs of 20 control pin sockets and 15 power pin sockets, part no. APA504-00-001. Sockets are not suitable for output current greater than 10A per pin.

Mechanical Information

Dimensions of AM80A-048L-050P25D033P30

The dimensions are given in mm (inches). Note that the baseplate must be connected to protective earth before power is supplied to the module.

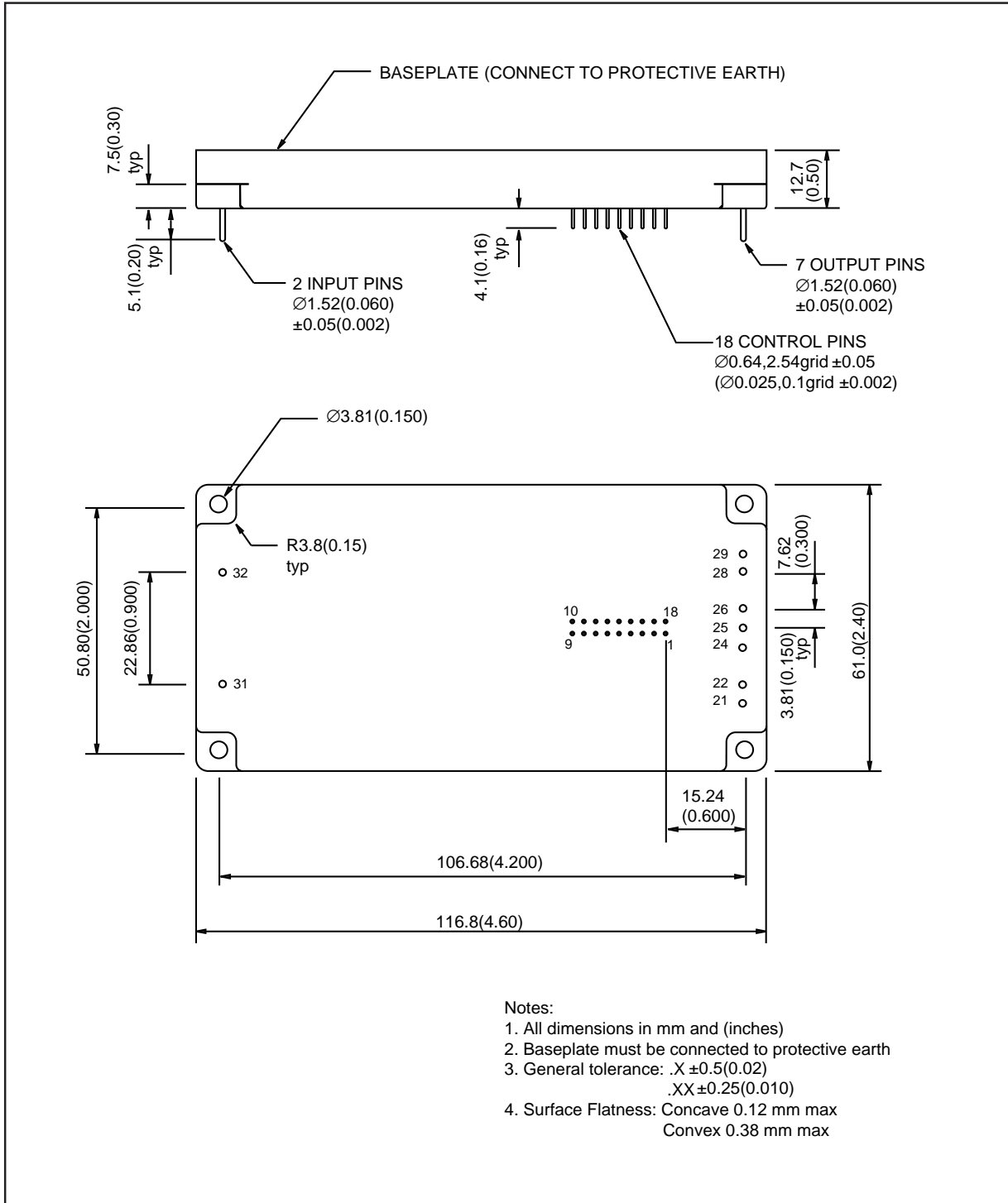

Recommended PCB Layout

The AM80A-048L-050P25D033P30 module may be mounted to a board either by soldering or by using spring sockets.

Materials :
Control pins are tin plated phospher-bronze.
Input and output pins are tin plated copper.

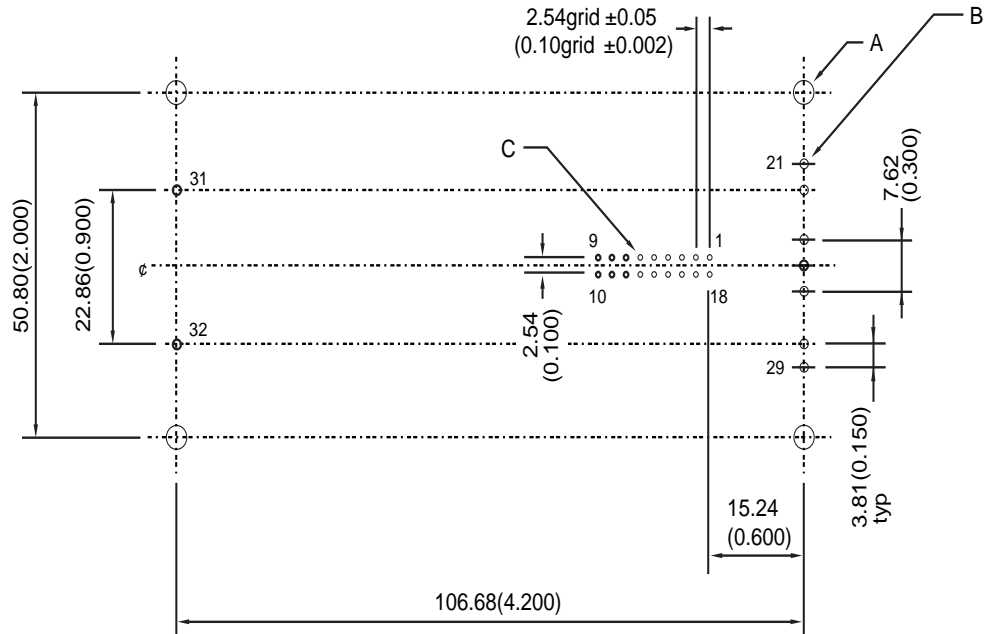

VIEW FROM PCB COMPONENT SIDE

- NOTES:
1. PCB COMPONENT SIDE VIEW IS SHOWN.
 2. ALL DIMENSIONS IN mm AND (INCHES).
 3. GENERAL TOLERANCE: .XX ±0.1(0.006).

RECOMMENDED HOLE SIZE TABLE: -

	A	B	C
HOLE SIZE FOR PCB DIRECT SOLDERING	∅2.00+0.15/-0 (∅0.079+0.006/-0)	∅2.00+0.15/-0 (∅0.079+0.006/-0)	∅1.00+0.15/-0 (∅0.039+0.006/-0)
HOLE SIZE FOR SPRING SOCKET MOUNTING*		∅2.67 ±0.05 (∅0.105 ±0.002)	∅1.37 ±0.05 (∅0.054 ±0.002)
HOLE SIZE FORM 3.5 MACHINE SCREW	∅4.5+0.08/-0 (∅0.177+0.0031/-0) FORM3.5		

*Spring sockets are available from Astec in packs of 20 control pin sockets and 15 power pin sockets, partno. APA504-00-001. Sockets are not suitable for output current greater than 10A per pin.

Heatsink Mounting Information

Heatsinks for AMPSS™ modules are available in a variety of sizes and fin orientation. Mounting kits and thermal pads are also available. The table below shows the options available for AM80A Performance Series.

A heatsink mounting kit provides the most convenient way to mount the heatsink to the module and then mount the assembly onto a circuit board

AMPSS™ modules may be retained by their input and output pins only, or may be fixed to the board th cases the studs provide clearance between the module and the circuit board to facilitate PCB cleaning operations.

- Note:* 1) Baseplate and heatsink must be connected to protective earth.
 2) Mechanical support must not induce twist in the module baseplate and must incorporate strain relief, e.g. spring washers.

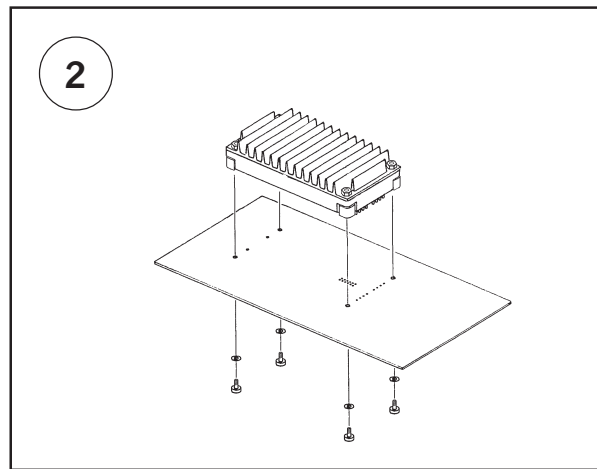
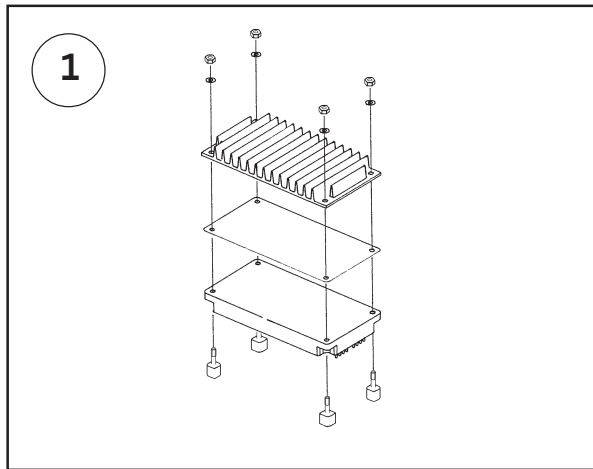

Description	Model Number	Dimensions		Free air thermal resistance
		inches	mm	
Heatsink, "80" size, vertical fin.	APA501-80-001	4.53x2.32x0.6	115x59x15	2.7°C/W
Heatsink, "80" size, horizontal fin	APA501-80-002	4.53x2.32x0.6	115x59x15	2.4°C/W
Heatsink, "80" size, vertical fin.	APA501-80-003	4.53x2.32x0.9	115x59x22.5	2.2°C/W
Heatsink, "80" size, horizontal fin	APA501-80-004	4.53x2.32x0.9	115x59x22.5	2.0°C/W
Heatsink, "80" size, vertical fin.	APA501-80-005	4.53x2.32x1.5	115x59x37	2.0°C/W
Heatsink, "80" size, horizontal fin	APA501-80-006	4.53x2.32x1.5	115x59x37	1.7°C/W
Heatsink, "80" size, low profile	APA501-80-007	4.55x3.50x0.5	115.6x89x12	2.2°C/W
Thermal Pad, "80" size	APA502-80-001			
Mounting Kit, Tapped Studs	APA503-00-001			
Mounting Kit, Solder Studs	APA503-00-002			
Mounting Kit, Tapped Studs for low profile heatsink	APA503-00-007			
Mounting Kit, Solder Studs for low profile heatsink	APA503-00-008			
Spring Sockets (20 cont. 15pwr)	APA504-00-001			

To provide optimal thermal contact between heatsink and module, it is recommended that the mating surface of the heatsink should have a surface flatness of no greater than 0.1mm. The use of a thermal pad or thermal grease is also recommended.

The recommended torque of using AMPSS mounting kit for module/heatsink is:

Screw size	Torque
M3	4-6kg-cm (3.5-5.2 lb-in)
M3.5	6-8kg-cm (5.2-6.9 lb-in)

Torque sequence:

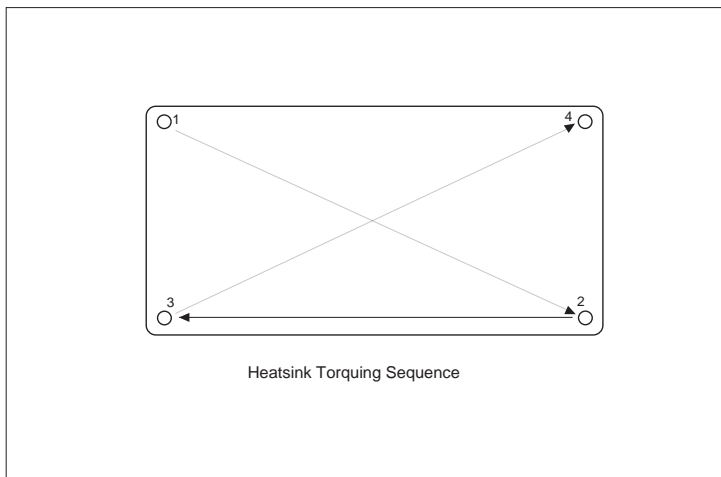

It is assumed that all four mounting screws are being torqued to a common surface.

Other thermal management schemes are at customer discretion as long as the maximum thermal rating of the specific module is not exceeded.

For further information contact :

NORTHAMERICA

ASTEC AMERICA, INC.,
5810 Van Allen Way,
Carlsbad CA 92008,
USA.
Tel: 760-930-4600
Fax: 760-930-0698

EUROPE

ASTECEUROPE LTD.
Astec House, Unit 9,
Waterfront Business Park,
Merry Hill, Dudley
DY5 1LX
U.K.
Tel: 01384-842211
Fax: 01384-843355

ASIA

ASTEC AGENCIES LIMITED
Unit 2111-2116, Level 21
223, Hing Fong Road
Kwai Fong
N.T.
Hong Kong
Tel: 8522437-9662
Fax: 8522402-4426

