

Three Phase Rectifier Bridge

 $I_{dAV} = 63/88 \text{ A}$
 $V_{RRM} = 800-1800 \text{ V}$

V_{RSM} V	V_{RRM} V	Type
600	600	VUO 62-06NO7 VUO 82-06NO7
800	800	VUO 62-08NO7 VUO 82-08NO7
1200	1200	VUO 62-12NO7 VUO 82-12NO7
1400	1400	VUO 62-14NO7 VUO 82-14NO7
1600	1600	VUO 62-16NO7 VUO 82-16NO7
1800	1800	VUO 62-18NO7* VUO 82-18NO7*

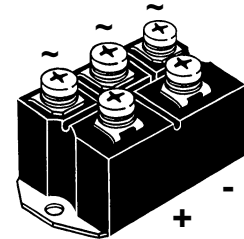
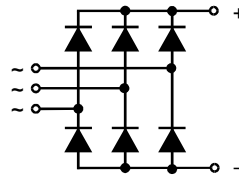

* delivery time on request

Symbol	Test Conditions	Maximum Ratings			
		VUO 62	VUO 82		
I_{dAV}	$T_C = 110^\circ\text{C}$, module	63	88	A	
I_{dAV}	$T_A = 45^\circ\text{C}$ ($R_{thCA} = 0.6 \text{ K/W}$), module	48	57	A	
I_{FSM}	$T_{VJ} = 45^\circ\text{C}$; $V_R = 0$	$t = 10 \text{ ms}$ (50 Hz), sine	550	750	A
		$t = 8.3 \text{ ms}$ (60 Hz), sine	600	820	A
I_{t}	$T_{VJ} = 45^\circ\text{C}$; $V_R = 0$	$t = 10 \text{ ms}$ (50 Hz), sine	1520	2800	A ² s
		$t = 8.3 \text{ ms}$ (60 Hz), sine	1520	2800	A ² s
I_{t}	$T_{VJ} = T_{VJM}$; $V_R = 0$	$t = 10 \text{ ms}$ (50 Hz), sine	1250	2250	A ² s
		$t = 8.3 \text{ ms}$ (60 Hz), sine	1250	2250	A ² s
T_{VJ}		-40...+150		$^\circ\text{C}$	
T_{VJM}		150		$^\circ\text{C}$	
T_{stg}		-40...+125		$^\circ\text{C}$	
V_{ISOL}	50/60 Hz, RMS	$t = 1 \text{ min}$	2500	V~	
	$I_{ISOL} \leq 1 \text{ mA}$	$t = 1 \text{ s}$	3000	V~	
M_d	Mounting torque (M5)		$5 \pm 15 \%$	Nm	
	Terminal connection torque (M5)		$5 \pm 15 \%$	Nm	
Weight	typ.		160	g	

Features

- Package with screw terminals
- Isolation voltage 3000 V~
- Planar passivated chips
- Blocking voltage up to 1800 V
- Low forward voltage drop
- UL registered E72873

Applications

- Supplies for DC power equipment
- Input rectifiers for PWM inverter
- Battery DC power supplies
- Field supply for DC motors

Advantages

- Easy to mount with two screws
- Space and weight savings
- Improved temperature and power cycling

Dimensions in mm (1 mm = 0.0394")

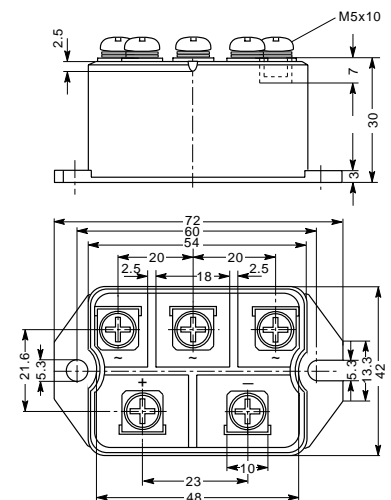

Symbol	Test Conditions	Characteristic Values		
		VUO 62	VUO 82	
I_R	$V_R = V_{RRM}$; $T_{VJ} = 25^\circ\text{C}$	≤ 0.3	0.3	mA
	$V_R = V_{RRM}$; $T_{VJ} = T_{VJM}$	≤ 5	5	mA
V_F	$I_F = 150 \text{ A}$; $T_{VJ} = 25^\circ\text{C}$	≤ 1.8	1.6	V
V_{T0}	For power-loss calculations only	0.8	0.8	V
r_T		8	5	m Ω
R_{thJC}	per diode	1.45	1.1	K/W
	per module	0.24	0.183	K/W
R_{thJH}	per diode	1.87	1.52	K/W
	per module	0.31	0.253	K/W
d_S	Creeping distance on surface		10	mm
d_A	Creepage distance in air		9.4	mm
a	Max. allowable acceleration		50	m/s ²

Data according to IEC 60747 and refer to a single diode unless otherwise stated.
 IXYS reserves the right to change limits, test conditions and dimensions.