

International
IR Rectifier

203CNQ100PbF

SCHOTTKY RECTIFIER

200 Amp

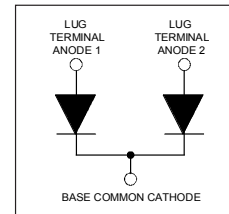

Major Ratings and Characteristics

Characteristics	Value	Units
$I_{F(AV)}$ Rectangular waveform	200	A
V_{RRM}	100	V
I_{FSM} @tp = 5 μ s sine	12,800	A
V_F @100Apk, $T_J=125^\circ\text{C}$ (per leg)	0.70	V
T_J range	-55 to 175	$^\circ\text{C}$

Description/ Features

The 203CNQ.. center tap Schottky rectifier module series has been optimized for low reverse leakage at high temperature. The proprietary barrier technology allows for reliable operation up to 175 $^\circ\text{C}$ junction temperature. Typical applications are in high current switching power supplies, plating power supplies, UPS systems, converters, free-wheeling diodes, welding, and reverse battery protection.

- 175 $^\circ\text{C}$ T_J operation
- Center tap module
- Low forward voltage drop
- High frequency operation
- Guard ring for enhanced ruggedness and long term reliability
- Lead-Free

Case Styles



TO-244

Voltage Ratings

Part number	203CNQ100PbF
V_R Max. DC Reverse Voltage (V)	100
V_{RWM} Max. Working Peak Reverse Voltage (V)	

Absolute Maximum Ratings

Parameters	203CNQ	Units	Conditions
$I_{F(AV)}$ Max. Average Forward Current (Per Leg) * See Fig. 5 (Per Device)	100 200	A	50% duty cycle @ $T_C = 142^\circ\text{C}$, rectangular wave form
I_{FSM} Max. Peak One Cycle Non-Repetitive Surge Current (Per Leg) * See Fig. 7	12,800 1,700	A	5 μs Sine or 3 μs Rect. pulse 10ms Sine or 6ms Rect. pulse Following any rated load condition and with rated V_{RRM} applied
E_{AS} Non-Repetitive Avalanche Energy (Per Leg)	15	mJ	$T_J = 25^\circ\text{C}$, $I_{AS} = 13$ Amps, $L = 0.2$ mH
I_{AR} Repetitive Avalanche Current (Per Leg)	1	A	Current decaying linearly to zero in 1 μsec Frequency limited by T_J max. $V_A = 1.5 \times V_R$ typical

Electrical Specifications

Parameters	203CNQ	Units	Conditions
V_{FM} Max. Forward Voltage Drop (Per Leg) * See Fig. 1 (1)	0.86	V	@ 100A $T_J = 25^\circ\text{C}$
	1.03	V	@ 200A
	0.70	V	@ 100A $T_J = 125^\circ\text{C}$
	0.84	V	@ 200A
I_{RM} Max. Reverse Leakage Current (Per Leg) * See Fig. 2 (1)	3	mA	$T_J = 25^\circ\text{C}$
	40	mA	$T_J = 125^\circ\text{C}$ $V_R = \text{rated } V_R$
$V_{F(TO)}$ Threshold Voltage	0.50	V	$T_J = T_J \text{ max.}$
r_t Forward Slope Resistance	1.08	m Ω	
C_T Max. Junction Capacitance (Per Leg)	2,650	pF	$V_R = 5V_{DC}$ (test signal range 100Khz to 1Mhz) 25°C
L_S Typical Series Inductance (Per Leg)	7.0	nH	From top of terminal hole to mounting plane
dv/dt Max. Voltage Rate of Change (Rated V_R)	10000	V/ μs	

(1) Pulse Width < 300 μs , Duty Cycle <2%

Thermal-Mechanical Specifications

Parameters	Min	Typ	Max	Units
T_J Max. Junction Temperature Range	- 55	-	175	$^\circ\text{C}$
T_{Stg} Max. Storage Temperature Range	- 55	-	175	
R_{thJC} Thermal Resistance, Junction to Case	Per Leg	-	0.38	$^\circ\text{C}/\text{W}$
	Per Module	-	0.19	K/W
R_{thCS} Thermal Resistance, Case to Heatsink	-	0.10	-	
Wt Weight	-	68 (2.4)	-	g (oz)
Mounting Torque	35.4 (4)	-	53.1 (6)	lbf*in (Nm)
Mounting Torque Center Hole	30 (3.4)	-	40 (4.6)	
Terminal Torque	30 (3.4)	-	44.2 (5)	
Vertical Pull	-	-	80	lbf.in
2 inch Lever Pull	-	-	35	

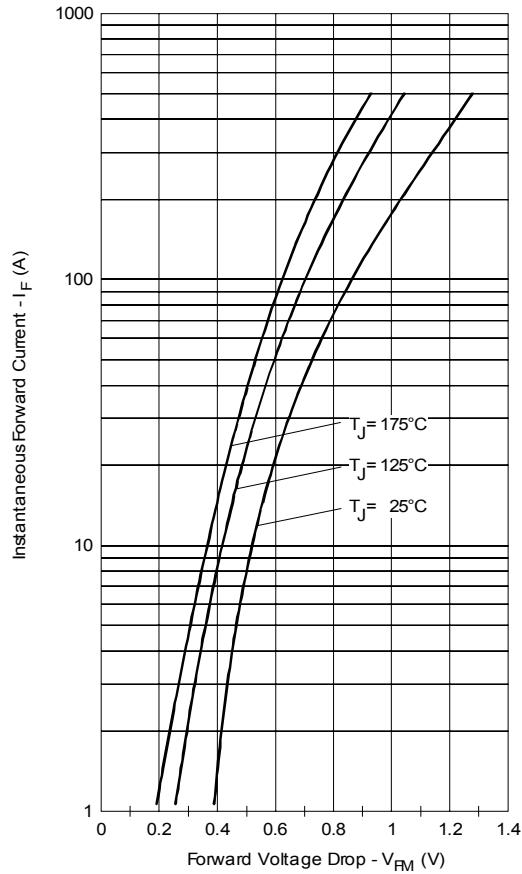

Fig. 1 - Max. Forward Voltage Drop Characteristics (Per Leg)

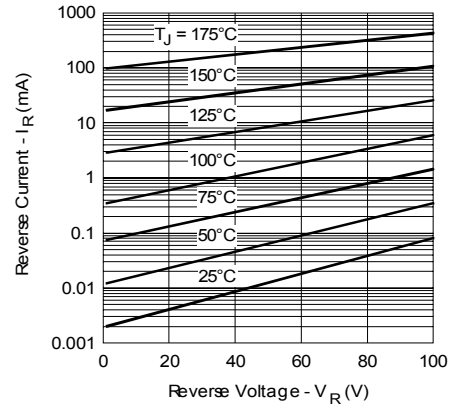

Fig. 2 - Typical Values Of Reverse Current Vs. Reverse Voltage (Per Leg)

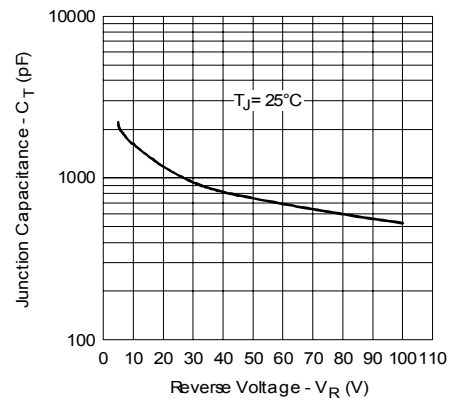

Fig. 3 - Typical Junction Capacitance Vs. Reverse Voltage (Per Leg)

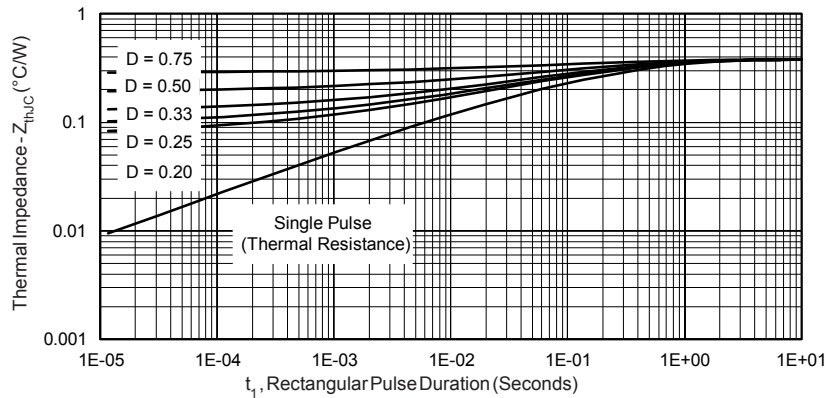

Fig. 4 - Max. Thermal Impedance Z_{thJC} Characteristics (Per Leg)

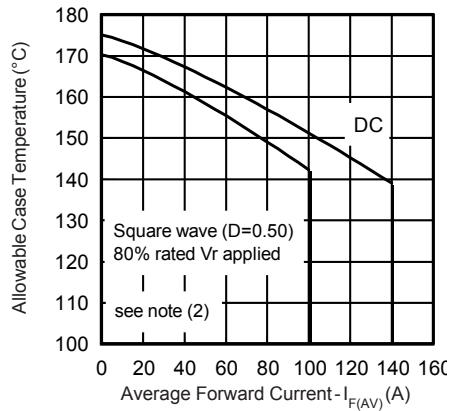

Fig. 5 - Max. Allowable Case Temperature Vs. Average Forward Current (Per Leg)

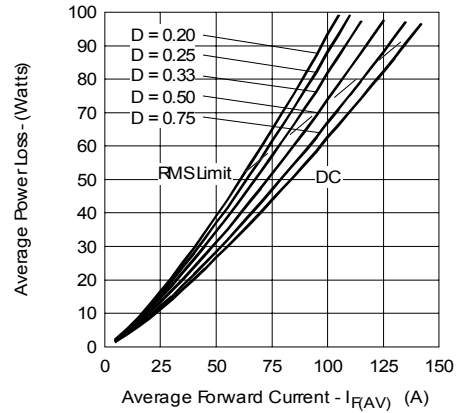

Fig. 6 - Forward Power Loss Characteristics (Per Leg)

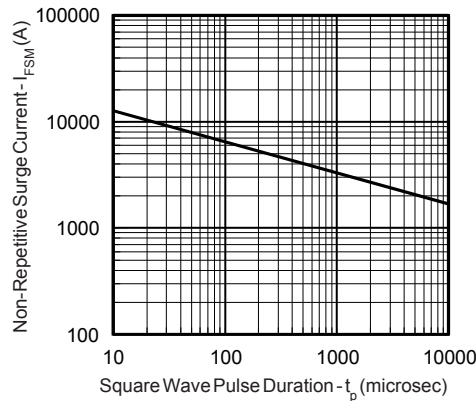

Fig. 7 - Max. Non-Repetitive Surge Current (Per Leg)

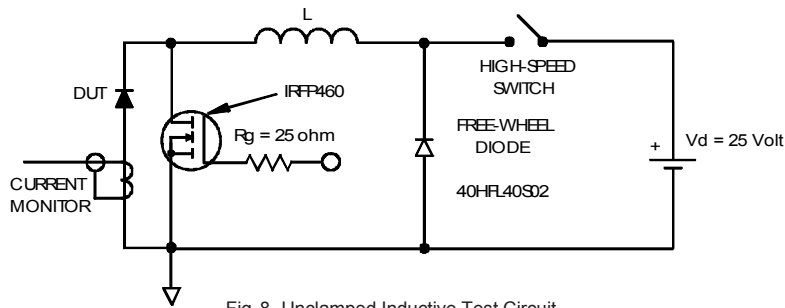

Fig. 8 - Unclamped Inductive Test Circuit

(2) Formula used: $T_c = T_j - (P_d + P_{d_{REV}}) \times R_{thJC}$

P_d = Forward Power Loss = $I_{F(AV)} \times V_{FM} @ (I_{F(AV)} / D)$ (see Fig. 6);

$P_{d_{REV}}$ = Inverse Power Loss = $V_{R1} \times I_R (1 - D)$; $I_R @ V_{R1} = 80\%$ rated V_R

Outline Table

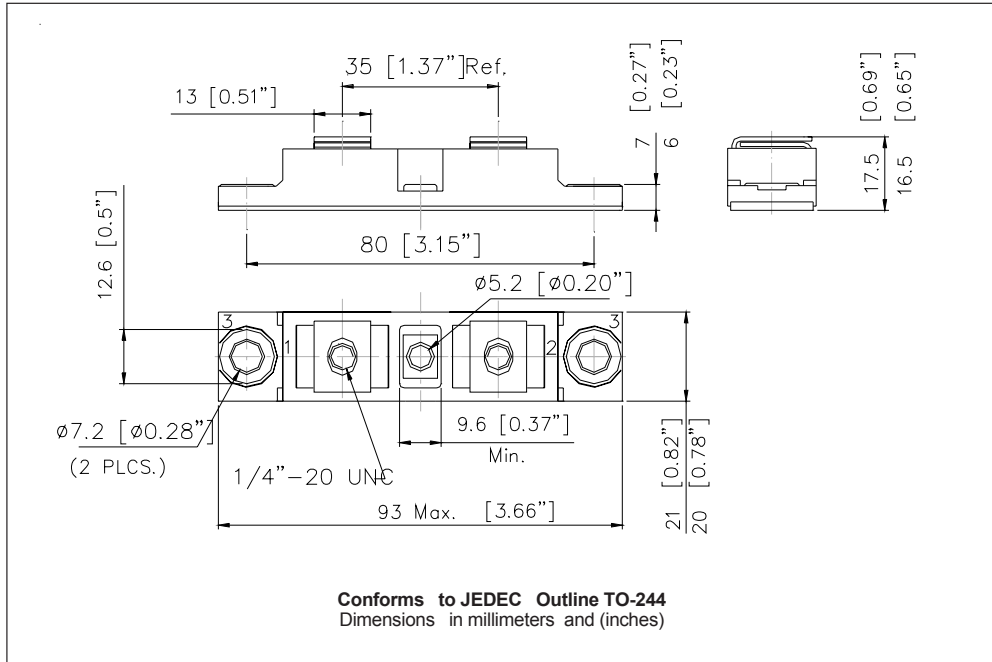

Ordering Information Table

Device Code						
20	3	C	N	Q	100	PbF
①	②	③	④	⑤	⑥	⑦
1	- Average Current Rating (x 10)					
2	- Product Silicon Identification					
3	- C = Circuit Configuration					
4	- N = NOT Isolated					
5	- Q = Schottky Rectifier Diode					
6	- Voltage Rating (100 = 100V)					
7	- Lead-Free					

203CNQ100PbF

Bulletin PD-21103 12/05

International
IOR Rectifier

Data and specifications subject to change without notice.
This product has been designed and qualified for Industrial Level and Lead-Free.
Qualification Standards can be found on IR's Web site.

International
IOR Rectifier

IR WORLD HEADQUARTERS: 233 Kansas St., El Segundo, California 90245, USA Tel: (310) 252-7105
TAC Fax: (310) 252-7309

Visit us at www.irf.com for sales contact information. 12/05