

TOSHIBA CMOS Digital Integrated Circuit Silicon Monolithic

## TC74LCX244F, TC74LCX244FT, TC74LCX244FK

### Low-Voltage Octal Bus Buffer with 5-V Tolerant Inputs and Outputs

The TC74LCX244 is a high-performance CMOS octal bus buffer. Designed for use in 3.3-V systems, it achieves high-speed operation while maintaining the CMOS low power dissipation.

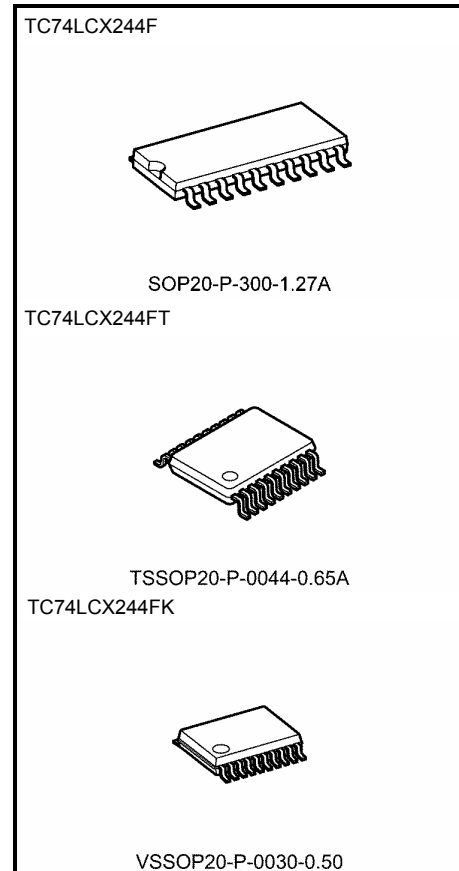
The device is designed for low-voltage (3.3 V)  $V_{CC}$  applications, but it could be used to interface to 5 V supply environment for both inputs and outputs.

The 74LCX244F/FT is a non-inverting 3-state buffer having two active-low output enables. This device is designed to be used with 3-state memory address drivers, etc.

All inputs are equipped with protection circuits against static discharge.

### Features

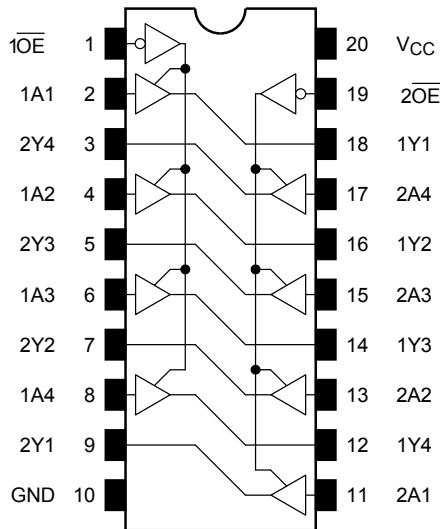
- Low-voltage operation:  $V_{CC} = 2.0$  to  $3.6$  V
- High-speed operation:  $t_{pd} = 6.5$  ns (max) ( $V_{CC} = 3.0$  to  $3.6$  V)
- Output current:  $|I_{OH}|/I_{OL} = 24$  mA (min) ( $V_{CC} = 3.0$  V)
- Latch-up performance:  $-500$  mA
- Available in JEITA SOP, TSSOP and VSSOP (US)
- Power-down protection provided on all inputs and outputs
- Pin and function compatible with the 74 series (74AC/VHC/HC/F/ALS/LS etc.) 244 type



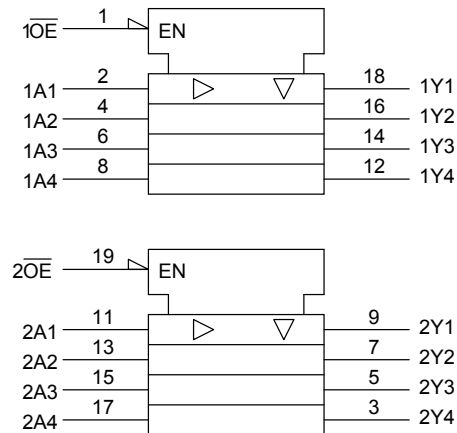
### Weight

SOP20-P-300-1.27A	: 0.22 g (typ.)
TSSOP20-P-0044-0.65A	: 0.08 g (typ.)
VSSOP20-P-0030-0.50	: 0.03 g (typ.)

## Pin Assignment (top view)



## IEC Logic Symbol



## Truth Table

Inputs		Outputs
$\overline{OE}$	$A_n$	
L	L	L
L	H	H
H	X	Z

X: Don't care

Z: High impedance

## Absolute Maximum Ratings (Note 1)

Characteristics	Symbol	Rating	Unit
Power supply voltage	$V_{CC}$	-0.5 to 7.0	V
DC input voltage	$V_{IN}$	-0.5 to 7.0	V
DC output voltage	$V_{OUT}$	-0.5 to 7.0 (Note 2)	V
		-0.5 to $V_{CC} + 0.5$ (Note 3)	
Input diode current	$I_{IK}$	-50	mA
Output diode current	$I_{OK}$	$\pm 50$ (Note 4)	mA
DC output current	$I_{OUT}$	$\pm 50$	mA
Power dissipation	$P_D$	180	mW
DC $V_{CC}$ /ground current	$I_{CC}/I_{GND}$	$\pm 100$	mA
Storage temperature	$T_{stg}$	-65 to 150	$^{\circ}C$

Note 1: Exceeding any of the absolute maximum ratings, even briefly, lead to deterioration in IC performance or even destruction.

Using continuously under heavy loads (e.g. the application of high temperature/current/voltage and the significant change in temperature, etc.) may cause this product to decrease in the reliability significantly even if the operating conditions (i.e. operating temperature/current/voltage, etc.) are within the absolute maximum ratings and the operating ranges.

Please design the appropriate reliability upon reviewing the Toshiba Semiconductor Reliability Handbook ("Handling Precautions"/"Derating Concept and Methods") and individual reliability data (i.e. reliability test report and estimated failure rate, etc).

Note 2: Output in OFF state

Note 3: High or low state.  $I_{OUT}$  absolute maximum rating must be observed.

Note 4:  $V_{OUT} < GND, V_{OUT} > V_{CC}$

## Operating Ranges (Note 1)

Characteristics	Symbol	Rating	Unit
Power supply voltage	$V_{CC}$	2.0 to 3.6	V
		1.5 to 3.6 (Note 2)	
Input voltage	$V_{IN}$	0 to 5.5	V
Output voltage	$V_{OUT}$	0 to 5.5 (Note 3)	V
		0 to $V_{CC}$ (Note 4)	
Output current	$I_{OH}/I_{OL}$	$\pm 24$ (Note 5)	mA
		$\pm 12$ (Note 6)	
Operating temperature	$T_{opr}$	-40 to 85	°C
Input rise and fall time	dt/dv	0 to 10 (Note 7)	ns/V

Note 1: The operating ranges must be maintained to ensure the normal operation of the device.  
Unused inputs must be tied to either  $V_{CC}$  or GND.

Note 2: Data retention only

Note 3: Output in OFF state

Note 4: High or low state

Note 5:  $V_{CC} = 3.0$  to  $3.6$  V

Note 6:  $V_{CC} = 2.7$  to  $3.0$  V

Note 7:  $V_{IN} = 0.8$  to  $2.0$  V,  $V_{CC} = 3.0$  V

## Electrical Characteristics

### DC Characteristics ( $T_a = -40$ to $85^\circ\text{C}$ )

Characteristics		Symbol	Test Condition	$V_{CC}$ (V)	Min	Max	Unit
Input voltage	H-level	$V_{IH}$	—	2.7 to 3.6	2.0	—	V
	L-level	$V_{IL}$	—	2.7 to 3.6	—	0.8	
Output voltage	H-level	$V_{OH}$	$V_{IN} = V_{IH}$ or $V_{IL}$	$I_{OH} = -100 \mu\text{A}$	2.7 to 3.6	$V_{CC} - 0.2$	V
				$I_{OH} = -12 \text{ mA}$	2.7	2.2	
				$I_{OH} = -18 \text{ mA}$	3.0	2.4	
				$I_{OH} = -24 \text{ mA}$	3.0	2.2	
	L-level	$V_{OL}$	$V_{IN} = V_{IH}$ or $V_{IL}$	$I_{OL} = 100 \mu\text{A}$	2.7 to 3.6	—	0.2
				$I_{OL} = 12 \text{ mA}$	2.7	—	0.4
				$I_{OL} = 16 \text{ mA}$	3.0	—	0.4
				$I_{OL} = 24 \text{ mA}$	3.0	—	0.55
Input leakage current	$I_{IN}$	$V_{IN} = 0$ to $5.5$ V	2.7 to 3.6	—	$\pm 5.0$	$\mu\text{A}$	
3-state output off-state current	$I_{OZ}$	$V_{IN} = V_{IH}$ or $V_{IL}$ $V_{OUT} = 0$ to $5.5$ V	2.7 to 3.6	—	$\pm 5.0$	$\mu\text{A}$	
Power off leakage current	$I_{OFF}$	$V_{IN}/V_{OUT} = 5.5$ V	0	—	10.0	$\mu\text{A}$	
Quiescent supply current	$I_{CC}$	$V_{IN} = V_{CC}$ or GND	2.7 to 3.6	—	10.0	$\mu\text{A}$	
		$V_{IN}/V_{OUT} = 3.6$ to $5.5$ V	2.7 to 3.6	—	$\pm 10.0$		
Increase in $I_{CC}$ per input	$\Delta I_{CC}$	$V_{IH} = V_{CC} - 0.6$	2.7 to 3.6	—	500		

### AC Characteristics (Ta = -40 to 85°C)

Characteristics	Symbol	Test Condition	V <sub>CC</sub> (V)	Min	Max	Unit
Propagation delay time	t <sub>pLH</sub>	Figure 1, Figure 2	2.7	—	7.5	ns
	t <sub>pHL</sub>		3.3 ± 0.3	1.5	6.5	
Output enable time	t <sub>pZL</sub>	Figure 1, Figure 3	2.7	—	9.0	ns
	t <sub>pZH</sub>		3.3 ± 0.3	1.5	8.0	
Output disable time	t <sub>pLZ</sub>	Figure 1, Figure 3	2.7	—	8.0	ns
	t <sub>pHZ</sub>		3.3 ± 0.3	1.5	7.0	
Output to output skew	t <sub>osLH</sub>	(Note)	2.7	—	—	ns
	t <sub>osHL</sub>		3.3 ± 0.3	—	1.0	

Note: Parameter guaranteed by design.  
 (t<sub>osLH</sub> = |t<sub>pLHm</sub> - t<sub>pLHn</sub>|, t<sub>osHL</sub> = |t<sub>pHLm</sub> - t<sub>pHLn</sub>|)

### Dynamic Switching Characteristics (Ta = 25°C, input: t<sub>r</sub> = t<sub>f</sub> = 2.5 ns, C<sub>L</sub> = 50 pF, R<sub>L</sub> = 500 Ω)

Characteristics	Symbol	Test Condition	V <sub>CC</sub> (V)	Typ.	Unit
Quiet output maximum dynamic V <sub>OL</sub>	V <sub>OLP</sub>	V <sub>IH</sub> = 3.3 V, V <sub>IL</sub> = 0 V	3.3	0.8	V
Quiet output minimum dynamic V <sub>OL</sub>	V <sub>OLV</sub>	V <sub>IH</sub> = 3.3 V, V <sub>IL</sub> = 0 V	3.3	0.8	V

### Capacitive Characteristics (Ta = 25°C)

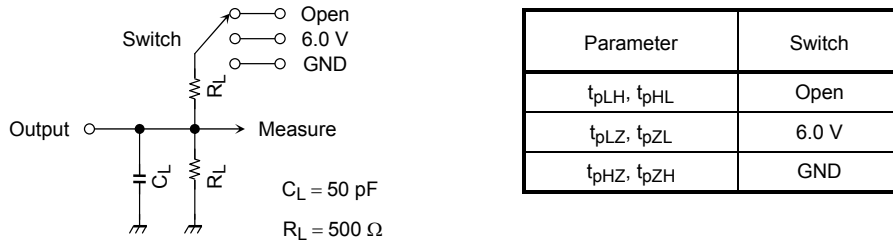
Characteristics	Symbol	Test Condition	V <sub>CC</sub> (V)	Typ.	Unit
Input capacitance	C <sub>IN</sub>	—	3.3	7	pF
Output capacitance	C <sub>OUT</sub>	—	3.3	8	pF
Power dissipation capacitance	C <sub>PD</sub>	f <sub>IN</sub> = 10 MHz (Note)	3.3	25	pF

Note: C<sub>PD</sub> is defined as the value of the internal equivalent capacitance which is calculated from the operating current consumption.

Average operating current can be obtained by the equation:

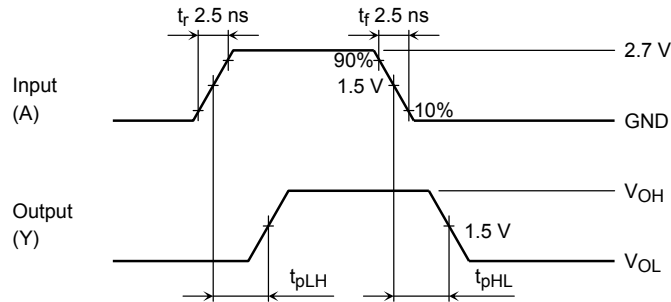
$$I_{CC(opr)} = C_{PD} \cdot V_{CC} \cdot f_{IN} + I_{CC}/8 \text{ (per bit)}$$

**AC Test Circuit**

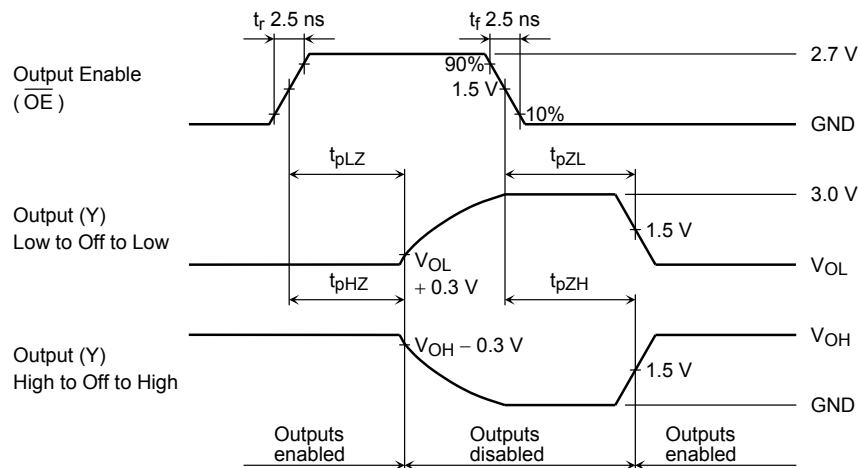


**Figure 1**

**AC Waveform**



**Figure 2  $t_{pLH}, t_{pHL}$**

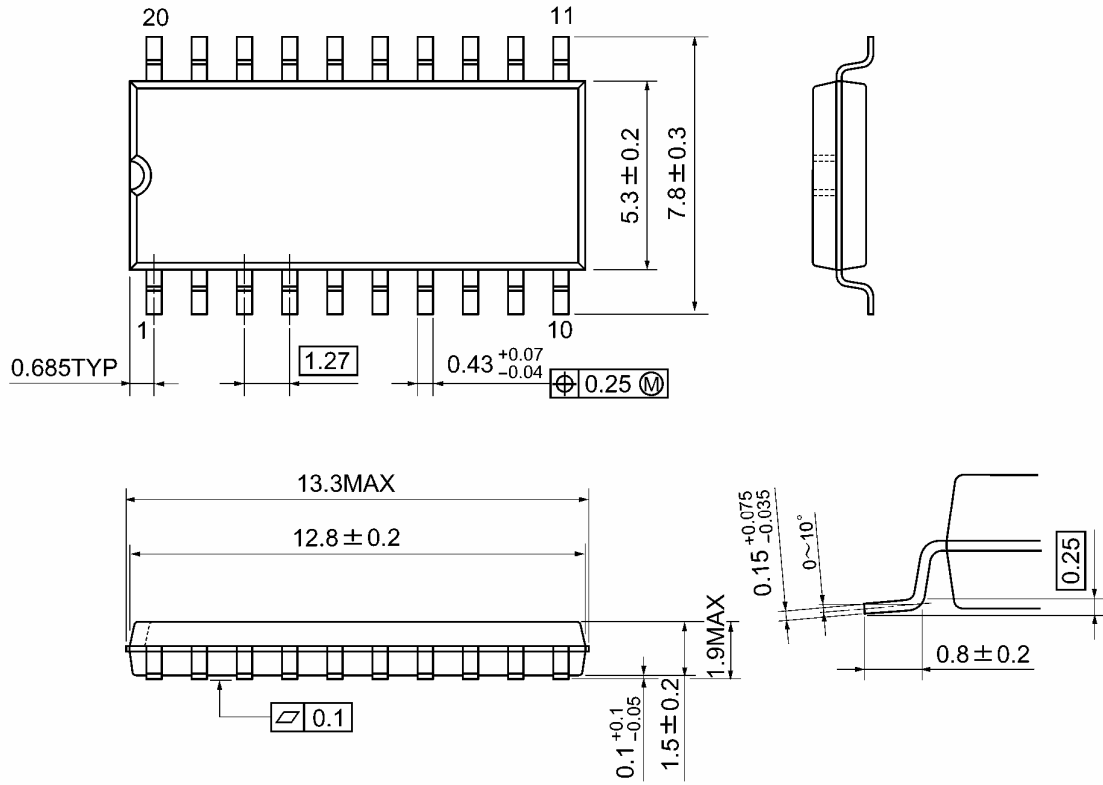


**Figure 3  $t_{pLZ}, t_{pHZ}, t_{pZL}, t_{pZH}$**

## Package Dimensions

SOP20-P-300-1.27A

Unit: mm

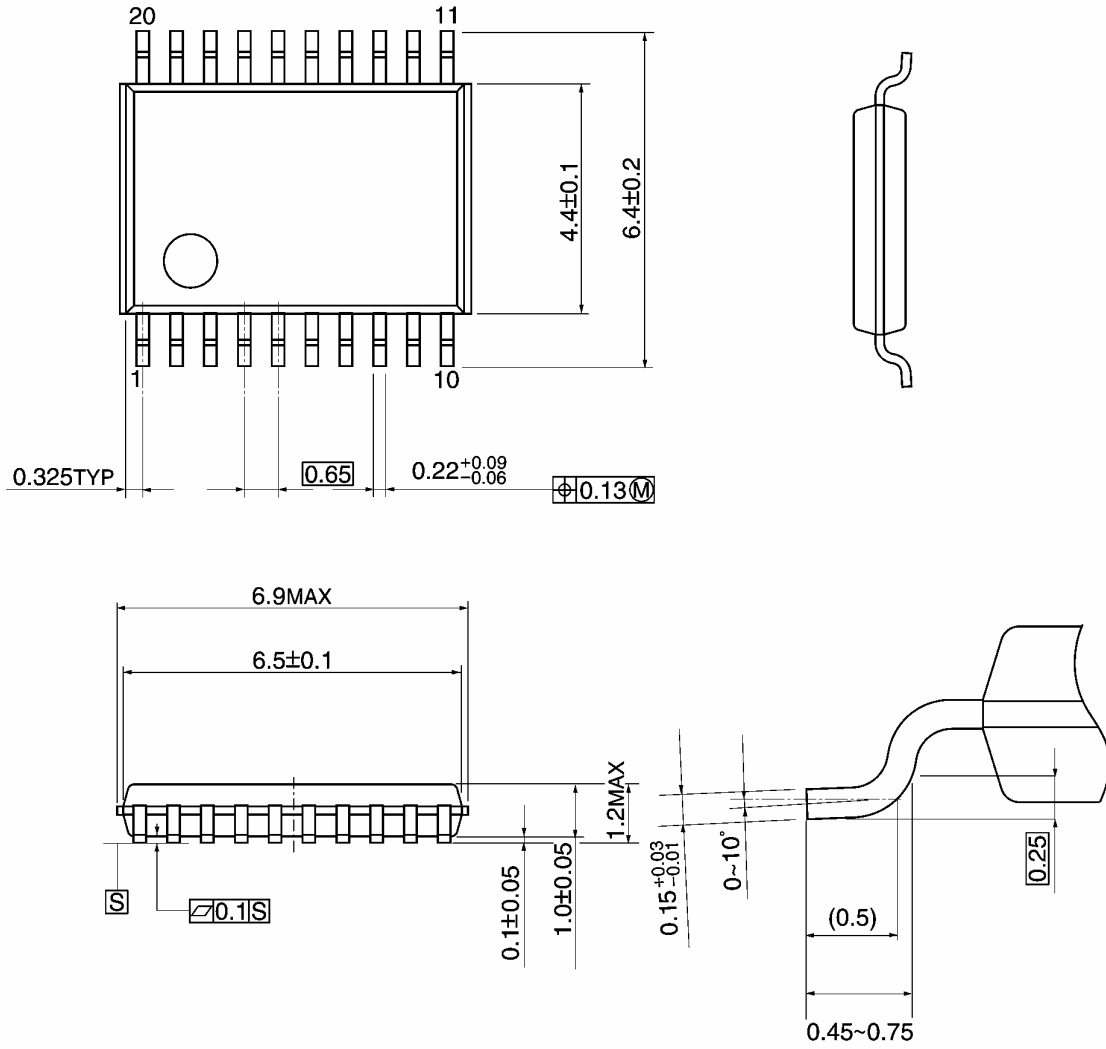


Weight: 0.22 g (typ.)

## Package Dimensions

TSSOP20-P-0044-0.65A

Unit: mm

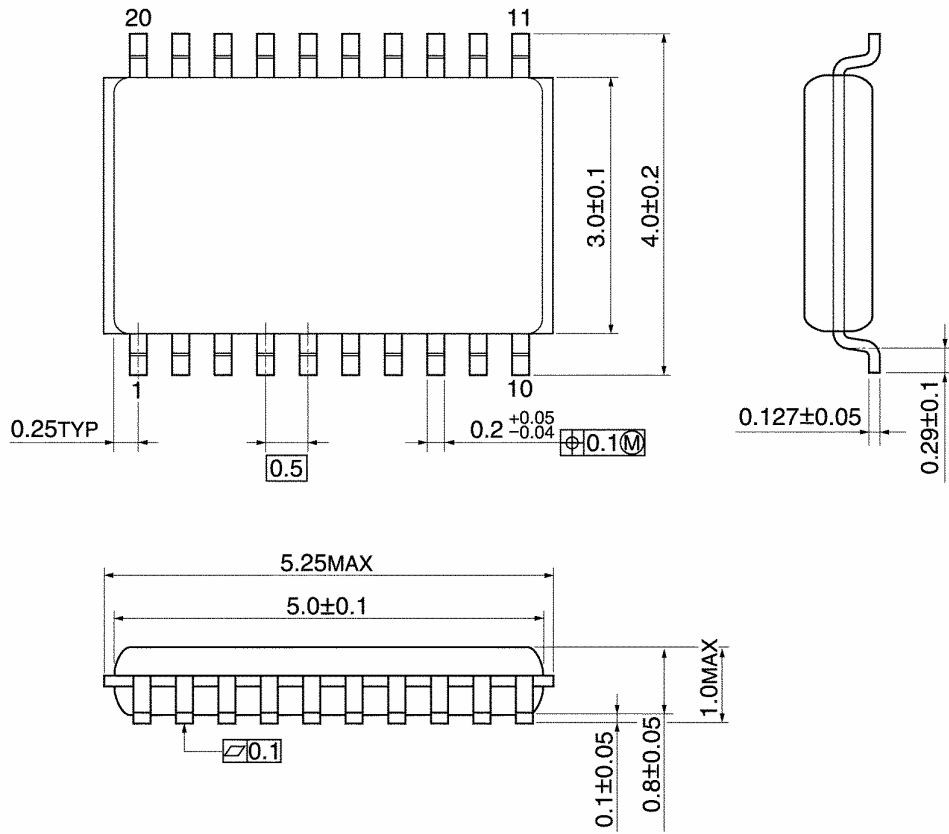


Weight: 0.08 g (typ.)

## Package Dimensions

VSSOP20-P-0030-0.50

Unit: mm



Weight: 0.03 g (typ.)



**RESTRICTIONS ON PRODUCT USE**

20070701-EN GENERAL

- The information contained herein is subject to change without notice.
- TOSHIBA is continually working to improve the quality and reliability of its products. Nevertheless, semiconductor devices in general can malfunction or fail due to their inherent electrical sensitivity and vulnerability to physical stress. It is the responsibility of the buyer, when utilizing TOSHIBA products, to comply with the standards of safety in making a safe design for the entire system, and to avoid situations in which a malfunction or failure of such TOSHIBA products could cause loss of human life, bodily injury or damage to property.  
In developing your designs, please ensure that TOSHIBA products are used within specified operating ranges as set forth in the most recent TOSHIBA products specifications. Also, please keep in mind the precautions and conditions set forth in the "Handling Guide for Semiconductor Devices," or "TOSHIBA Semiconductor Reliability Handbook" etc.
- The TOSHIBA products listed in this document are intended for usage in general electronics applications (computer, personal equipment, office equipment, measuring equipment, industrial robotics, domestic appliances, etc.). These TOSHIBA products are neither intended nor warranted for usage in equipment that requires extraordinarily high quality and/or reliability or a malfunction or failure of which may cause loss of human life or bodily injury ("Unintended Usage"). Unintended Usage include atomic energy control instruments, airplane or spaceship instruments, transportation instruments, traffic signal instruments, combustion control instruments, medical instruments, all types of safety devices, etc.. Unintended Usage of TOSHIBA products listed in this document shall be made at the customer's own risk.
- The products described in this document shall not be used or embedded to any downstream products of which manufacture, use and/or sale are prohibited under any applicable laws and regulations.
- The information contained herein is presented only as a guide for the applications of our products. No responsibility is assumed by TOSHIBA for any infringements of patents or other rights of the third parties which may result from its use. No license is granted by implication or otherwise under any patents or other rights of TOSHIBA or the third parties.
- Please contact your sales representative for product-by-product details in this document regarding RoHS compatibility. Please use these products in this document in compliance with all applicable laws and regulations that regulate the inclusion or use of controlled substances. Toshiba assumes no liability for damage or losses occurring as a result of noncompliance with applicable laws and regulations.