



## TruSurround™ 3D AUDIO PROCESSOR

### ■ GENERAL DESCRIPTION

The **NJM2180** is a TruSurround™<sup>\*1)</sup> 3D audio processor. It regenerates full surround sound field from two speakers by the TruSurround Virtualizer when either 5.1 channels by Dolby Digital<sup>®2)</sup> or 4 channels by Dolby Pro Logic<sup>®2)</sup> signal is input.

The **NJM2180** also performs the SRS 3D-STEREO. In this mode, **NJM2180** regenerates a 3D sound field from normal L/R input.

In addition, the **NJM2180** includes 2-type BYPASS mode THROUGH and MIX DOWN. In THROUGH mode, the **NJM2180** output 5.1 channels (max.) without any processing and in MIX DOWN mode, the **NJM2180** output normal 2 channels stereo signal from 4 or 5.1 channels input

The **NJM2180** is suitable for TV, mini component, CD radio cassette, multimedia speaker systems and others.

### ■ PACKAGE OUTLINE

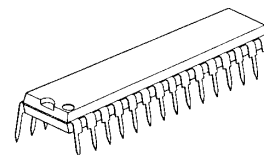

**NJM2180L**

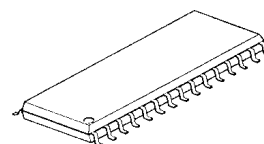

**NJM2180M**

For use in Virtual Dolby Surround(VDS) and/or Virtual Dolby Digital(VDD) products, please contact Dolby Laboratories for licensing information.

### ■ FEATURES

- Operating Voltage (4.7 to 13V)
- Maximum Input Voltage(2.1Vrms typ. at TRU\_4 mode,  $V^+ \geq 11V$ )
- Low Output Noise (35 $\mu$ Vrms typ. at TRU\_4 mode)
- SRS 3D-STEREO FUNCTION
- BYPASS FUNCTION (THROUGH/MIX DOWN)
- Bipolar Technology
- Package Outline SDIP30, SDMP30

\*1)

The TruSurround technology right incorporated in the NJM2180 are owned by SRS Labs, a U.S. Corporation and licensed to New Japan Radio Co., Ltd. TruSurround is protected under U.S. and foreign patents issued and/or pending. TruSurround and the , are trademarks of SRS Labs, Inc. in the United States and selected foreign countries. Neither the purchase of the NJM2180, nor the corresponding sale of audio enhancement equipment conveys the right to sell commercialized recordings made with any TruSurround technology.

SRS Labs requires that all users of the NJM2180 must enter into a license agreement directly with SRS Labs if the royalty is not included in the purchase price. SRS Labs also requires any users to comply with all rules and regulations as outlined in the TruSurround Trademark Usage Manual.

For further information, please contact:  
 SRS Labs, Inc.  
 2909 Daimler Street. Santa Ana, CA 92705 USA  
 Tel:949-442-1070 Fax:949-852-1099 <http://www.srslabs.com>

\*2) Dolby and the double-D symbol are trademarks of Dolby Laboratories Licensing Corporation. Licensing and application information may be obtained from Dolby Lab.

# NJM2180

## ■PIN FUNCTION

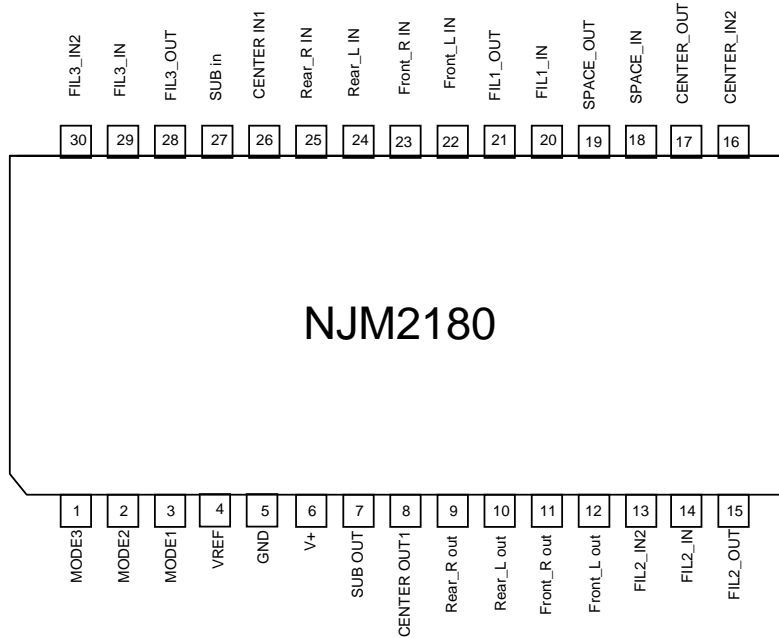

No.	SYMBOL	FUNCTION	No.	SYMBOL	FUNCTION
1	MODE3	Mode Switch	16	CENTER_IN2	CENTER gain adjustment
2	MODE2	Mode Switch	17	CENTER_OUT2	CENTER gain adjustment
3	MODE1	Mode Switch	18	SPACE_IN	SPACE gain adjustment
4	VREF	V+/2	19	SPACE_OUT	SPACE gain adjustment
5	GND	Ground	20	FIL1_IN	Perspective Network_1 input
6	V+	Supply Voltage 4.5 to 13V	21	FIL1_OUT	Perspective Network_1 output
7	SUB OUT	SUB output	22	Front_L in	Front Lch input
8	CENTER OUT1	CENTER output	23	Front_R in	Front Rch input
9	Rear_R OUT	Rear Rch output	24	Rear_L in	Rear Lch input
10	Rear_L OUT	Rear Lch output	25	Rear_R in	Rear Rch input
11	Front_R OUT	Front Rch output	26	CENTER in1	CENTER input
12	Front_L OUT	Front Lch output	27	SUB in	SUB input
13	FIL2_IN2	Perspective Network_2 input	28	FIL3_OUT	Perspective Network_3 output
14	FIL2_IN	Perspective Network_2 input	29	FIL3_IN	Perspective Network_3 input
15	FIL2_OUT	Perspective Network_2 output	30	FIL3_IN2	Perspective Network_3 input

■ **ABSOLUTE MAXIMUM RATING (Ta=25°C)**

PARAMETER	SYMBOL	RATING	UNIT
Supply Voltage	V <sup>+</sup>	15	V
Power Dissipation	P <sub>D</sub>	700	mW
Operating Temperature Range	T <sub>opr</sub>	-20 to +75	°C
Storage Temperature Range	T <sub>stg</sub>	-40 to +125	°C

■ **ELECTRICAL CHARACTERISTICS(V<sup>+</sup>=12V,Ta=25°C, 0dBu=775mVrms)**

PARAMETER	SYMBOL	TEST CONDITION		MIN.	TYP.	MAX.	UNIT
Operating Voltage	V <sup>+</sup>			4.7	12.0	13.0	V
Supply Current	I <sub>cc</sub>	No Signal	BYPASS1,2 MODE	10.0	20.0	30.0	mA
		No Signal	TRU_5.1 MODE	10.0	20.0	30.0	
Reference Voltage	V <sub>REF</sub>	V <sup>+</sup> /2		5.5	6.0	6.5	V
Maximum Input Voltage	V <sub>INMAX</sub>	V <sub>IN</sub> =front L,Rch f=1kHz V <sub>OUT</sub> =L,Rch at THD=3%	BYPASS1 MODE	11.5 (2.9)	13.5 (3.7)	15.5 (4.6)	dBu (Vrms)
		V <sub>IN</sub> =front L,Rch f=1kHz V <sub>OUT</sub> =L,Rch at THD=3%	BYPASS2 MODE	11.5 (2.9)	13.5 (3.7)	15.5 (4.6)	
		V <sub>IN</sub> =front L,Rch f=125Hz V <sub>OUT</sub> =L,Rch at THD=3%	3D-STEREO MODE	9.3 (2.3)	11.3 (2.9)	13.3 (3.6)	
		V <sub>IN</sub> =front L,Rch f=125Hz V <sub>OUT</sub> =L,Rch at THD=3%	TRU_5.1 MODE	9.3 (2.3)	11.3 (2.9)	13.3 (3.6)	
		V <sub>IN</sub> =Rear L,Rch f=125Hz V <sub>OUT</sub> =L,Rch at THD=3%	TRU_5.1 MODE	9.0 (2.2)	11.0 (2.8)	13.0 (3.5)	
		V <sub>IN</sub> =Center, Sub f=1kHz V <sub>OUT</sub> =Lch at THD=3%	TRU_5.1 MODE	11.5 (2.9)	13.5 (3.7)	15.5 (4.6)	
		V <sub>IN</sub> =Rear Lch f=125Hz V <sub>OUT</sub> =L,Rch at THD=3%	TRU_4 MODE	6.5 (1.6)	8.5 (2.1)	10.5 (2.6)	
Output Noise	V <sub>NOISE</sub>	CCIR-ARM V <sub>IN</sub> =GND V <sub>OUT</sub> =L,Rch	BYPASS1 MODE	-	-95.0 (17)	-84.0 (63)	dBV (μVrms)
		CCIR-ARM V <sub>IN</sub> =GND V <sub>OUT</sub> =L,Rch	BYPASS2 MODE	-	-98.0 (13)	-84.0 (63)	
		CCIR-ARM V <sub>IN</sub> =GND V <sub>OUT</sub> =L,Rch	3D-STEREO MODE	-	-89.0 (35)	-84.0 (63)	
		CCIR-ARM V <sub>IN</sub> =GND V <sub>OUT</sub> =L,Rch	TRU_5.1 MODE	-	-89.0 (35)	-84.0 (63)	
		CCIR-ARM V <sub>IN</sub> =GND V <sub>OUT</sub> =L,Rch	TRU_4 MODE	-	-89.0 (35)	-84.0 (63)	

# NJM2180

## ■ ELECTRICAL CHARACTERISTICS ( $V^+=12V, T_a=25^\circ C, 0dBu=775mVrms$ )

PARAMETER	SYMBOL	TEST CONDITION		MIN.	TYP.	MAX.	UNIT
Total Harmonic Distortion	THD	$V_{IN}=-10dBu$ Front Lch $f=1kHz, V_{OUT}=Lch$	BYPASS1 MODE	0.001	0.1	0.5	%
		$V_{IN}=-10dBu$ Front Lch $f=1kHz, V_{OUT}=Lch$	BYPASS2 MODE	0.001	0.01	0.5	
		$V_{IN}=-10dBu$ Front Lch $f=1kHz, V_{OUT}=L, Rch$	3D-STEREO MODE	0.01	0.1	0.5	
		$V_{IN}=-10dBu$ Front Lch $f=1kHz, V_{OUT}=L, Rch$	TRU_5.1 MODE	0.01	0.1	0.5	
		$V_{IN}=-10dBu$ Rear Lch $f=1kHz, V_{OUT}=L, Rch$	TRU_5.1 MODE	0.01	0.1	0.5	
		$V_{IN}=-10dBu$ Front Lch $f=1kHz, V_{OUT}=L, Rch$	TRU_4 MODE	0.01	0.1	0.5	
		$V_{IN}=-10dBu$ Rear Lch $f=1kHz, V_{OUT}=L, Rch$	TRU_4 MODE	0.01	0.1	0.5	
BYPASS1 Gain	$G_{Bypass1}$	$V_{IN}=0dBu$ Front Lch $f=1kHz, V_{OUT}=L, Rch$	BYPASS1 MODE	-4.9	-2.9	-0.9	dB
BYPASS2 Gain	$G_{Bypass2}$	$V_{IN}=0dBu$ Front Lch $f=1kHz, V_{OUT}=L, Rch$	BYPASS2 MODE	-2.0	0.0	2.0	dB
TRU Front Gain	$G_{TRUF}$	$V_{IN}=0dBu$ Front Lch $f=125Hz, V_{OUT}=Lch$	TRU_5.1 MODE	-0.2	1.8	3.8	dB
TRU Rear Gain	$G_{TRUR}$	$V_{IN}=0dBu$ Rear Lch $f=125Hz, V_{OUT}=Lch$	TRU_5.1 MODE	0.8	2.8	4.8	dB
TRU Rear Gain	$G_{TRUR}$	$V_{IN}=0dBu$ Rear Lch $f=125Hz, V_{OUT}=L, Rch$	TRU_4 MODE	1.5	3.5	5.5	dB
CENTER Gain	$G_{CENTER}$	$V_{IN}=0dBu$ Center ch $f=1kHz, V_{OUT}=L, Rch$	TRU_4 MODE	-4.9	-2.9	-0.9	dB
SUB Gain	$G_{SUB}$	$V_{IN}=0dBu$ Sub ch $f=1kHz, V_{OUT}=L, Rch$	TRU_4 MODE	-2.0	0.0	-2.0	dB
Feed Through Gain	$G_{THROUGH}$	$V_{IN}=0dBu$ Front Lch $f=1kHz, V_{OUT}=Lch$ SPACE VR Min CENTER VR Min	3D-STEREO MODE	-20.2	-18.2	-16.2	dB
L+R Gain	$G_{L+R}$	$V_{IN}=0dBu$ Front Lch $f=1kHz, V_{OUT}=Rch$ SPACE VR Min CENTER VR Max	3D-STEREO MODE	-15.0	-13.0	-11.0	dB
L-R Gain	$G_{L-R}$	$V_{IN}=0dBu$ Front Lch $f=125Hz, V_{OUT}=Rch$ SPACE VR Max CENTER VR Min	3D-STEREO MODE	-2.0	0.0	2.0	dB
MODE Select Control Voltage	$V_{MODE}$	$V_{IN}=High Level$		2.0	-	$V^+$	V
		$V_{IN}=Low Level$		0.0	-	0.7	

■ **MODE SELECT FUNCTION**

MODE	MODE1	MODE2	MODE3	NOTE
BYPASS_1	L	L	L	MIX DOWN MODE (2-Channel Output)
BYPASS_2	L	L	H	INPUT THROUGH MODE (Multi-Channel Output)
TSV_5.1	L	H	L	TruSurround MODE (Dolby Digital Decoded Source) Variable effects by SPACE and CENTER VR
TSV_4	L	H	H	TruSurround MODE (Dolby Pro Logic Decoded Source) Variable effects by SPACE and CENTER VR
3D-STEREO	H	L	-	SRS 3D-STEREO MODE (Normal STEREO Source) Variable effects by SPACE and CENTER VR
TRU_5.1	H	H	L	TruSurround MODE (Dolby Digital Decoded Source) Standard effects
TRU_4	H	H	H	TruSurround MODE (Dolby Pro Logic Decoded Source) Standard effects

# NJM2180

## ■ BLOCK DIAGRAM

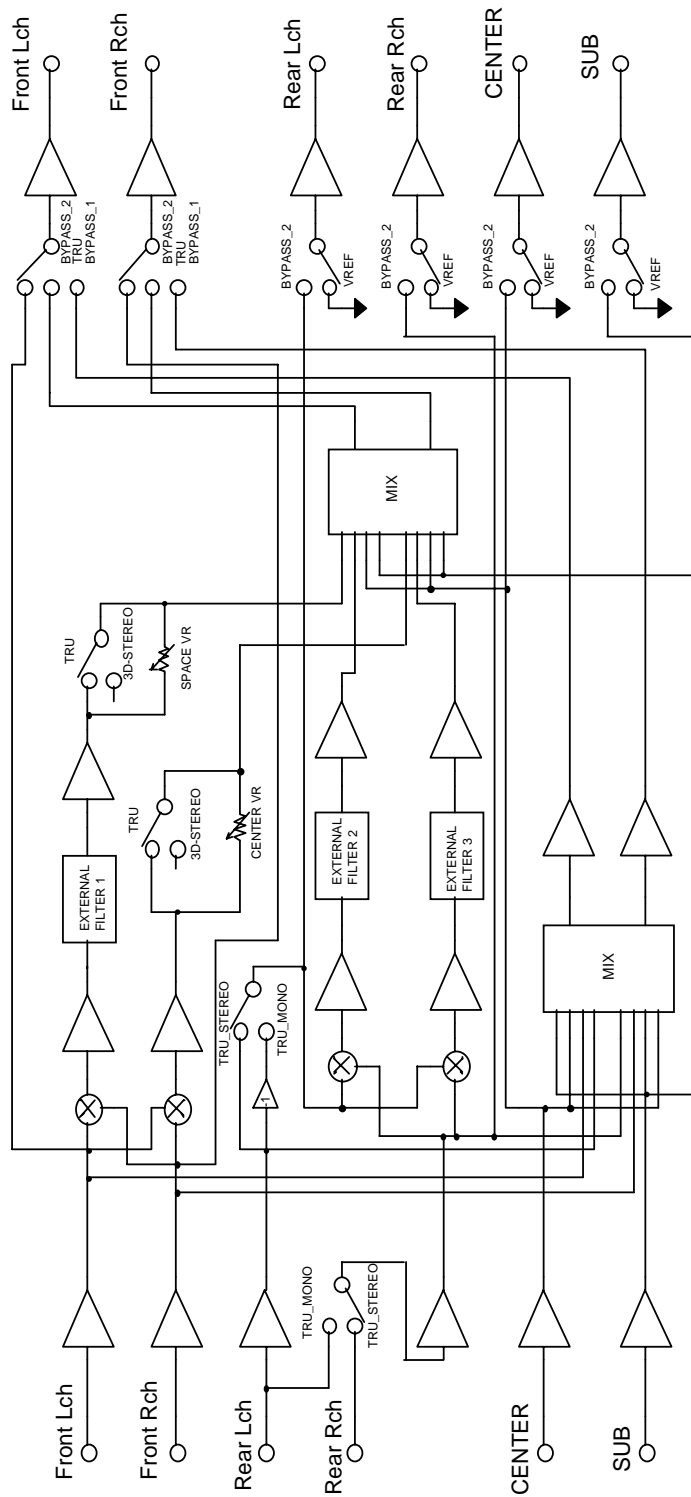

## ■ PIN DESCRIPTION

1,2,3 PIN

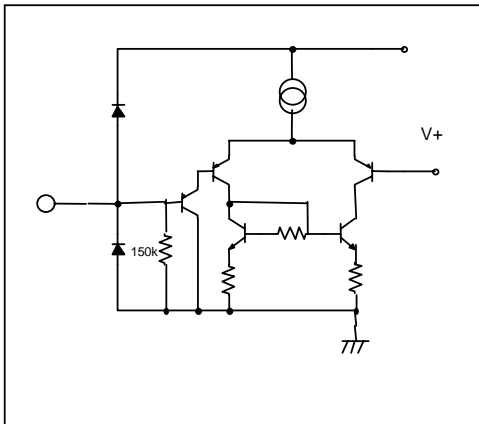

4,7,8,9,10,11,12,15,17,21,28 PIN

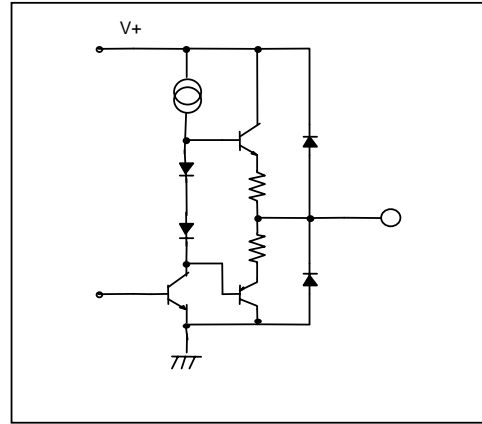

13,19,30 PIN

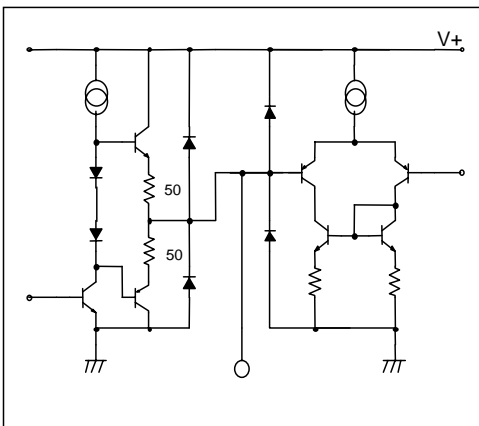

22,23,24,25,26,27 PIN

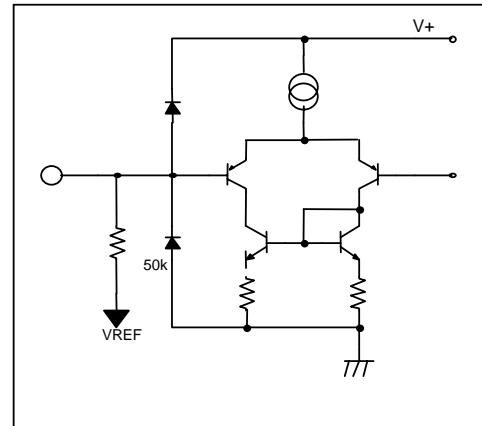

14,20,29 PIN

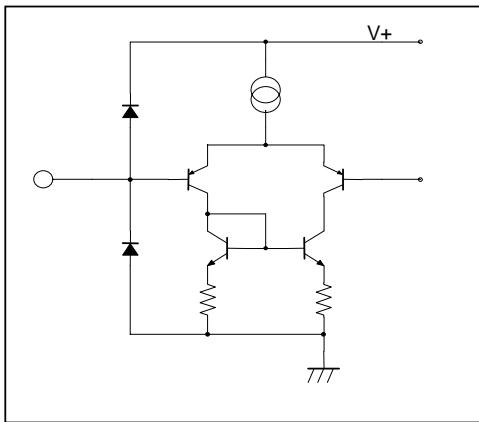

16,18 PIN

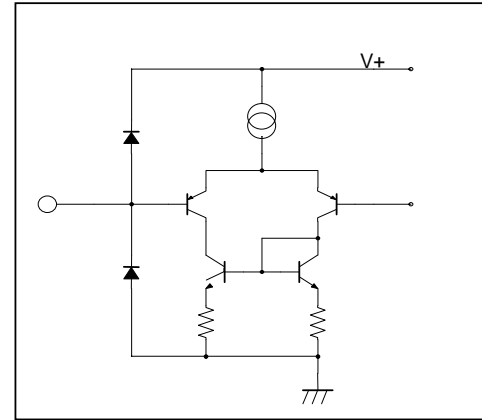

# NJM2180

## APPLICATION CIRCUIT

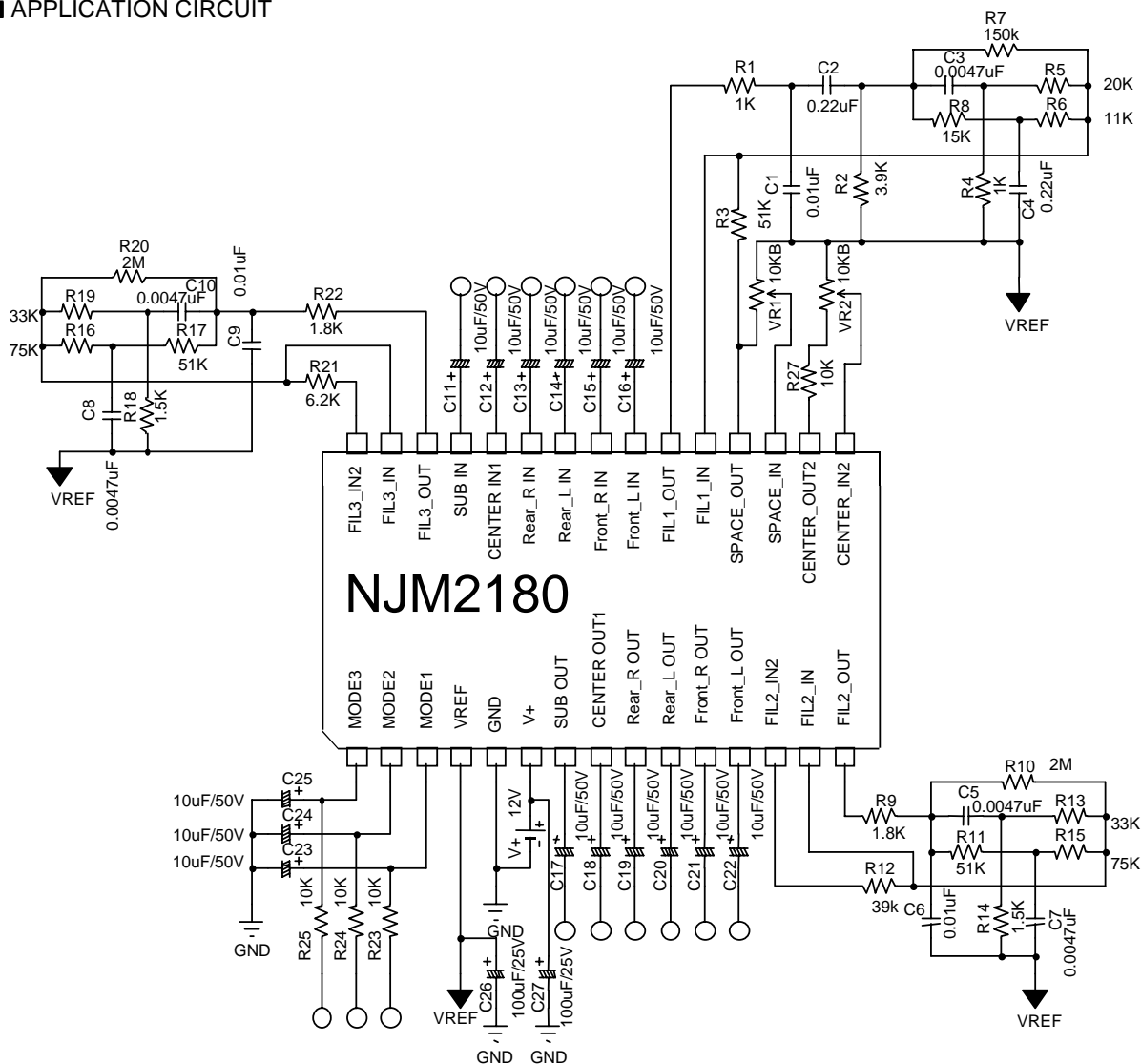

Note: In case of TRU\_4 or TSV\_4 MODE, input the mono signal of surround channel from Dolby Pro Logic decoder into Rear\_L IN terminal or both of Rear\_L IN and Rear\_R IN terminals.

PART No.	VALUE	Tolerance	PART No.	VALUE	Tolerance
C1,C6,C9	0.01 $\mu$ F	$\pm$ 5%	R6	11k	$\pm$ 5%
C2,C4	0.22 $\mu$ F	$\pm$ 5%	R7	150k	
C3,C5,C7,C8,C10	0.0047 $\mu$ F	$\pm$ 5%	R8	15k	$\pm$ 5%
C11,C12,C13,C14,C15,C16,	10 $\mu$ F		R9,R22	1.8k	$\pm$ 5%
C17,C18,C19,C20,C21,C22,	10 $\mu$ F		R10,R20	2M	$\pm$ 5%
C23,C24,C25	10 $\mu$ F		R12	39k	$\pm$ 5%
C26,C27	100 $\mu$ F		R13,R19	33k	$\pm$ 5%
R1,R4	1k	$\pm$ 5%	R14,R18	1.5k	$\pm$ 5%
R2	3.9k	$\pm$ 5%	R15,R16	75k	$\pm$ 5%
R3,R11,R17	51k	$\pm$ 5%	R21	6.2k	$\pm$ 5%
R5	20k	$\pm$ 5%	R23,R24,R25,R27	10k	$\pm$ 5%



## ■ TYPICAL CHARACTERISTICS

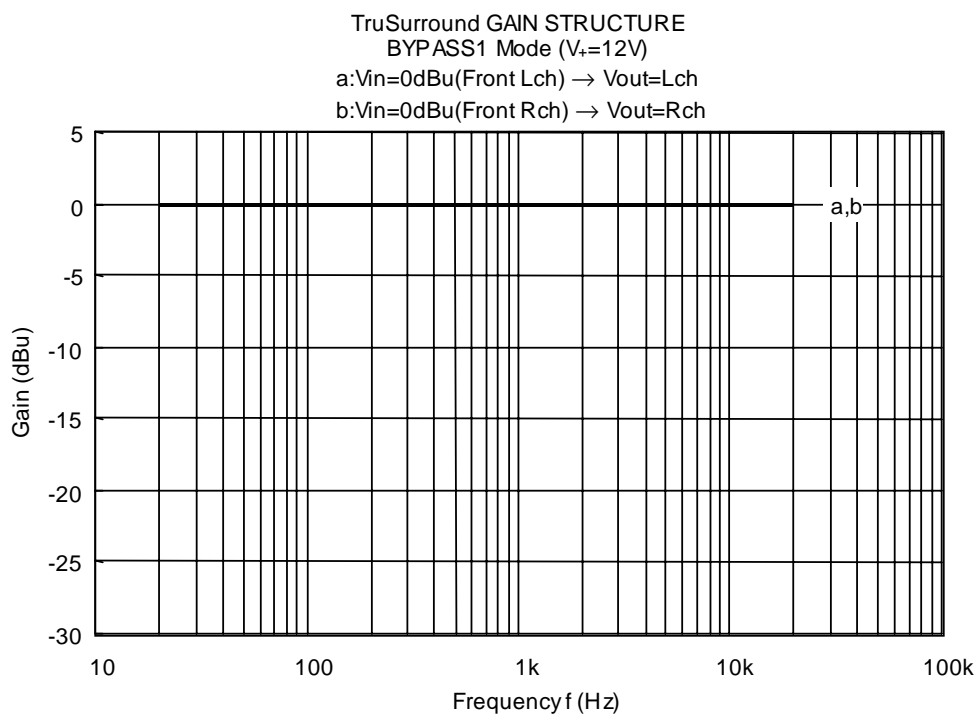
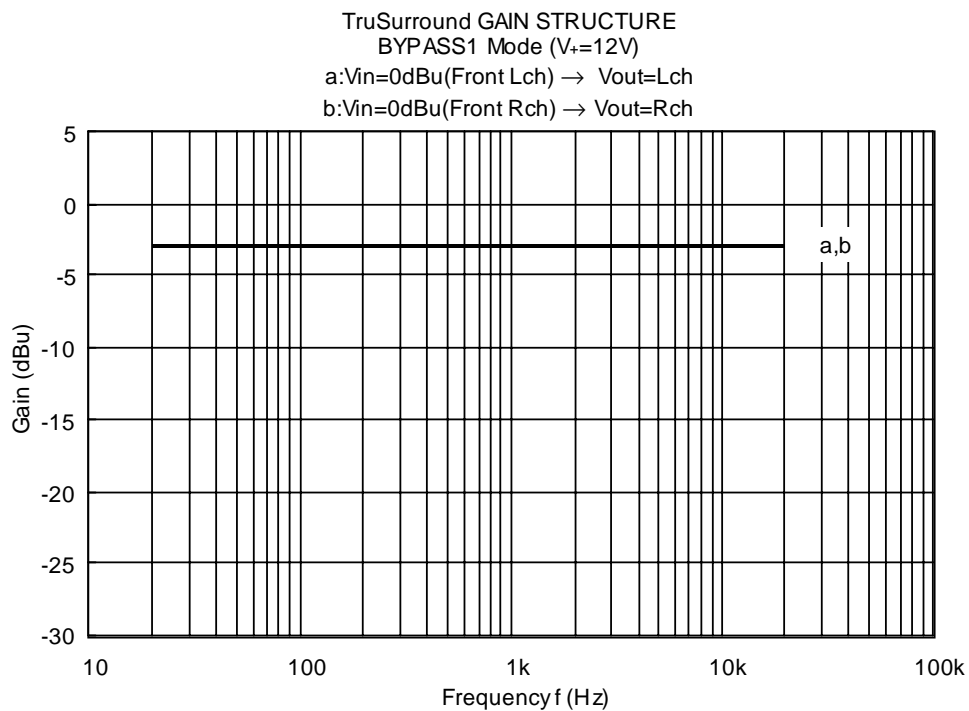

# NJM2180

## ■ TYPICAL CHARACTERISTICS

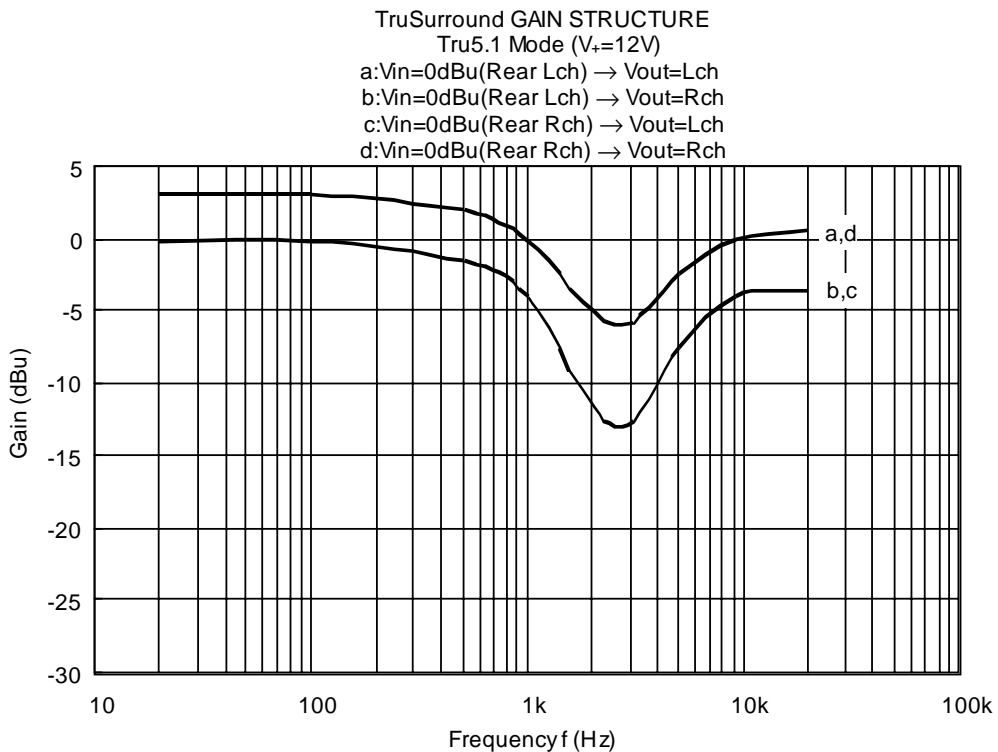
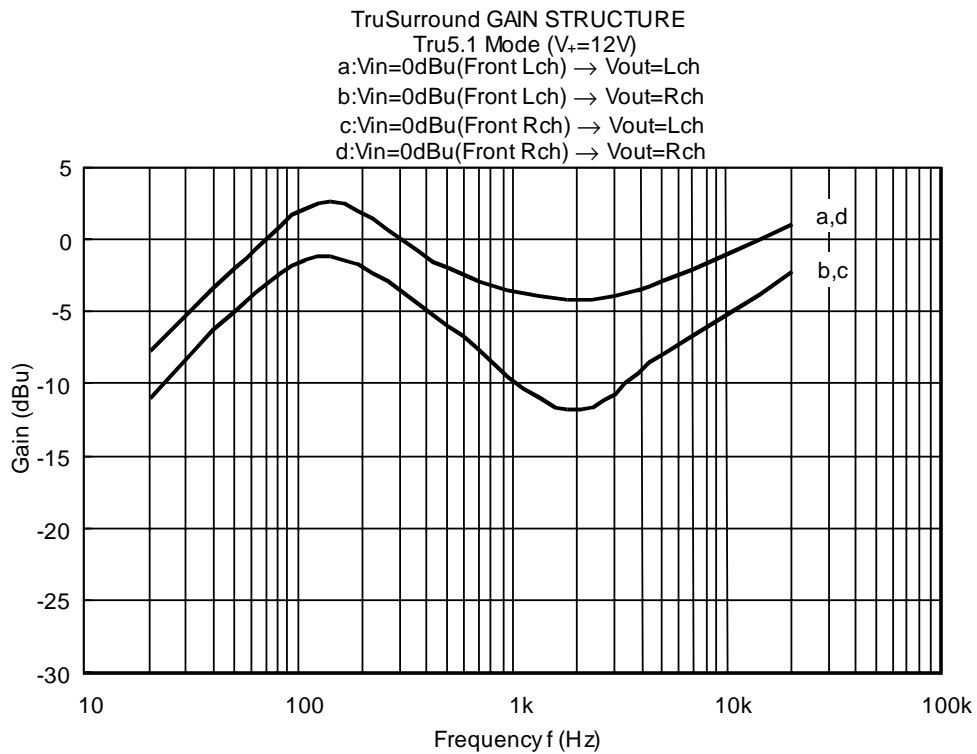

## ■ TYPICAL CHARACTERISTICS

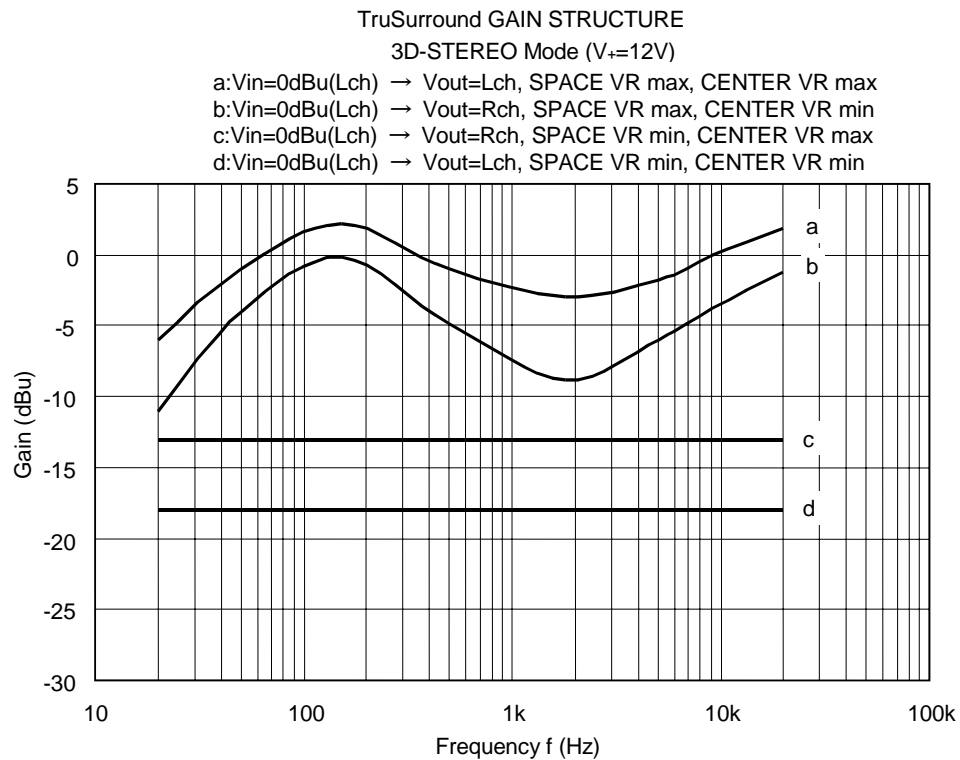
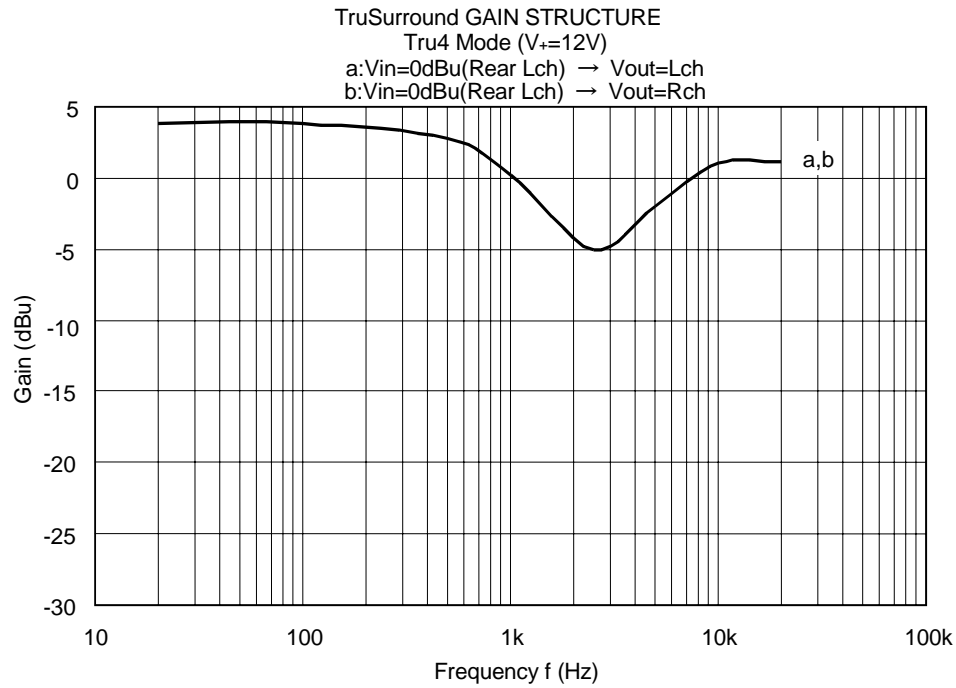

**[CAUTION]**  
The specifications on this databook are only given for information, without any guarantee as regards either mistakes or omissions. The application circuits in this databook are described only to show representative usages of the product and not intended for the guarantee or permission of any right including the industrial rights.