

## 74F164A Serial-In, Parallel-Out Shift Register

### General Description

The 74F164A is a high-speed 8-bit serial-in/parallel-out shift register. Serial data is entered through a 2-input AND gate synchronous with the LOW-to-HIGH transition of the clock. The device features an asynchronous Master Reset which clears the register, setting all outputs LOW independent of the clock. The 74F164A is a faster version of the 74F164.

### Features

- Typical shift frequency of 90 MHz
- Asynchronous Master Reset
- Gated serial data input
- Fully synchronous data transfers
- 74F164A is a faster version of the 74F164

### Ordering Code:

| Order Number | Package Number | Package Description   |
|--------------|----------------|---|
| 74F164ASC    | M14A           | 14-Lead Small Outline Integrated Circuit (SOIC), JEDEC MS-120, 0.150 Narrow |
| 74F164ASJ    | M14D           | 14-Lead Small Outline Package (SOP), EIAJ TYPE II, 5.3mm Wide               |
| 74F164APC    | N14A           | 14-Lead Plastic Dual-In-Line Package (PDIP), JEDEC MS-001, 0.300 Wide       |

Devices also available in Tape and Reel. Specify by appending the suffix letter "X" to the ordering code.

### Logic Symbols

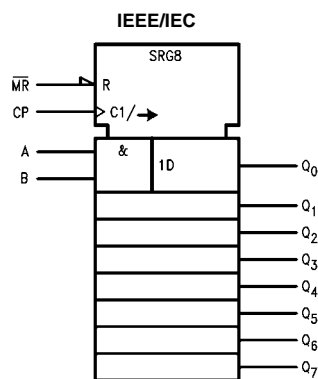
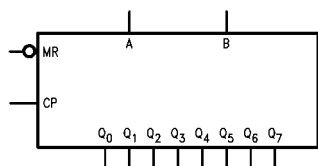

### Connection Diagram

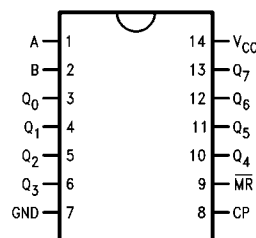

## Unit Loading/Fan Out

| Pin Names       | Description                            | U.L.<br>HIGH/LOW | Input $I_{IH}/I_{IL}$<br>Output $I_{OH}/I_{OL}$ |
|-----------------|--|------------------|---|
| A, B            | Data Inputs                            | 1.0/1.0          | 20 $\mu$ A/-0.6 mA                              |
| CP              | Clock Pulse Input (Active Rising Edge) | 1.0/1.0          | 20 $\mu$ A/-0.6 mA                              |
| $\overline{MR}$ | Master Reset Input (Active LOW)        | 1.0/1.0          | 20 $\mu$ A/-0.6 mA                              |
| $Q_0$ - $Q_7$   | Outputs                                | 50/33.3          | -1 mA/20 mA                                     |

## Functional Description

The 74F164A is an edge-triggered 8-bit shift register with serial data entry and an output from each of the eight stages. Data is entered serially through one of two inputs (A or B); either of these inputs can be used as an active HIGH Enable for data entry through the other input. An unused input must be tied HIGH.

Each LOW-to-HIGH transition on the Clock (CP) input shifts data one place to the right and enters into  $Q_0$  the logical AND of the two data inputs ( $A \cdot B$ ) that existed before the rising clock edge. A LOW level on the Master Reset ( $\overline{MR}$ ) input overrides all other inputs and clears the register asynchronously, forcing all Q outputs LOW.

## Mode Select Table

| Operating Mode | Inputs          |   |   | Outputs |               |
|----------------|-----------------|---|---|---------|---------------|
|                | $\overline{MR}$ | A | B | $Q_0$   | $Q_1$ - $Q_7$ |
| Reset (Clear)  | L               | X | X | L       | L-L           |
| Shift          | H               | l | l | L       | $q_0$ - $q_6$ |
|                | H               | l | h | L       | $q_0$ - $q_6$ |
|                | H               | h | l | L       | $q_0$ - $q_6$ |
|                | H               | h | h | H       | $q_0$ - $q_6$ |

H(h) = HIGH Voltage Levels

L(l) = LOW Voltage Levels

X = Immaterial

$q_n$  = Lower case letters indicate the state of the referenced input or output one setup time prior to the LOW-to-HIGH clock transition.

## Logic Diagram

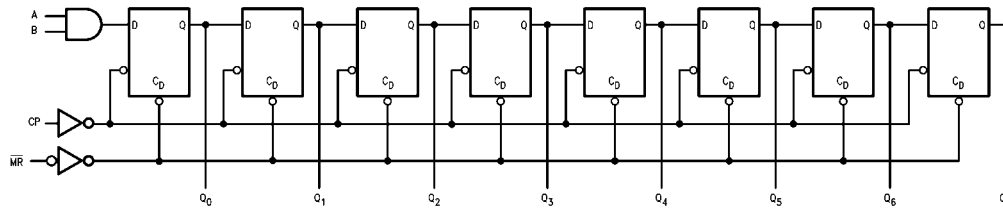

Please note that this diagram is provided only for the understanding of logic operations and should not be used to estimate propagation delays.

**Absolute Maximum Ratings**(Note 1)

|  |                                      |
|--|--------------------------------------|
| Storage Temperature  | -65°C to +150°C                      |
| Ambient Temperature under Bias   | -55°C to +125°C                      |
| Junction Temperature under Bias  | -55°C to +150°C                      |
| V <sub>CC</sub> Pin Potential to Ground Pin                            | -0.5V to +7.0V                       |
| Input Voltage (Note 1)   | -0.5V to +7.0V                       |
| Input Current (Note 1)   | -30 mA to +5.0 mA                    |
| Voltage Applied to Output<br>in HIGH State (with V <sub>CC</sub> = 0V) |                                      |
| Standard Output  | -0.5V to V <sub>CC</sub>             |
| 3-STATE Output   | -0.5V to +5.5V                       |
| Current Applied to Output<br>in LOW State (Max)                        | twice the rated I <sub>OL</sub> (mA) |
| ESD Last Passing Voltage (Min)   | 4000V                                |

**Recommended Operating Conditions**

|                              |                |
|------------------------------|----------------|
| Free Air Ambient Temperature | 0°C to +70°C   |
| Supply Voltage               | +4.5V to +5.5V |

**Note 1:** Absolute maximum ratings are values beyond which the device may be damaged or have its useful life impaired. Functional operation under these conditions is not implied.

**Note 2:** Either voltage limit or current limit is sufficient to protect inputs.

**DC Electrical Characteristics**

| Symbol           | Parameter                         | Min                                       | Typ | Max  | Units | V <sub>CC</sub> | Conditions   |
|------------------|-----------------------------------|---|-----|------|-------|-----------------|--|
| V <sub>IH</sub>  | Input HIGH Voltage                | 2.0                                       |     |      | V     |                 | Recognized as a HIGH Signal                          |
| V <sub>IL</sub>  | Input LOW Voltage                 |   |     | 0.8  | V     |                 | Recognized as a LOW Signal                           |
| V <sub>CD</sub>  | Input Clamp Diode Voltage         |   |     | -1.2 | V     | Min             | I <sub>IN</sub> = -18 mA                             |
| V <sub>OH</sub>  | Output HIGH Voltage               | 10% V <sub>CC</sub><br>5% V <sub>CC</sub> |     |      | V     | Min             | I <sub>OH</sub> = -1 mA<br>I <sub>OH</sub> = -1 mA   |
| V <sub>OL</sub>  | Output LOW Voltage                | 10% V <sub>CC</sub>                       |     | 0.5  | V     | Min             | I <sub>OL</sub> = 20 mA                              |
| I <sub>IH</sub>  | Input HIGH Current                |   |     | 5.0  | μA    | Max             | V <sub>IN</sub> = 2.7V                               |
| I <sub>BV1</sub> | Input HIGH Current Breakdown Test |   |     | 7.0  | μA    | Max             | V <sub>IN</sub> = 7.0V                               |
| I <sub>CEX</sub> | Output HIGH Leakage Current       |   |     | 50   | μA    | Max             | V <sub>OUT</sub> = V <sub>CC</sub>                   |
| V <sub>ID</sub>  | Input Leakage Test                | 4.75                                      |     |      | V     | 0.0             | I <sub>ID</sub> = 1.9 μA<br>All other pins grounded  |
| I <sub>OD</sub>  | Output Leakage Circuit Current    |   |     | 3.75 | μA    | 0.0             | V <sub>IOD</sub> = 150 mV<br>All other pins grounded |
| I <sub>IL</sub>  | Input LOW Current                 |   |     | -0.6 | mA    | Max             | V <sub>IN</sub> = 0.5V                               |
| I <sub>OS</sub>  | Output Short-Circuit Current      | -60                                       |     | -150 | mA    | Max             | V <sub>OUT</sub> = 0V                                |
| I <sub>CC</sub>  | Power Supply Current              |   | 35  | 55   | mA    | Max             | CP = HIGH<br>MR = GND, A, B = GND                    |

| AC Electrical Characteristics |   |   |     |  |  |   |   |       |       |
|-------------------------------|---|---|-----|--|--|---|---|-------|-------|
| Symbol                        | Parameter                                 | T <sub>A</sub> = +25°C<br>V <sub>CC</sub> = +5.0V<br>C <sub>L</sub> = 50 pF |     |  | T <sub>A</sub> = -55°C to +125°C<br>V <sub>CC</sub> = 5.0V<br>C <sub>L</sub> = 50 pF |   | T <sub>A</sub> = 0°C to +70°C<br>V <sub>CC</sub> = 5.0V<br>C <sub>L</sub> = 50 pF |       | Units |
|                               |   | Min   | Typ | Max  | Min  | Max   | Min   | Max   |       |
| f <sub>MAX</sub>              | Maximum Clock Frequency                   | 80  | 120 |  | 60   |   | 80  |       | MHz   |
| t <sub>PLH</sub>              | Propagation Delay<br>CP to Q <sub>n</sub> | 3.0   | 4.8 | 7.5  | 2.5  | 9.0   | 3.0   | 7.5   | ns    |
| t <sub>PHL</sub>              | Propagation Delay<br>MR to Q <sub>n</sub> | 3.5   | 5.0 | 8.0  | 3.0  | 8.5   | 3.5   | 8.0   |       |
| t <sub>PHL</sub>              | Propagation Delay<br>MR to Q <sub>n</sub> | 5.0   | 7.0 | 10.0   | 4.0  | 12.5  | 5.0   | 10.5  | ns    |
| AC Operating Requirements     |   |   |     |  |  |   |   |       |       |
| Symbol                        | Parameter                                 | T <sub>A</sub> = +25°C<br>V <sub>CC</sub> = +5.0V                           |     | T <sub>A</sub> = -55°C to +125°C<br>V <sub>CC</sub> = 5.0V |  | T <sub>A</sub> = 0°C to +70°C<br>V <sub>CC</sub> = 5.0V |   | Units |       |
|                               |   | Min   | Max | Min  | Max  | Min   | Max   |       |       |
| t <sub>S(H)</sub>             | Setup Time, HIGH or LOW                   | 4.5   |     | 5.5  |  | 4.5   |   | ns    |       |
| t <sub>S(L)</sub>             | A or B to CP                              | 4.0   |     | 4.0  |  | 4.0   |   |       |       |
| t <sub>H(H)</sub>             | Hold Time, HIGH or LOW                    | 1.0   |     | 1.0  |  | 1.0   |   |       |       |
| t <sub>H(L)</sub>             | A or B to CP                              | 1.0   |     | 1.0  |  | 1.0   |   | ns    |       |
| t <sub>W(H)</sub>             | CP Pulse Width                            | 4.0   |     | 4.0  |  | 4.0   |   |       |       |
| t <sub>W(L)</sub>             | HIGH or LOW                               | 7.0   |     | 7.0  |  | 7.0   |   | ns    |       |
| t <sub>W(L)</sub>             | MR Pulse Width, LOW                       | 4.0   |     | 5.0  |  | 4.0   |   | ns    |       |
| t <sub>REC</sub>              | Recovery Time<br>MR to CP                 | 5.0   |     | 6.5  |  | 5.0   |   | ns    |       |

**Physical Dimensions** inches (millimeters) unless otherwise noted

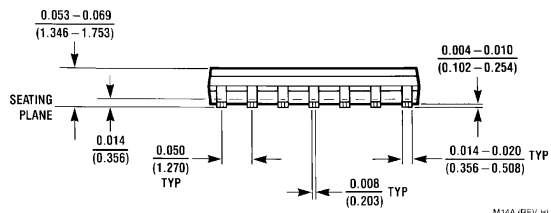
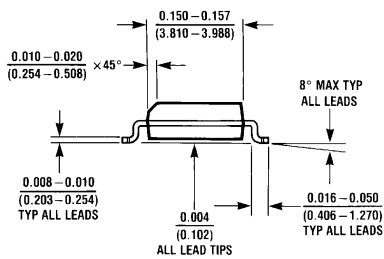
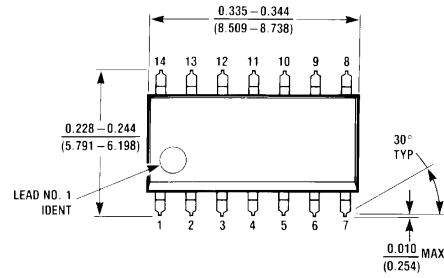

M14A (REV H)

**14-Lead Small Outline Integrated Circuit (SOIC), JEDEC MS-120, 0.150 Narrow Package Number M14A**

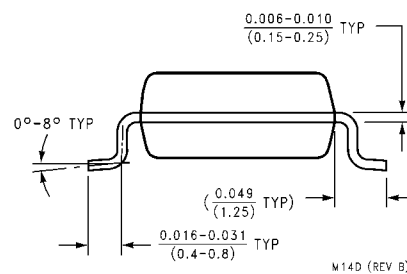
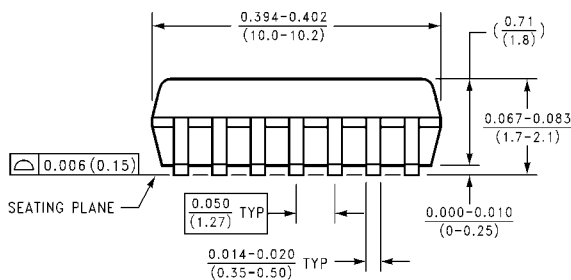
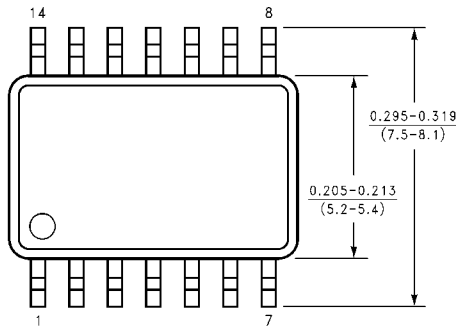

M14D (REV B)

**14-Lead Small Outline Package (SOP), EIAJ TYPE II, 5.3mm Wide Package Number M14D**

**Physical Dimensions** inches (millimeters) unless otherwise noted (Continued)



14-Lead Plastic Dual-In-Line Package (PDIP), JEDEC MS-001, 0.300 Wide Package Number N14A

Fairchild does not assume any responsibility for use of any circuitry described, no circuit patent licenses are implied and Fairchild reserves the right at any time without notice to change said circuitry and specifications.

**LIFE SUPPORT POLICY**

FAIRCHILD'S PRODUCTS ARE NOT AUTHORIZED FOR USE AS CRITICAL COMPONENTS IN LIFE SUPPORT DEVICES OR SYSTEMS WITHOUT THE EXPRESS WRITTEN APPROVAL OF THE PRESIDENT OF FAIRCHILD SEMICONDUCTOR CORPORATION. As used herein:

1. Life support devices or systems are devices or systems which, (a) are intended for surgical implant into the body, or (b) support or sustain life, and (c) whose failure to perform when properly used in accordance with instructions for use provided in the labeling, can be reasonably expected to result in a significant injury to the user.
2. A critical component in any component of a life support device or system whose failure to perform can be reasonably expected to cause the failure of the life support device or system, or to affect its safety or effectiveness.

[www.fairchildsemi.com](http://www.fairchildsemi.com)