

MAXIM

NiCd/NiMH Battery Fast-Charge Controllers

MAX2003/MAX2003A

General Description

The MAX2003/MAX2003A are fast-charge battery chargers (with conditioning) for NiCd (nickel cadmium) or NiMH (nickel-metal hydride) rechargeable batteries. The MAX2003A has the same features as the MAX2003 with an additional pulsed trickle-charge mode to prevent dendrite formation in NiMH batteries. Each can be configured as a switch-mode current regulator or as a gating controller for an external current source. Switch-mode current regulation provides efficient energy transfer, reducing power dissipation and the associated heating. Gating control of an external current source requires minimal components, saving space and cost.

On-chip algorithms determine charge termination, so the MAX2003/MAX2003A can be used as stand-alone chargers. Fast-charge termination is accomplished by five methods: temperature slope, negative voltage change, maximum temperature, maximum time, and maximum voltage. As a safety feature, the start of fast-charge is inhibited until battery voltage and temperature are within safe limits. By selecting the appropriate charge-termination method, a single circuit can be built with the MAX2003/MAX2003A to fast-charge both NiMH and NiCd batteries.

The MAX2003/MAX2003A provide a switch-activated discharge-before-charge option that allows for battery conditioning and more accurate capacity measurement. Other features include optional top-off charging and direct drivers for LED status lights.

The MAX2003, in DIP and wide SO packages, is a direct plug-in replacement for the bq2003. The MAX2003/MAX2003A also come in a space-saving narrow SO package. The MAX2003A evaluation kit (MAX2003A EVKIT-SO) is available to assist in designs.

Applications

Battery-Powered Equipment:

Laptop, Notebook, and Palmtop Computers
Handy-Terminals

Portable Consumer Products:

Portable Stereos
Cordless Phones

Backup-Battery Applications:

Memory Hold-Up
Emergency Switchovers

Features

- ♦ Stand-Alone NiCd or NiMH Fast Chargers
- ♦ New Pulsed Trickle-Charge Mode (MAX2003A only)
- ♦ Provide Switch-Mode, Gated, or Linear Control Regulation
- ♦ Small, Narrow SO Package Available
- ♦ On-Chip Fast-Charge Termination Methods:
 - Temperature Slope
 - Maximum Voltage
 - Negative Delta Voltage
 - Maximum Time
 - Maximum Temperature
- ♦ Automatically Switch from Fast-Charge to Trickle-Charge or Top-Off Charge
- ♦ Optional Discharge-Before-Charge
- ♦ Directly Drive Status LEDs
- ♦ Optional Top-Off Charge

Ordering Information

PART	TEMP. RANGE	PIN-PACKAGE
MAX2003CPE	0°C to +70°C	16 Plastic DIP
MAX2003CSE	0°C to +70°C	16 Narrow SO
MAX2003CWE	0°C to +70°C	16 Wide SO
MAX2003C/D	0°C to +70°C	Dice*
MAX2003ACPE	0°C to +70°C	16 Plastic DIP
MAX2003ACSE	0°C to +70°C	16 Narrow SO
MAX2003ACWE	0°C to +70°C	16 Wide SO
MAX2003AC/D	0°C to +70°C	Dice*

* Contact factory for dice specifications.

Pin Configuration

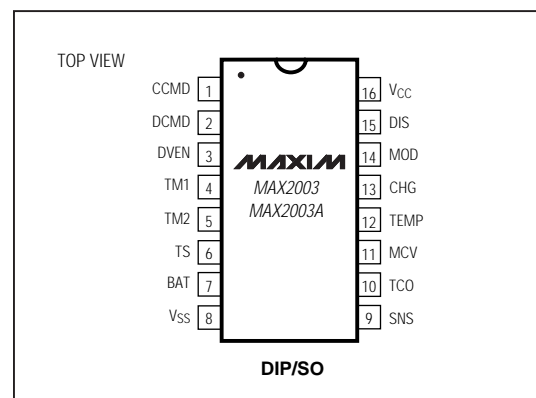

MAXIM

Maxim Integrated Products 1

For free samples & the latest literature: <http://www.maxim-ic.com>, or phone 1-800-998-8800.
For small orders, phone 1-800-835-8769.

NiCd/NiMH Battery Fast-Charge Controllers

ABSOLUTE MAXIMUM RATINGS

All Pins to V_{SS}-0.3V, +6.0V
 Continuous Power Dissipation ($T_A = +70^\circ\text{C}$)
 Plastic DIP (derate 10.53mW/ $^\circ\text{C}$ above $+70^\circ\text{C}$)842mW
 Narrow SO (derate 8.70mW/ $^\circ\text{C}$ above $+70^\circ\text{C}$)696mW
 Wide SO (derate 9.52mW/ $^\circ\text{C}$ above $+70^\circ\text{C}$).....762mW

Operating Temperature Range..... 0°C to $+70^\circ\text{C}$
 Storage Temperature Range -65°C to $+150^\circ\text{C}$
 Lead Temperature (soldering, 10sec) $+300^\circ\text{C}$

Stresses beyond those listed under "Absolute Maximum Ratings" may cause permanent damage to the device. These are stress ratings only, and functional operation of the device at these or any other conditions beyond those indicated in the operational sections of the specifications is not implied. Exposure to absolute maximum rating conditions for extended periods may affect device reliability.

ELECTRICAL CHARACTERISTICS

($V_{CC} = 4.5\text{V}$ to 5.5V , Figure 1, all measurements are with respect to V_{SS} , $T_A = T_{MIN}$ to T_{MAX} , unless otherwise noted.)

PARAMETER	SYMBOL	CONDITIONS	MIN	TYP	MAX	UNITS
Supply Voltage	V_{CC}		4.5	5.0	5.5	V
Supply Current	I_{CC}	No load		0.75	2.2	mA
Cell Potential	V_{CELL}	$V_{BAT} - V_{SNS}$	0.0		V_{CC}	V
Battery Voltage Input	V_{BAT}		0.0		V_{CC}	V
Temperature Potential	V_{TEMP}	$V_{TS} - V_{SNS}$	0.0		V_{CC}	V
Temperature Sense Input Voltage	V_{TS}		0.0		V_{CC}	V
End-of-Discharge Voltage	V_{EDV}	$V_{CC} = 5\text{V}$	$0.2V_{CC} - 30\text{mV}$	$0.2V_{CC}$	$0.2V_{CC} + 30\text{mV}$	V
Maximum Cell Voltage	V_{MCV}	$V_{CC} = 5\text{V}$	V_{EDV}		$V_{EDV} + 0.2V_{CC}$	V
Low-Temperature Trip Threshold	V_{LTF}	$V_{CC} = 5\text{V}$	$0.4V_{CC} - 30\text{mV}$	$0.4V_{CC}$	$0.4V_{CC} + 30\text{mV}$	V
Temperature Cutoff Voltage	V_{TCO}	$V_{CC} = 5\text{V}$	$V_{LTF} - 0.2V_{CC}$		V_{LTF}	V
High-Temperature Trip Threshold	V_{HTF}	$V_{CC} = 5\text{V}$, $V_{TCO} = 1.4\text{V}$	$\frac{(V_{LTF}/8)}{+ (7V_{TCO}/8)} - 30\text{mV}$	$\frac{(V_{LTF}/8)}{+ 7V_{TCO}/8}$	$\frac{(V_{LTF}/8)}{+ (7V_{TCO}/8)} + 30\text{mV}$	V
Sense Trip Threshold High	V_{SNSHI}	$V_{CC} = 5\text{V}$	$0.05V_{CC} - 25\text{mV}$	$0.05V_{CC}$	$0.05V_{CC} + 25\text{mV}$	V
Sense Trip Threshold Low	V_{SNSLO}	$V_{CC} = 5\text{V}$	$0.044V_{CC} - 25\text{mV}$	$0.044V_{CC}$	$0.044V_{CC} + 25\text{mV}$	V
Delta Sense Voltage (Note 1)	$V_{SNSHI} - V_{SNSLO}$			30		mV
Negative Delta Voltage (Note 2)	$-\Delta V$	$V_{CC} = 5\text{V}$		12		mV
Thermistor Input Resolution (Note 2)	V_{THERM}	$V_{CC} = 5\text{V}$		16		mV

NiCd/NiMH Battery Fast-Charge Controllers

MAX2003/MAX2003A

ELECTRICAL CHARACTERISTICS (continued)

($V_{CC} = 4.5V$ to $5.5V$, Figure 1, all measurements are with respect to V_{SS} , $T_A = T_{MIN}$ to T_{MAX} , unless otherwise noted.)

PARAMETER	SYMBOL	CONDITIONS	MIN	TYP	MAX	UNITS
Logic-High Threshold	V_{OH}	For DIS, TEMP and CHG, $0mA \leq I_{LOAD} \leq 5mA$; For MOD, $0mA \leq I_{LOAD} \leq 10mA$	$V_{CC} - 0.5$			V
Logic-Low Threshold	V_{OL}	For DIS, TEMP and CHG, $0mA \leq I_{LOAD} \leq 5mA$; For MOD, $0mA \leq I_{LOAD} \leq 10mA$		0.5		V
Input Logic Voltage High	V_{IH}	CCMD, DCMD, DVEN	$V_{CC} - 1.0$			V
		TM1, TM2	$V_{CC} - 0.3$			
Input Logic Voltage Low	V_{IL}	CCMD, DCMD, DVEN			1.0	V
		TM1, TM2			0.3	
Input Logic Leakage	I_{LKG}	CCMD, DCMD, DVEN at V_{CC} and V_{SS}	-1.0		1.0	μA
Input Logic Current High	I_{IH}	TM1, TM2 = V_{CC}	-70.0			μA
Input Logic Current Low	I_{IL}	TM1, TM2 = V_{SS}			70.0	μA
Input Logic Current High-Z	I_{IZ}	TM1, TM2 = tri-state	-2.0		2.0	μA
Input Impedance		BAT, MCV, TCO, SNS, TS	50			$M\Omega$

Note 1: The sense trip levels are determined by an internal resistor divider network that provides a typical difference of 30mV from SNSHI to SNSLO. Slight variation in this delta is seen if there is a resistor mismatch in the network.

Note 2: Typical variations of Negative Delta Voltage and Thermistor Input Resolution parameters are less than $\pm 4mV$.

TIMING CHARACTERISTICS

($V_{CC} = 4.5V$ to $5.5V$, Figure 1, all measurements are with respect to V_{SS} , $T_A = T_{MIN}$ to T_{MAX} , unless otherwise noted. Typical values are at $V_{CC} = 5.0V$, $T_A = +25^\circ C$.)

PARAMETER	SYMBOL	CONDITIONS	MIN	TYP	MAX	UNITS
Minimum Pulse Width	t_{MPW}	CCMD, DCMD	1.0			μs
Variation of Fast-Charge Timeout		(Note 3)	0.84	1.00	1.16	
MOD Switching Frequency	f_{MAX}	MOD pin in fast-charge mode, $V_{CC} = 5V$			100	kHz
Battery Replacement Timeout (Note 4)	t_{BTO}		200	250	300	ms

Note 3: Ratio of actual versus expected timeout (see Table 4). Tested with TM1 = TM2 = floating.

Note 4: To recognize a battery insert signal, V_{BAT} must be greater than V_{MCV} for at least t_{BTO} .

NiCd/NiMH Battery Fast-Charge Controllers

Pin Description

MAX2003/MAX2003A

PIN	NAME	FUNCTION
1	CCMD	Charge-Enabled Mode Input—initiates fast-charge on a digital signal (see <i>Detailed Description</i> for operating conditions).
2	DCMD	Discharge-Enable Mode Input—initiates discharge-before-charge on a digital signal (see <i>Detailed Description</i> for operating conditions).
3	DVEN	Negative Delta Voltage ($-\Delta V$) Enable Input—enables $-\Delta V$ charge-termination mode. If DVEN is high, the controller uses negative-voltage change detection to terminate charge. If DVEN is low, this mode is disabled.
4, 5	TM1, TM2	These inputs are used to program the fast-charge and hold-off times, and to enable the top-off charge mode. The inputs can be high, low, or floating. See Table 4 for details.
6	TS	Temperature Sense-Voltage Input from external thermistor. The thermistor temperature coefficient is negative, so the higher the temperature, the lower the voltage at this pin (See <i>Detailed Description</i> for conditions of operation).
7	BAT	Input Voltage of Single Battery Cell. If more than one cell is present, a resistor divider is needed to divide the voltage down to a single cell voltage.
8	V _{SS}	Ground
9	SNS	Current-Sense Input—connected to the negative battery terminal. TS and BAT are referenced to this pin. The voltage at SNS is directly proportional to the current through the battery and is used to determine how and when MOD switches.
10	TCO	Temperature Cutoff-Voltage Input. If the voltage from TS to SNS is less than the voltage at TCO, a hot thermistor (negative coefficient) is detected and fast or top-off charging is terminated.
11	MCV	Maximum Cell Voltage Input. If the voltage from BAT to SNS exceeds the voltage at MCV, fast or top-off charging is terminated.
12	TEMP	Temperature Status Output. This push/pull LED driver indicates that the temperature is outside the acceptable limits, and fast-charge and top-off are inhibited (see <i>Maximum Temperature Termination</i> section in <i>Detailed Description</i>).
13	CHG	Charge Status Output. This push/pull LED driver indicates charge status (see <i>Detailed Description</i>).
14	MOD	Modulation Output. This push/pull output switches to enable or disable charging current. If MOD is high, current is enabled. If it is low, current is disabled. For a 5V supply, if the voltage at the SNS pin is less than 220mV, MOD is high. If the voltage is above 250mV, MOD is low.
15	DIS	Discharge-Switch Control Output. This push/pull output turns on the FET that discharges the battery.
16	V _{CC}	Power-Supply Voltage Input (+5V nominal). Bypass with a 0.1 μ F capacitor placed close to the device.

NiCd/NiMH Battery Fast-Charge Controllers

MAX2003/MAX2003A

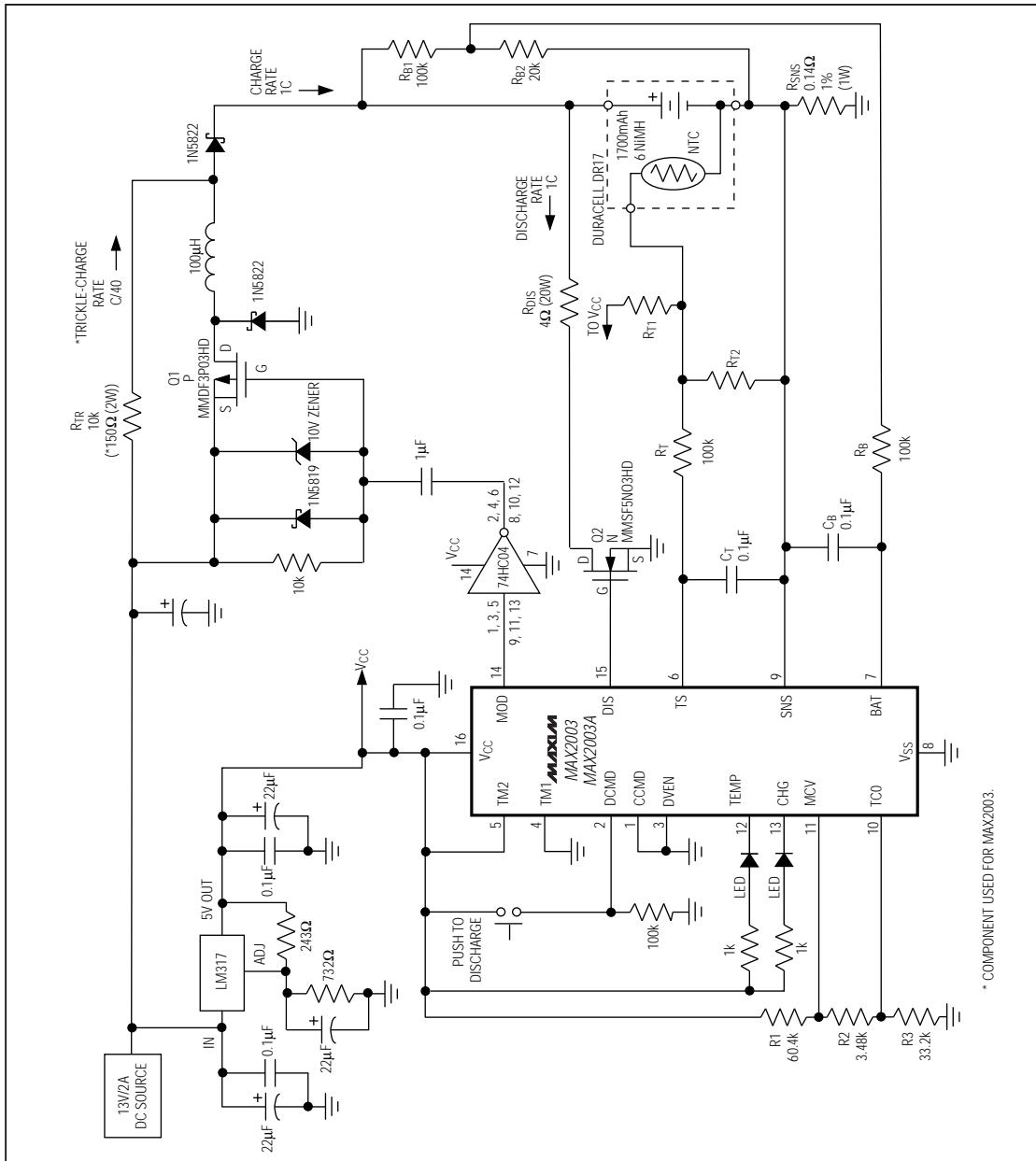

* COMPONENT USED FOR MAX2003.

Figure 1. Switched-Mode Operation for NiMH Batteries with $\Delta T/\Delta t$ Termination

NiCd/NiMH Battery Fast-Charge Controllers

Detailed Description

The MAX2003/MAX2003A is a fast-charge battery charger that uses several methods of charge termination. The device constantly monitors your choice of the following conditions to determine termination of fast-charge:

- Negative Delta Voltage ($-\Delta V$)
- Rate-of-Change of Temperature ($\Delta T/\Delta t$)
- Maximum Voltage
- Maximum Time
- Maximum Temperature

Figure 2 shows the block diagram for the MAX2003/MAX2003A.

The first step in creating a fast-charge battery-charger circuit is to determine what type of battery will be used and what conditions the battery manufacturer recommends for termination of fast-charge. The type of battery (NiCd or NiMH) and charge rate determine which method(s) of termination should be used.

The charging characteristics of NiMH batteries are similar to those of NiCd batteries, but there are some key differences that affect the choice of charge-termination method. Since the type of charge termination can be different for NiCd and NiMH batteries, it may not always be possible to use the same circuit for both battery types.

A comparison of the voltage profiles for NiCd and NiMH batteries (shown in Figure 3) reveals that NiCd batteries display a larger negative drop in voltage at the end of charge than do NiMH batteries. Therefore, the negative delta voltage detection ($-\Delta V$) method of terminating fast-charge should only be used for NiCd batteries. This termination method can cause errors in NiMH batteries, since the drop in voltage at full capacity is not as great, and may lead to an overcharged battery.

Figure 4 shows the temperature profiles of the two types of batteries. During the first 80% of the charge cycle, the NiCd battery temperature slowly rises. The NiMH battery temperature rises more rapidly during this period. As the cells approach 90% of capacity, the temperature of the NiCd cells rises more rapidly. When the cells approach full capacity, the rates-of-rise of temperature are comparable for both battery types. The rate of temperature change ($\Delta T/\Delta t$) can therefore be used to terminate fast-charge for both NiCd and NiMH batteries; fast-charge is terminated when the rate of temperature rise exceeds a preset rate.

Table 1 provides some guidelines to help in the selection of the proper fast-charge termination method, but the manufacturer's recommendations take priority in case of conflict.

Table 1a. Fast-Charge Termination Methods for NiMH Batteries

Charge Rate	$\Delta T/\Delta t$	Negative ΔV	Max Voltage	Max Time	Max Temp.
>C/2	Yes	No	Yes	Yes	Yes

Table 1b. Fast-Charge Termination Methods for NiCd Batteries

Charge Rate	$\Delta T/\Delta t$	Negative ΔV	Max Voltage	Max Time	Max Temp.
>2C	Yes	Yes	Yes	Yes	Yes
2C to C/2	*	*	Yes	Yes	Yes

* Use one or both of these termination methods.

Figure 1 shows a standard application circuit for a switched-mode battery charger that charges NiMH batteries at a rate of C. Though this circuit is shown for NiMH batteries, it can be used for NiCd batteries (see Table 1b). The description below will use this standard application to explain, in detail, the functionality of the MAX2003/MAX2003A.

Battery Sense Voltage

The BAT pin measures the per-cell voltage of the battery pack; this voltage is used to determine fast-charge initiation and termination. The voltage is determined by the resistor-divider combination R_{B1} and R_{B2} , shown in Figure 1, where:

$$\text{Total Number of Cells} = (R_{B1} / R_{B2}) + 1$$

Since BAT has extremely high input impedance (50M Ω minimum), reasonable values can be selected for resistors R_{B1} and R_{B2} . These values, however, must not be low enough to drain the battery or high enough to unduly lengthen the time constant of the signal going to the BAT pin. The total resistance value from the positive to negative terminal of the battery ($R_{B1} + R_{B2}$) should be between 100k Ω and 500k Ω to prevent these problems.

A simple RC lowpass filter (R_B , C_B) may be needed to give a more accurate reading by removing any noise that may be present. Remember that the RC time delay from the cell to BAT must not exceed 200ms or the battery detection logic might not function properly ($R_B \times C_B < 200\text{ms}$).

NiCd/NiMH Battery Fast-Charge Controllers

MAX2003/MAX2003A

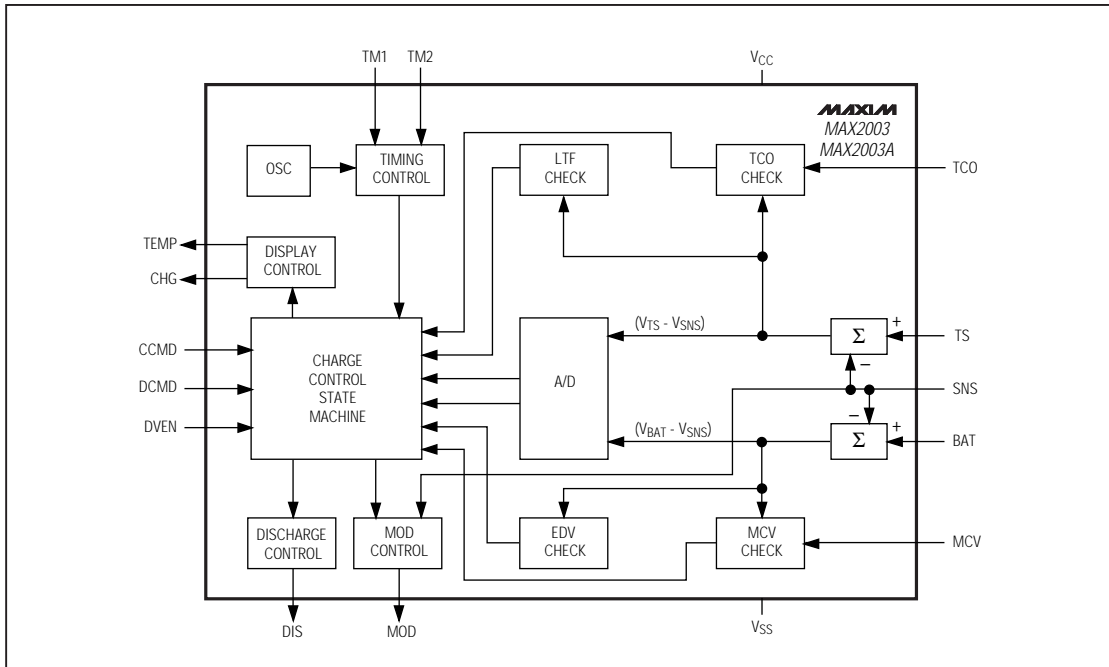

Figure 2. Block Diagram

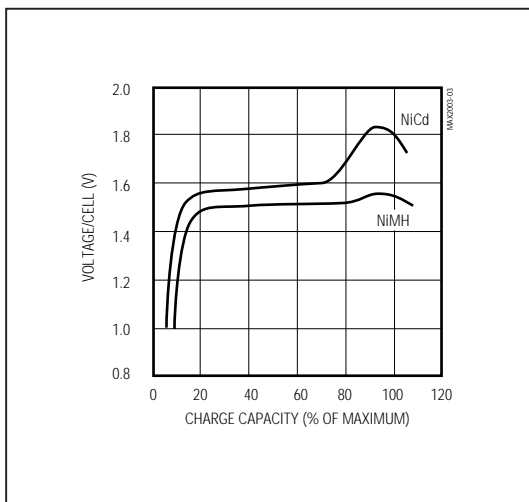

Figure 3. Voltage-Charge Characteristics of NiCd and NiMH Batteries

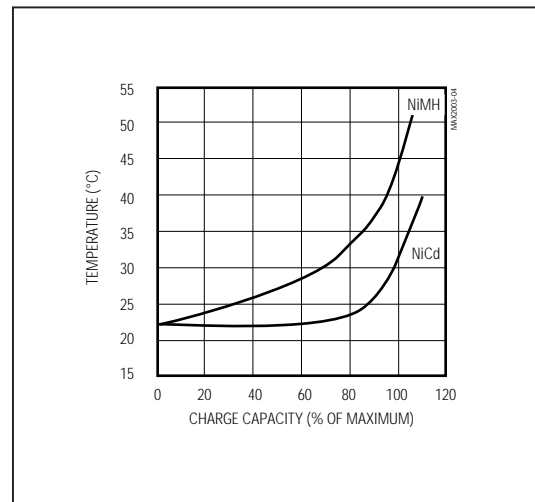

Figure 4. Temperature-Charge Characteristics of NiCd and NiMH Batteries

NiCd/NiMH Battery Fast-Charge Controllers

Temperature Measurement

The MAX2003/MAX2003A employs a negative temperature-coefficient (NTC) thermistor to measure the battery's temperature. This temperature value can be used to determine start and termination of fast-charge. The two temperature conditions that can be used for fast-charge termination are:

- Maximum Temperature
- Rate-of-Change of Temperature ($\Delta T/\Delta t$)

Figure 5 shows the various temperature cutoff points and the typical voltages that the device will see at the TS pin.

V_{LTF} (low-temperature fault voltage) refers to the voltage at TS when the battery temperature is too low, and V_{HTF} (high-temperature fault voltage) refers to the high-temperature cutoff. If the voltage is outside these limits, the MAX2003/MAX2003A will not enter fast-charge mode. After fast-charge is initiated, the termination point for high-temperature termination is V_{TCO} (temperature cutoff voltage), rather than V_{HTF} . See Figure 5 for TEMP LED status.

V_{LTF} is set internally at $0.4V_{CC}$, so (with a 5V supply) V_{LTF} is 2V. V_{TCO} is set up using external resistors to determine the high-temperature cutoff after fast-charge begins. V_{HTF} is internally set to be $(V_{LTF} - V_{TCO}) / 8$ above V_{TCO} .

Thermistors are inherently nonlinear with respect to temperature. This nonlinearity is especially noticed when $\Delta T/\Delta t$ measurements are made to determine charge termination. The simplest way around this is to place a resistor-divider network in parallel with the thermistor (Figure 6) to reduce the effects of nonlinearity.

The lowpass filter (R_T , C_T) placed on the TS pin attenuates high-frequency noise on the signal seen by TS.

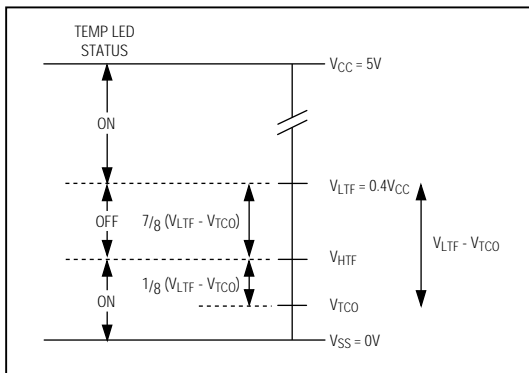

Figure 5. Temperature Measurement Scale

Charge Pending

Before fast-charge is initiated, the cell voltage and temperature of the battery pack must be within the assigned limits. If the voltage or temperature is outside these limits, the device is said to be in a "charge-pending" state. During this mode, the CHG pin will cycle low (LED on) for 0.125sec and high (LED off) for 1.375sec.

Fast-charge is normally initiated if the cell voltage is greater than V_{EDV} (end-of-discharge voltage). If the cell voltage is too low (below V_{EDV}), the device waits until the trickle current brings the voltage up before fast-charge is initiated. V_{EDV} is set internally at $0.2V_{CC}$, so (for a 5V supply) V_{EDV} is 1V.

If the temperature of the cell is not between V_{LTF} and V_{HTF} the device is also in a charge-pending state (see *Temperature Measurement* section).

Initiate Fast-Charge

If the MAX2003/MAX2003A are out of the charge-pending state, fast-charge can be initiated upon one of the following conditions:

- Battery Replacement
- Applying Power to the MAX2003/MAX2003A (battery already present)
- Digital Control Signal

During fast-charge, the CHG pin will be continuously low (LED on). For the initial period of fast-charge (the hold-off time), the voltage charge-termination methods are disabled. The hold-off time is a function of the charge rate selected by TM1 and TM2 (see Table 4).

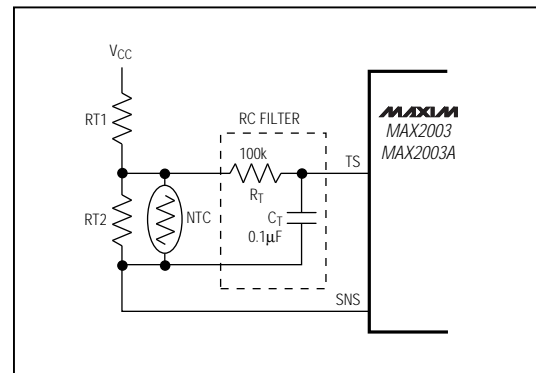

Figure 6. Thermistor Configuration for Temperature Measurement

NiCd/NiMH Battery Fast-Charge Controllers

Table 2. Device Status on Power-Up if Battery is Already Present

CCMD	DCMD	MAX2003/MAX2003A Status when Power is Applied
Low	Low	<ul style="list-style-type: none"> Fast-charge is initiated on power-up.
Low	High	<ul style="list-style-type: none"> The device does not enter fast-charge immediately. Fast-charge is initiated by the falling edge of a pulse on CCMD.
High	Low	<ul style="list-style-type: none"> The device does not enter fast-charge immediately. Fast-charge is initiated by the rising edge of a pulse on CCMD.
High	High	<ul style="list-style-type: none"> Fast-charge is initiated on power-up.

Battery Replacement

Before a battery is inserted, the BAT pin is pulled higher than the maximum cell voltage (MCV) by the resistor (R_{TR}) and the divider network (R_{B1}/R_{B2}) (Figure 1). When the battery is inserted, the voltage per cell at BAT falls from the default voltage to the battery voltage. Fast-charge is initiated on a falling edge when the BAT voltage crosses the voltage on MCV.

Applying Power to the MAX2003/MAX2003A (battery already present)



There may be some cases where a battery is connected before power is applied to the MAX2003/MAX2003A. When power is applied, the device goes into reset mode for approximately 1.5sec and then samples the CCMD and DCMD pins. Its charge status is determined by the voltage at both the CCMD and DCMD pins. Table 2 summarizes the various conditions the MAX2003/MAX2003A might see on power-up.

Table 2 shows that the MAX2003/MAX2003A can be set-up for fast-charge on power-up by making sure CCMD and DCMD are at the same potential. If fast-charge on power-up is not desired, make sure CCMD and DCMD are at different logic levels during power-up, and use a digital signal to control fast-charge (see *Digital Control* section).

Digital Control

The CCMD pin can be used to initiate fast-charge. This is useful when neither the power supply nor the battery can be removed from the charger. The CCMD signal needed to initiate fast-charge depends on the potential at DCMD. If DCMD is low, a rising edge on CCMD initiates fast-charge. If DCMD is high, a falling edge on CCMD provides the fast-charge signal. Table 3 summarizes the conditions used to start fast-charge.

Table 3. Digital Control of Fast-Charge (VCC and battery present)

CCMD	DCMD	CCMD Status to Initiate Fast-Charge
	Low	<ul style="list-style-type: none"> Fast-charge is initiated by a rising edge on CCMD.
	High	<ul style="list-style-type: none"> Fast-charge is initiated by a falling edge on CCMD.

Discharge-Before-Charge (optional)

The discharge-before-charge function is optional and can be used to condition old batteries. It is especially useful in NiCd batteries, since it alleviates the voltage depression problems associated with partially discharged NiCd cells. The discharge-before-charge function is initiated by a rising edge into DCMD.

When the digital signal is applied, the DIS pin will be pulled high, turning on the attached circuit and discharging its battery. The discharge process continues until the single cell voltage drops below 0.2V_{CC}. During the discharge phase, the CHG pin will be low (LED on) for 1.375sec and high (LED off) for 0.125sec.

The MAX2003/MAX2003A does not control the current during discharge-before-charge. If the discharge rate is too great, the battery could overheat and be damaged. The battery manufacturer will be able to specify a safe discharge rate, but a rate of C or slower is typically acceptable. It is also important to choose components (Q2, R_{DIS}) that are rated for that particular discharge rate. Since the gate-source drive for Q2 can be as low as 4.5V, use a logic-level MOSFET.

Fast-Charge Current

The fast-charge current can be generated using two categories of circuits:

- Circuits with a sense resistor (R_{SNS})
- Circuits without sense resistor (SNS tied to V_{SS})

Circuits with SNS Resistor

The standard application circuit of Figure 1 uses an inductor and a switched mode of operation to supply the current. The charge current is determined by the sense resistor placed between the negative terminal of the battery (SNS) and ground (V_{SS}).

The SNS pin is the input to a comparator with hysteresis. If the voltage at SNS drops below 0.044V_{CC}, the MOD pin is turned on. If the SNS voltage is above 0.050V_{CC}, MOD is turned off. In the switched mode of

NiCd/NiMH Battery Fast-Charge Controllers

operation, the SNS voltage ramps between $0.044V_{CC}$ and $0.050V_{CC}$, which is 220mV and 250mV when V_{CC} is 5V (Figure 7). The average voltage at SNS, therefore, is 235mV, and can be used to calculate the charge current as follows:

$$I_{CHARGE} = 0.235V / R_{SNS}$$

where R_{SNS} is the sense resistor and I_{CHARGE} is the charge current required.

Circuits without SNS Resistor

In some applications (shown later), SNS is tied directly to ground. In these cases, the MOD pin remains on until any one charge-termination condition is exceeded (Figure 8). A reasonable external current limit (such as a current-limited DC source) must be provided for these applications, to prevent battery damage due to excessive charge currents.

Charge Termination

The MAX2003 has several charge-termination methods. The termination method selected depends on the type of battery and charge rate used. Table 1 summarizes the conditions used to terminate fast-charge with different battery types and charge rates.

Temperature Rate Termination

The Temperature Rate Termination ($\Delta T/\Delta t$) method terminates fast-charge when a particular rate-of-change in temperature is exceeded. As the battery begins fast-charge, its temperature increases at a slow rate. When the battery nears full capacity, this rate of temperature change increases. When the rate of temperature change exceeds a preset number, fast-charge is terminated. This method of fast-charge termination can be used for both NiCd and NiMH batteries.

The MAX2003 samples the voltage at the TS pin every 34 seconds and compares it with a value taken 68 seconds earlier. Since an NTC thermistor is used for temperature measurements, a gradual rise in temperature will result in successively lower voltage readings. If the new reading is more than $0.0032V_{CC}$ (16mV for $V_{CC} = 5V$) below the old reading, fast-charge is terminated.

The MAX2003A varies the sampling interval as a function of charge rate (Table 4). As the charge rate increases, the sampling interval decreases, thereby allowing more accurate termination of fast charge.

Note: This method of charge termination is valid only when the battery's temperature is between V_{LTF} and V_{TCO} (Figure 5).

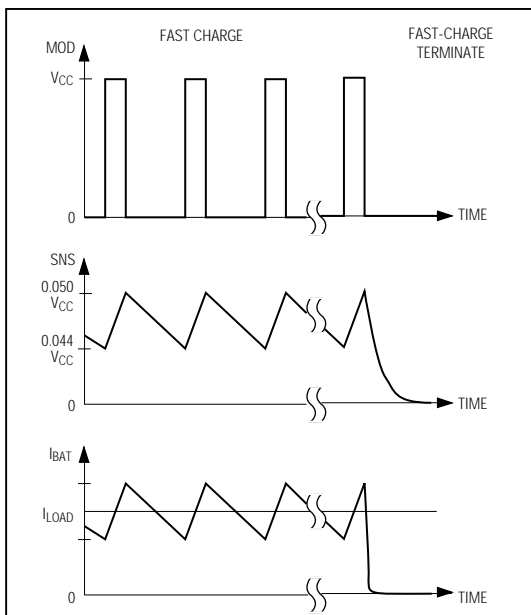

Figure 7. Current Regulation with an SNS Resistor

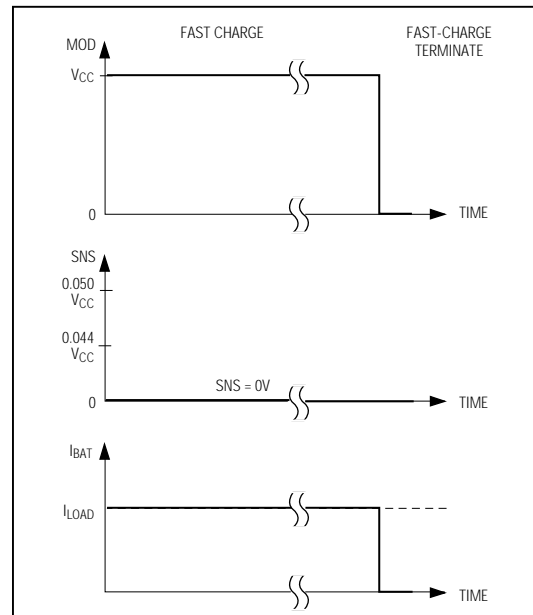

Figure 8. Current Regulation without an SNS Resistor

NiCd/NiMH Battery Fast-Charge Controllers

Negative Delta Voltage Termination

The Negative Delta Voltage Termination ($-\Delta V$) method measures a negative delta voltage to determine termination of fast-charge. After maximum charge is reached, the terminal voltage of NiCd batteries declines significantly, whereas the terminal voltage of NiMH batteries does not. Hence, the $-\Delta V$ method of fast-charge termination is suitable for NiCd batteries, but not for NiMH batteries.

The MAX2003/MAX2003A sample the BAT pin every 34 seconds and compare it with all previous values. If the new value is less than any of the previous values by more than 12mV, a negative delta voltage has been detected and fast-charge is terminated.

Note: This method of charge termination is valid only when the voltage at BAT is between V_{MCV} and $V_{MCV} - 0.2V_{CC}$.

The $-\Delta V$ method is inhibited during the hold-off time to prevent false termination of fast-charge. The hold-off time depends on the charge rate used, and is selected by the inputs TM1 and TM2 (as shown in Table 4). After the hold-off time has expired, the device begins to monitor BAT for a voltage drop.

Maximum Temperature Termination

The Maximum Temperature Termination method is used as a safety net to prevent problems, and should never be needed under normal operation of the charger. The maximum temperature that the battery can reach during fast-charge has a corresponding voltage—the temperature cutoff voltage (V_{TCO}), as seen in Figure 5. This voltage is set externally at the TCO pin using a resistor divider from V_{CC} . Although rarely experienced, an excessively low temperature will also terminate fast-charge. The minimum temperature is the low temperature fault (V_{LTF}). This value is internally set at $0.4V_{CC}$.

When the thermistor exceeds these temperature limits, fast-charge is terminated. The thermistor configuration shown in Figure 5 is used to measure the battery's temperature and scale it to operate from V_{LTF} to V_{TCO} . Resistors R_{T1} and R_{T2} are calculated to provide the required cutoff at V_{TCO} . See the *Design Guide* section for a detailed design example.

Maximum Voltage Termination

The Maximum Voltage Termination method is another safety feature designed to work if something is drastically wrong. Under normal operation of the charger, this condition should only be reached when the battery is removed.

The maximum cell voltage expected is applied at the MCV pin using a resistor-divider network. If the cell volt-

age measured at BAT exceeds that at MCV, fast-charge is terminated. For most applications using both NiCd and NiMH batteries, this voltage (V_{MCV}) can be set to 1.9V.

The MAX2003/MAX2003A do not terminate fast-charge if the maximum voltage is reached before the hold-off time has expired. If the cell voltage is greater than the MCV during the hold-off time, the device will continue fast-charge until the hold-off time has expired, and then it will terminate fast-charge. The hold-off time is determined by the inputs TM1 and TM2, as shown in Table 4.

Maximum Timeout Termination

The final method is Maximum Timeout Termination, which (like the maximum voltage and maximum temperature methods) is another backup safety feature. The timeout time depends on the charge rate selected and is set by the control signals TM1 and TM2. Table 4 shows a list of different timeout periods available for different control-signal inputs. If the timeout is reached before any other termination method is seen, fast-charge is terminated to protect the charger and battery.

Top-Off Charge

Top-off charge is used to provide the last bit of charge needed to reach full capacity after fast-charge is terminated. Top-off charging puts slightly more energy into the battery than simple trickle charging, and can be used for both NiCd and NiMH batteries. Select it by choosing the appropriate control signals on TM1 and TM2 (Table 4).

Table 4. Programmable Inputs for Timeout/Hold-Off/Fast-Charge/Top-Off/Pulse Trickle ($V_{CC} = 5V$)

TM1	TM2	Fast-Charge Rate	Fast-Charge Timeout (min)	Hold-Off Time $\Delta V/MCV$ (sec)	Top-Off Charge	MAX2003A Trickle Charge (s) On/Off	MAX2003A Sampling Interval (sec)
GND	GND	C/4	360	140	Disable	Disable	544
Open	GND	C/2	180	820	Disable	1 16	544
V_{CC}	GND	C	90	410	Disable	1 32	136
GND	Open	2C	45	200	Disable	1 64	68
Open	Open	4C	23	100	Disable	1 128	68
V_{CC}	Open	C/2	180	820	*Enable	0.5 16	544
GND	V_{CC}	C	90	410	*Enable	0.5 32	136
Open	V_{CC}	2C	45	200	*Enable	0.5 64	68
V_{CC}	V_{CC}	4C	23	100	*Enable	0.5 128	68

* MAX2003 is on for 4sec and off for 30sec.

MAX2003A is on for 0.5sec and off for 3.5sec.

NiCd/NiMH Battery Fast-Charge Controllers

Table 5. Charge Status

Charge State	CHG LED Status
Battery Absent	LED off
Charge Pending	LED on for 0.125sec, off for 1.375sec
Discharge-Before-Charge	LED on for 1.375sec, off for 0.125sec
Fast-Charge	LED on
Charge Complete and Top-Off	LED on for 0.125sec, off for 0.125sec

The top-off charge is done at 1/8 the fast-charge rate. For the MAX2003, the MOD pin is activated in every 34 second period to supply current to the battery for 4 seconds (MOD oscillates for 4 seconds and stays low for 30 seconds) (Figure 7). If external regulation is used (SNS tied to ground), MOD stays high for 4 seconds and low for 30 seconds (Figure 8). This top-off process continues until the fast-charge timeout (Table 4) is exceeded, or if a maximum temperature or maximum voltage condition is detected. The MAX2003A is slightly modified to turn the MOD pin on for 0.5sec in every 4 second period. This shorter on-time reduces battery heat and increases charge acceptance. During the top-off charge, the CHG pin will cycle low (LED on) for 0.125sec and high (LED off) for 0.125sec.

Trickle-Charge

A trickle-charge is applied to the battery after fast-charge and top-off charge have terminated to compensate for self discharge. There are two methods of trickle charge: constant and pulsed.

Pulsed Trickle-Charge (MAX2003A)

The MAX2003A provides a pulsed trickle-charge to the battery by turning on the MOD pin briefly during a fixed period of time. The duty cycle of the pulse is a function of the programmable inputs TM1 and TM2 (Table 4). The MAX2003A does not use the trickle resistor to provide the trickle charge. However, the trickle resistor cannot be entirely omitted because it is also used for the battery-detect circuitry.

Constant Trickle-Charge (MAX2003)

The MAX2003 provides a steady trickle-charge to the battery by connecting a resistor from the DC supply to the positive battery terminal. This resistor has a dual purpose, in that it provides a trickle-charge and pulls the BAT pin above the MCV when the battery is absent.

The trickle-charge rate depends on the type of battery used. For NiCd batteries, a nominal trickle-charge rate

would be C/16, and NiMH batteries could use a rate of C/40. The resistor value used depends on the maximum DC voltage and the typical battery voltage. For example, a six-cell 800mAh NiCd pack with a nominal voltage of 1.2V per cell would have a total voltage of 1.2V x 6V = 7.2V. If the DC supply voltage used is 14V, the voltage across the trickle resistor would be 14.0V - 7.2V = 6.8V. The trickle current needed would be C/16 = 800 / 16 = 50mA. The trickle resistor would therefore be $R_{TR} = 6.8V / 50mA \approx 150\Omega$. Similar calculations should be made for NiMH batteries using C/40 as the trickle-charge rate.

If a trickle-charge is not needed, a higher value of trickle resistor (like 100k Ω) can be selected to sense the battery insertion.

Charge Status

The CHG pin is connected to a LED that indicates the operating mode. Table 5 summarizes the different charge conditions.

Design Guide

Using the circuit of Figure 1 as an example, the following nine steps show how to design a 1.7A switch-mode fast-charger that can charge a Duracell DR17 (NiMH six-cell battery pack with a 1700mAh capacity).

1) Select DC Power Supply. The first step is to select the DC power supply (such as a wall cube). The minimum supply voltage should have a supply equal to about 2V per cell, plus 1V headroom for external circuitry ((2V/cell) + 1V). The minimum supply voltage must be greater than 6V. If, as in our example, there are six cells, a minimum supply of about 13V is needed ((6 cells x 2V) + 1V).

2) Determine Charge Rate. The charge rate, or fast-charge current (I_{FAST}), is determined by two factors: the capacity of the battery, and the time in which the user wants the battery to be charged. The battery manufacturer recommends a maximum fast-charge rate, which must not be exceeded.

$$I_{FAST} \text{ (mA)} = \frac{\text{Capacity of Battery (mAh)}}{\text{Charge Time (h)}}$$

For example, if a 1700mAh battery needs to be charged in two hours (C/2), a fast-charge current of at least 850mA is needed. A charge rate of C/2 will ideally charge a battery in two hours but, because of inefficiencies in a battery's chemical processes, the time could be 30% to 40% more. Our example circuit (Figure 1) charges the Duracell battery pack at a C rate of 1.7A, which should fully charge a discharged battery in approximately 80 minutes.

NiCd/NiMH Battery Fast-Charge Controllers

3) Select Sense Resistor. The sense resistor determines the rate at which the battery is fast-charged. The sense pin, SNS, has an average voltage of 235mV (see *Detailed Description*) and, since the charge current (I_{FAST}) is known from above, the resistor can be calculated by:

$$R_{SNS} = V_{SNS} / I_{FAST} = 0.235 / I_{FAST}$$

In this example, a fast-charge current of 1.7A requires a sense resistor of about 0.14 Ω (1 watt).

4) Select TM1 and TM2. Once the charge rate is determined, Table 4 can be used to select the TM1 and TM2 inputs. TM1 and TM2 set the safety timeout, hold-off time, and top-off enable (see *Fast-Charge Termination* section in the *Detailed Description*).

In Figure 1, a fast-charge rate of C with top-off would require TM1 to be GND and TM2 to be V_{CC} .

5) Select R_{B1} and R_{B2} . The MAX2003A requires the user to select R_{B1} and R_{B2} to indicate the number of cells in the battery. The total resistance value ($R_{B1} + R_{B2}$) should be between 100k Ω and 500k Ω to prevent any problems with noise. In Figure 1 (with six cells) R_{B1} is selected to be 100k Ω and, from the following equation:

$$R_{B2} = R_{B1} / (\text{Number of Cells} - 1) = 100k\Omega / (6 - 1)$$

R_{B2} can be calculated to be 20k Ω .

6) Select Temperature-Control Components. Most sealed rechargeable battery packs have a built-in thermistor to prevent air currents from corrupting the accurate temperature measurements. The thermistor size and temperature characteristics can be obtained from the battery-pack manufacturer, to help in designing the rest of the circuit. Three-terminal battery packs that incorporate a thermistor generally share a common connection for the thermistor and the battery negative terminal. Large charging currents may produce voltage drops across the common negative connector, causing errors in thermistor readings. Using separate contacts for the thermistor ground sense and the battery ground sense at the negative battery terminal will reduce these errors. If an external thermistor is to be used, take care to ensure that it is placed in direct contact with the battery, and that the battery/thermistor set-up is placed in a sealed container.

Neither NiCd nor NiMH batteries should be fast-charged outside the maximum and minimum temperature limits. However, some applications also require termination using the $\Delta T/\Delta t$ criterion. The resistors R_{T1} and R_{T2} (Figure 1) will determine the temperature cutoff (V_{TCO}) and the rate-of-change of temperature ($\Delta T/\Delta t$). Though NiCd batteries do not always require termination using the $\Delta T/\Delta t$ feature, it is not possible to isolate and disable this mode. It is therefore recommended

that NiCd and NiMH batteries use the same $\Delta T/\Delta t$ termination parameters.

The Duracell DR17 battery pack used in our example circuit recommended a low fault temperature (V_{LTF}) of +10°C and a maximum temperature cutoff (V_{TCO}) of +50°C. These maximum temperature values will never be reached in most cases, but are used as a safety net to prevent battery damage. According to Duracell, the 10k Ω thermistor inside the pack varies from 17.96k Ω at +10°C to 4.16k Ω at +50°C.

The circuit in Figure 1 will be designed so that a battery temperature change of 1°C/min will result in fast-charge termination. At 1°C/min, the battery will take 40 minutes to change 40°C (10°C to 50°C). Since a charge rate of C is used for this example, Table 4 shows that the MAX2003A samples the TS pin every 68 seconds and compares it with a value taken 136 seconds earlier. The device will terminate fast-charge if the voltage at TS changes by more than 0.0032 V_{CC} (16mV for $V_{CC} = 5V$). At a charge rate of 16mV every 136 seconds, the TS pin will charge 280mV in 40 minutes (40min x 60sec/min x 16mV/136sec).

The low fault temperature (V_{LTF}) is set internally at 0.4 V_{CC} , which is 2.0V for a supply of 5V. The temperature cutoff voltage (V_{TCO}) will be 280mV below V_{LTF} , or:

$$V_{TCO} = (2.00V - 0.28V) = 1.72V$$

Figure 5 shows that, at any given temperature:

$$V_{TS} = V_{CC} (R_{T2} \parallel R_{NTC}) / [(R_{T2} \parallel R_{NTC}) + R_{T1}]$$

When the battery temperature is +10°C, the voltage is:

$$V_{TS10} = V_{CC} (R_{T2} \parallel R_{NTC10}) / [(R_{T2} \parallel R_{NTC10}) + R_{T1}]$$

And at +50°C:

$$V_{TS50} = V_{CC} (R_{T2} \parallel R_{NTC50}) / [(R_{T2} \parallel R_{NTC50}) + R_{T1}]$$

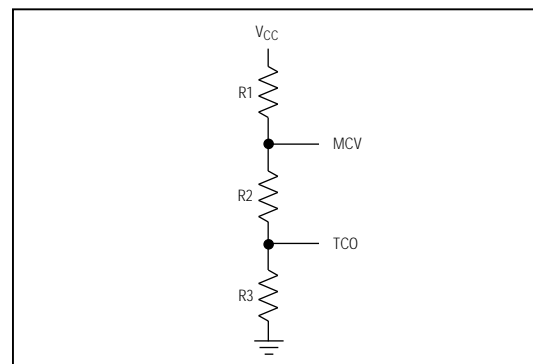

Figure 9. Resistor Configuration for MCV and TCO

NiCd/NiMH Battery Fast-Charge Controllers

From solving these simultaneous equations:

$$R_{T2} = [(X)(R_{NTC10}) - (R_{NTC50})] / (1 - X)$$

$$R_{T1} = [(R_{T2})(R_{NTC10})(V_{CC} - V_{TS10})] / [V_{TS10}(R_{T2} + R_{NTC10})]$$

$$\text{where } X = \frac{[(R_{NTC50})(V_{TS10})(V_{CC} - V_{TS50})]}{[(R_{NTC10})(V_{TS50})(V_{CC} - V_{TS10})]}$$

Using $R_{NTC50} = 4.16\text{k}\Omega$, $R_{NTC10} = 17.96\text{k}\Omega$, $V_{TS50} = 1.72\text{V}$, and $V_{TS10} = 2.00\text{V}$, it can be calculated that $R_{T1} = 1.599\text{k}\Omega$ and $R_{T2} = 2.303\text{k}\Omega$.

Select preferred resistor values for R_{T1} (2.21k Ω) and R_{T2} (1.62k Ω). The actual voltages on MCV and TCO can be verified as follows:

$$\begin{aligned} V_{TS10} &= \frac{V_{CC}(R_{T2} \parallel R_{NTC10})}{[(R_{T2} \parallel R_{NTC10}) + R_{T1}]} \\ &= \frac{5(1.62\text{k}\Omega \parallel 17.96\text{k}\Omega)}{[(1.62\text{k}\Omega \parallel 17.96\text{k}\Omega) + 2.21\text{k}\Omega]} \\ &= 2.01\text{V} \end{aligned}$$

$$\begin{aligned} V_{TS50} &= \frac{V_{CC}(R_{T2} \parallel R_{NTC50})}{[(R_{T2} \parallel R_{NTC50}) + R_{T1}]} \\ &= \frac{5(1.62\text{k}\Omega \parallel 4.16\text{k}\Omega)}{[(1.62\text{k}\Omega \parallel 4.16\text{k}\Omega) + 2.21\text{k}\Omega]} \\ &= 1.72\text{V} \end{aligned}$$

7) Select Maximum Cell Voltage (MCV) and Temperature Cutoff (TCO). The MCV and TCO can be selected with a resistor-divider combination (Figure 9). In our example, TCO has been set to +10°C, which corresponds to a voltage of 1.72V at the TS pin. The MCV for most fast-charge batteries can be set to about 1.9V. To minimize the current load on V_{CC} , choose R_1 in the range of 20k Ω to 200k Ω . In this example, choose $R_1 = 60.4\text{k}\Omega$, then calculate R_3 and R_2 as follows:

$$R_3 = (V_{TCO} \times R_1) / (V_{CC} - V_{MCV}) = 33.5\text{k}\Omega \text{ (1\%)} \\ \text{and}$$

$$R_2 = (V_{MCV} \times R_1) / (V_{CC} - V_{MCV}) - R_3 = 3.51\text{k}\Omega \text{ (1\%)}$$

Select preferred resistor values for R_2 (3.48k Ω) and R_3 (33.2k Ω). The actual voltages on MCV and TCO can be verified as follows:

$$V_{TCO} = V_{CC} (R_3) / (R_1 + R_2 + R_3) = 1.71\text{V} \\ \text{and}$$

$$V_{MCV} = V_{CC} (R_2 + R_3) / (R_1 + R_2 + R_3) = 1.89\text{V}$$

8) Select Trickle Resistor (MAX2003 only). The trickle resistor (R_{TR}) is selected to allow a trickle-charge rate of C/16 to C/40. The resistor value is given by:

$$R_{TR} = (V_{DC} - V_{BAT}) / I_{TR}$$

where I_{TR} is the required trickle current, V_{DC} is the DC supply voltage, and V_{BAT} is the number of cells times the cell voltage after fast-charge.

In our example, the 1700mAh NiMH battery needs a trickle current of C/40; i.e., 42mA (1700mAh/40h). Therefore, the minimum voltage (from the formula above) is as follows:

$$R_{TR} = [13.0\text{V} - (6 \times 1.2\text{V})] / 42\text{mA} \approx 150\Omega$$

The maximum power dissipated in the resistor can be calculated by:

$$\text{Power} = (V_{DC} - V_{BAT(\text{MIN})})^2 / R_{TR}$$

where $V_{BAT(\text{MIN})}$ is the minimum cell voltage, V_{DC} is the DC supply voltage, and R_{TR} is the trickle resistor value.

Since a shorted battery could have 0V, this must be the minimum cell voltage possible. Therefore the power dissipated in the trickle resistor would be:

$$\text{Power} = (13 - 0)^2 / 150 = 1.2\text{W}$$

A 2W, 150 Ω resistor should be sufficient for the trickle-charge resistor. For the MAX2003A, refer to *Trickle-Charge* section.

9) Select Inductor. The inductor value can be calculated using the formula:

$$V_L = L \delta / t$$

where V_L is the maximum voltage across the inductor, L is the minimum inductor value, δ is the change in inductor current, and t is the minimum on-time of the switch.

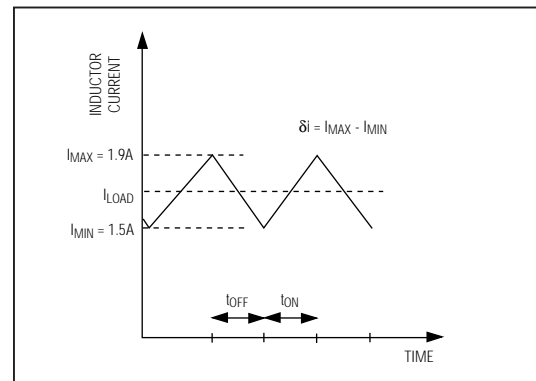

Figure 10. Inductor-Current Waveform in Continuous-Conduction Mode

NiCd/NiMH Battery Fast-Charge Controllers

In order to provide high currents with minimum ripple, the device must function in the continuous-conduction mode. Figure 10 shows a current waveform of an inductor in the continuous-conduction mode (where the coil current never falls to zero).

The average load current (I_{LOAD}) through the inductor must be 1.7A, so a peak current (I_{MAX}) of 1.9A should give a fairly low ripple while keeping the inductor size minimal. This means that the total current change (Figure 10) across the inductor is $\delta = 2 (1.9 - 1.7) = 0.4A$.

The maximum voltage across the inductor is present when the battery voltage is at its minimum. The minimum cell voltage at the start of fast-charge will be 1V per cell, giving a battery voltage of 6V for 6 cells. The maximum voltage (V_L) across the inductor is therefore:

$$V_L = (\text{input voltage} - \text{minimum battery voltage})$$

The input voltage for this application is 13V, so the maximum voltage is:

$$V_L = (13V - 6V) = 7V$$

The minimum on-time δ of the switch is given by:

$$\delta = (V_{OUT} / V_{IN}) \times \text{PERIOD}$$

where V_{OUT} is the minimum battery voltage, V_{IN} is the maximum input voltage, and PERIOD is the period of the switching signal.

The maximum input voltage for this application will be 14V, and the maximum allowed switching frequency of 100kHz gives a period of 10 μ s. The minimum on-time will therefore be:

$$\delta = (V_{OUT} / V_{IN}) \times \text{PERIOD} = (6V / 13V) \times 10\mu\text{s} = 4.62\mu\text{s}$$

The inductor value can be calculated from:

$$L = V \delta / \delta = (7V \times 4.62\mu\text{s}) / 0.4A = 81\mu\text{H}$$

Table 6. External Component Sources

Device	Manufacturer	Phone Number	Fax Number
Power Supply	Advanced Power Solutions	(510) 734-3060	(510) 460-5498
Thermistor	Alpha Thermistor	(800) 235-5445	(619) 549-4791
Power MOSFET & Darlington Transistor	Motorola	(602) 303-5454	(602) 994-6430
Battery	Duracell	(800) 431-2658	(203) 791-3273
	Energizer Power Systems	(904) 462-3911	(904) 462-4726

If this inductor value is used, the actual switching frequency will be lower than the 100kHz expected, due to comparator delays and variations in the duty cycle. The inductor value selected for our application will be 100 μ H—a preferred value just above the calculated value. It is important to choose the saturation current rating of the inductor to be a little higher than the peak currents, to prevent the inductor from saturating during operation. The inductor must be selected to ensure that the switching frequency of the MOD pin will not exceed the 100kHz maximum.

Additional Applications Information

The MAX2003/MAX2003A can use several other circuits to charge batteries. Figure 9 shows a circuit that uses a Darlington transistor to regulate the current a six-cell NiCd battery pack receives. Figure 10 shows a gated current-limited supply being used to charge a Duracell NiMH battery pack. Table 6 lists the external components used in these two application configurations.

Linear Regulation of Charge Current

The circuit in Figure 11 uses an inexpensive transistor to provide the charge current. Since the input for the MAX667 can tolerate up to 16V, this circuit can charge up to 7 cells. The MAX667 can be replaced with a different regulator if more cells need to be charged. The DC source must supply a voltage equal to 2x the number of cells, plus 2V overhead to accommodate the drop across external components.

When fast-charge is initiated, the voltage at the SNS pin is sampled and compared to the trip levels (220mV low and 250mV high). If the voltage at SNS is below 220mV, the MOD pin will switch high, and the 10k/1 μ F RC lowpass filter will pull high, turning on the NPN transistor. This will pull the base of the Darlington TIP115 low, turning it on and allowing current to flow into the battery. When the current through the battery and SNS resistor are high enough, the voltage at SNS will exceed 250mV and the MOD pin will turn off.

The amount of current the battery receives depends on the resistor between SNS and V_{SS} . In our example circuit, the average current through the SNS resistor will be:

$$I_{SNS(AVG)} = V_{SNS(AVG)} / R_{SNS} = 0.235 / 0.28 = 0.84A$$

The maximum current the resistor will receive is:

$$I_{SNS(MAX)} = V_{SNS(MAX)} / R_{SNS} = 0.25 / 0.28 = 0.90A$$

The Darlington transistor must be biased to ensure that a minimum of 0.90A will be supplied. This minimum

NiCd/NiMH Battery Fast-Charge Controllers

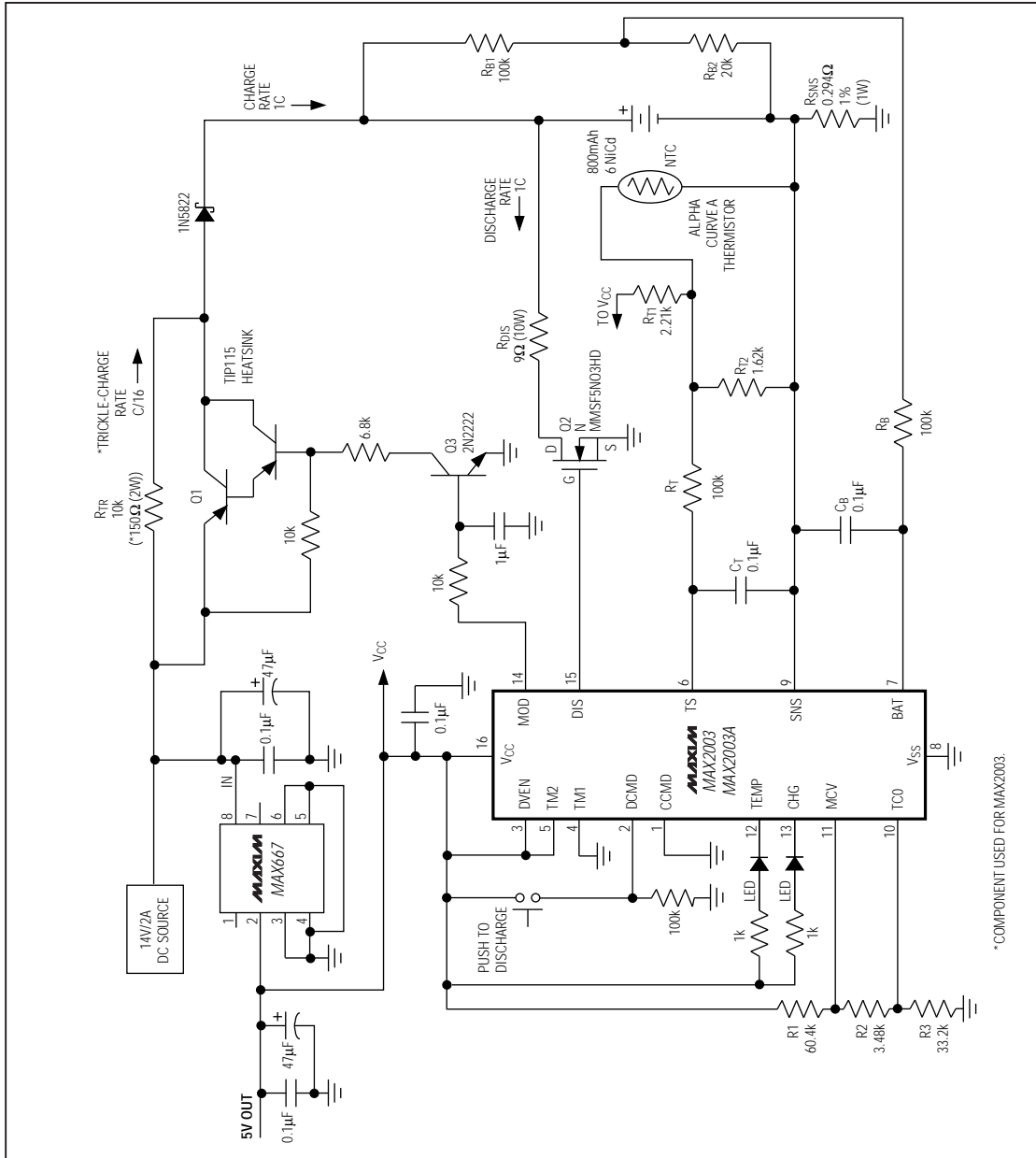
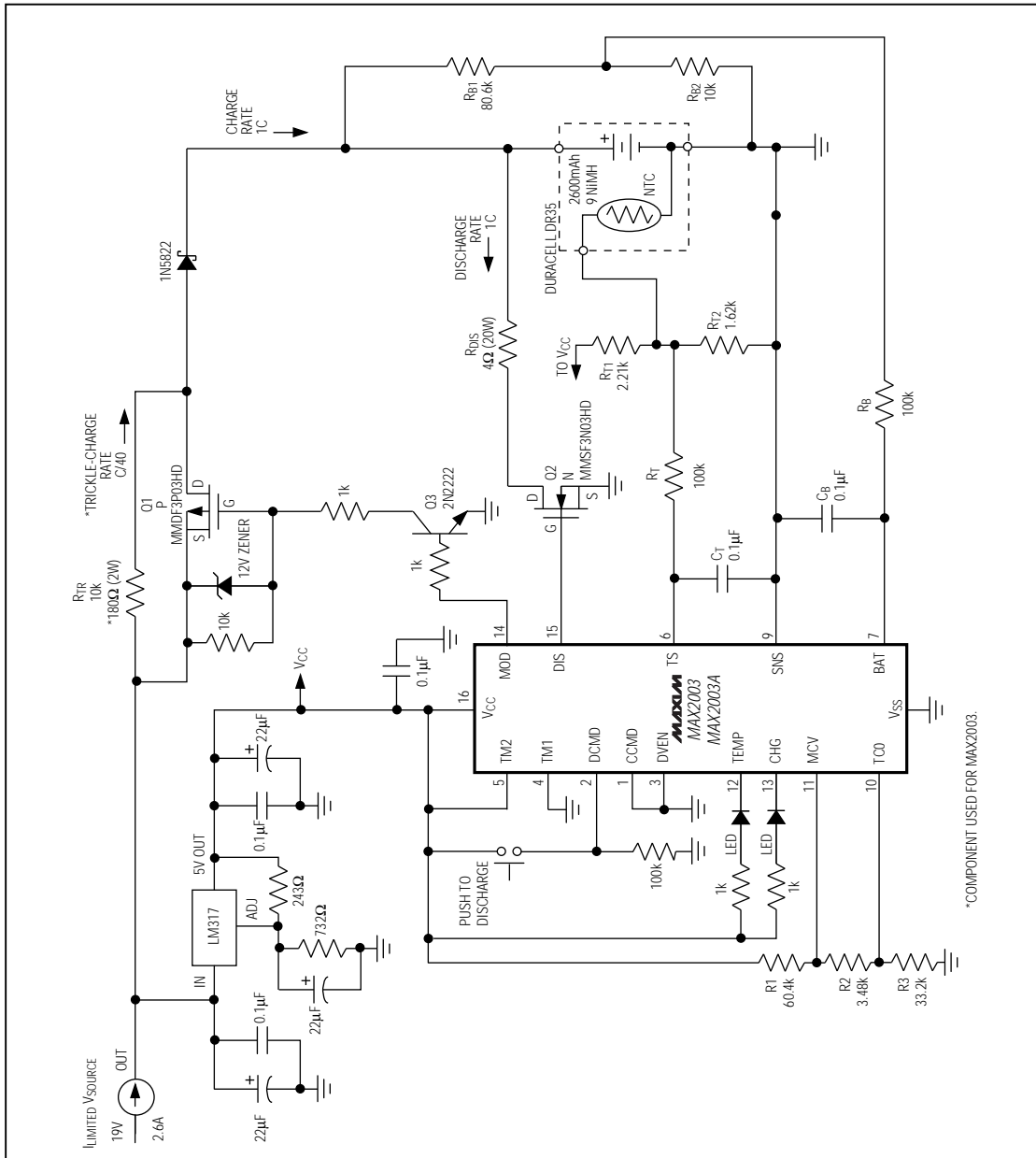

Figure 11. Linear Mode to Charge NiCd Batteries with -ΔV Termination

NiCd/NiMH Battery Fast-Charge Controllers

MAX2003/MAX2003A



*COMPONENT USED FOR MAX2003.

Figure 12. Current-Limited Mode for NiMH Batteries with $\Delta T/\Delta t$ Termination

NiCd/NiMH Battery Fast-Charge Controllers

current value must be sufficiently guardbanded to ensure the limiting factor is the SNS resistor, and not the transistor. In our example, the maximum current supplied by the Darlington will be guardbanded to 1.8A. Since the beta of the Darlington is typically 1000, the base current needed will be:

$$I_B = I_C / \text{BETA} = 1.8\text{A} / 1000 = 1.8\text{mA}$$

The emitter of the TIP115 will see 14V, so the base will see about 12.6V. When the MOD pin is high, the 2N2222 transistor is on and the base resistor will be:

$$R_B = V_B / I_B = 12.6\text{V} / 1.8\text{mA} \approx 6.8\text{k}\Omega$$

This 1.8A current will never be reached because MOD will be off when the SNS voltage reaches 0.25V (0.9A).

Current-Limited Supply

The circuit in Figure 12 is set up to charge a Duracell DR35 battery pack (nine cells, 2.6Ah) using a 19V, 2.6A current-limited power supply provided by Advanced Power Solutions. Since many power supplies have built-in current limiting, very few external components are required for this charging method.

The SNS pin in this circuit is tied directly to V_{SS} . This signals the MOD pin to stay high until a termination condition is met. When MOD is high, the NPN transistor is turned on, hence pulling the gate of the MOSFET low. This turns the MOSFET on and supplies current to the battery at the current limit of the source (2.6A). The 12V zener diode is placed between the source and gate of the FET to ensure the FET's maximum source-drain voltage is not exceeded.

When a termination condition is reached, the MOD pin goes low to turn off the FET and terminate the fast-charge current.

Table 7. Operation Summary

Charge Status	Conditions	MOD Status	DIS Status	CHG LED Status	
				LED On (Low) (sec)	LED Off (High) (sec)
Battery Absent	$(V_{BAT} - V_{SNS}) \geq V_{MCV}$	Low	Low	—	Continuous
Initiate Discharge	Rising edge on DCMD	Low	Low	—	Continuous
Initiate Fast-Charge	a) Power applied and voltage at CCMD = DCMD b) DCMD = Low, CCMD = Rising Edge (power already present) c) DCMD = High, CCMD = Falling Edge (power already present)	Low	Low	—	Continuous
Charge Pending	Fast-charge initiated and temperature or voltage outside the set limits.	Low	Low	0.125	1.375
Discharge	Discharge initiated with temperature and voltage within set limits.	Low	High	1.375	0.125
Fast-Charge	Fast-charge initiated with temperature and voltage within set limits.	If $V_{SNS} > 0.050V_{CC}$, MOD = Low If $V_{SNS} > 0.044V_{CC}$, MOD = High	Low	Continuous	—
Charge Complete	Exceed one of the five termination conditions.	Low	Low	0.125	0.125
Top-Off Charge	Charge complete and top-off enabled without exceeding temperature and voltage limits.	MAX2003A: Activate for 0.5sec in every 4sec period. MAX2003: Active for 4sec in every 34sec period.	Low	0.125	0.125
Constant Trickle-Charge (MAX2003)	Trickle current provided by external resistor after fast-charge/top-off.	Low	Low	0.125	0.125
Pulsed Trickle-Charge (MAX2003A)	Pulse current provided by pulsing MOD pin after fast-charge/top-off.	Pulsed according to charge rate (Table 4).	Low	0.125	0.125

NiCd/NiMH Battery Fast-Charge Controllers

MAX2003/MAX2003A

Chip Topography

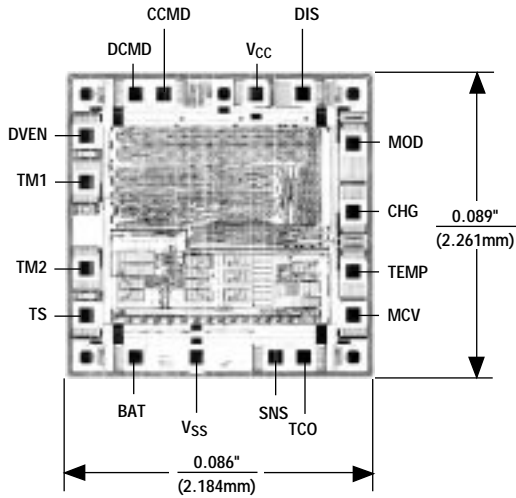

TRANSISTOR COUNT: 5514
SUBSTRATE CONNECTED TO Vss

Package Information

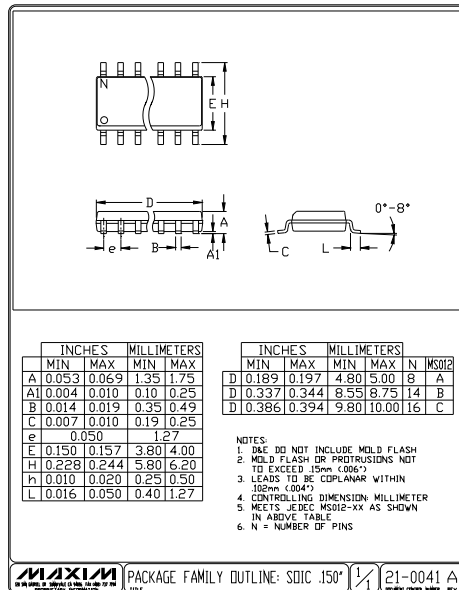

NiCd/NiMH Battery Fast-Charge Controllers

Package Information (continued)

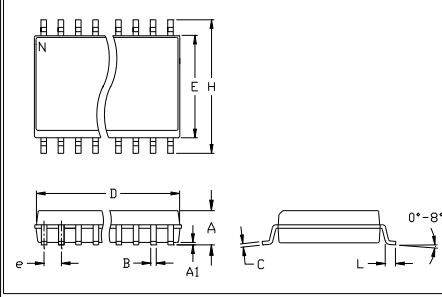

INCHES				MILLIMETERS							
	MIN	MAX	MIN	MAX							
A	0.093	0.104	2.35	2.65	D	0.398	0.413	10.10	10.50	16	AA
A1	0.004	0.012	0.10	0.30	D1	0.447	0.463	11.35	11.75	18	AB
B	0.014	0.019	0.35	0.49	D2	0.496	0.512	12.60	13.00	20	AC
C	0.009	0.013	0.23	0.32	D3	0.598	0.614	15.20	15.60	24	AD
e	0.050		1.27		D4	0.697	0.713	17.70	18.10	28	AE
E	0.291	0.299	7.40	7.60							
H	0.394	0.419	10.00	10.65							
h	0.010	0.030	0.25	0.75							
L	0.016	0.050	0.40	1.27							

NOTES:
 1. DAE DO NOT INCLUDE MOLD FLASH
 2. MOLD FLASH OR PROTRUSIONS NOT TO EXCEED .15mm (.006")
 3. LEADS TO BE COPLANAR WITHIN .102mm (.004")
 4. CONTROLLING DIMENSION: MILLIMETER
 5. MEETS JEDEC MS013-XX AS SHOWN IN ABOVE TABLE
 6. N = NUMBER OF PINS

MAXIM PACKAGE FAMILY OUTLINE: SOIC .300 21-0042 A

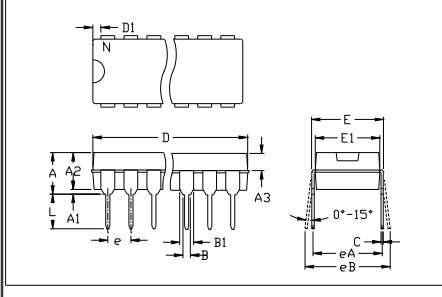

INCHES				MILLIMETERS							
	MIN	MAX	MIN	MAX							
A	---	0.200	---	5.08	D	0.348	0.390	8.84	9.91	8	AB
A1	0.015	---	0.38	---	D1	0.735	0.765	18.67	19.43	14	AC
A2	0.125	0.175	3.18	4.45	D2	0.745	0.765	18.92	19.43	16	AA
A3	0.055	0.080	1.40	2.03	D3	0.885	0.915	22.48	23.24	18	AD
B	0.016	0.022	0.41	0.56	D4	1.015	1.045	25.78	26.54	20	AE
B1	0.045	0.065	1.14	1.65	D5	1.14	1.265	28.96	32.13	24	AF
C	0.008	0.012	0.20	0.30	D6	1.360	1.380	34.54	35.05	28	AS
D1	0.005	0.080	0.13	2.03							
E	0.300	0.325	7.62	8.26							
E1	0.240	0.310	6.10	7.87							
e	0.100	---	2.54	---							
eA	0.300	---	7.62	---							
eB	---	0.400	---	10.16							
L	0.115	0.150	2.92	3.81							

NOTES:
 1. DAE DO NOT INCLUDE MOLD FLASH
 2. MOLD FLASH OR PROTRUSIONS NOT TO EXCEED .15mm (.006")
 3. CONTROLLING DIMENSION: MILLIMETER
 4. MEETS JEDEC MS001-XX AS SHOWN IN ABOVE TABLE
 5. SIMILAR TO JEDEC MO-058AB
 6. N = NUMBER OF PINS

MAXIM PACKAGE FAMILY OUTLINE: PDIP .300 21-0043 A