



CE (Low Voltage Directive)

Model name

PH 300 F 280-5

Output power Nominal input voltage
Name of series Function
F: Full function S: Simple function Nominal output voltage

Features

- CE marking (Low Voltage Directive)
- Compact DC-DC power module
Input: DC24V, DC48V, DC110V, DC280V
Output type: 50W, 75W, 100W, 150W, 300W
High power density: 31W/inch³ (300W type)
- Wide baseplate temperature: -20 ~ +85°C
Conduction cooling
- N+1 parallel redundant operation (F-type)
- 2 year warranty

Specifications

1. Input voltage range	DC24V input type: DC18 ~ 36V, DC48V input type: DC36 ~ 76V DC110V input type: DC82 ~ 185V, DC280V input type: DC200 ~ 400V
2. Output voltage range	F type: -60 ~ +20% (2V and 3V types: ±20%), S type: ±10% (By TRM terminal and external resistor) Output voltage range is different according to input voltage.
3. Parallel operation	F type: N+1 redundant operation. Output current balancing (PC terminal)
4. Line regulation	0.4%, within nominal input voltage range at constant load (3.3V output: 20mV)
5. Load regulation	0.8%, no load to full load at constant input voltage (3.3V output: 40mV)
6. Cooling	Conduction cooling (Heatsink & airflow has to be chosen according to instruction manual)
7. Operating ambient temperature	Baseplate temperature: -20 ~ +85°C (output derating is different according to condition) Ambient temperature: above -20°C
8. Withstand voltage	Input to output: 3.0kVAC, input to baseplate: 2.5kVAC for 1 min. (DC24V input type: input to output: 2.0kVAC, Input to baseplate: 2.0kVAC for 1 min.)
9. Safety standard	Approved by UL1950 , CSA950(C-UL) and EN60950 (BSI)
10. Functions	In all models: Over voltage protection, Over current protection, Thermal protection, ON/OFF control (CNT terminal) Additional in F type: Remote sensing, Remote on/off control (CNT terminal), Inverter good signal (IOG terminal), Auxiliary power supply for external signal (AUX terminal)

Power Module

Product lineup

Model name		Output voltage	Output current	Output power	UL	CSA	EN
PH50S24 (24Vin)	PH50S24-3.3	3.3V	10A	33W	Δ	Δ	Δ
	PH50S24-5	5V	10A	50W	Δ	Δ	Δ
	PH50S24-12	12V	4.2A	50.4W	Δ	Δ	Δ
	PH50S24-15	15V	3.4A	51W	Δ	Δ	Δ
	PH50S24-24	24V	2.1A	50.4W	Δ	Δ	Δ
PH100F24 (24Vin)	PH100F24-2	2V	20A	40W	Δ	Δ	Δ
	PH100F24-3	3V	20A	60W	Δ	Δ	Δ
	PH100F24-5	5V	20A	100W	Δ	Δ	Δ
	PH100F24-12	12V	8.4A	100.8W	Δ	Δ	Δ
	PH100F24-15	15V	6.7A	100.5W	Δ	Δ	Δ
PH300F24	PH300F24-24	24V	4.2A	100.8W	Δ	Δ	Δ
	PH300F24-28	28V	3.6A	100.8W	Δ	Δ	Δ
	PH50S48-3.3	3.3V	10A	33W	Δ	Δ	Δ
	PH50S48-5	5V	10A	50W	○	○	○
	PH50S48-12	12V	4.2A	50.4W	○	○	○
PH50S48 (48Vin)	PH50S48-15	15V	3.4A	51W	○	○	○
	PH50S48-24	24V	2.1A	50.4W	○	○	○
	PH50S48-28	28V	1.8A	50.4W	○	○	○
	PH75S48-3.3	3.3V	15A	49.5W	Δ	Δ	Δ
	PH75S48-5	5V	15A	75W	○	○	○
PH75S48 (48Vin)	PH75S48-12	12V	6.3A	75.6W	○	○	○
	PH75S48-15	15V	5A	75W	○	○	○
	PH75S48-24	24V	3.2A	76.8W	○	○	○
	PH75S48-28	28V	2.7A	75.6W	○	○	○

Model name		Output voltage	Output current	Output power	UL	CSA	EN
PH75F48 (48Vin)	PH75F48-2	2V	15A	30W	○	○	○
	PH75F48-3	3V	15A	45W	○	○	○
	PH75F48-5	5V	15A	75W	○	○	○
	PH75F48-12	12V	6.3A	75.6W	○	○	○
	PH75F48-15	15V	5A	75W	○	○	○
PH100S48 (48Vin)	PH75F48-24	24V	3.2A	76.8W	○	○	○
	PH75F48-28	28V	2.7A	75.6W	○	○	○
	PH100S48-3.3	3.3V	20A	66W	Δ	Δ	Δ
	PH100S48-5	5V	20A	100W	○	○	○
	PH100S48-12	12V	8.4A	100.8W	○	○	○
PH150S48 (48Vin)	PH100S48-15	15V	6.7A	100.5W	○	○	○
	PH100S48-24	24V	4.2A	100.8W	○	○	○
	PH100S48-28	28V	3.6A	100.8W	○	○	○
	PH150S48-3.3	3.3V	30A	99W	Δ	Δ	Δ
	PH150S48-5	5V	30A	150W	○	○	○
PH150F48 (48Vin)	PH150S48-12	12V	12.5A	150W	○	○	○
	PH150S48-15	15V	10A	150W	○	○	○
	PH150S48-24	24V	6.3A	151.2W	○	○	○
	PH150S48-28	28V	5.4A	151.2W	○	○	○
	PH150F48-2	2V	30A	60W	○	○	○
PH150F48 (48Vin)	PH150F48-3	3V	30A	90W	○	○	○
	PH150F48-5	5V	30A	150W	○	○	○
	PH150F48-12	12V	12.5A	150W	○	○	○
	PH150F48-15	15V	10A	150W	○	○	○
	PH150F48-24	24V	6.3A	151.2W	○	○	○
PH150F48-28	28V	5.4A	151.2W	○	○	○	

- Request customer specification for further details of specifications, outline, characteristics, etc. Read the instruction manual before usage.
- Contact us about delivery before ordering.

○ : Safety standard approved
Δ : Conforms to safety standard

● Recommended Heatsink P212

PH-SERIES

Product lineup

Model name	Output voltage	Output current	Output power	UL	CSA	EN	
PH300F48 (48Vin)	PH300F48-2	2V	60A	120W	○	○	○
	PH300F48-3	3V	60A	180W	○	○	○
	PH300F48-5	5V	60A	300W	○	○	○
	PH300F48-12	12V	25A	300W	○	○	○
	PH300F48-15	15V	20A	300W	○	○	○
	PH300F48-24	24V	12.6A	302.4W	○	○	○
PH300F48-28	28V	10.8A	302.4W	○	○	○	
PH50S110 (110Vin)	PH50S110-5	5V	10A	50W	○	○	○
	PH50S110-12	12V	4.2A	50.4W	○	○	○
	PH50S110-15	15V	3.4A	51W	○	○	○
	PH50S110-24	24V	2.1A	50.4W	○	○	○
	PH50S110-28	28V	1.8A	50.4W	○	○	○
PH75S110 (110Vin)	PH75S110-5	5V	15A	75W	○	○	○
	PH75S110-12	12V	6.3A	75.6W	○	○	○
	PH75S110-15	15V	5A	75W	○	○	○
	PH75S110-24	24V	3.2A	76.8W	○	○	○
	PH75S110-28	28V	2.7A	75.6W	○	○	○
PH75F110 (110Vin)	PH75F110-2	2V	15A	30W	○	○	○
	PH75F110-3	3V	15A	45W	○	○	○
	PH75F110-5	5V	15A	75W	○	○	○
	PH75F110-12	12V	6.3A	75.6W	○	○	○
	PH75F110-15	15V	5A	75W	○	○	○
PH150S110 (110Vin)	PH150S110-5	5V	30A	150W	○	○	○
	PH150S110-12	12V	12.5A	150W	○	○	○
	PH150S110-15	15V	10A	150W	○	○	○
	PH150S110-24	24V	6.3A	151.2W	○	○	○
	PH150S110-28	28V	5.4A	151.2W	○	○	○
PH150F110 (110Vin)	PH150F110-2	2V	30A	60W	○	○	○
	PH150F110-3	3V	30A	90W	○	○	○
	PH150F110-5	5V	30A	150W	○	○	○
	PH150F110-12	12V	12.5A	150W	○	○	○
	PH150F110-15	15V	10A	150W	○	○	○
PH300F110 (110Vin)	PH300F110-2	2V	60A	120W	○	○	○
	PH300F110-3	3V	60A	180W	○	○	○
	PH300F110-5	5V	60A	300W	○	○	○
	PH300F110-12	12V	25A	300W	○	○	○
	PH300F110-15	15V	20A	300W	○	○	○
PH300F110-24	PH300F110-24	24V	12.6A	302.4W	○	○	○
	PH300F110-28	28V	10.8A	302.4W	○	○	○

● Request customer specification for further details of specifications, outline, characteristics, etc.
Read the instruction manual before usage.
● Contact us about delivery before ordering.

Model name	Output voltage	Output current	Output power	UL	CSA	EN	
PH50S280 (280Vin)	PH50S280-3.3	3.3V	10A	33W	△	△	△
	PH50S280-5	5V	10A	50W	○	○	○
	PH50S280-12	12V	4.2A	50.4W	○	○	○
	PH50S280-15	15V	3.4A	51W	○	○	○
	PH50S280-24	24V	2.1A	50.4W	○	○	○
	PH50S280-28	28V	1.8A	50.4W	○	○	○
PH75S280 (280Vin)	PH75S280-3.3	3.3V	15A	49.5W	△	△	△
	PH75S280-5	5V	15A	75W	○	○	○
	PH75S280-12	12V	6.3A	75.6W	○	○	○
	PH75S280-15	15V	5A	75W	○	○	○
	PH75S280-24	24V	3.2A	76.8W	○	○	○
	PH75S280-28	28V	2.7A	75.6W	○	○	○
PH75F280 (280Vin)	PH75F280-2	2V	15A	30W	○	○	○
	PH75F280-3	3V	15A	45W	○	○	○
	PH75F280-5	5V	15A	75W	○	○	○
	PH75F280-12	12V	6.3A	75.6W	○	○	○
	PH75F280-15	15V	5A	75W	○	○	○
	PH75F280-24	24V	3.2A	76.8W	○	○	○
PH100S280 (280Vin)	PH100S280-3.3	3.3V	20A	66W	△	△	△
	PH100S280-5	5V	20A	100W	○	○	○
	PH100S280-12	12V	8.4A	100.8W	○	○	○
	PH100S280-15	15V	6.7A	100.5W	○	○	○
	PH100S280-24	24V	4.2A	100.8W	○	○	○
	PH100S280-28	28V	3.6A	100.8W	○	○	○
PH150S280 (280Vin)	PH150S280-3.3	3.3V	30A	99W	△	△	△
	PH150S280-5	5V	30A	150W	○	○	○
	PH150S280-12	12V	12.5A	150W	○	○	○
	PH150S280-15	15V	10A	150W	○	○	○
	PH150S280-24	24V	6.3A	151.2W	○	○	○
	PH150S280-28	28V	5.4A	151.2W	○	○	○
PH150F280 (280Vin)	PH150F280-2	2V	30A	60W	○	○	○
	PH150F280-3	3V	30A	90W	○	○	○
	PH150F280-5	5V	30A	150W	○	○	○
	PH150F280-12	12V	12.5A	150W	○	○	○
	PH150F280-15	15V	10A	150W	○	○	○
	PH150F280-24	24V	6.3A	151.2W	○	○	○
PH300F280 (280Vin)	PH300F280-2	2V	60A	120W	○	○	○
	PH300F280-3	3V	60A	180W	○	○	○
	PH300F280-5	5V	60A	300W	○	○	○
	PH300F280-12	12V	25A	300W	○	○	○
	PH300F280-15	15V	20A	300W	○	○	○
	PH300F280-24	24V	12.6A	302.4W	○	○	○
PH300F280-28	28V	10.8A	302.4W	○	○	○	

○ : Safety standard approved
△ : Conforms to safety standard

PH50S

PH75S

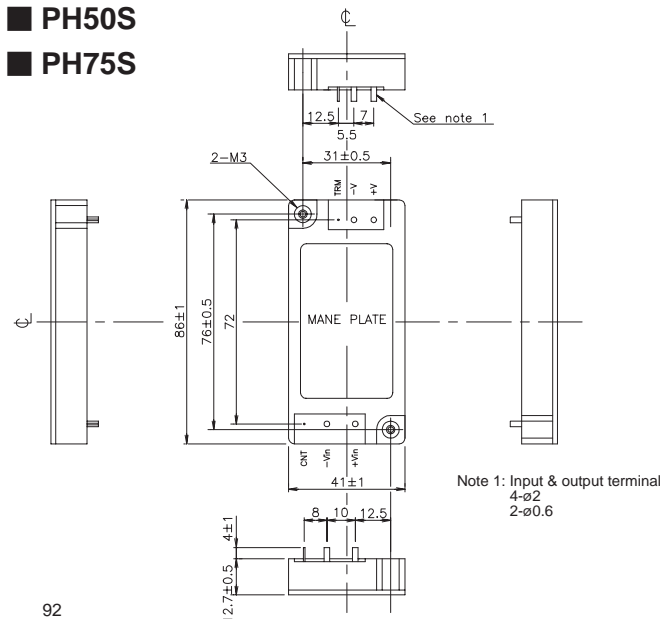

PH75F

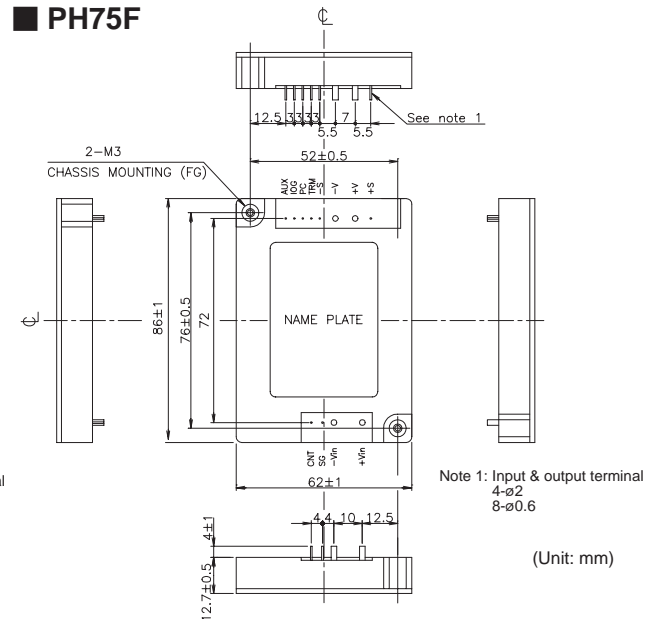

(Unit: mm)

PH100S

PH150S

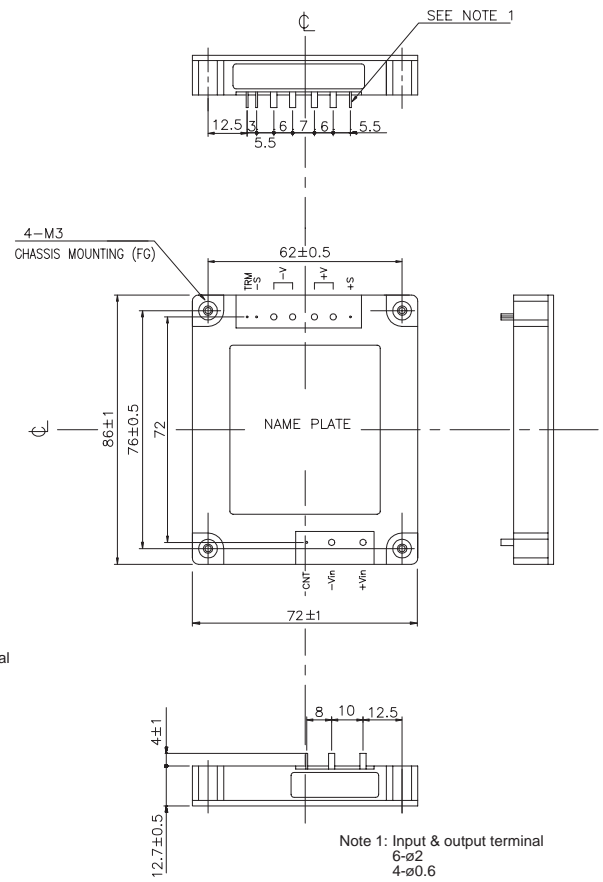
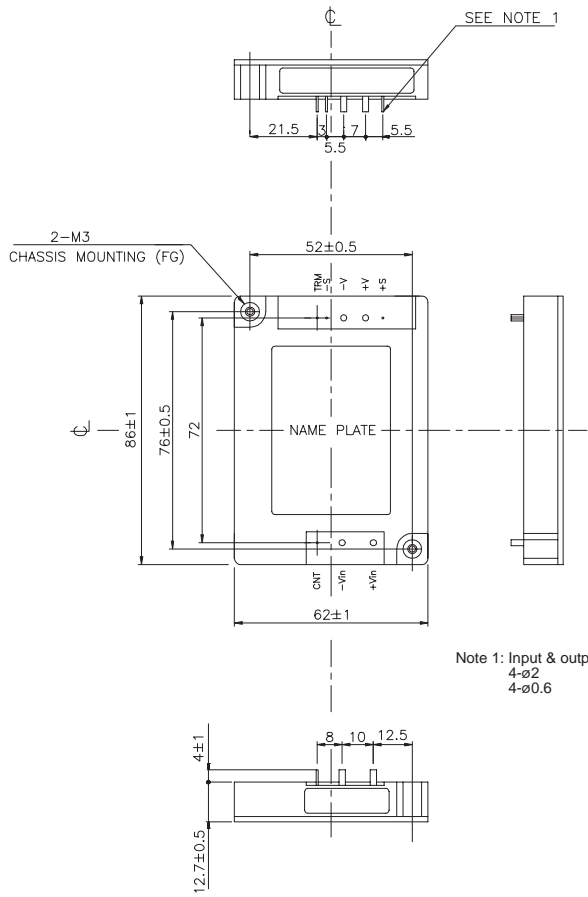

Power Module

PH100F

PH150F

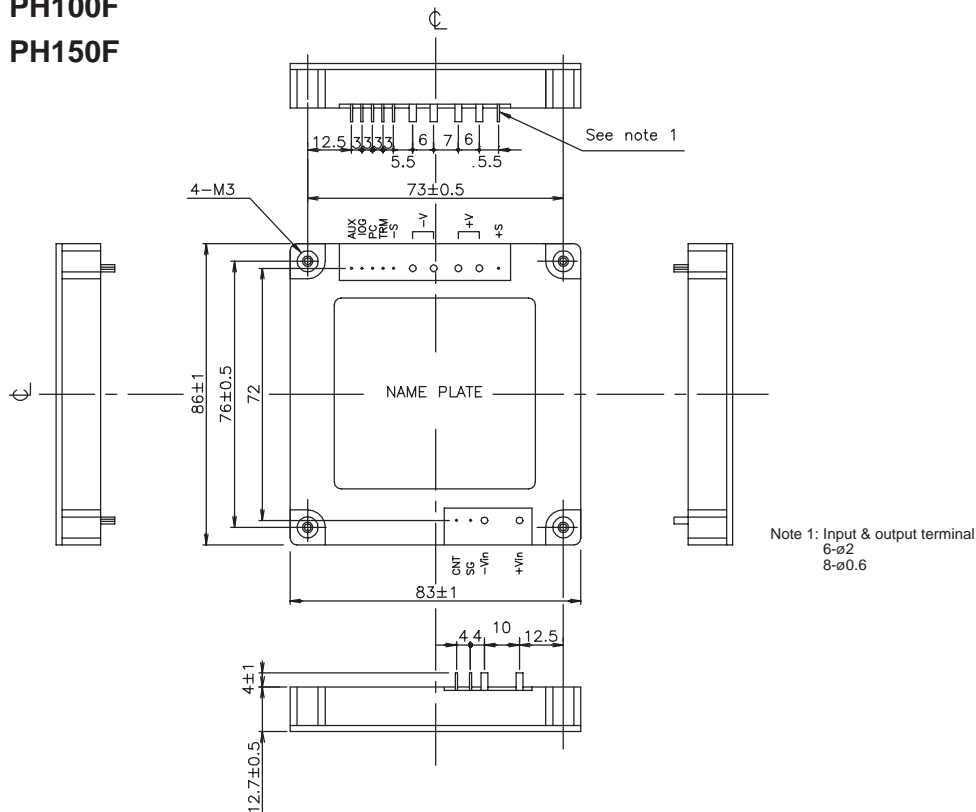

(Unit: mm)

PH-SERIES

■ PH300F

Power Module

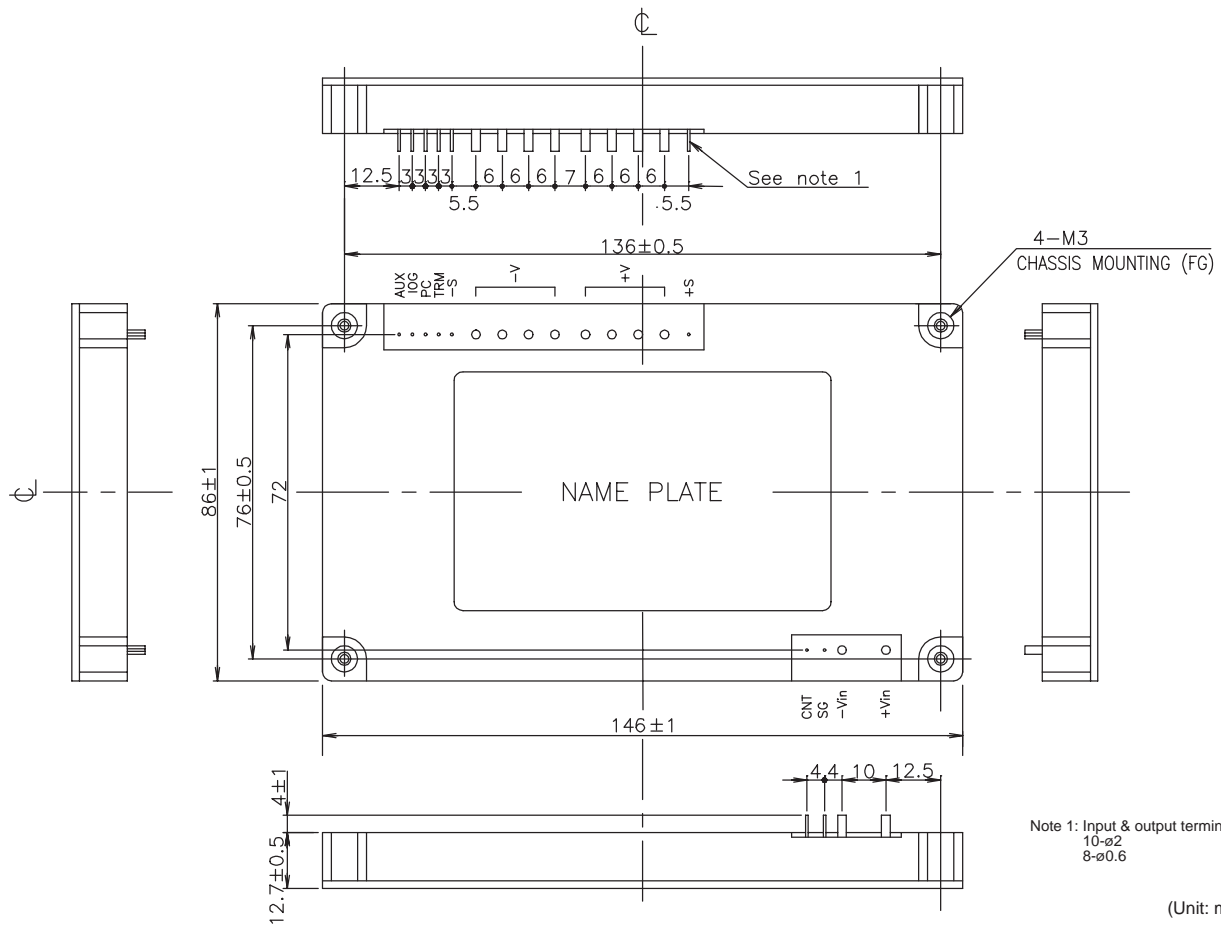

(Unit: mm)