

Legacy Device: Motorola MC3356

The ML3356 includes Oscillator, Mixer, Limiting IF Amplifier, Quadrature Detector, Audio Buffer, Squelch, Meter Drive, Squelch Status output, and Data Shaper comparator. The ML3356 is designed for use in digital data communications equipment.

- Data Rates up to 500 kilobaud
- Excellent Sensitivity: - 3 dB Limiting Sensitivity
30 μ Vrms @ 100 MHz
- Highly Versatile, Full Function Device, yet Few External Parts are Required
- Down Converter Can be Used Independently — Similar to NE602
- Operating Temperature Range $T_A = -40^\circ$ to $+85^\circ\text{C}$

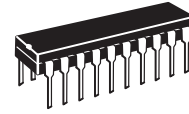

P DIP 20 = RP
PLASTIC PACKAGE
CASE 738

SO 20W = -6P
PLASTIC PACKAGE
CASE 751D
(SO-20L)

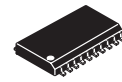

PACKAGE	MOTOROLA	LANSDALE
P DIP 20	MC3356P	ML3356RP
SO 20W	MC3356DW	ML3356-6P

Note: Lansdale lead free (Pb) product, as it becomes available, will be identified by a part number prefix change from ML to MLE.

Figure 1. Representative Block Diagram

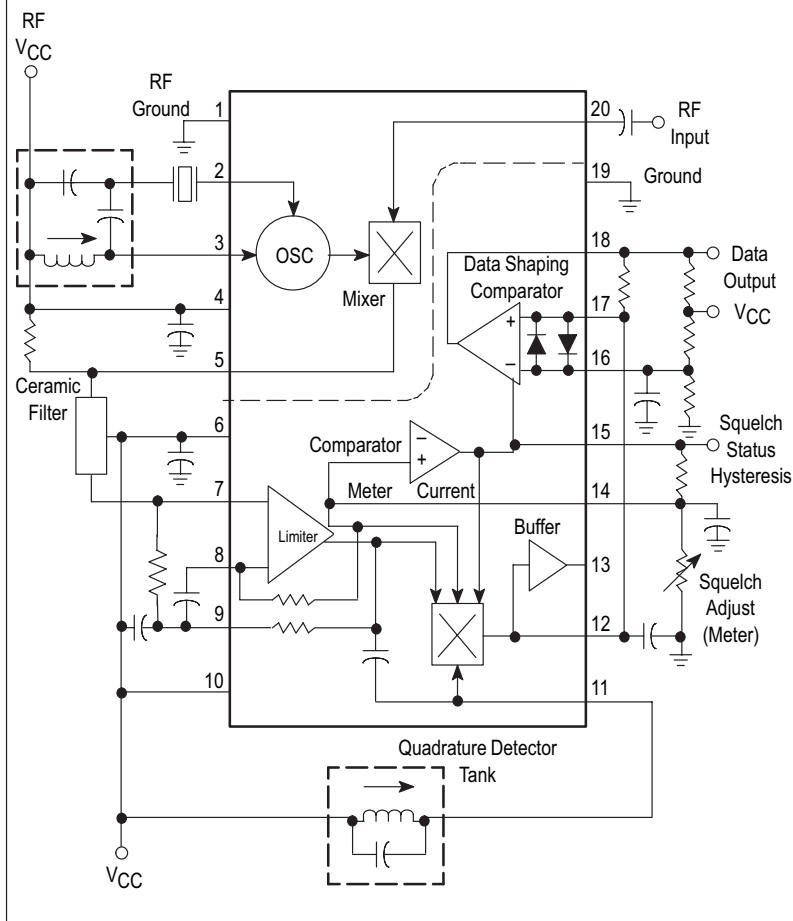

PIN CONNECTIONS

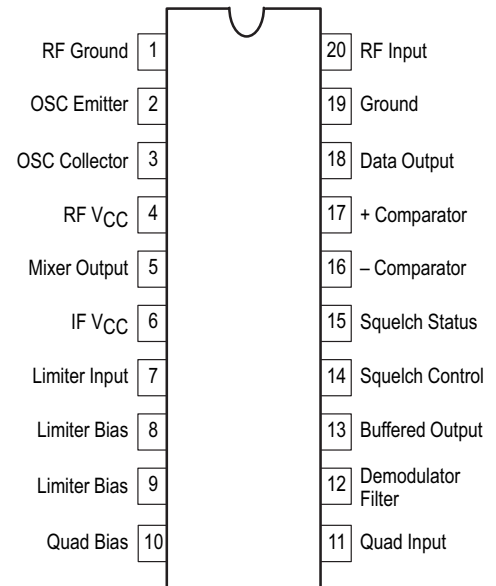

MAXIMUM RATINGS

Rating	Symbol	Value	Unit
Power Supply Voltage	V _{CC(max)}	15	Vdc
Operating Power Supply Voltage Range (Pins 6, 10)	V _{CC}	3.0 to 9.0	Vdc
Operating RF Supply Voltage Range (Pin 4)	RF V _{CC}	3.0 to 12.0	Vdc
Junction Temperature	T _J	150	°C
Operating Ambient Temperature Range	T _A	- 40 to + 85	°C
Storage Temperature Range	T _{stg}	- 65 to + 150	°C
Power Dissipation, Package Rating	P _D	1.25	W

ELECTRICAL CHARACTERISTICS (V_{CC} = 5.0 Vdc, f_o = 100 MHz, f_{osc} = 110.7 MHz, Δf = ±75 kHz, f_{mod} = 1.0 kHz, 50 Ω source, T_A = 25°C, test circuit of Figure 2, unless otherwise noted.)

Characteristics	Min	Typ	Max	Unit
Drain Current Total, RF V _{CC} and V _{CC}	-	20	25	mAdc
Input for - 3 dB limiting	-	30	-	μVrms
Input for 50 dB quieting ($\frac{S+N}{N}$)	-	60	-	μVrms
Mixer Voltage Gain, Pin 20 to Pin 5	2.5	-	-	V/V
Mixer Input Resistance, 100 MHz	-	260	-	Ω
Mixer Input Capacitance, 100 MHz	-	5.0	-	pF
Mixer/Oscillator Frequency Range (Note 1)	-	0.2 to 150	-	MHz
IF/Quadrature Detector Frequency Range (Note 1)	-	0.2 to 50	-	MHz
AM Rejection (30% AM, RF V _{in} = 1.0 mVrms)	-	50	-	dB
Demodulator Output, Pin 13	-	0.5	-	Vrms
Meter Drive	-	7.0	-	μA/dB
Squelch Threshold	-	0.8	-	Vdc

NOTE: 1. Not taken in Test Circuit of Figure 2; new component values required.

Figure 2. Test Circuit

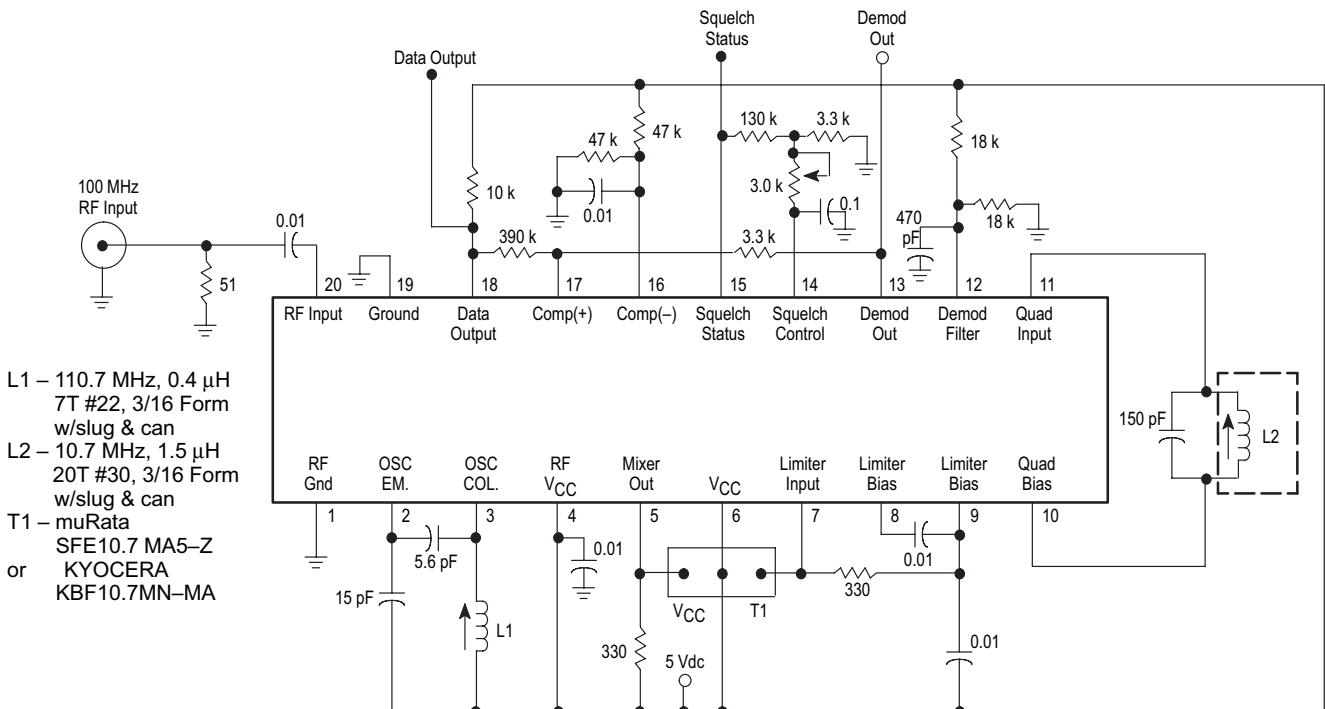

Figure 3. Output Components of Signal, Noise, and Distortion

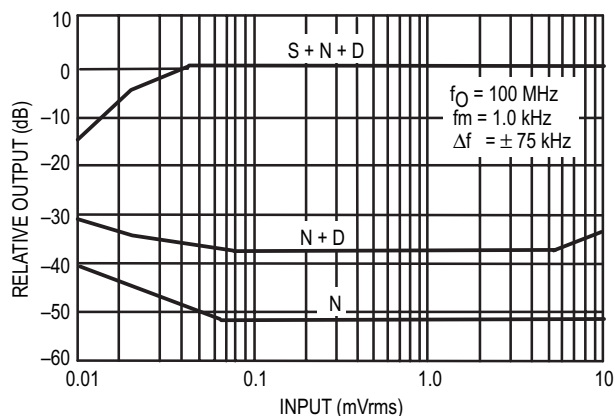
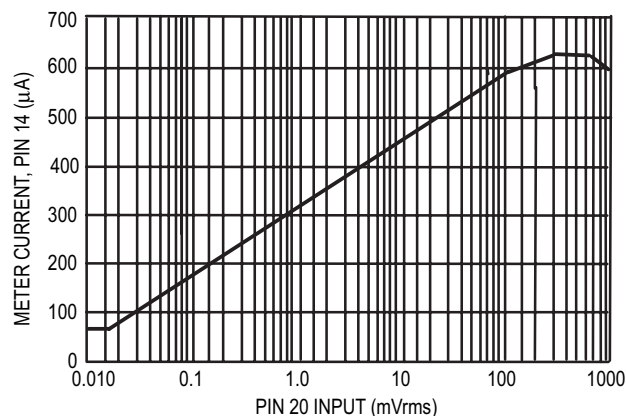

Figure 4. Meter Current versus Signal Input



GENERAL DESCRIPTION

This device is intended for single and double conversion VHF receiver systems, primarily for FSK data transmission up to 500 K baud (250 kHz). It contains an oscillator, mixer, limiting IF, quadrature detector, signal strength meter drive, and data shaping amplifier.

The oscillator is a common base Colpitts type which can be crystal controlled, as shown in Figure 1, or L-C controlled as shown in figure 8. At higher V_{CC} , it has been operated as high as 200 MHz. A mixer/oscillator voltage gain of 2 up to approximately 150 MHz, is readily achievable.

The mixer functions well from an input signal of 10 μ Vrms, below which the squelch is unpredictable, up to about 10 mVrms, before any evidence of overload. Operation up to 1.0 Vrms input is permitted, but non-linearity of the meter output is incurred, and some oscillator pulling is suspected. The AM rejection above 10 mVrms is degraded.

The limiting IF is a high frequency type, capable of being operated up to 50 MHz. It is expected to be used at 10.7 MHz in most cases, due to the availability of standard ceramic resonators. The quadrature detector is internally coupled to the IF, and a 5.0 pF quadrature capacitor is internally provided. The -3dB limiting sensitivity of the IF itself is approximately 50 μ V (at Pin 7), and the IF can accept signals up to 1.0 Vrms without distortion or change of detector quiescent DC level.

The IF is unusual in that each of the last 5 stages of the 6 state limiter contains a signal strength sensitive, current sinking device. These are parallel connected and buffered to produce a signal strength meter drive which is fairly linear for IF input signals of 10 μ V to 100 mVrms (see Figure 4).

A simple squelch arrangement is provided whereby the meter current flowing through the meter load resistance flips a comparator at about 0.8 Vdc above ground. The signal strength at which this occurs can be adjusted by changing the

meter load resistor. The comparator (+) input and output are available to permit control of hysteresis. Good positive action can be obtained for IF input signals of above 30 μ Vrms. The 130 k Ω resistor shown in the test circuit provides a small amount of hysteresis. Its connection between the 3.3k resistor to ground and the 3.0 k pot, permits adjustment of squelch level without changing the amount of hysteresis.

The squelch is internally connected to both the quadrature detector and the data shaper. The quadrature detector output, when squelched, goes to a DC level approximately equal to the zero signal level unsquelched. The squelch causes the data shaper to produce a high (V_{CC}) output.

The data shaper is a complete "floating" comparator, with back to back diodes across its inputs. The output of the quadrature detector can be fed directly to either input of this amplifier to produce an output that is either at V_{CC} or V_{EE} , depending upon the received frequency. The impedance of the biasing can be varied to produce an amplifier which "follows" frequency detuning to some degree, to prevent data pulse width changes.

When the data shaper is driven directly from the demodulator output, Pin 13, there may be distortion at Pin 13 due to the diodes, but this is not important in the data application. A useful note in relating high/low input frequency to logic state: low IF frequency corresponds to low demodulator output. If the oscillator is above the incoming RF frequency, then high RF frequency will produce a logic low (input to (+) input of Data Shaper as shown in Figures 1 and 2).

APPLICATION NOTES

The ML3356 is a high frequency/high gain receiver that requires following certain layout techniques in designing a stable circuit configuration. The objective is to minimize or eliminate, if possible, any unwanted feedback.

Legacy Applications Information

Figure 5. Application with Fixed Bias on Data Shaper

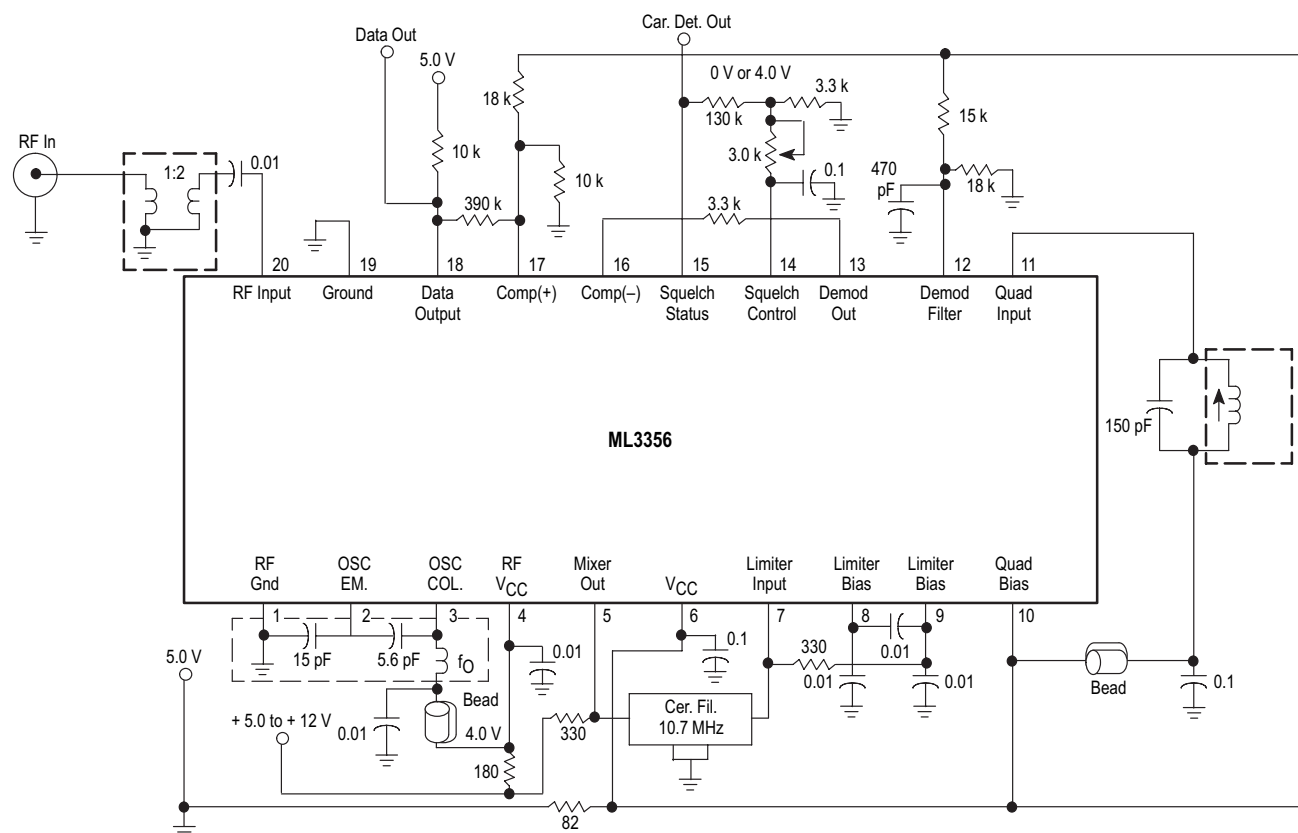

APPLICATION NOTES (continued)

Shielding, which includes the placement of input and output components, is important in minimizing electrostatic or electromagnetic coupling. The ML3356 has its pin connections such that the circuit designer can place the critical input and output circuits on opposite ends of the chip. Shielding is normally required for inductors in tuned circuits.

The ML3356 has a separate VCC and ground for the RF and IF sections which allows good external circuit isolation by minimizing common ground paths.

Note that the circuits of Figures 1 and 2 have RF, Oscillator, and IF circuits predominantly referenced to the plus supply rails. Figure 5, on the other hand, shows a suitable means of ground referencing. The two methods produce identical results when carefully executed. It is important to treat Pin 19 as a ground node for either approach. The RF input should be "grounded" to Pin 1 and then the input and the mixer/oscillator grounds (or RF VCC bypasses) should be connected by a

low inductance path to Pin 19. IF and detector sections should also have their bypasses returned by a separate path to Pin 19. VCC and RF VCC can be decoupled to minimize feedback, although the configuration of Figure 2 shows a successful implementation on a common 5.0 V supply. Once again, the message is: define a supply node and a ground node and return each section to those nodes by separate, low impedance paths.

The test circuit of Figure 2 has a 3 dB limiting level of 30 μV which can be lowered 6 db by a 1:2 untuned transformer at the input as shown in Figures 5 and 6. For applications that require additional sensitivity, an RF amplifier can be added, but with no greater than 20 db gain. This will give a 2.0 to 2.5 μV sensitivity and any additional gain will reduce receiver dynamic range without improving its sensitivity. Although the test circuit operates at 5.0 V, the mixer/oscillator optimum performance is at 8.0 V to 12 V. A minimum of 8.0 V is recommended in high frequency applications (above 150 MHz), or in PLL applications where the oscillator drives a prescaler.

Legacy Applications Information

Figure 6. Application with Self-Adjusting Bias on Data Shaper

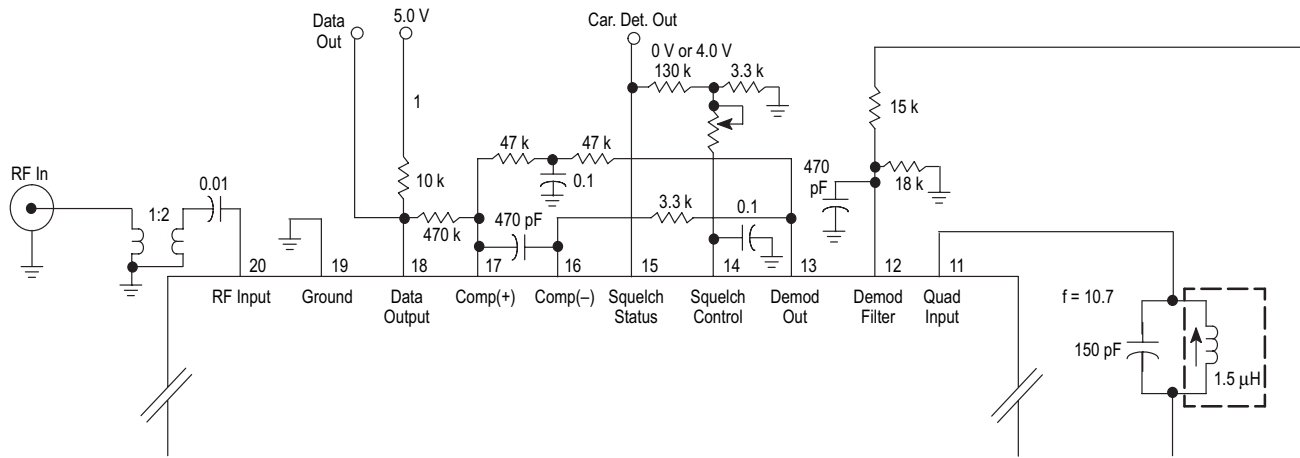

APPLICATION NOTES (continued)

Depending on the external circuit, inverted or noninverted data is available at Pin 18. Inverted data makes the higher frequency in the FSK signal a "one" when the local oscillator is above the incoming RF. Figure 5 schematic shows the comparator with hysteresis. In this circuit the DC reference voltage at Pin 17 is about the same as the demodulated output voltage (Pin 13) when no signal is present. This type circuit is preferred for systems where the data rates can drop to zero. Some systems have a low frequency limit on the data rate, such as systems using the MC3850 ACIA that has a start or

stop bit. This defines the low frequency limit that can appear in the data stream. Figure 5 circuit can then be changed to a circuit configuration as shown in Figure 6. In Figure 6 the reference voltage for the comparator is derived from the demodulator output through a low pass circuit where τ is much lower than the lowest frequency data rate. This and similar circuits will compensate for small tuning changes (or drift) in the quadrature detector.

Squelch status (Pin 15) goes high (squelch off) when the input signal becomes greater than some preset level set by the resistance between Pin 14 and ground. Hysteresis is added to the circuit externally by the resistance from Pin 14 to Pin 15.

Figure 7. Internal Schematic

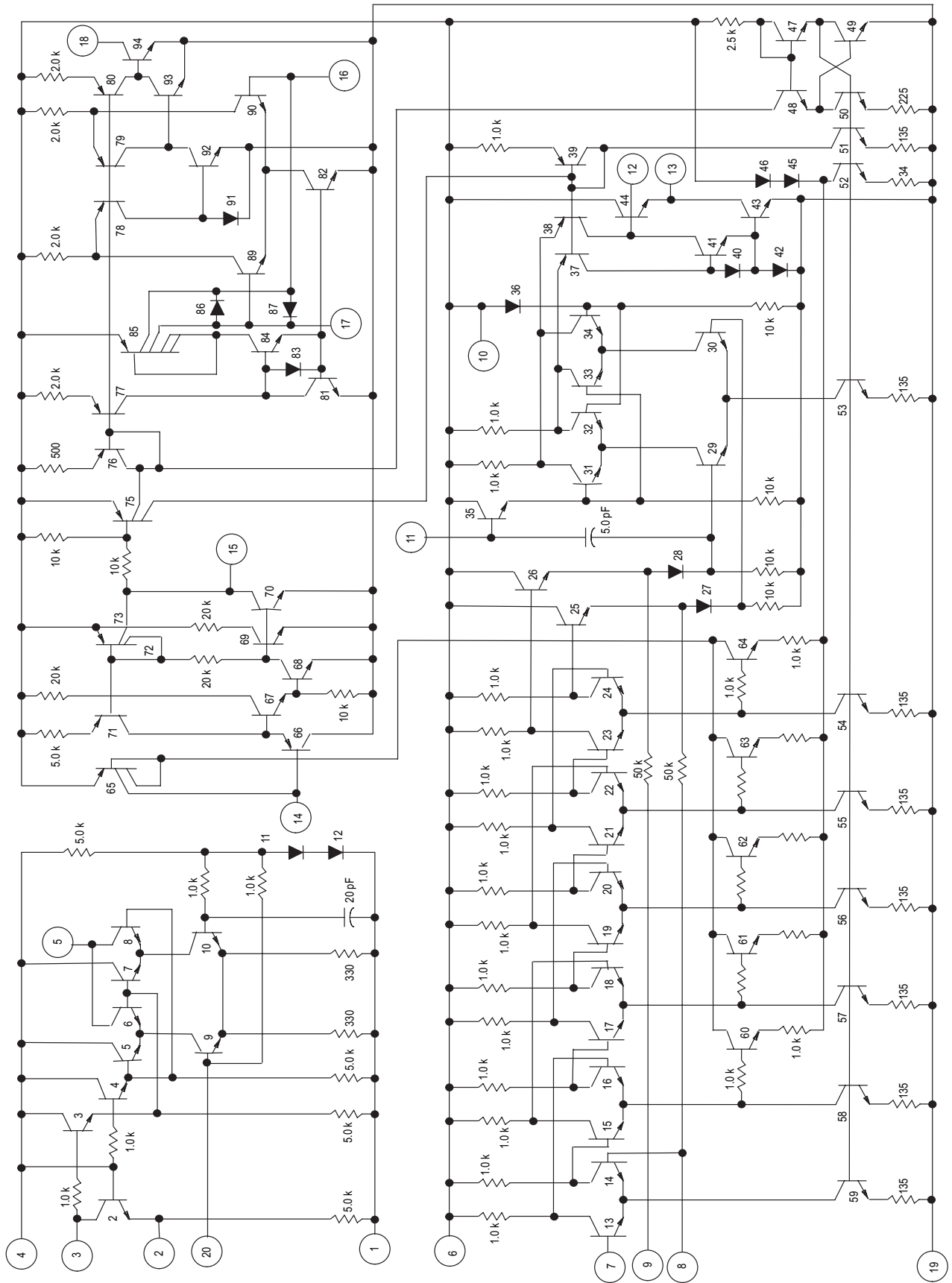

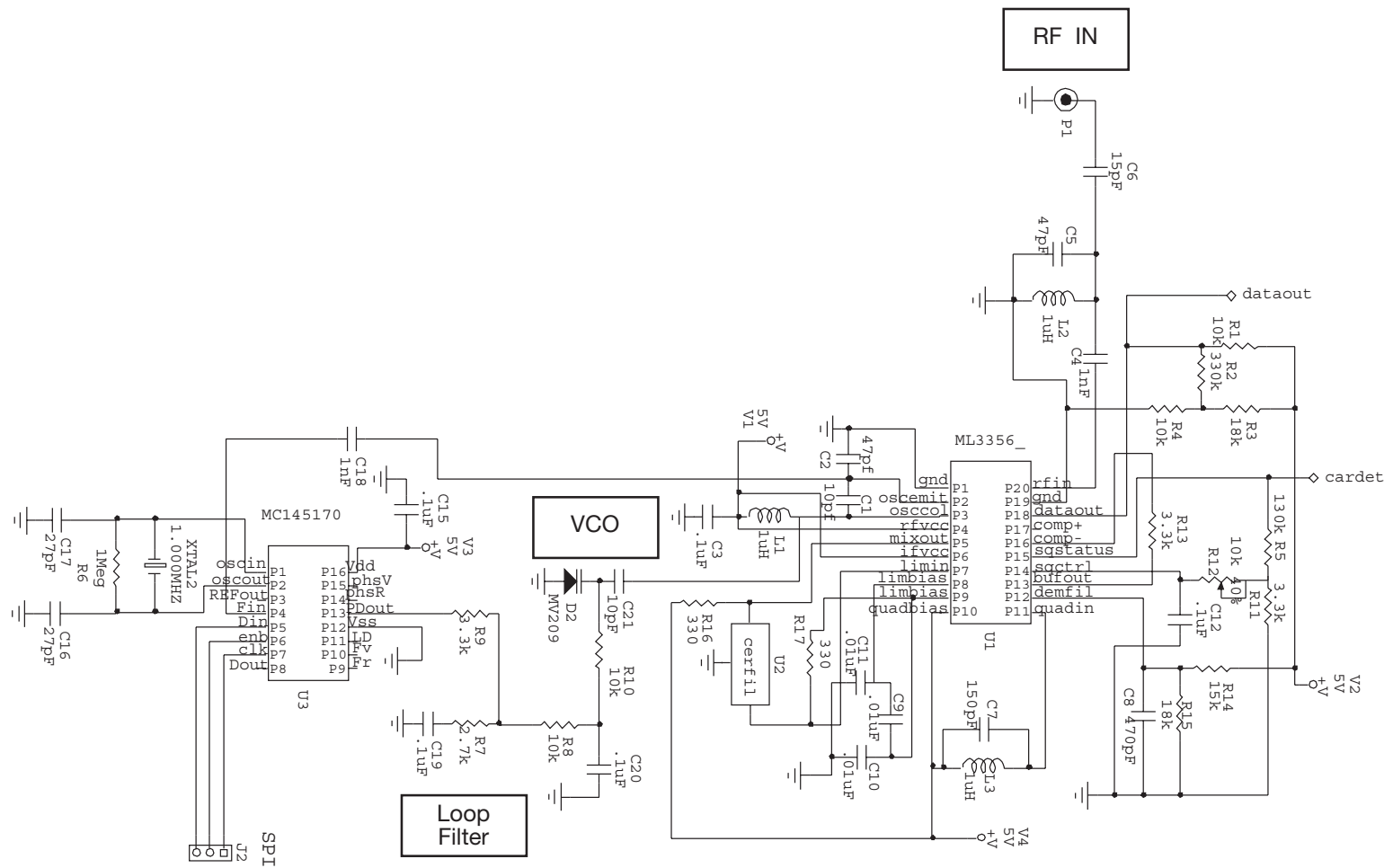

Figure 8
Typical Application using a PLL with L.O. less than 185 MHz.

Figure 8 shows a typical application using the MC145170/ML145170 PLL device. The PLL allows the L.O. to be used as a VCO thus allowing multi - channel operation.

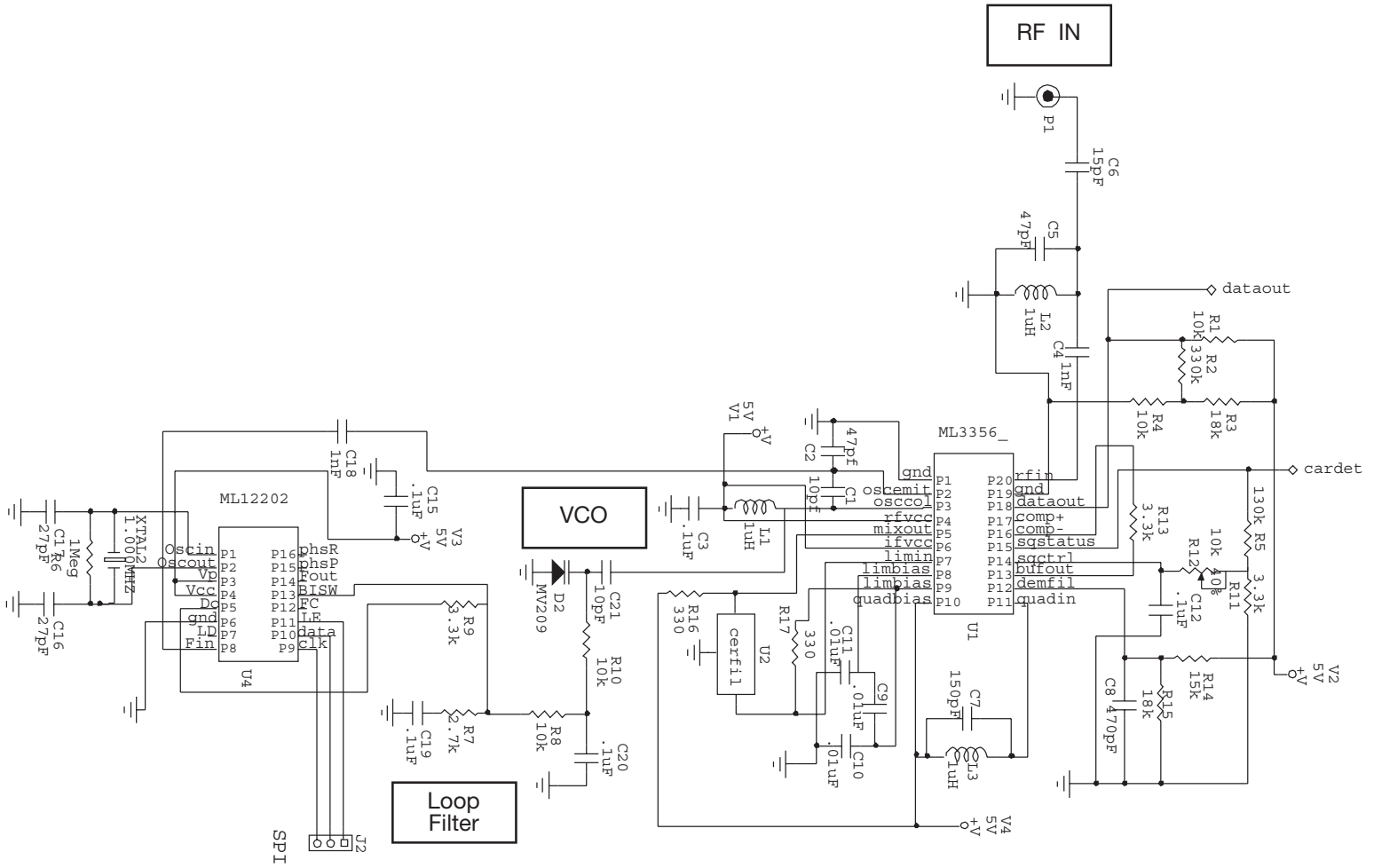
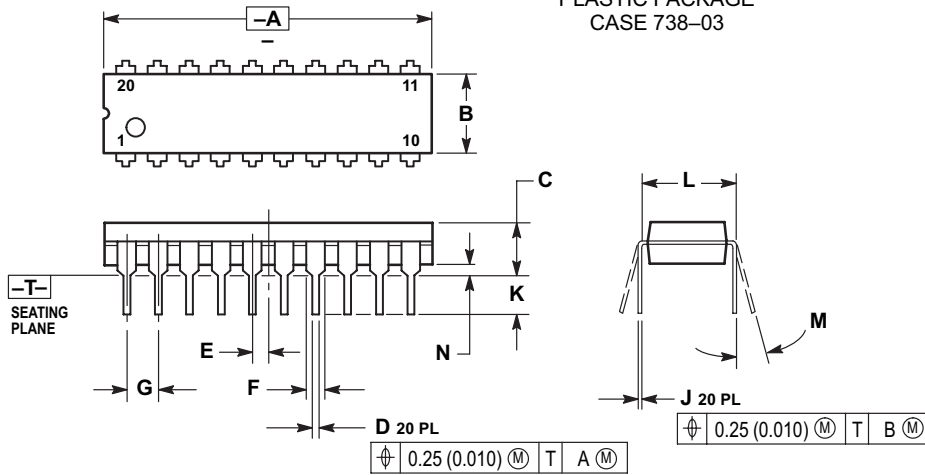

Figure 9
 Typical Application using a PLL with L.O. greater than 185 MHz.

Figure 9 shows a typical application using the ML12202 PLL device. The PLL (ML12202) allows the L.O. to be used as a VCO thus allowing multi-channel operation.

OUTLINE DIMENSIONS

P DIP 20 = RP
 (ML3356RP)
 PLASTIC PACKAGE
 CASE 738-03



- NOTES:
1. DIMENSIONING AND TOLERANCING PER ANSI Y14.5M, 1982.
 2. CONTROLLING DIMENSION: INCH.
 3. DIMENSION "L" TO CENTER OF LEAD WHEN FORMED PARALLEL.
 4. DIMENSION "B" DOES NOT INCLUDE MOLD FLASH.
 5. 738-02 OBSOLETE, NEW STANDARD 738-03.

DIM	MILLIMETERS		INCHES	
	MIN	MAX	MIN	MAX
A	25.66	27.17	1.010	1.070
B	6.10	6.60	0.240	0.260
C	3.81	4.57	0.150	0.180
D	0.39	0.55	0.015	0.022
E	1.27 BSC		0.050 BSC	
F	1.27	1.77	0.050	0.070
G	2.54 BSC		0.100 BSC	
J	0.21	0.38	0.008	0.015
K	2.80	3.55	0.110	0.140
L	7.62 BSC		0.300 BSC	
M	0°	15°	0°	15°
N	0.51	1.01	0.020	0.040

SO 20 = -6P
 (ML3356-6P)
 PLASTIC PACKAGE
 CASE 751D-03
 (SO-20L)

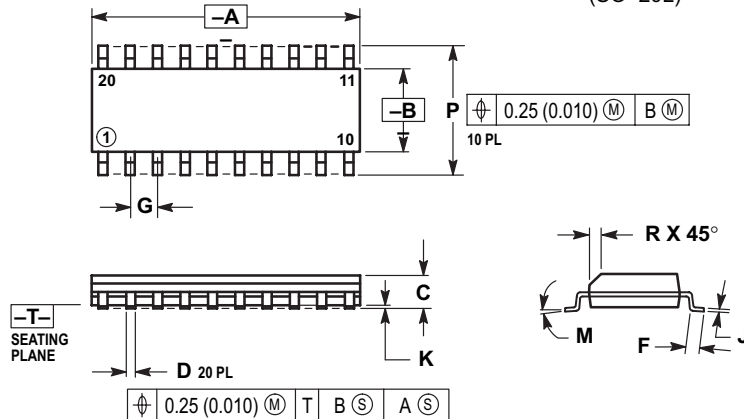

- NOTES:
1. DIMENSIONING AND TOLERANCING PER ANSI Y14.5M, 1982.
 2. CONTROLLING DIMENSION: MILLIMETER.
 3. DIMENSION A AND B DO NOT INCLUDE MOLD PROTRUSION.
 4. MAXIMUM MOLD PROTRUSION 0.15 (0.006) PER SIDE.
 5. 751D-01, AND -02 OBSOLETE, NEW STANDARD 751D-03.

DIM	MILLIMETERS		INCHES	
	MIN	MAX	MIN	MAX
A	12.65	12.95	0.499	0.510
B	7.40	7.60	0.292	0.299
C	2.35	2.65	0.093	0.104
D	0.35	0.49	0.014	0.019
F	0.50	0.90	0.020	0.035
G	1.27 BSC		0.050 BSC	
J	0.25	0.32	0.010	0.012
K	0.10	0.25	0.004	0.009
M	0°	7°	0°	7°
P	10.05	10.55	0.395	0.415
R	0.25	0.75	0.010	0.029

Lansdale Semiconductor reserves the right to make changes without further notice to any products herein to improve reliability, function or design. Lansdale does not assume any liability arising out of the application or use of any product or circuit described herein; neither does it convey any license under its patent rights nor the rights of others. "Typical" parameters which may be provided in Lansdale data sheets and/or specifications can vary in different applications, and actual performance may vary over time. All operating parameters, including "Typicals" must be validated for each customer application by the customer's technical experts. Lansdale Semiconductor is a registered trademark of Lansdale Semiconductor, Inc.