

VIDEO SUPER IMPOSER

■ GENERAL DESCRIPTION

The NJM2207 is video signal superimposer, with synchronous separation circuit, vertical synchronous reproduce circuit and two video high performance switches for switching from video signal to character signal and background signal.

The NJM2207 is suitable for simply indicating the date time, TV channel and others.

■ FEATURES

- Operating Voltage (+4.75V~+13V)
- With Synchronous Separation Circuit
- With Vertical Synchronous Reproduce Circuit.
- Package Outline DIP-14, DMP-14, ZIP-16
- Bipolar Technology

■ RECOMMENDED OPERATING CONDITION

- Operating Voltage 4.75~13V

■ PACKAGE OUTLINE

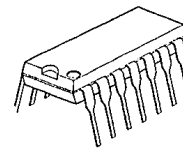

NJM2207D

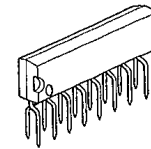

NJM2207S

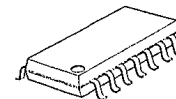

NJM2207M

■ ABSOLUTE MAXIMUM RATINGS

(Ta=25°C)

PARAMETER	SYMBOL	RATINGS	UNIT
Supply Voltage	V*	17	V
Power Dissipation	Pd	(ZIP16) 500	mW
		(DIP14) 700	mW
		(DMP14) 300	mW
Operating Temperature Range	Topr	-40~+85	°C
Storage Temperature Range	Tstg	-40~+125	°C

■ ELECTRICAL CHARACTERISTICS

(Ta=25°C, V*=5V)

PARAMETER	SYMBOL	TEST CONDITION	MIN.	TYP.	MAX.	UNIT
Operating Current	Icc		—	6.5	9	mA

Video Signal Processing Section (Video Input 2Vpp, Source Resistance=75Ω)

PARAMETER	SYMBOL	TEST CONDITION	MIN.	TYP.	MAX.	UNIT
OFF-SET Voltage (Back-ground Input)	V _{BOS}	Cross Voltage In Ext. 10kΩ Resistor	—	—	0.1	V
OFF-SET Voltage (Char. Input)	V _{COS}	Cross Voltage In Ext. 10kΩ Resistor.	—	—	0.1	V
OFF-Voltage (Background Cont. Input)	V _{BL}		—	—	0.4	V
OFF-Voltage (Char. Cont Input)	V _{CL}		—	—	0.4	V
ON-Voltage (Background Cont. Input)	V _{BH}		2.0	—	—	V
ON-Voltage (Char. Cont. Input)	V _{CH}		2.0	—	—	V
Transfer Gain	G _V	R _L =5kΩ	-1	—	+1	dB
Frequency Response	G _f	f=10MHz, R _L =5kΩ	—	-0.2	—	dB
Crosstalk In Each Signal	C _T	Video Input (f=3.58MHz)	—	50	—	
		Background Input (f=3.48MHz)				
		Char. Input (f=3.68MHz)				
		Each Signal. is Sine-Wave R _L =5kΩ				
Video Differential Phase	DP	R _L =5kΩ	—	—	3	Deg
Video Differential Gain	DG	R _L =5kΩ	—	—	3	%



■ ELECTRICAL CHARACTERISTICS SYNC. SEPARATION SECTION

($T_a=25^\circ\text{C}$, $V^+=5\text{V}$)

PARAMETER	SYMBOL	TEST CONDITION	MIN.	TYP.	MAX.	UNIT
*Sync. Sepa. Input Threshold Voltage	V_{ISP}	Source Resistance $R_g=75\Omega$	100	140	180	mV
H-Sync. High Level	V_{IH11}	$R_L=100\text{k}\Omega$ Pin 3 (13)	4.0	—	—	V
H-Sync. High Level	V_{IH12}	$R_L=2.2\text{k}\Omega$ Pin 3 (13)	3.6	4.1	—	V
H-Sync. Low Level	V_{HLL}	$R_L=2.2\text{k}\Omega$ Pin 3 (13)	—	—	0.1	V
H-Sync. High Level	V_{IH11}	$R_L=100\text{k}\Omega$ Pin 4 (14)	4.9	—	—	V
H-Sync. Low Level	V_{HLL}	$R_L=100\text{k}\Omega$ Pin 4 (14)	—	—	0.3	V
V-Sync. High Level	V_{VIH}	$R_L=100\text{k}\Omega$ Pin 7 (2)	4.0	—	—	V
V-Sync. High Level	V_{VH2}	$R_L=10\text{k}\Omega$ Pin 7 (2)	3.6	4.1	—	V
V-Sync. Low Level	V_{VLL}	$R_L=10\text{k}\Omega$ Pin 7 (2)	—	—	0.1	V
V-Sync. High Level	V_{VH1}	$R_L=100\text{k}\Omega$ Pin 9 (4)	4.9	—	—	V
V-Sync. Low Level	V_{VLL}	$R_L=100\text{k}\Omega$ Pin 9 (4)	—	—	0.3	V
Schmitt Trigger						
Threshold High Level	V_{VTH}	Pin 5 Input Voltage (1)	1.9	2.1	2.3	V
Threshold Low Level	V_{VTL}	Pin 5 Input Voltage (1)	1.1	1.3	1.5	V

(Note) : () to DIP-14/DMP-14

* A version (100mV Typ.)

■ TEST CIRCUIT

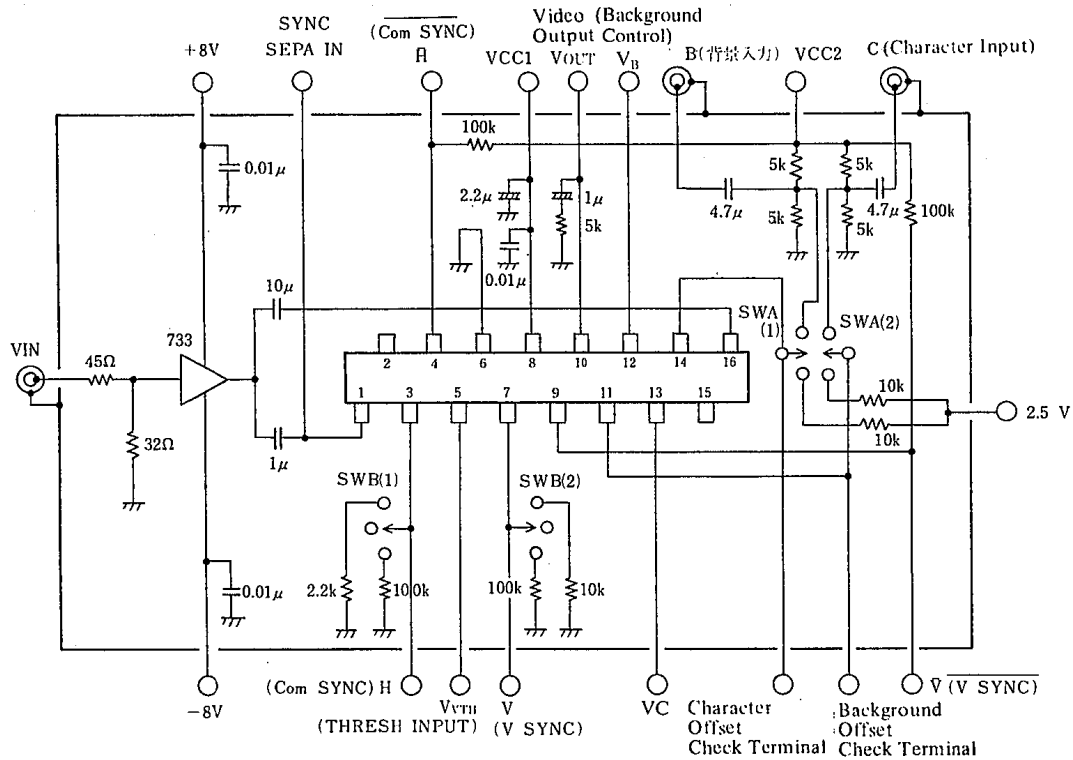

5

■ TYPICAL APPLICATION

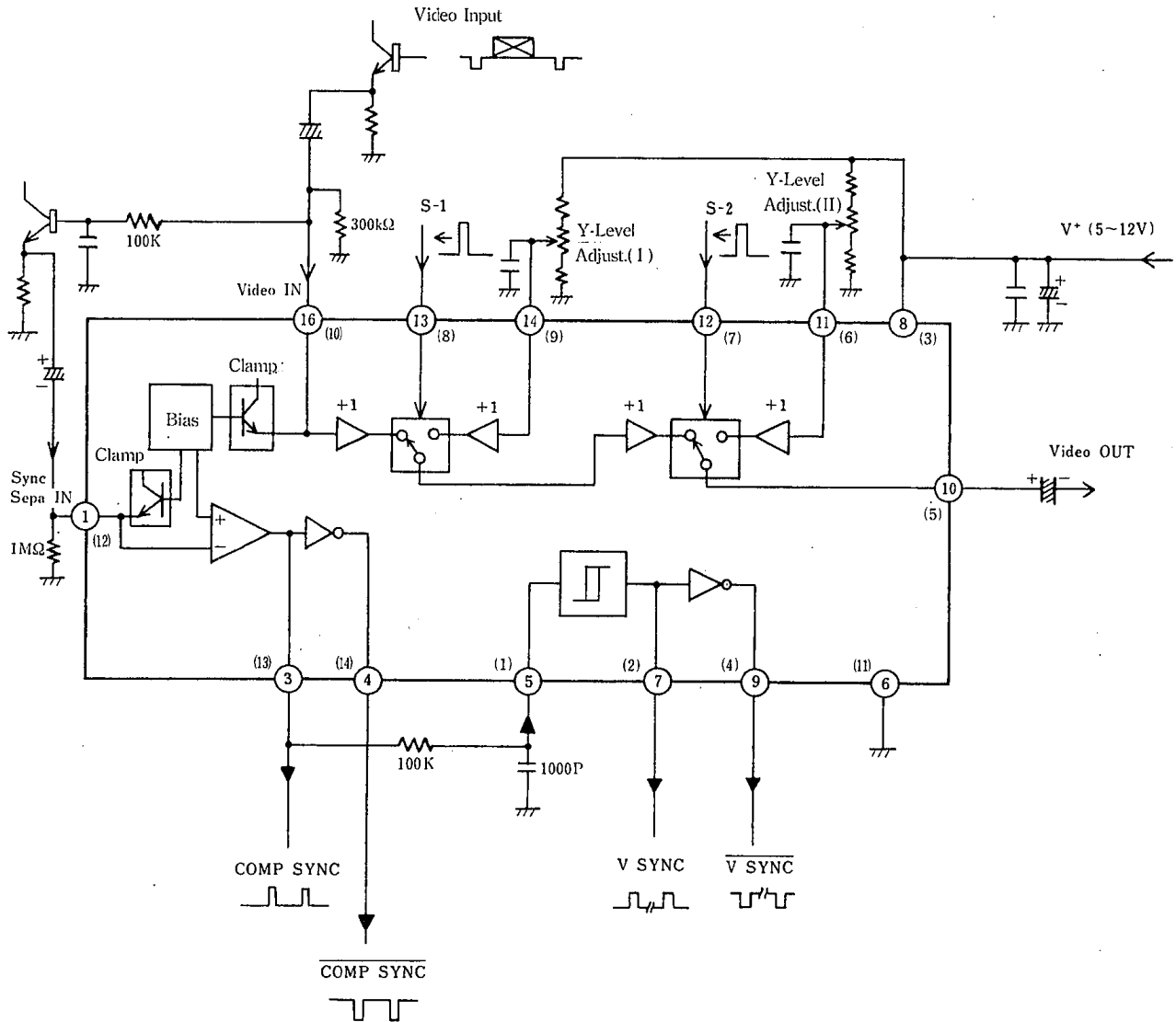

Note 1: Pin Connection to ZIP-16 (Pin 2, Pin 15: NC). () to DIP-14/DMP-14

Note 2: Syn. Sepa. Input Threshold voltage increases 40mV (typ.) when putting 1MΩ in to Pin 1 (Pin 12).

5

■ PRINCIPLE OF CHARACTER SUPERIMOSER

Basic principle is shown at Fig. 1.

Usual TV has video (composite) signal output and input terminals to connect VCR or others. There is all information about picture on video composite signal (Ref. to Fig. 2). Its time signal of horizontal and vertical synchronous signal indicates the brighten place of TV tube. For brightening TV tube regardless video signal, the video input signal has to be switched to DC level (luminance level) on that scanning time. On this method, character is shown with background of usual picture.

Fig.1 Principle of Character Superimposer

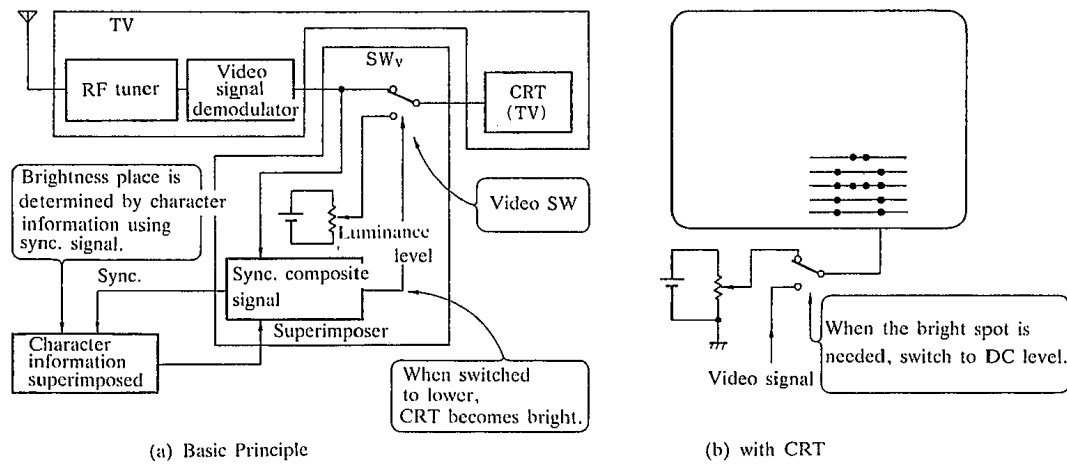

5

Fig.2 Composite Video Signal

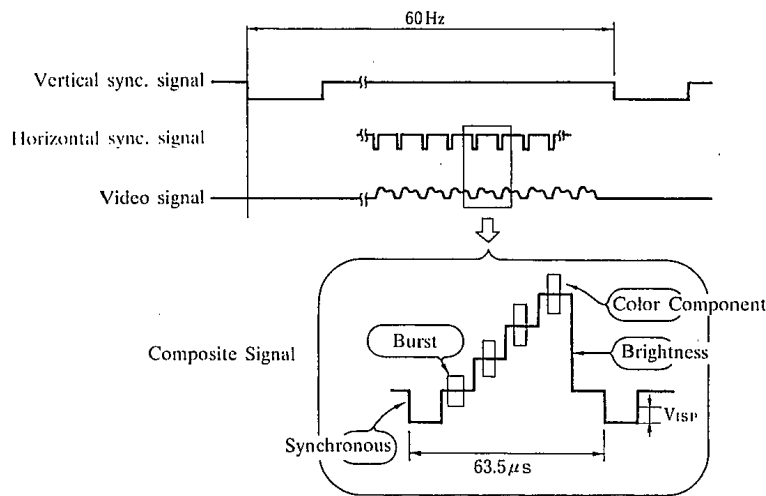

■ CIRCUIT CONFIGURATION

Date superimposer circuit configuration on TV is shown at Fig. 3. The NJM2207 includes video switches which convert, usual video signal (horizontal and vertical synchronous signal, video) to signal, of superimposed character given by character generator.

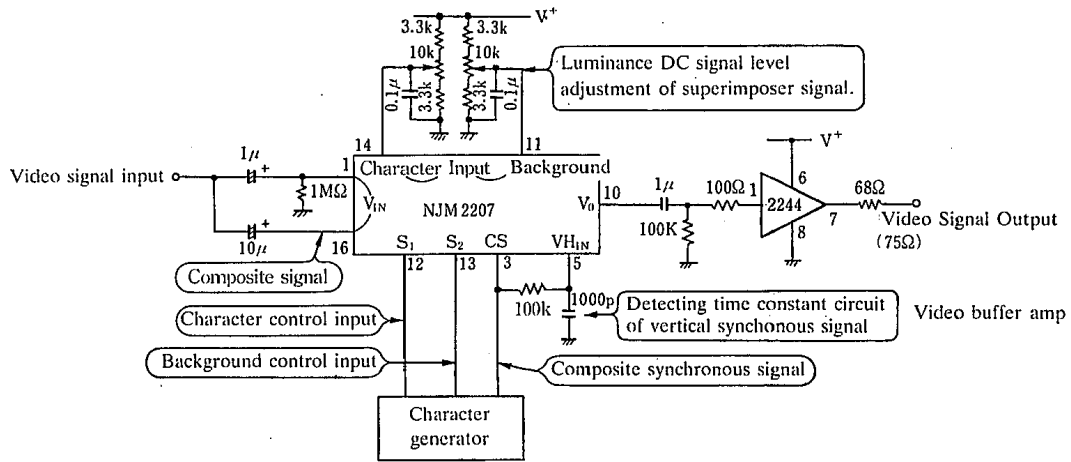

Fig.3 Typical circuit of date superimposer

MEMO

[CAUTION]

The specifications on this databook are only given for information, without any guarantee as regards either mistakes or omissions. The application circuits in this databook are described only to show representative usages of the product and not intended for the guarantee or permission of any right including the industrial rights.