

PC922

High Power OPIC Photocoupler

※ Lead forming type (I type) and taping reel type (P type) are also available. (PC922I/PC922P)

※※ TÜV (VDE 0884) approved type is also available as an option.

■ Features

1. Built-in base amplifier for inverter drive
2. High power (I_{O1} : MAX. 0.5A (DC))
(I_{O2P} : MAX. 2.0A (pulse))
3. High isolation voltage between input and output (V_{iso} : 5 000V_{rms})
4. High noise reduction type
5. High speed response (t_{PHL} , t_{PLH} : MAX. 5 μ s)
6. High sensitivity (I_{FLH} : MAX. 3mA)
7. Recognized by UL, file No. E64380

■ Applications

1. Inverter controlled air conditioners
2. Small capacitance general purpose inverters

■ Outline Dimensions

(Unit : mm)

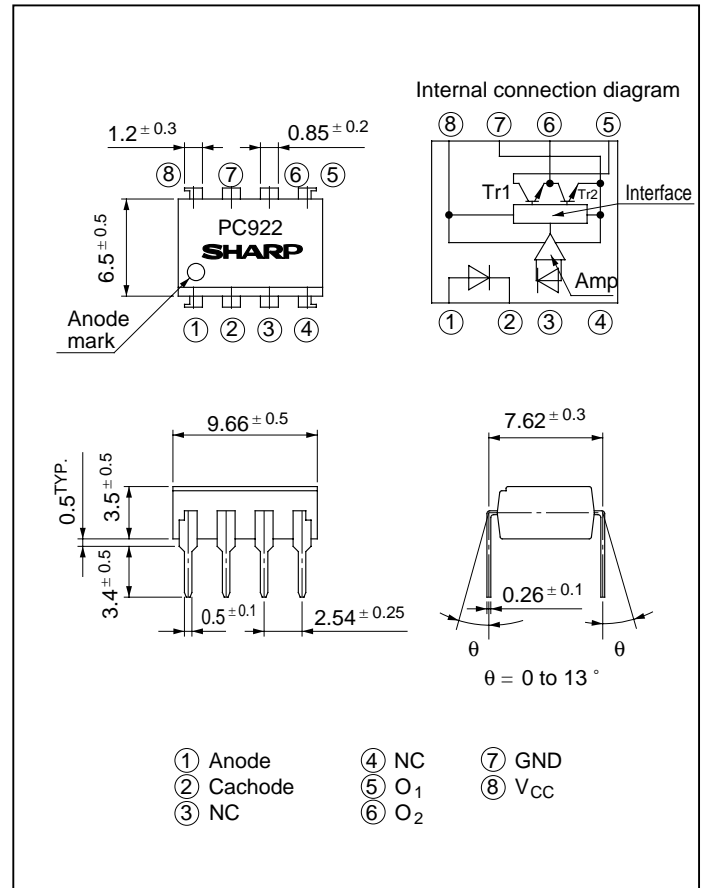

* " OPIC " (Optical IC) is a trademark of the SHARP Corporation.
 An OPIC consists of a light-detecting element and signal-processing circuit integrated onto a single chip.

■ Absolute Maximum Ratings

($T_a = T_{opr}$ unless otherwise specified)

| | Parameter | Symbol | Rating | Unit |
|--------|---------------------------------------|-----------|---------------|------------------|
| Input | Forward current | I_F | 25 | mA |
| | *1 Reverse voltage | V_R | 6 | V |
| Output | Supply voltage | V_{CC} | 18 | V |
| | O ₁ output current | I_{O1} | 0.5 | A |
| | *2 O ₁ peak output current | I_{O1P} | 1.0 | A |
| | O ₂ output current | I_{O2} | 0.6 | A |
| | *2 O ₂ peak output current | I_{O2P} | 2.0 | A |
| | O ₁ output voltage | V_{O1} | 18 | V |
| | Power dissipation | P_O | 500 | mW |
| | Total power dissipation | P_{tot} | 550 | mW |
| | *3 Isolation voltage | V_{iso} | 5 000 | V _{rms} |
| | Operating temperature | T_{opr} | - 20 to + 80 | °C |
| | Storage temperature | T_{stg} | - 55 to + 125 | °C |
| | *4 Soldering temperature | T_{sol} | 260 | °C |

*1 $T_a = 25^\circ\text{C}$

*2 Pulse width $\leq 5\mu\text{s}$, Duty ratio: 0.01

*3 40 to 60% RH, AC for 1 minute,
 $T_a = 25^\circ\text{C}$

*4 For 10 seconds

■ Electro-optical Characteristics

($T_a = T_{opr}$ unless otherwise specified)

| Parameter | | Symbol | Conditions | MIN. | TYP. | MAX. | Unit | Fig. | |
|--|---|--|--|---|-----------|------------------------|------------------------|---------------|---|
| Input | Forward voltage | V_{F1} | $T_a = 25^\circ\text{C}, I_F = 5\text{mA}$ | - | 1.1 | 1.4 | V | - | |
| | | V_{F2} | $T_a = 25^\circ\text{C}, I_F = 0.2\text{mA}$ | 0.6 | 0.9 | - | V | - | |
| | Reverse current | I_R | $T_a = 25^\circ\text{C}, V_R = 3\text{V}$ | - | - | 10 | μA | - | |
| | Terminal capacitance | C_t | $T_a = 25^\circ\text{C}, V = 0, f = 1\text{kHz}$ | - | 30 | 250 | pF | - | |
| Output | Operating supply voltage | V_{CC} | | 5.4 | - | 13 | V | - | |
| | O ₁ low level output voltage | V_{O1L} | $V_{CC} = 6\text{V}, I_{O1} = 0.4\text{A}, R_{L2} = 10\Omega, I_F = 5\text{mA}$ | - | 0.2 | 0.4 | V | 1 | |
| | O ₂ high level output voltage | V_{O2H} | $V_{CC} = 6\text{V}, I_{O2} = -0.4\text{A}, I_F = 5\text{mA}$ | 4.5 | 5.0 | - | V | 2 | |
| | O ₂ low level output voltage | V_{O2L} | $V_{CC} = 6\text{V}, I_{O2} = 0.5\text{A}, I_F = 0$ | - | 0.2 | 0.4 | V | - | |
| | O ₁ leak current | I_{O1L} | $V_{CC} = 13\text{V}, I_F = 0$ | - | - | 200 | μA | 3 | |
| | O ₂ leak current | I_{O2L} | $V_{CC} = 13\text{V}, I_F = 5\text{mA}$ | - | - | 200 | μA | 4 | |
| | High level supply current | I_{CCH} | $T_a = 25^\circ\text{C}, V_{CC} = 6\text{V}, I_F = 5\text{mA}$ | - | 9 | 13 | mA | - | |
| | | | $V_{CC} = 6\text{V}, I_F = 5\text{mA}$ | - | - | 17 | mA | - | |
| | Low level supply current | I_{CCL} | $T_a = 25^\circ\text{C}, V_{CC} = 6\text{V}, I_F = 0$ | - | 11 | 15 | mA | - | |
| $V_{CC} = 6\text{V}, I_F = 0$ | | | - | - | 20 | mA | - | | |
| Transfer characteristics | *5 "Low→High" threshold input current | I_{FLH} | $T_a = 25^\circ\text{C}, V_{CC} = 6\text{V}, R_{L1} = 5\Omega, R_{L2} = 10\Omega$ | 0.3 | 1.5 | 3.0 | mA | 5 | |
| | | | $V_{CC} = 6\text{V}, R_{L1} = 5\Omega, R_{L2} = 10\Omega$ | 0.2 | - | 5.0 | mA | 5 | |
| | Isolation resistance | R_{ISO} | $T_a = 25^\circ\text{C}, \text{DC} = 500\text{V}$ 40 to 60% RH | 5×10^{10} | 10^{11} | - | Ω | - | |
| | Response time | | "Low→High" propagation delay time | $T_a = 25^\circ\text{C}, V_{CC} = 6\text{V}$ $I_F = 5\text{mA}, R_{L1} = 5\Omega, R_{L2} = 10\Omega$ | - | 2 | 5 | μs | 6 |
| | | | "High→Low" propagation delay time | | - | 2 | 5 | μs | |
| | | | Rise time | | - | 0.2 | 1 | μs | |
| | | | Fall time | | - | 0.1 | 1 | μs | |
| | Instantaneous common mode rejection voltage "Output : High level" | CM_H | $T_a = 25^\circ\text{C}, V_{CM} = 600\text{V}_{(peak)}$ $I_F = 5\text{mA}, R_{L1} = 470\Omega, R_{L2} = 1\text{k}\Omega,$ $\Delta V_{O2H} = 0.5\text{V}$ | -1 500 | - | - | $\text{V}/\mu\text{s}$ | 7 | |
| Instantaneous common mode rejection voltage "Output : Low level" | CM_L | $T_a = 25^\circ\text{C}, V_{CM} = 600\text{V}_{(peak)}$ $I_F = 0, R_{L1} = 470\Omega, R_{L2} = 1\text{k}\Omega$ $\Delta V_{O2L} = 0.5\text{V}$ | 1 500 | - | - | $\text{V}/\mu\text{s}$ | 7 | | |

*5 I_{FLH} represents forward current when output goes from low to high.

■ Truth Table

| Input | O ₂ Output | Tr. 1 | Tr. 2 |
|-------|-----------------------|-------|-------|
| ON | High level | ON | OFF |
| OFF | Low level | OFF | ON |

■ Test Circuit

Fig. 1

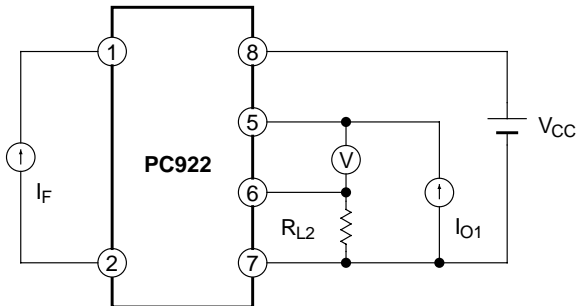

Fig. 2

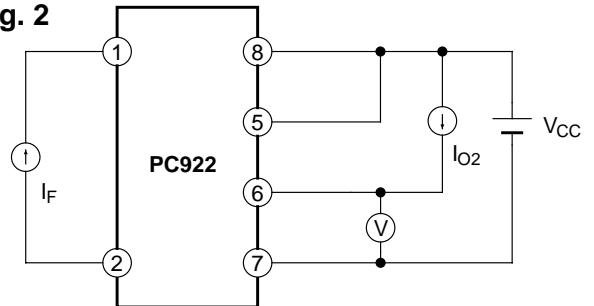

Fig. 3

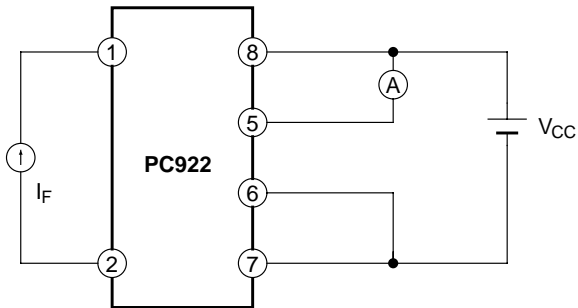

Fig. 4

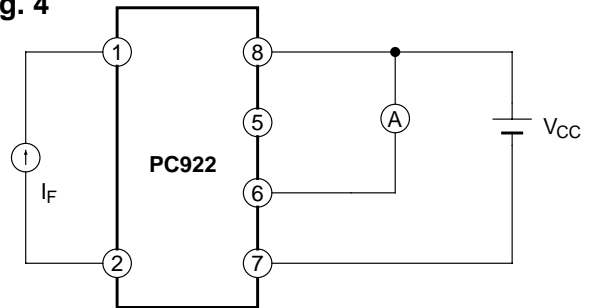

Fig. 5

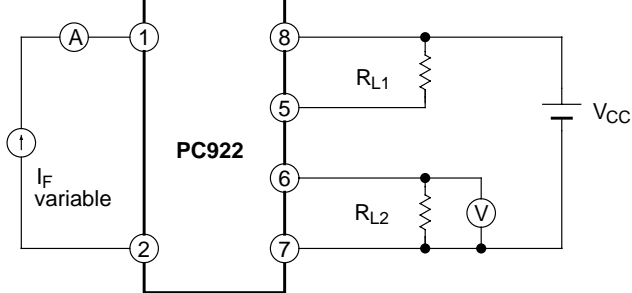

Fig. 6

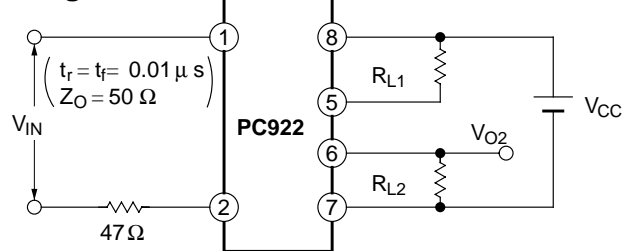

Fig. 7

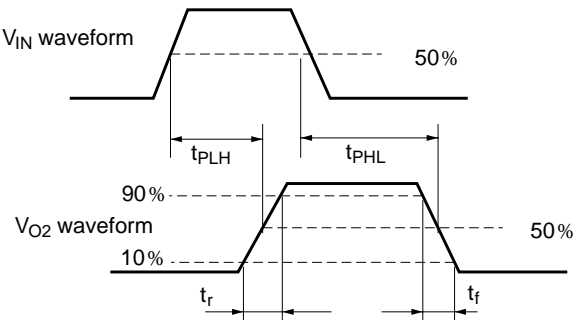
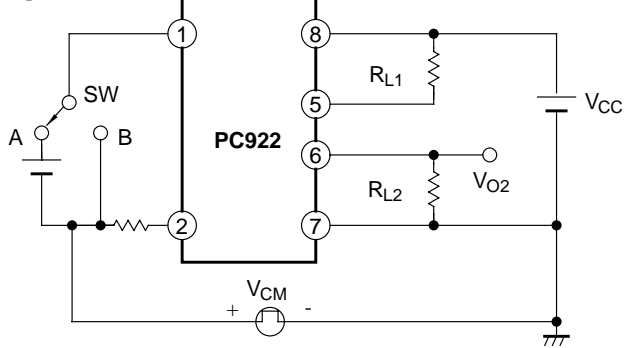

Fig. 8 Forward Current vs. Ambient Temperature

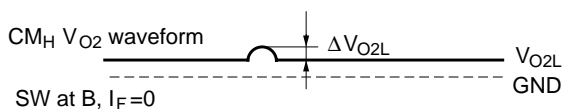
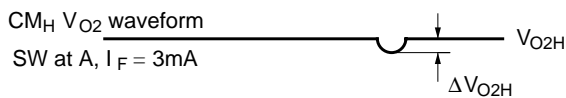
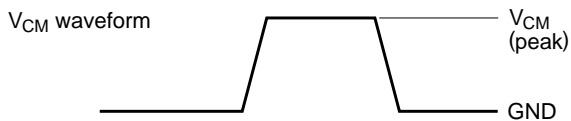
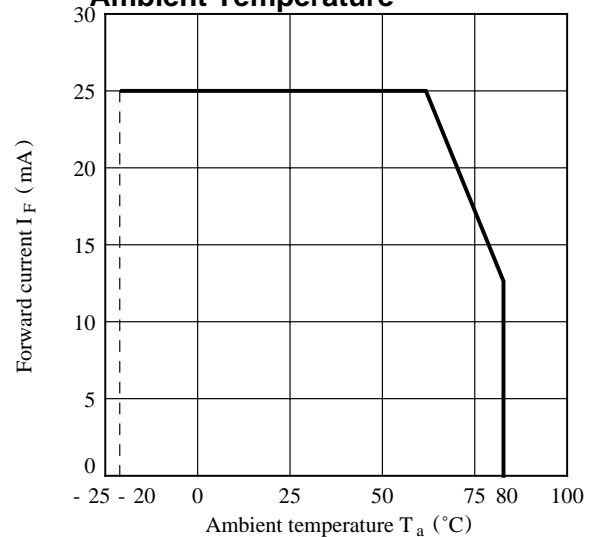

Fig. 9-a Power Dissipation vs. Ambient Temperature

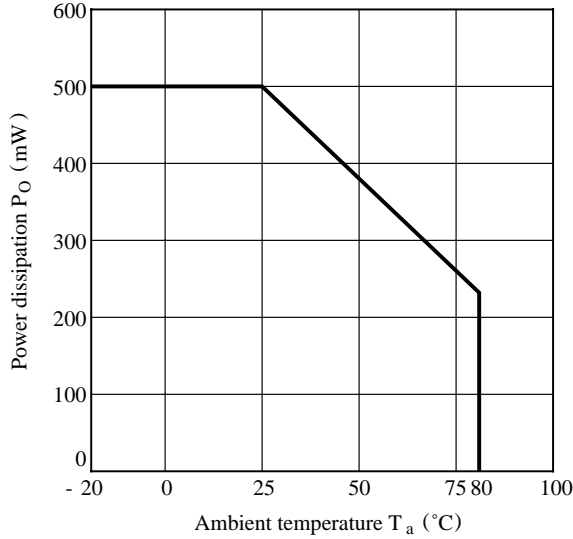

Fig. 9-b Power Dissipation vs. Ambient Temperature

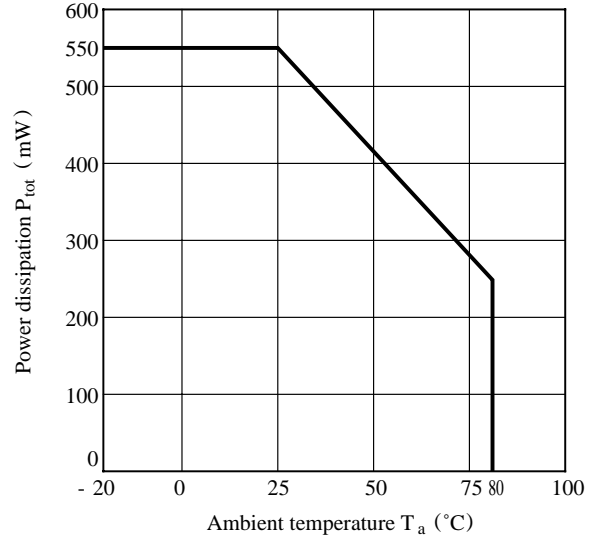

Fig. 10 Forward Current vs. Forward Voltage

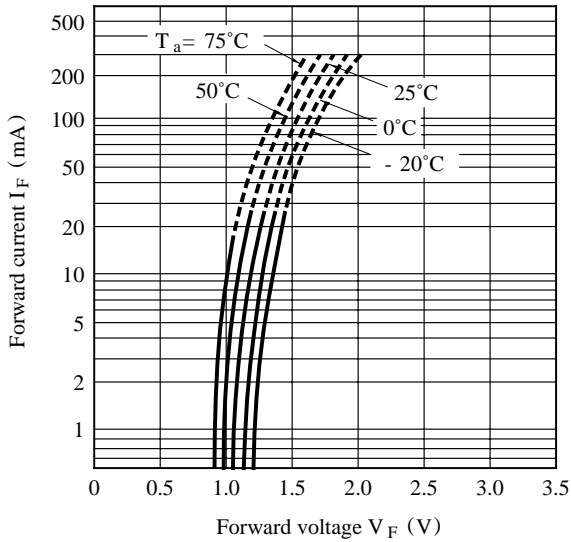

Fig.11 “ Low →High ” Relative Threshold Input Current vs. Supply Voltage

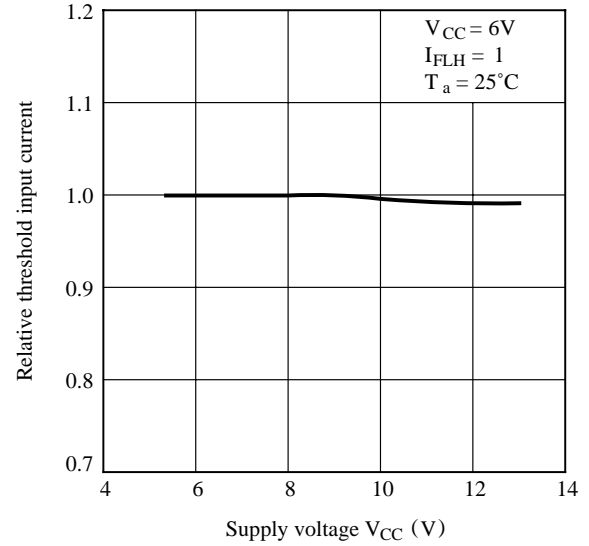

Fig.12 “ Low →High ” Relative Threshold Input Current vs. Ambient Temperature

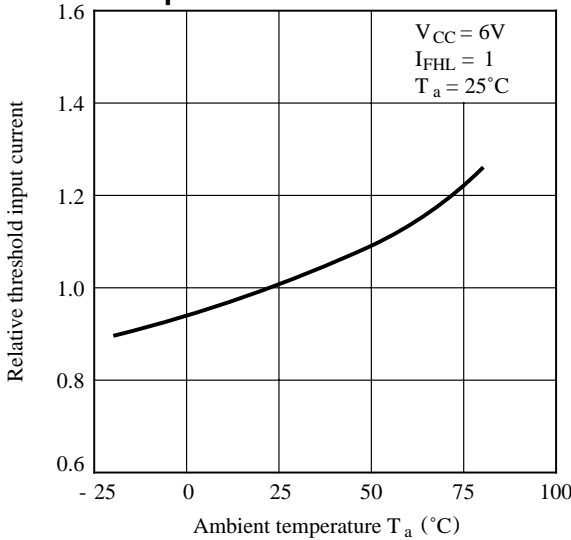

Fig.13 O₁ Low Level Output Voltage vs. O₁ Output Current

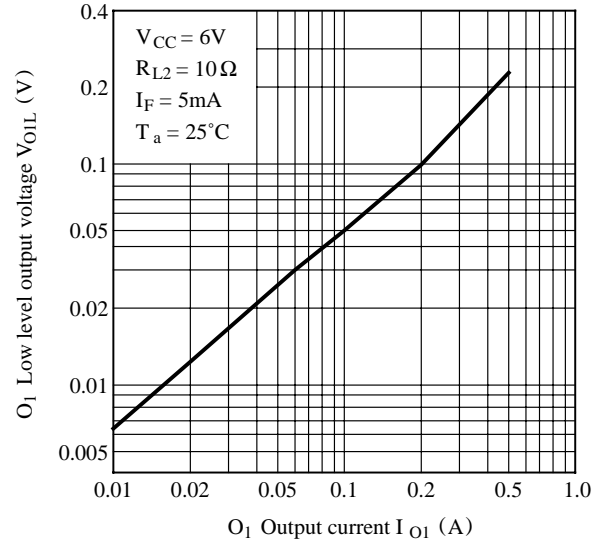

Fig.14 O₁ Low Level Output Voltage vs. Ambient Temperature

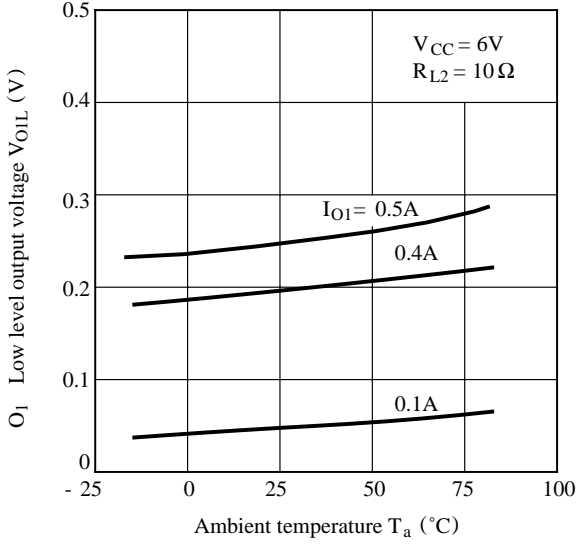

Fig.15 O₂ High Level Output Voltage vs. O₂ Output Current

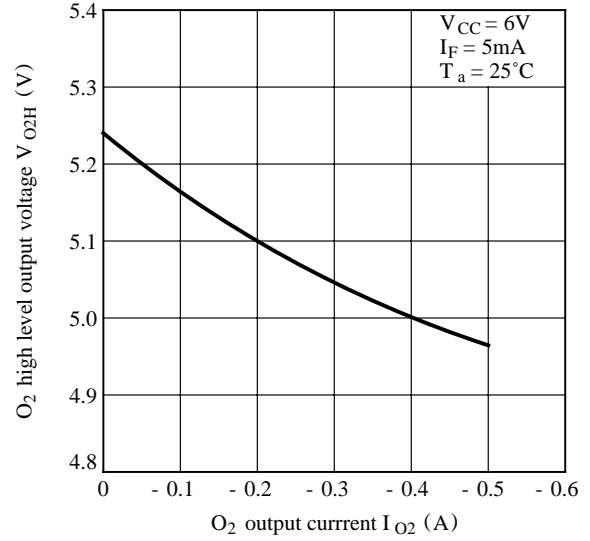

Fig.16 O₂ High Level Output Voltage vs. Ambient Temperature

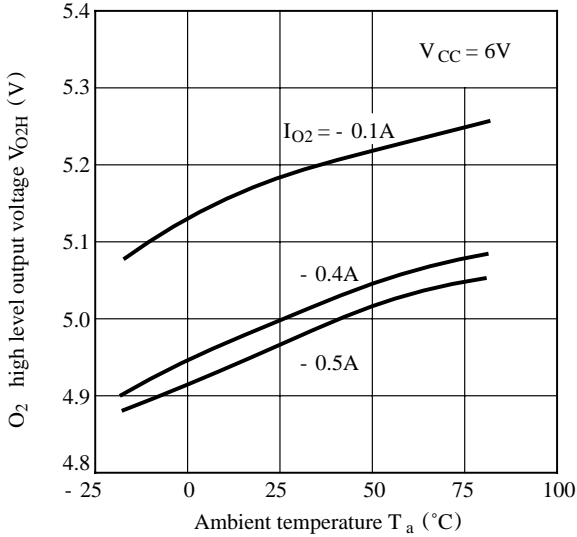

Fig.17 O₂ Low Level Output Voltage vs. O₂ Output Current

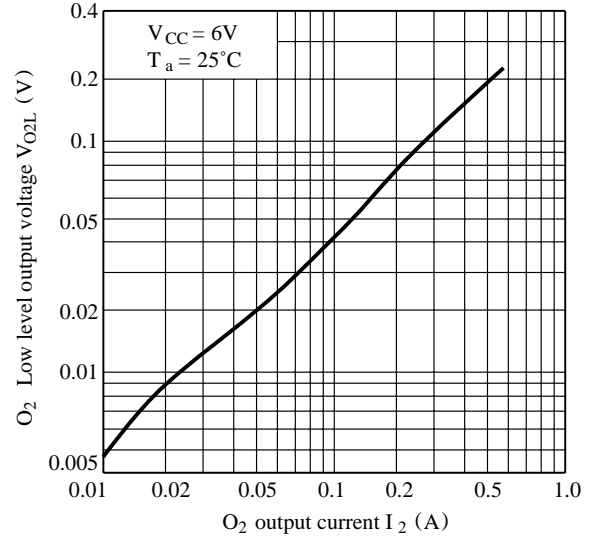

Fig.18 O₂ Low Level Output Voltage vs. Ambient Temperature

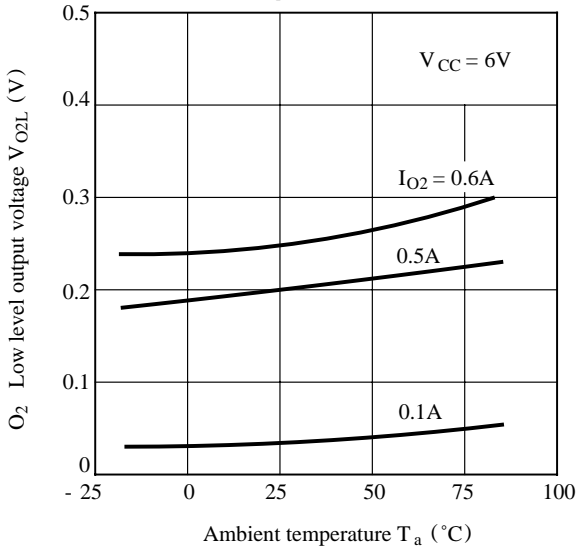

Fig.19 High Level Supply Current vs. Supply Voltage

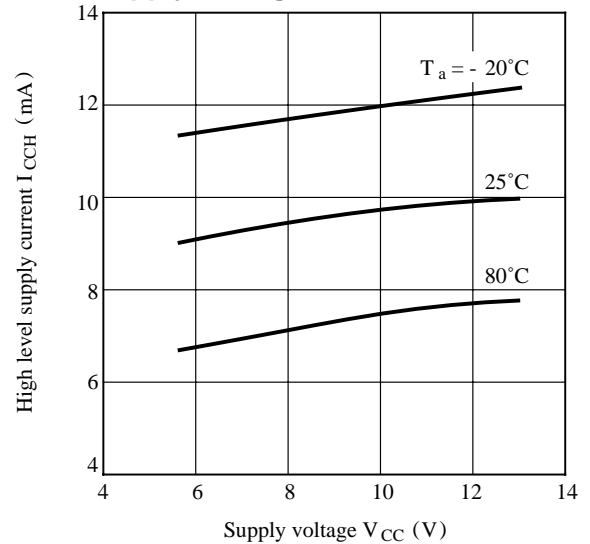

Fig.20 Low Level Supply Current vs. Supply Voltage

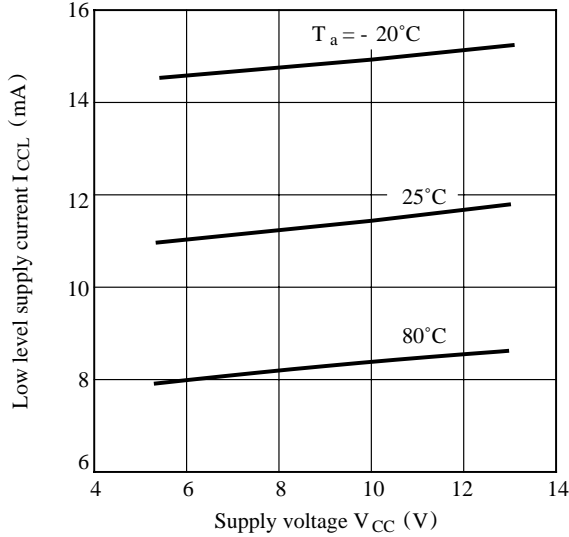

Fig.21 Propagation Delay Time vs. Forward Current

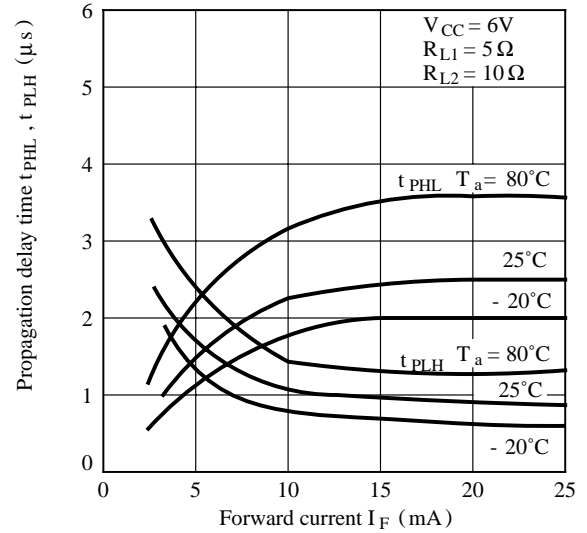

Fig.22 Propagation Delay Time vs. Ambient Temperature

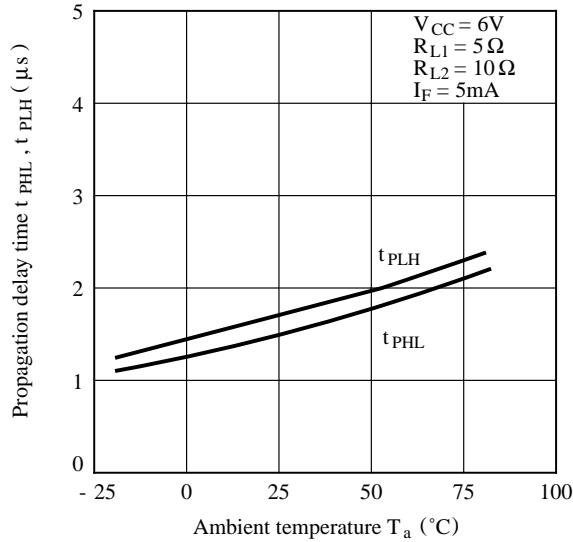
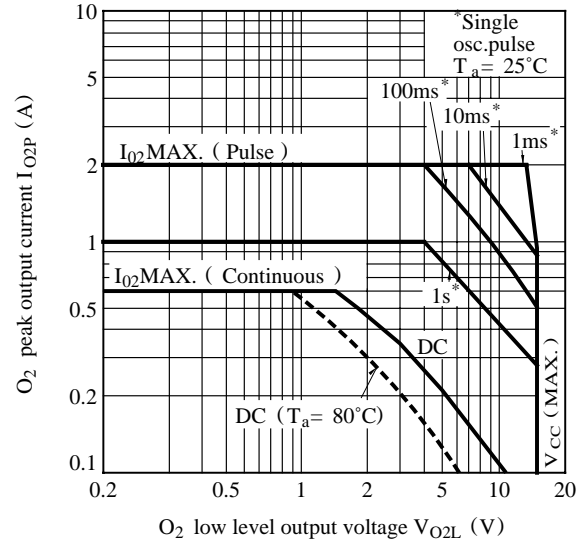
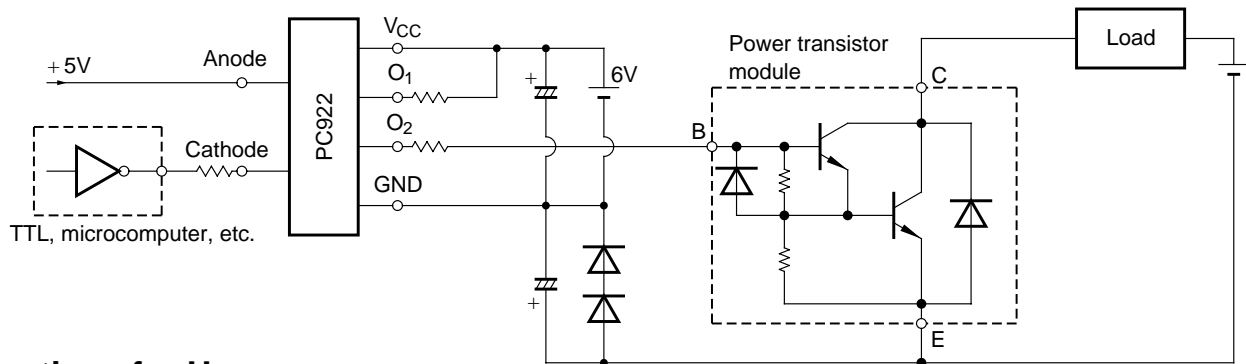

Fig.23 O₂ Peak Output Current vs. O₂ Low Level Output Voltage



Application Circuit



Precautions for Use

- (1) It is recommended that a by-pass capacitor of more than 0.01 μ F is added between V_{CC} and GND near the device in order to stabilize power supply line.
- (2) Handle this product the same as with other integrated circuits against static electricity.
- (3) As for other general cautions, refer to the chapter "Precautions for Use".