

# FAN8039BD3

## 5-CH Motor Driver

### Features

- 1 Phase, Full-wave, Linear DC Motor Driver
- Built-in 5-CH Balanced TransFormerless (BTL) Driver
- Built-in thermal shut down circuit (TSD)
- Built-in Variable Regulator With Power Tr.
- Built-in Power Save Circuit
- Built-in stand by mode circuit
- Wide Operating Supply Voltage : 4.5 ~ 13.2V

### Description

The FAN8039BD3 is a monolithic integrated circuit suitable for a 5-CH motor driver which drives the tracking actuator, focus actuator, sled motor, tray motor, spindle motor of the DVDP/CAR-CD systems.



### Typical Applications

- Compact disk player
- Video compact disk player
- Car compact disk player
- Mixing with compact disk player and mini disk player
- DVDP

### Ordering Information

Device	Package	Operating Temp
FAN8039BD3	28-SSOPH-375SG2	-35°C ~ 85°C
FAN8039BD3TF	28-SSOPH-375SG2	-35°C ~ 85°C

## Pin Assignments

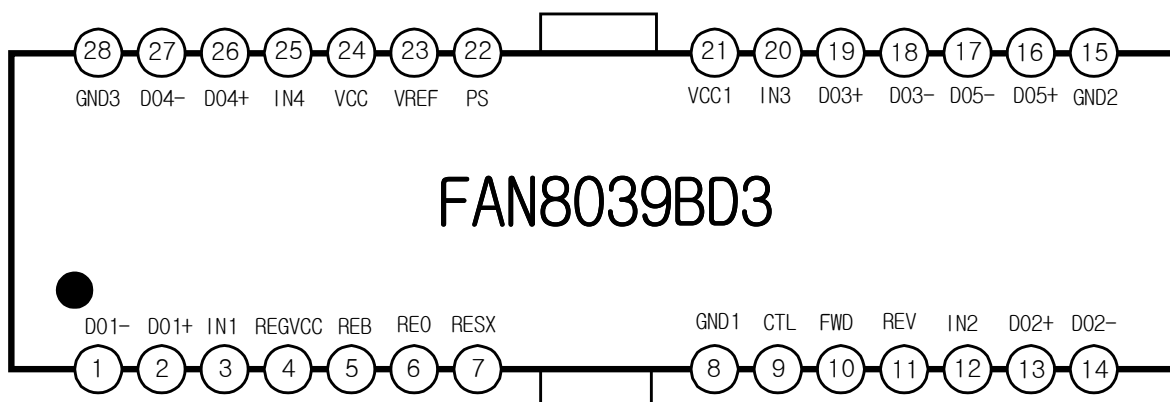

## Pin Definitions

NO	Symbol	Description	NO	Symbol	Description
1	DO1-	CH1 Drive Output (-)	15	GND2	Power Ground1 (CH 2,3,5)
2	DO1+	CH1 Drive Output (+)	16	DO5+	CH5 Drive Output (+)
3	IN1	CH1 Drive Input	17	DO5-	CH5 Drive Output(-)
4	REGVCC	Regulator Supply Voltage	18	DO3-	CH3 Drive Output(-)
5	REB	Regulator Output	19	DO3+	CH3 Drive Output (+)
6	REO	Regulator Feedback Input	20	IN3	CH3 Drive Input
7	RESX	Regulator Reset	21	VCC1	Supply Voltage1(CH2,CH3,CH5)
8	GND1	Signal Ground	22	PS	Power Save
9	CTL	CH5 Motor Speed Control	23	VREF	Bias Voltage
10	FWD	CH5 Forward Input	24	VCC	Supply Voltage(CH1,CH4)
11	REV	CH5 Reverse Input	25	IN4	CH4 Drive Input
12	IN2	CH2 Drive Input	26	DO4+	CH4 Drive Output (+)
13	DO2+	CH2 Drive Output (+)	27	DO4-	CH4 Drive Output (-)
14	DO2-	CH2 Drive Output (-)	28	GND3	Power Ground2 (CH 1,4)

# Internal Block Diagram

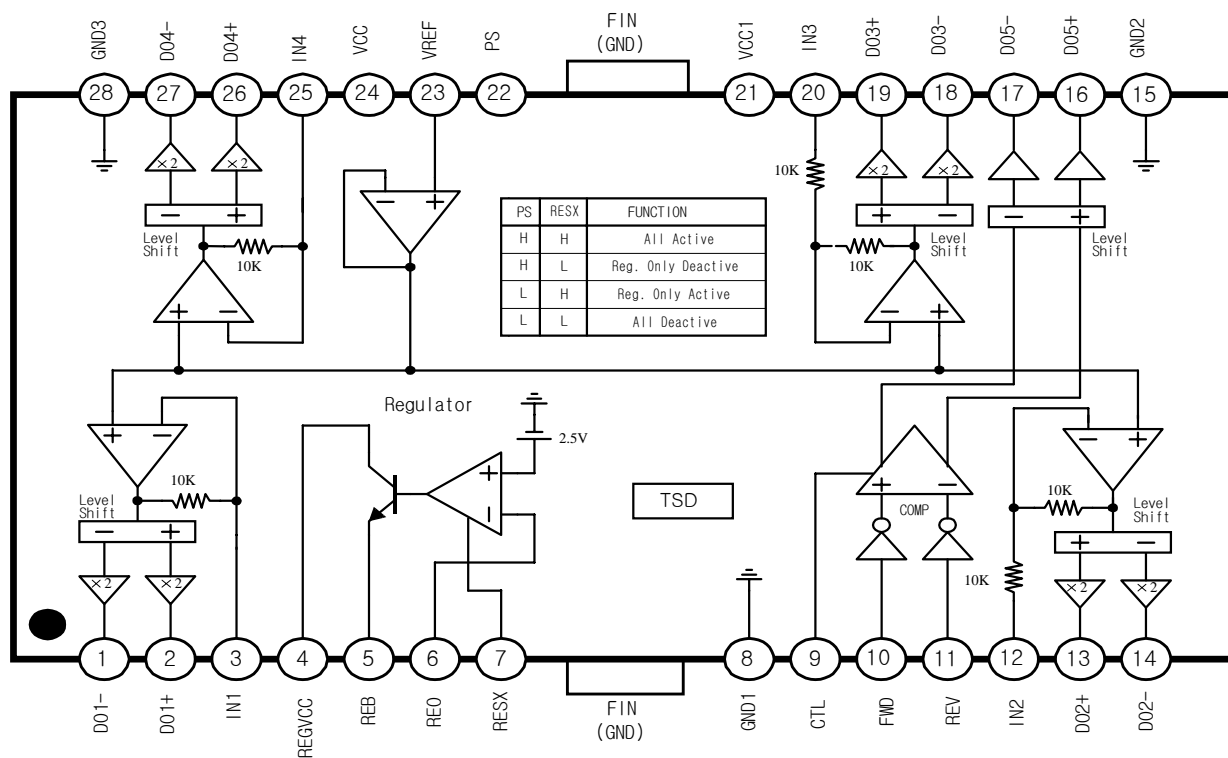

## Equivalent Circuits

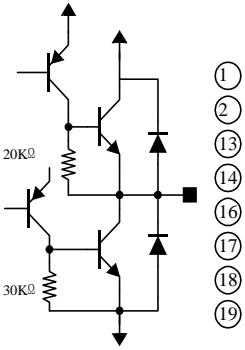
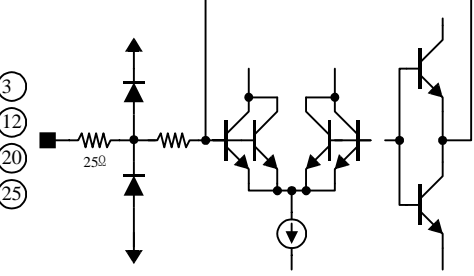
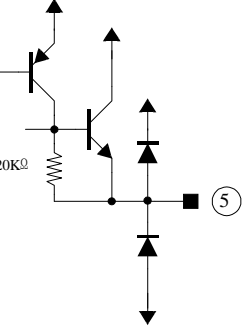
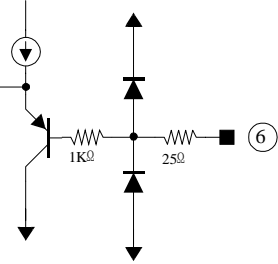
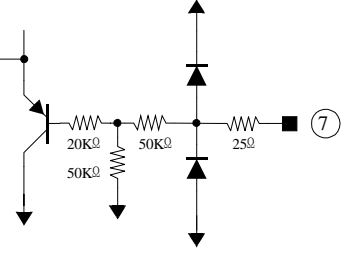
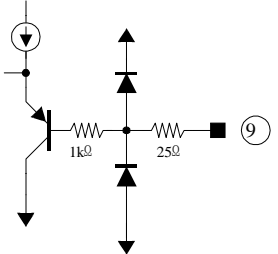
Btl Driver Output	Btl Drive Input
	
Regulator Output	Regulator Feedback Input
	
Regulator Reset	Motor Speed Control
	

## Equivalent Circuits

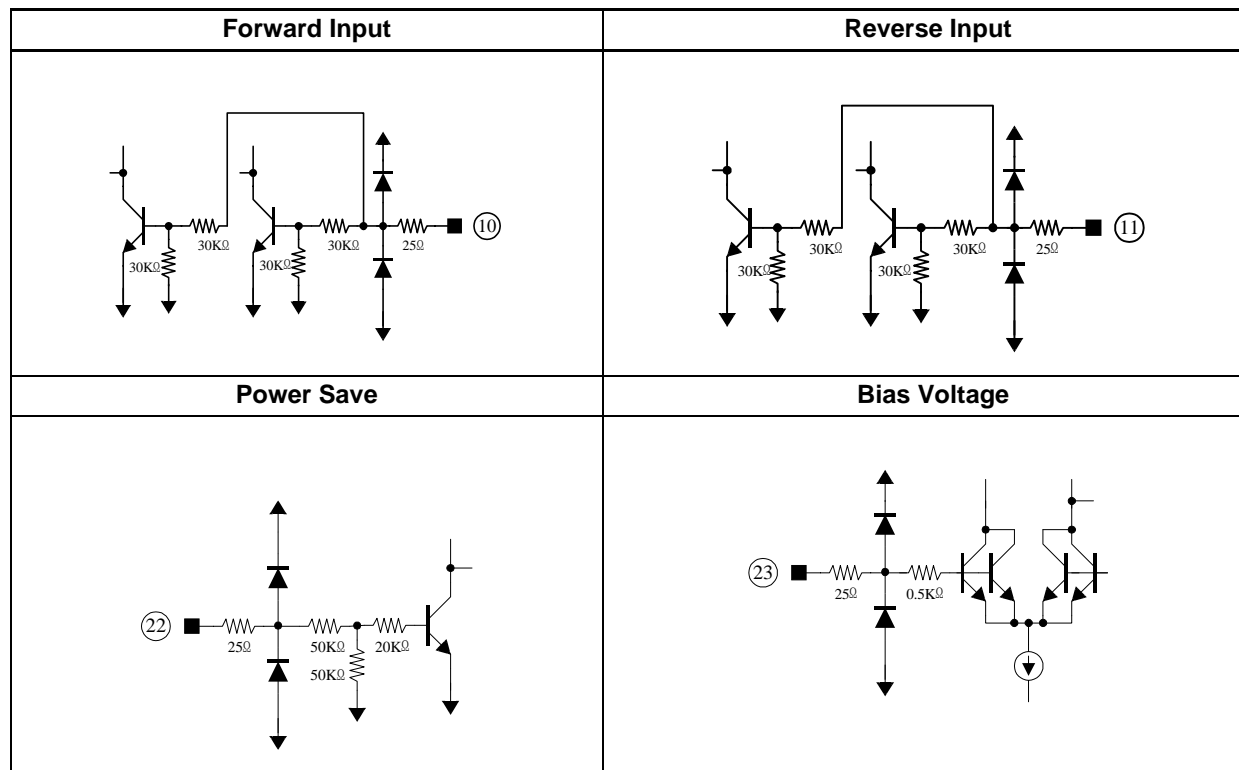

## Absolute Maximum Ratings (Ta = 25°C)

Parameter	Symbol	Value	Unit
Maximum Supply Voltage	VCC	18	V
Power Dissipation	PD	2.5 <sup>note</sup>	W
Operating Temperature	TOPR	-35 ~ +85	°C
Storage Temperature	TSTG	-55 ~ +150	°C
Maximum output current	IOMAX	1	A
Regulator Maximum output current	IROMAX	400	mA

### Notes:

- When mounted on 70mm × 70mm × 1.6mm PCB
- Power dissipation reduces 20mW/°C for using above TA = 25°C
- Do not exceed PD and SOA (Safe Operating Area)

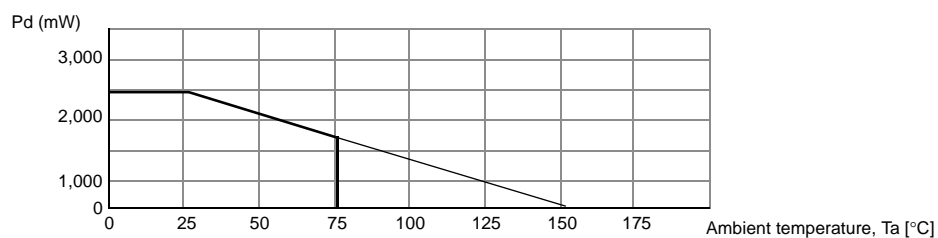

## Recommended Operating Conditions (Ta = 25°C)

Parameter	Symbol	Min.	Typ.	Max.	Unit
Operating Supply Voltage	Vcc	4.5	-	13.2	V
Vctl(pin9) Voltage(Vcc=Vcc1=8V)	Vctl	0	-	3.0	V
Vctl(pin9) Voltage(Vcc=Vcc1=5V)	Vctl	0	-	1.6	V

## Electrical Characteristics

(VCC = VCC1 = 8V, TA = 25°C, unless otherwise specified)

Characteristics	Symbol	Condition	Min.	Typ.	Max.	Unit
Quiescent Circuit Current	ICCQ	Under no - load	-	20	-	mA
Power Save On Current	IPS	Pin7=GND	-	1	2	mA
Power Save On Voltage	VPSON	Pin7=Variation	-	-	0.5	V
Power Save Off Voltage	VPSOFF	Pin7=Variation	2	-	-	V
<b>VARIABLE REGULATOR PART</b>						
Load Regulation	$\Delta V_{RL}$	$I_L = 0\text{mA} \rightarrow 200\text{mA}$	-40	0	10	mV
Line Regulation	$\Delta V_{CC}$	$I_L = 200\text{mA}, V_{CC}=6\text{V} \rightarrow 9\text{V}$	-20	0	30	mV
Regulator Output Voltage 1	VREG1	$I_L = 100\text{mA}$	4.75	5	5.25	V
Regulator Output Voltage 2	VREG2	$I_L = 100\text{mA}$	3.135	3.3	3.465	V
Regulator Output Peak Current (Note1)	IPK	$T_j = 25^\circ\text{C}$		700		mA
<b>BLT DRIVER PART</b>						
Output Offset Voltage	VOO	$V_{IN}=2.5\text{V}$	-40	0	40	mV
Maximum Output Voltage1	VOM1	$V_{CC}=V_{CC1}=8\text{V}, R_L = 12\Omega$	5.5	6.5	-	V
Maximum Output Voltage2	VOM2	$V_{CC}=V_{CC1}=13\text{V}, R_L = 24\Omega$	10.5	11.5	-	V
Close Loop Voltage Gain	AVF	$V_{IN}=0\text{V}, 1\text{V}_{rms}, f = 1\text{KHz}$	10.5	12	13.5	dB
Slew rate	SR	$V_{OUT}=4\text{VP-P}, f = 120\text{KHz}, \text{Square}$	-	2	-	V/ $\mu\text{s}$
<b>LOADING MOTOR DRIVER PART</b>						
Input High Level Voltage	V <sub>IH</sub>	-	2	-	-	V
Input Low Level Voltage	V <sub>IL</sub>	-	-	-	0.5	V
Output Voltage1	V <sub>O1</sub>	$V_{CC}=V_{CC1}=5\text{V}, V_{ct1}=1.8\text{V}, R_L = 12\Omega$	2.6	3.6		
Output Voltage2	V <sub>O2</sub>	$V_{CC}=V_{CC1}=8\text{V}, V_{ct1}=3.2\text{V}, R_L = 12\Omega$	5.5	6.5	-	V
Output Offset Voltage1	V <sub>OO1</sub>	$V_{IN}=5\text{V}, 5\text{V}$	-40	-	40	mV
Output Offset Voltage2	V <sub>OO2</sub>	$V_{IN}=0\text{V}, 0\text{V}$	-40	-	40	mV

### Note:

1. Pulse Testing with Low Duty.

## Application Information

### 1. Driver (Except For Loading Motor Driver)

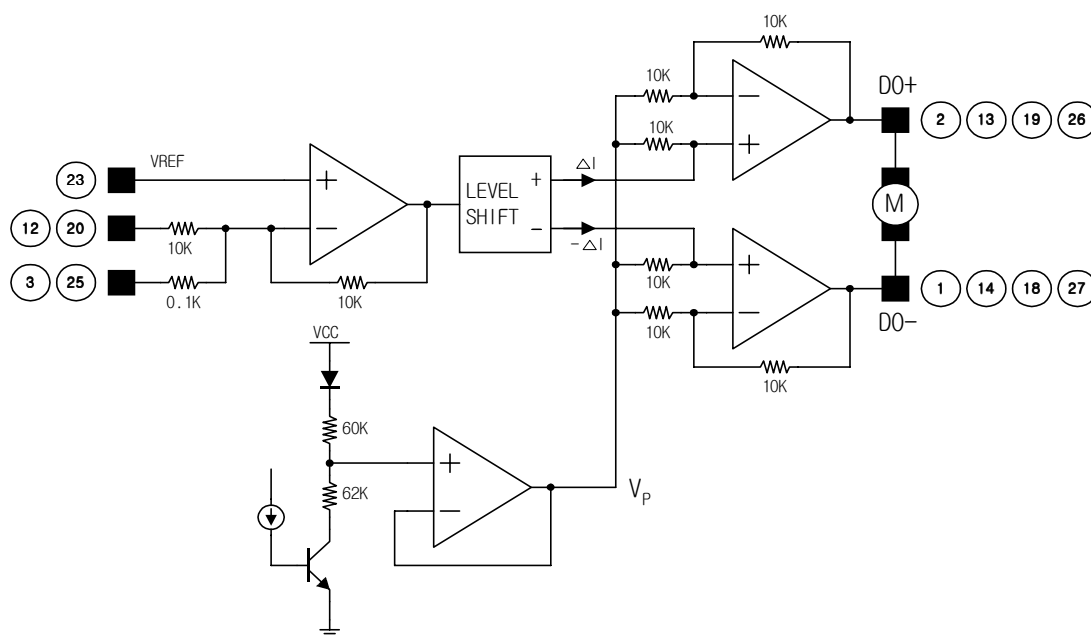

A voltage,  $V_{REF}$  is the reference voltage driven by the external bias voltage on pin#23. The input signal ( $V_{in}$ ) on pin#12 and #20 is uplifted by  $10K/10K$  times and then fed to the level shift. The level shift provides a current as  $+\Delta I$  and  $-\Delta I$  due to the difference between the input signal and the arbitrary reference signal. The current can be fed into the driver Amp, so it drives the power TR on the output stage. The output can be shown 2 times as much as the input signal. (gain =  $1 + 10K/10K$ ).

$$V_{IN} = V_{REF} + \Delta V \Delta I = \frac{\Delta V}{10K}$$

$$DO+ = V_P + \Delta I \cdot 10K \cdot \left(1 + \frac{10K}{10K}\right) = V_P + 2\Delta V$$

$$DO- = V_P - \Delta I \cdot 10K \cdot \left(1 + \frac{10K}{10K}\right) = V_P - 2\Delta V$$

$$V_{OUT} = (DO+) - (DO-) = 4\Delta V$$

$$GAIN = 20 \log \left( \frac{V_{OUT}}{\Delta V} \right) = 12dB$$

Pin#3 or #25 can be used to modify the gain. The output stage is the balanced transformerless (BTL) driver. The bias voltage  $V_P$  is described as follows.

$$\begin{aligned} V_P &= (V_{CC} - V_{BE} - V_{CE(SAT)}) \times \frac{62K}{60K + 62K} + V_{CE(SAT)} \\ &= \frac{V_{CC} - V_{BE} - V_{CE(SAT)}}{1.97} + V_{CE(SAT)} \end{aligned}$$



## 2. Thermal Shutdown

The TSD circuit turns activated when the junction temperature becomes over 175°C.

It cuts off the bias current on the output driver and keeps all the output drivers off. Meanwhile, the junction temperature begins to decrease.

The TSD circuit can be deactivated when the junction temperature falls under 150°C, so the output driver begins operating in normal condition. The TSD circuit has the hysteresis temperature of 25°C.

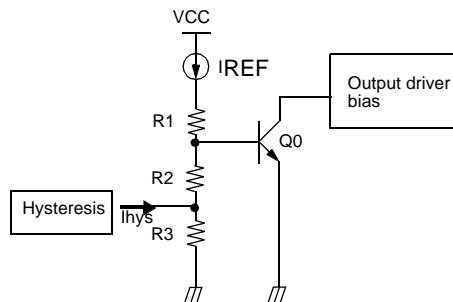

## 3. Power Save Function

When the pin22 is high, the TR Q3 is turned on and Q4 is off, so the bias circuit is enabled. On the other hand, when the pin22 is Low (GND), the TR Q3 is turned off and Q4 is on, so the bias circuit is disabled.

that is, it will make all the circuit blocks except for variable regulator off, so low power quiescent state can be established. Truth table is as follows.

Pin#22	FAN8039BD3
High	Power Save Off
Low	Power Save On

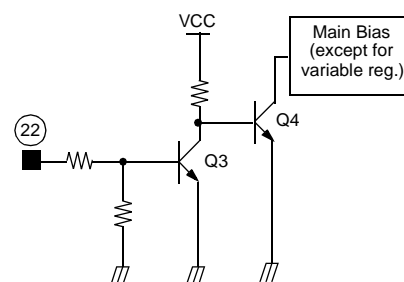

## 4. Variable Regulator

A 33uF capacitor is used as a ripple eliminator in the external circuit. Therefore, output voltage,  $V_{out}$  can be calculated as follows.

$$V_{OUT} = V_{REF} \cdot \left(1 + \frac{R_1}{R_2}\right) = 2.5 \times 2 = 5V (R_1 = R_2)$$

In order to reduce the heating problem on regulator output TR, Q1, a resistor R3 can be used and calculated as follows.

$$R_3 = \frac{(REGVCC - (V_{out} + 1.5))}{I_{MAX}}$$

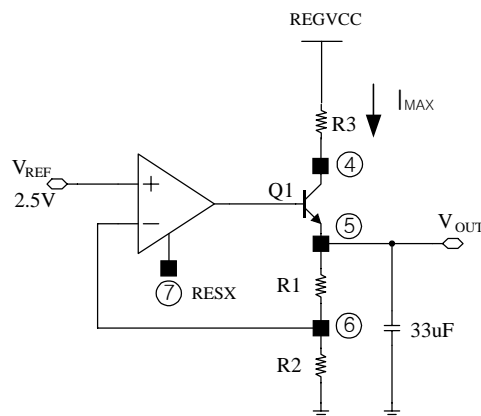

## 5. Loading Motor Driver

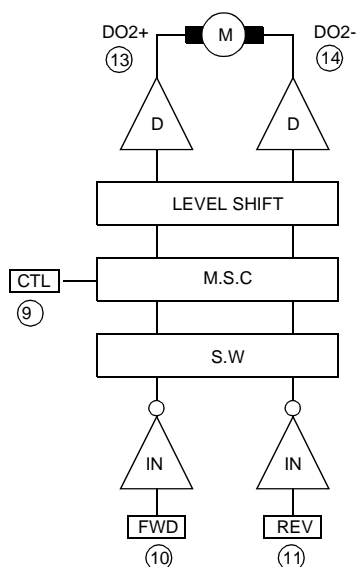

- Rotational direction control

The forward and reverse rotational direction is controlled by FWD (pin10) and REV (pin11) , so the conditions are as follows.

INPUT		OUTPUT		
FWD	REV	OUT 1	OUT 2	State
H	H	Vp	Vp	Short Brake.
H	L	H	L	Forward
L	H	L	H	Reverse
L	L	Vb	Vb	High Impedance

- Vp(Power Bias voltage) can be approximately 3.75V where Vcc1 and Vcc are 8V.
- Vb(Brake Bias voltage) can be approximately 1.7V where Vcc1 and Vcc are 8V.
- Motor speed control (Where VCC=VCC1=8V)
  - The maximum torque can be obtained when the pin 9(CTL) is open.
  - If the voltage on pin 9(CTL) is 0V, the motor will not be operating.

## Typical Performance Characteristics

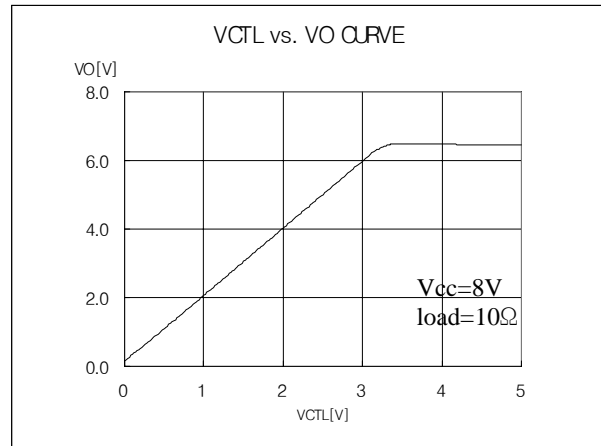
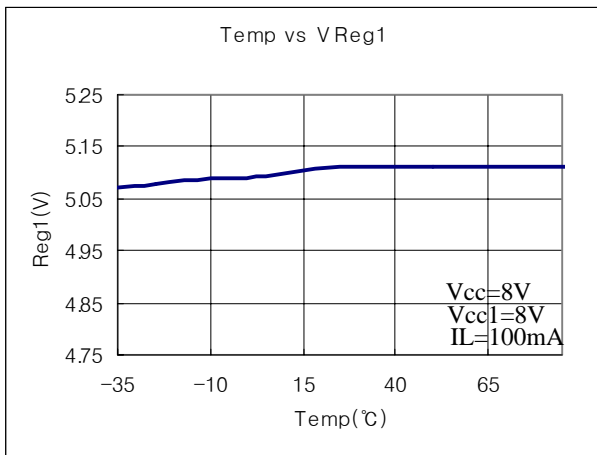
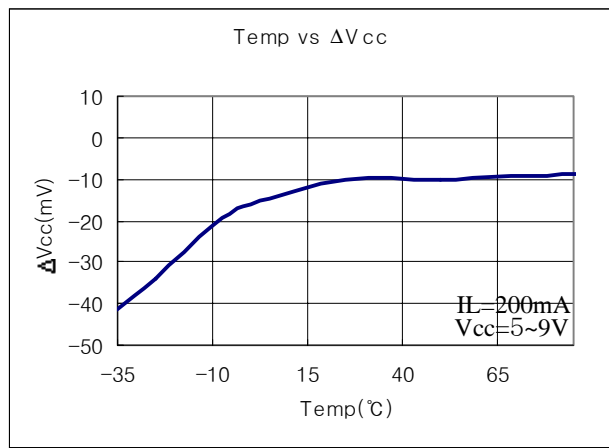
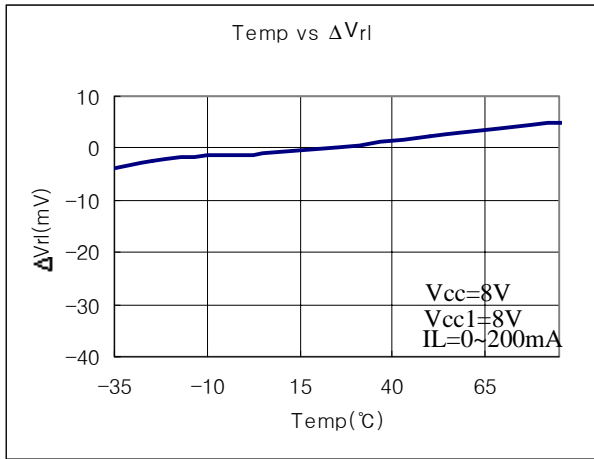
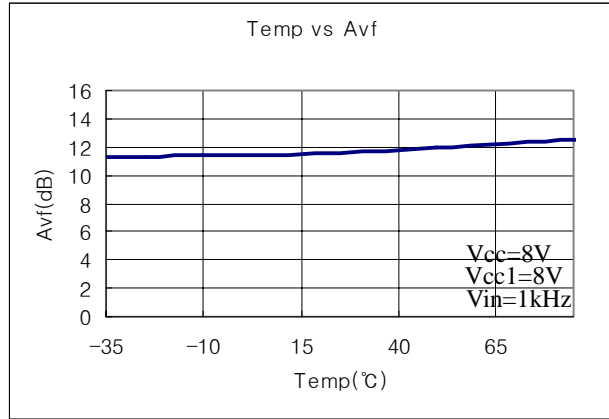
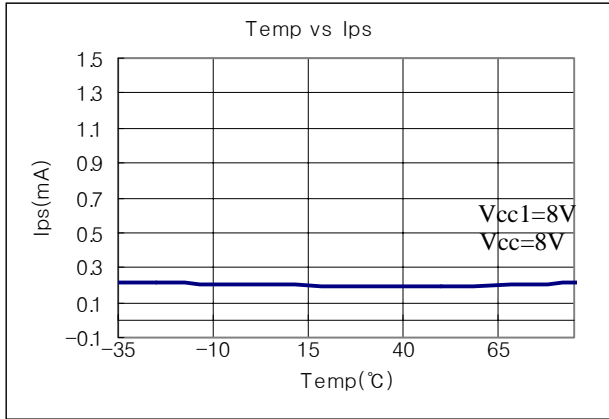

Typical Performance Characteristics(Continued)

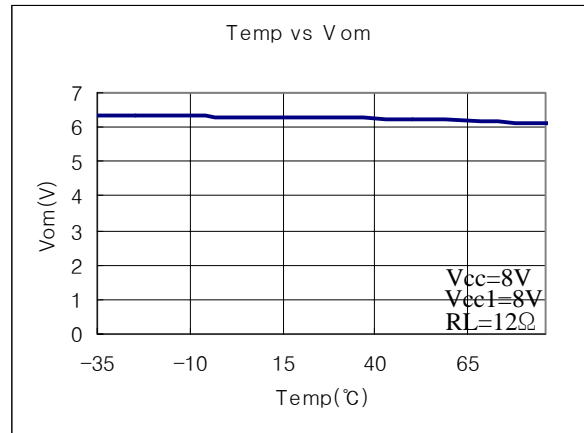
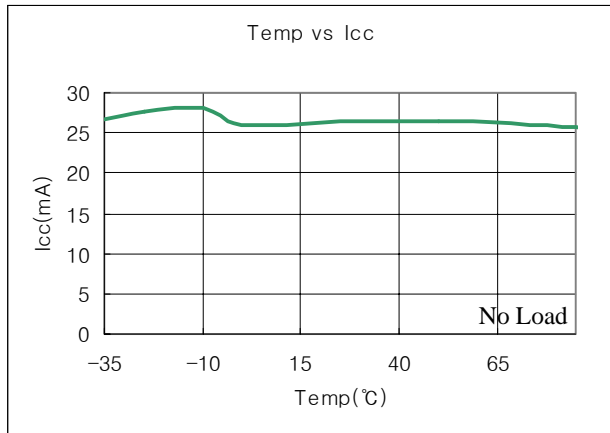
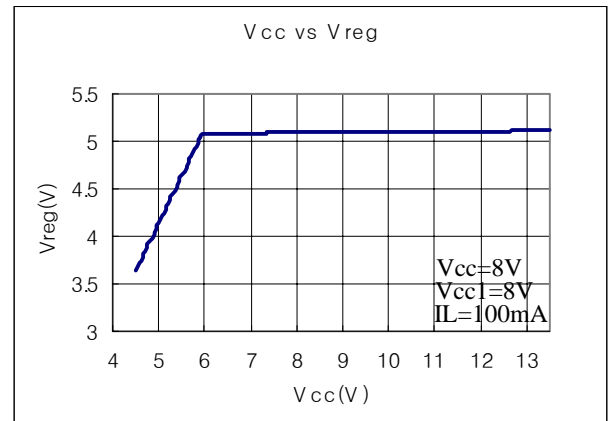
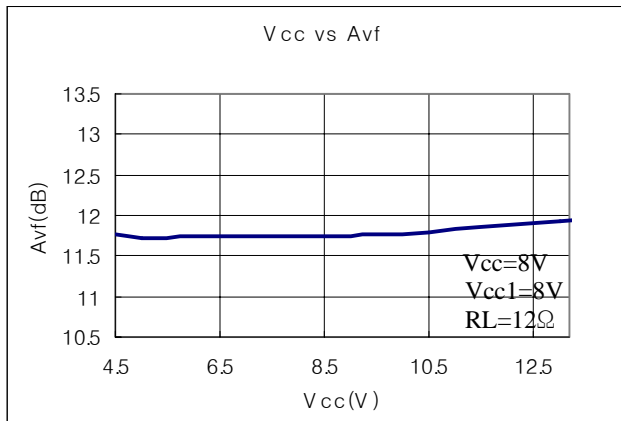
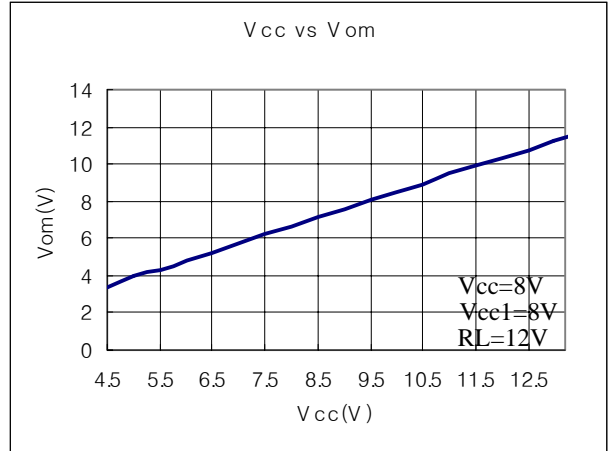
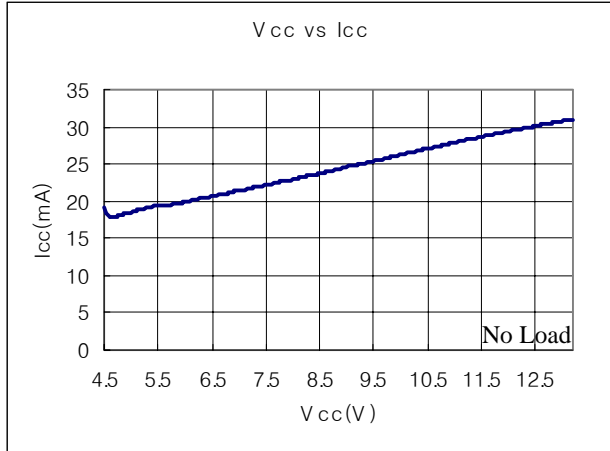

## Test Circuit

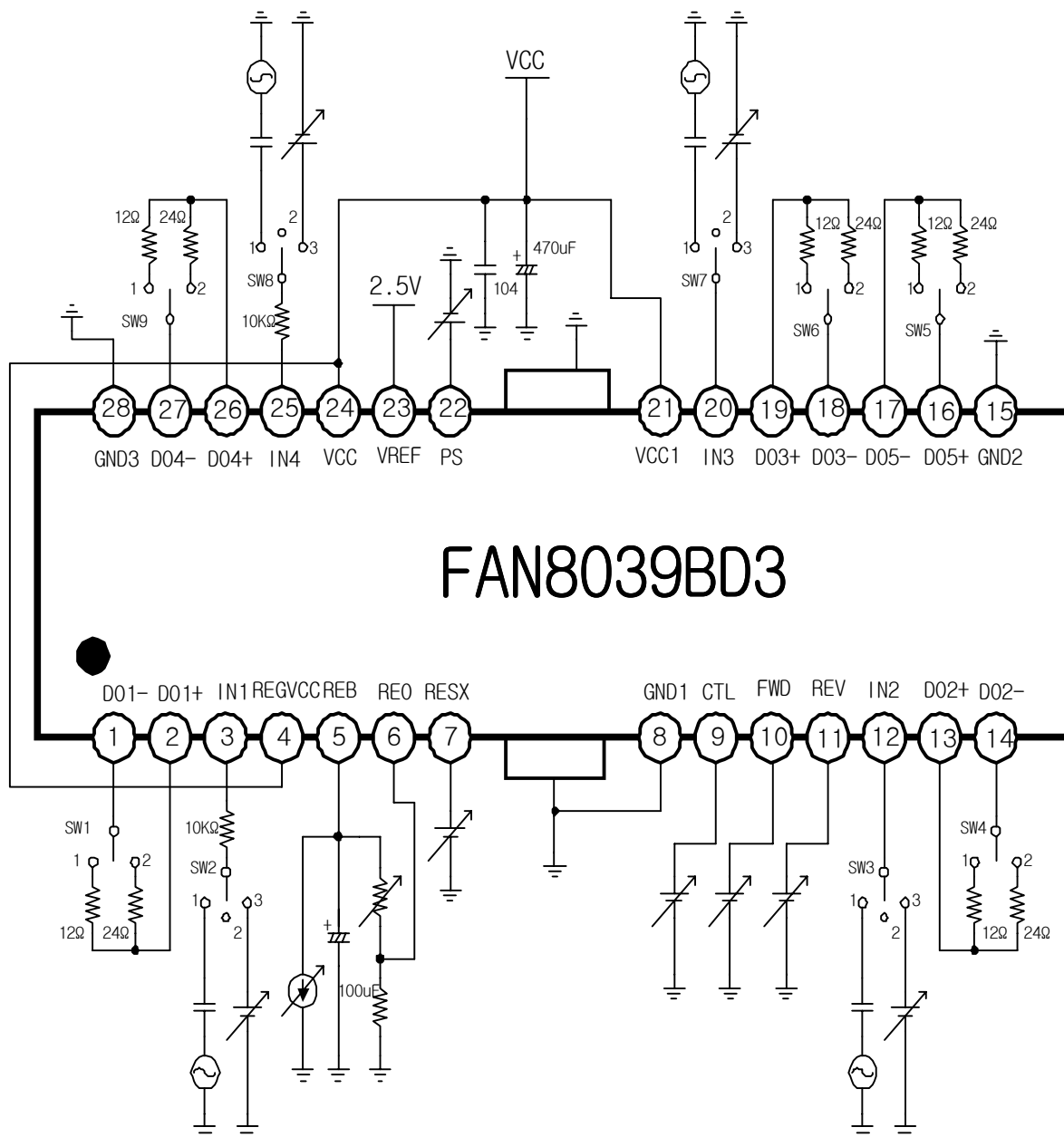

# Application Circuit

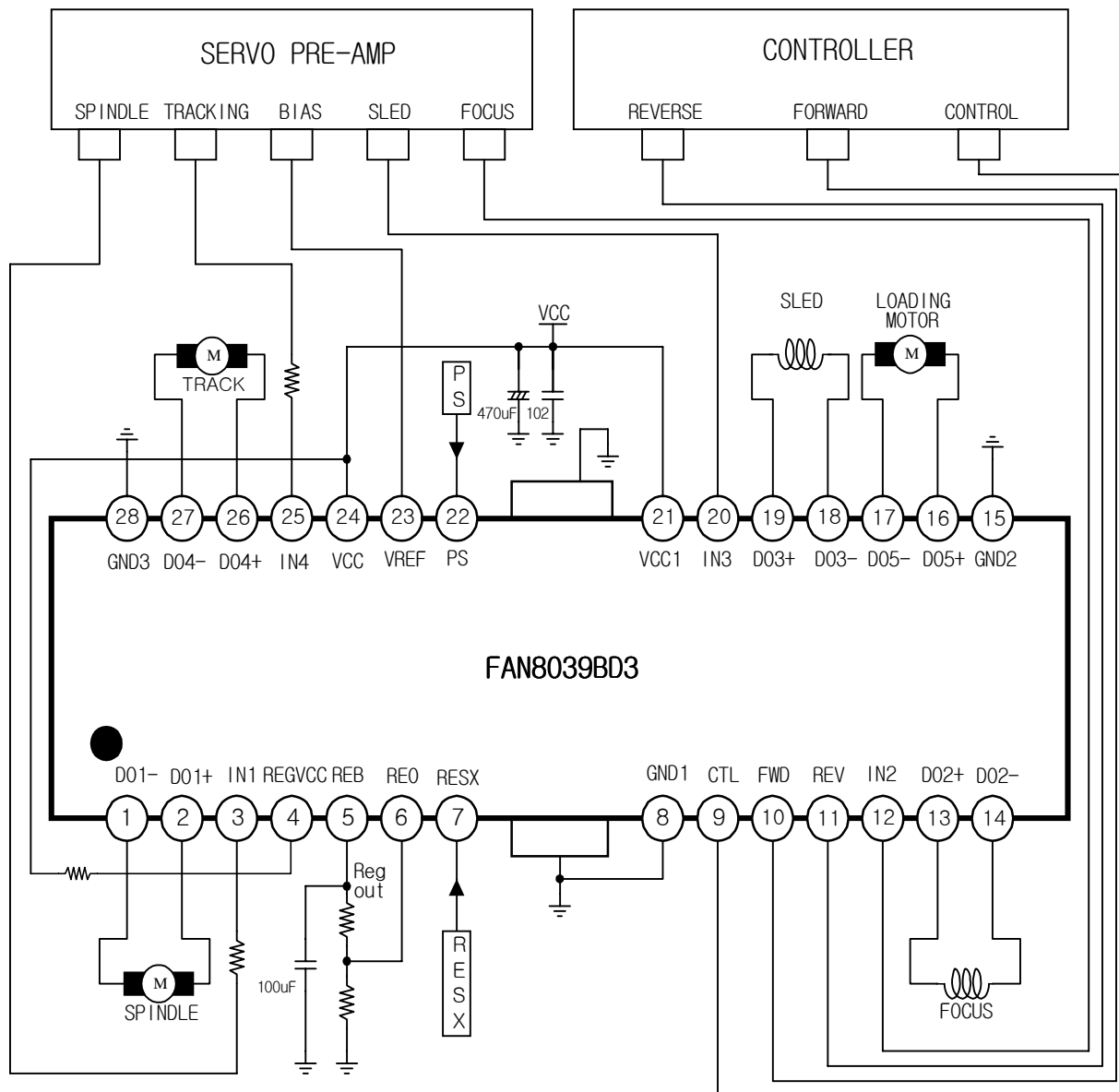



**DISCLAIMER**

FAIRCHILD SEMICONDUCTOR RESERVES THE RIGHT TO MAKE CHANGES WITHOUT FURTHER NOTICE TO ANY PRODUCTS HEREIN TO IMPROVE RELIABILITY, FUNCTION OR DESIGN. FAIRCHILD DOES NOT ASSUME ANY LIABILITY ARISING OUT OF THE APPLICATION OR USE OF ANY PRODUCT OR CIRCUIT DESCRIBED HEREIN; NEITHER DOES IT CONVEY ANY LICENSE UNDER ITS PATENT RIGHTS, NOR THE RIGHTS OF OTHERS.

**LIFE SUPPORT POLICY**

FAIRCHILD'S PRODUCTS ARE NOT AUTHORIZED FOR USE AS CRITICAL COMPONENTS IN LIFE SUPPORT DEVICES OR SYSTEMS WITHOUT THE EXPRESS WRITTEN APPROVAL OF THE PRESIDENT OF FAIRCHILD SEMICONDUCTOR CORPORATION. As used herein:

1. Life support devices or systems are devices or systems which, (a) are intended for surgical implant into the body, or (b) support or sustain life, and (c) whose failure to perform when properly used in accordance with instructions for use provided in the labeling, can be reasonably expected to result in a significant injury of the user.
2. A critical component in any component of a life support device or system whose failure to perform can be reasonably expected to cause the failure of the life support device or system, or to affect its safety or effectiveness.