

# DS3486

## Quad RS-422, RS-423 Line Receiver

### General Description

National's quad RS-422, RS-423 receiver features four independent receivers which comply with EIA Standards for the electrical characteristics of balanced/unbalanced voltage digital interface circuits. Receiver outputs are 74LS compatible, TRI-STATE® structures which are forced to a high impedance state when the appropriate output control pin reaches a logic zero condition. A PNP device buffers each output control pin to assure minimum loading for either logic one or logic zero inputs. In addition, each receiver has internal hysteresis circuitry to improve noise margin and discourage output instability for slowly changing input waveforms.

### Features

- Four independent receivers
- TRI-STATE outputs
- Internal hysteresis –140 mV (typ)
- Fast propagation times –19 ns (typ)
- TTL compatible outputs
- 5V supply
- Pin compatible and interchangeable with MC3486

### Block and Connection Diagrams

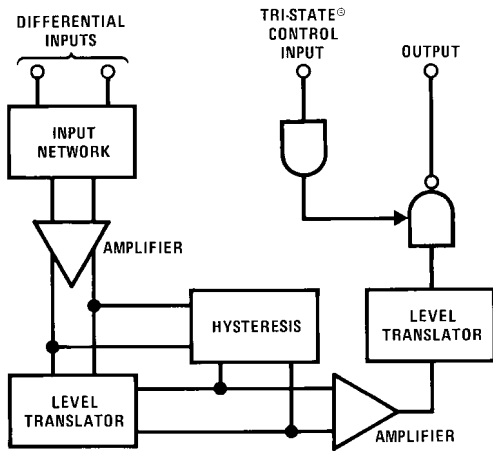

577901

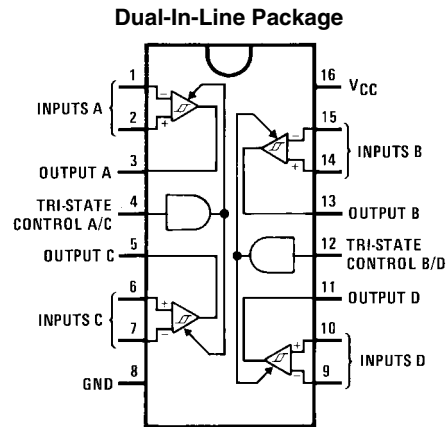

577902

**Top View**  
Order Number DS3486M or DS3486N  
See NS Package Number M16A or N16E

**Absolute Maximum Ratings** (Note 2)

If Military/Aerospace specified devices are required, please contact the National Semiconductor Sales Office/Distributors for availability and specifications.

Power Supply Voltage, $V_{CC}$	8V
Input Common-Mode Voltage, $V_{ICM}$	$\pm 25V$
Input Differential Voltage, $V_{ID}$	$\pm 25V$
TRI-STATE Control Input Voltage, $V_I$	8V
Output Sink Current, $I_O$	50 mA
Storage Temperature, $T_{STG}$	$-65^\circ C$ to $+150^\circ C$
Maximum Power Dissipation (Note 1) at $25^\circ C$	
Molded Dip Package	1362 mW

SO Package

1002 mW

SO Package Thermal Resistance

 $\theta_{JA}$  $+124.5^\circ C/W$  $\theta_{JC}$  $+41.2^\circ C/W$ **Operating Conditions**

	Max	Min	Units
Power Supply Voltage, $V_{CC}$	4.75	5.25	V
Operating Temperature, $T_A$	0	70	$^\circ C$
Input Common-Mode Voltage Range, $V_{ICR}$	-7.0	7.0	V

**Note 1:** Derate Dip molded package 10.2 mW/ $^\circ C$  above  $25^\circ C$ . Derate SO package 8.01 mW/ $^\circ C$  above  $25^\circ C$ .

**Electrical Characteristics** (Note 3)

(Unless otherwise noted, minimum and maximum limits apply over recommended temperature and power supply voltage ranges. Typical values are for  $T_A = 25^\circ C$ ,  $V_{CC} = 5V$  and  $V_{IC} = 0V$ .)

Symbol	Parameter	Conditions	Min	Typ	Max	Units	
$V_{IH}$	Input Voltage—High Logic State (TRI-STATE Control)		2.0			V	
$V_{IL}$	Input Voltage—Low Logic State (TRI-STATE Control)				0.8	V	
$V_{TH(D)}$	Differential Input Threshold Voltage	$-7V \leq V_{IC} \leq 7V$ , $V_{IH(3C)} = 2V$ $I_O = -0.4 mA$ , $V_{OH} \geq 2.7V$		0.070	0.2	V	
		$I_O = 8 mA$ , $V_{OL} \geq 0.5V$		0.070	-0.2	V	
$I_{IB(D)}$	Input Bias Current	$V_{CC} = 0V$ or $5.25V$ , Other Inputs at $0V$					
		$V_I = -10V$			-3.25	mA	
		$V_I = -3V$			-1.50	mA	
		$V_I = 3V$			1.50	mA	
		$V_I = 10V$			3.25	mA	
	Input Balance	$-7V \leq V_{IC} \leq 7V$ , $V_{IH(3C)} = 2V$ , (Note 5)					
		$V_{OH}$	$I_O = -0.4 mA$ , $V_{ID} = 0.4V$	2.7			V
		$V_{OL}$	$I_O = 8 mA$ , $V_{ID} = -0.4V$			0.5	V
$I_{OZ}$	Output TRI-STATE Leakage Current	$V_{I(D)} = 3V$ , $V_{IL} = 0.8V$ , $V_{OL} = 0.5V$			-40	$\mu A$	
		$V_{I(D)} = -3V$ , $V_{IL} = 0.8V$ , $V_{OH} = 2.7V$			40	$\mu A$	
$I_{OS}$	Output Short-Circuit Current	$V_{I(D)} = 3V$ , $V_{IH}$ TRI-STATE = $2V$ , $V_O = 0V$ , (Note 4)	-15		-100	mA	
$I_{IL}$	Input Current—Low Logic State (TRI-STATE Control)	$V_{IL} = 0.5V$			-100	$\mu A$	
$I_{IH}$	Input Current—High Logic State (TRI-STATE Control)	$V_{IH} = 2.7V$			20	$\mu A$	
		$V_{IH} = 5.25V$			100	$\mu A$	
$V_{IC}$	Input Clamp Diode Voltage (TRI-STATE Control)	$I_{IN} = -10 mA$			-1.5	V	
$I_{CC}$	Power Supply Current	All Inputs $V_{IL} = 0V$			85	mA	

**Note 2:** "Absolute Maximum Ratings" are those values beyond which the safety of the device cannot be guaranteed. They are not meant to imply that the devices should be operated at these limits. The table of "Electrical Characteristics" provides conditions for actual device operation.

**Note 3:** All currents into device pins are shown as positive, out of device pins are negative. All voltages referenced to ground unless otherwise noted.

**Note 4:** Only one output at a time should be shorted.

**Note 5:** Refer to EIA RS-422/3 for exact conditions.

## Switching Characteristics

(Unless otherwise noted,  $V_{CC} = 5V$  and  $T_A = 25^\circ C$ .)

Symbol	Parameter	Min	Typ	Max	Units
$t_{PHL(D)}$	Propagation Delay Time—Differential Inputs to Output Output High to Low		19	35	ns
$t_{PLH(D)}$	Output Low to High		19	30	ns
$t_{PLZ}$	TRI-STATE Control to Output Output Low to TRI-STATE		23	35	ns
$t_{PHZ}$	Output High to TRI-STATE		25	35	ns
$t_{PZH}$	Output TRI-STATE to High		18	30	ns
$t_{PZL}$	Output TRI-STATE to Low		20	30	ns

## AC Test Circuit and Switching Time Waveforms

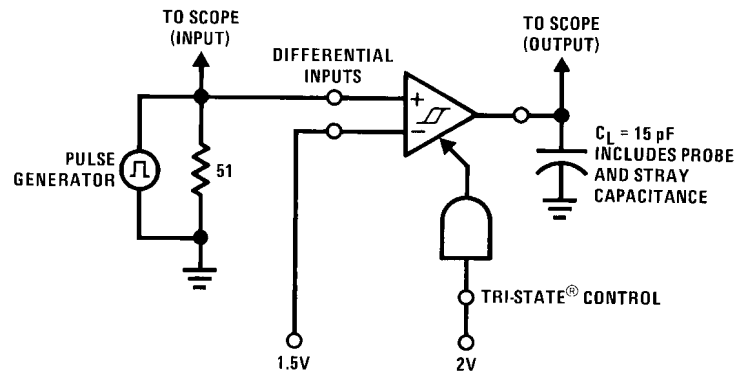

577903

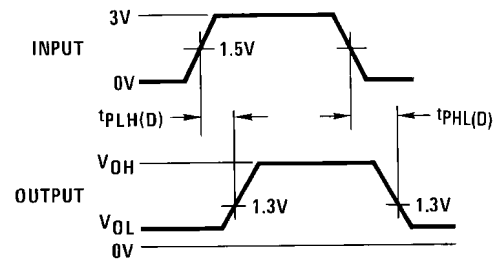

577904

Input pulse characteristics:

$t_{TLH} = t_{THL} = 6 \text{ ns}$  (10% to 90%)

PRR = 1 MHz, 50% duty cycle

FIGURE 1. Propagation Delay Differential Input to Output

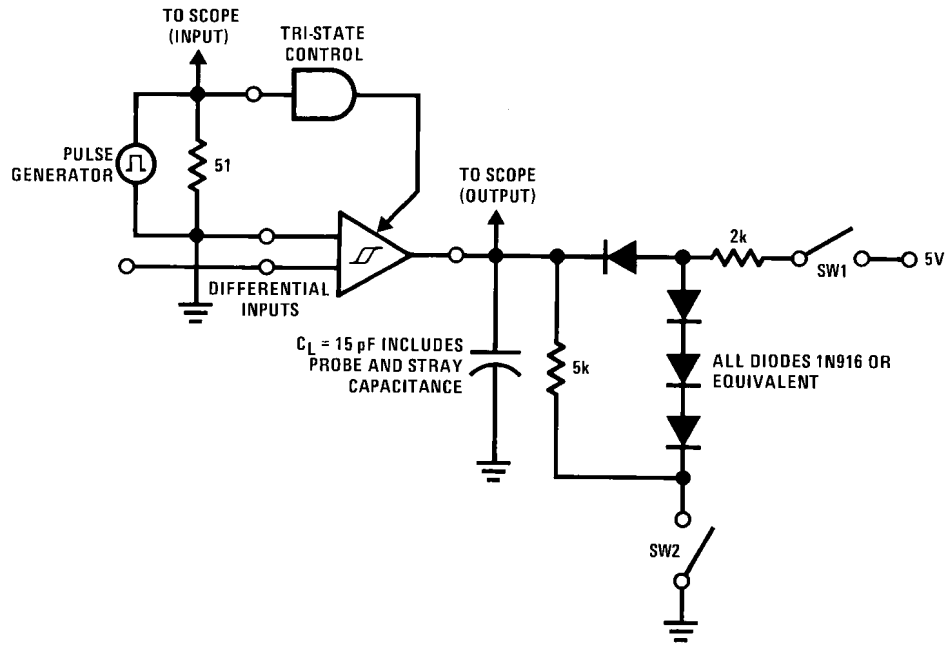

577905

1.5V for  $t_{PHZ}$  and  $t_{PLZ}$   
 1.5V for  $t_{PLZ}$  and  $t_{PZL}$   
 Input pulse characteristics:  
 $t_{TLH} = t_{THL} = 6 \text{ ns}$  (10% to 90%)  
 PRR = 1 MHz, 50% duty cycle

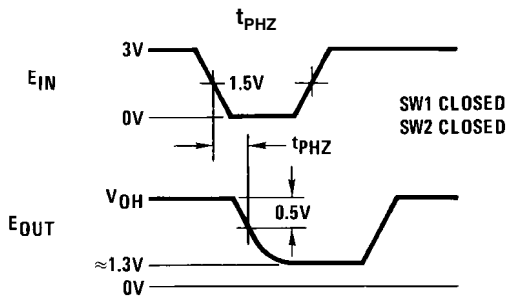
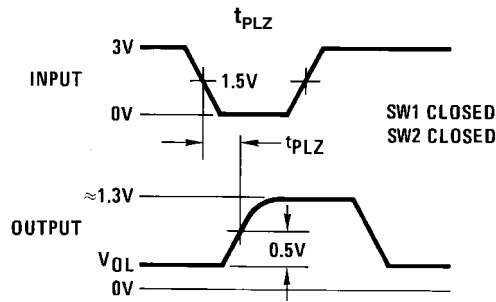

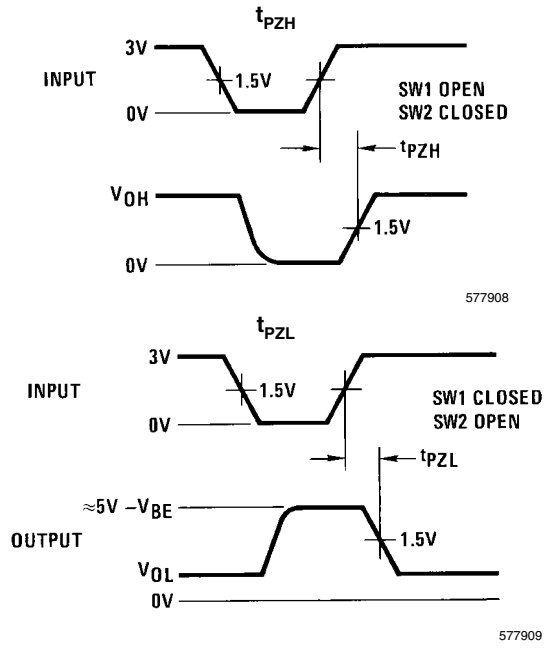
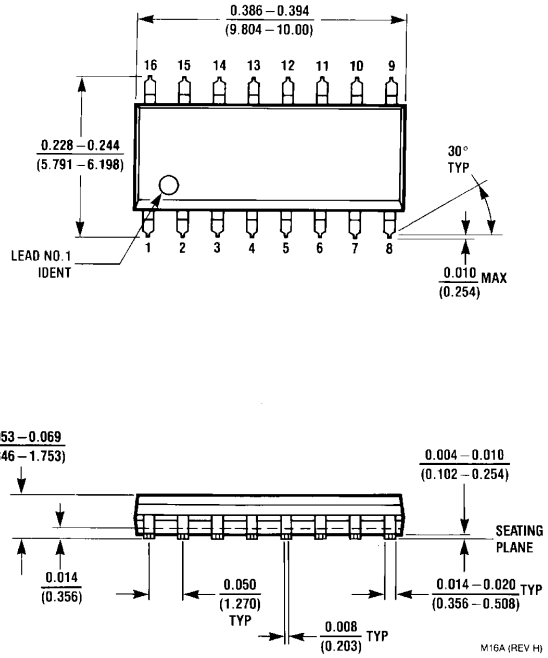
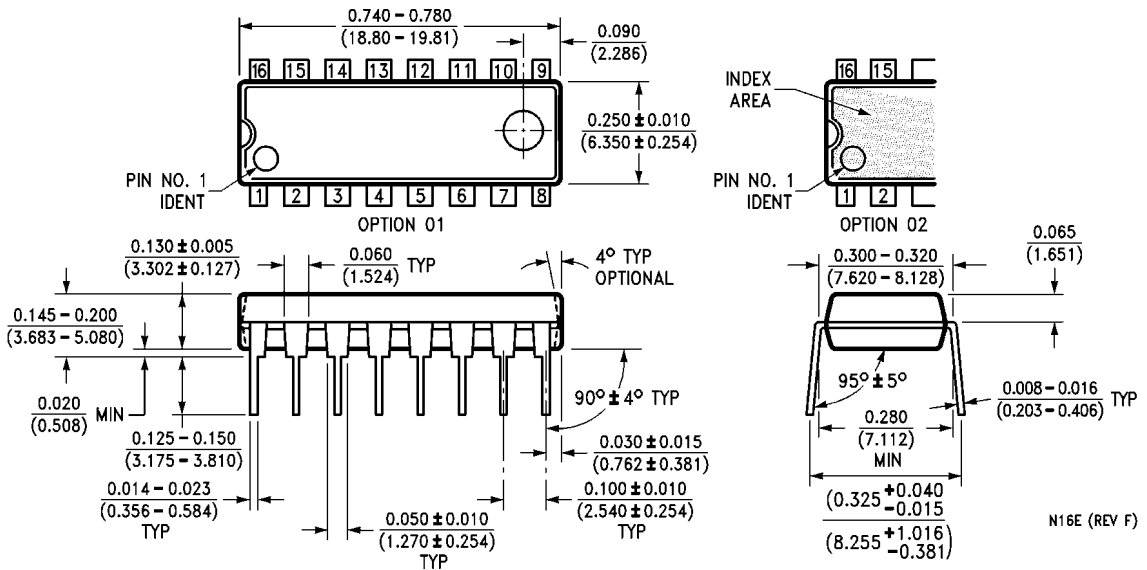

FIGURE 2. Propagation Delay TRI-STATE Control Input to Output

**Physical Dimensions** inches (millimeters) unless otherwise noted



**SO Package (M)**  
**Order Number DS3486M**  
**NS Package Number M16A**



**Molded Dual-In-Line Package (N)**  
**Order Number DS3486N**  
**NS Package Number N16E**

# Notes

DS3486

## Notes

THE CONTENTS OF THIS DOCUMENT ARE PROVIDED IN CONNECTION WITH NATIONAL SEMICONDUCTOR CORPORATION ("NATIONAL") PRODUCTS. NATIONAL MAKES NO REPRESENTATIONS OR WARRANTIES WITH RESPECT TO THE ACCURACY OR COMPLETENESS OF THE CONTENTS OF THIS PUBLICATION AND RESERVES THE RIGHT TO MAKE CHANGES TO SPECIFICATIONS AND PRODUCT DESCRIPTIONS AT ANY TIME WITHOUT NOTICE. NO LICENSE, WHETHER EXPRESS, IMPLIED, ARISING BY ESTOPPEL OR OTHERWISE, TO ANY INTELLECTUAL PROPERTY RIGHTS IS GRANTED BY THIS DOCUMENT.

TESTING AND OTHER QUALITY CONTROLS ARE USED TO THE EXTENT NATIONAL DEEMS NECESSARY TO SUPPORT NATIONAL'S PRODUCT WARRANTY. EXCEPT WHERE MANDATED BY GOVERNMENT REQUIREMENTS, TESTING OF ALL PARAMETERS OF EACH PRODUCT IS NOT NECESSARILY PERFORMED. NATIONAL ASSUMES NO LIABILITY FOR APPLICATIONS ASSISTANCE OR BUYER PRODUCT DESIGN. BUYERS ARE RESPONSIBLE FOR THEIR PRODUCTS AND APPLICATIONS USING NATIONAL COMPONENTS. PRIOR TO USING OR DISTRIBUTING ANY PRODUCTS THAT INCLUDE NATIONAL COMPONENTS, BUYERS SHOULD PROVIDE ADEQUATE DESIGN, TESTING AND OPERATING SAFEGUARDS.

EXCEPT AS PROVIDED IN NATIONAL'S TERMS AND CONDITIONS OF SALE FOR SUCH PRODUCTS, NATIONAL ASSUMES NO LIABILITY WHATSOEVER, AND NATIONAL DISCLAIMS ANY EXPRESS OR IMPLIED WARRANTY RELATING TO THE SALE AND/OR USE OF NATIONAL PRODUCTS INCLUDING LIABILITY OR WARRANTIES RELATING TO FITNESS FOR A PARTICULAR PURPOSE, MERCHANTABILITY, OR INFRINGEMENT OF ANY PATENT, COPYRIGHT OR OTHER INTELLECTUAL PROPERTY RIGHT.

### LIFE SUPPORT POLICY

**NATIONAL'S PRODUCTS ARE NOT AUTHORIZED FOR USE AS CRITICAL COMPONENTS IN LIFE SUPPORT DEVICES OR SYSTEMS WITHOUT THE EXPRESS PRIOR WRITTEN APPROVAL OF THE CHIEF EXECUTIVE OFFICER AND GENERAL COUNSEL OF NATIONAL SEMICONDUCTOR CORPORATION.** As used herein:

Life support devices or systems are devices which (a) are intended for surgical implant into the body, or (b) support or sustain life and whose failure to perform when properly used in accordance with instructions for use provided in the labeling can be reasonably expected to result in a significant injury to the user. A critical component is any component in a life support device or system whose failure to perform can be reasonably expected to cause the failure of the life support device or system or to affect its safety or effectiveness.

National Semiconductor and the National Semiconductor logo are registered trademarks of National Semiconductor Corporation. All other brand or product names may be trademarks or registered trademarks of their respective holders.

Copyright© 2007 National Semiconductor Corporation

For the most current product information visit us at [www.national.com](http://www.national.com)



**National Semiconductor  
Americas Customer  
Support Center**  
Email:  
[new.feedback@nsc.com](mailto:new.feedback@nsc.com)  
Tel: 1-800-272-9959

**National Semiconductor Europe  
Customer Support Center**  
Fax: +49 (0) 180-530-85-86  
Email: [europe.support@nsc.com](mailto:europe.support@nsc.com)  
Deutsch Tel: +49 (0) 69 9508 6208  
English Tel: +49 (0) 870 24 0 2171  
Français Tel: +33 (0) 1 41 91 8790

**National Semiconductor Asia  
Pacific Customer Support Center**  
Email: [ap.support@nsc.com](mailto:ap.support@nsc.com)

**National Semiconductor Japan  
Customer Support Center**  
Fax: 81-3-5639-7507  
Email: [jpn.feedback@nsc.com](mailto:jpn.feedback@nsc.com)  
Tel: 81-3-5639-7560