

Terminal Voltage $\pm 5V$, 64 Taps

X9241

Quad E²POT™ Nonvolatile Digital Potentiometer

FEATURES

- Four E²POTs in One Package
- Two-Wire Serial Interface
- Register Oriented Format
 - Directly Write Wiper Position
 - Read Wiper Position
 - Store as Many as Four Positions per Pot
- Instruction Format
 - Quick Transfer of Register Contents to Resistor Array
 - Cascade Resistor Arrays
- Low Power CMOS
- Direct Write Cell
 - Endurance - 100,000 Data Changes per Register
 - Register Data Retention - 100 years
- 16 Bytes of E²PROM memory
- 3 Resistor Array Values
 - 2K Ω to 50K Ω Mask Programmable
 - Cascadable For Values of 500 Ω to 200K Ω
- Resolution: 64 Taps each Pot
- 20-Lead Plastic DIP, 20-Lead TSSOP and 20-Lead SOIC Packages

DESCRIPTION

The X9241 integrates four nonvolatile E²POT digitally controlled potentiometers on a monolithic CMOS micro-circuit.

The X9241 contains four resistor arrays, each composed of 63 resistive elements. Between each element and at either end are tap points accessible to the wiper elements. The position of the wiper element on the array is controlled by the user through the two-wire serial bus interface.

Each resistor array has associated with it a wiper counter register and four 8-bit data registers that can be directly written and read by the user. The contents of the wiper counter register control the position of the wiper on the resistor array.

The data register may be read or written by the user. The contents of the data registers can be transferred to the wiper counter register to position the wiper. The current wiper position can be transferred to any one of its associated data registers.

The arrays may be cascaded to form resistive elements with 127, 190 or 253 taps.

FUNCTIONAL DIAGRAM

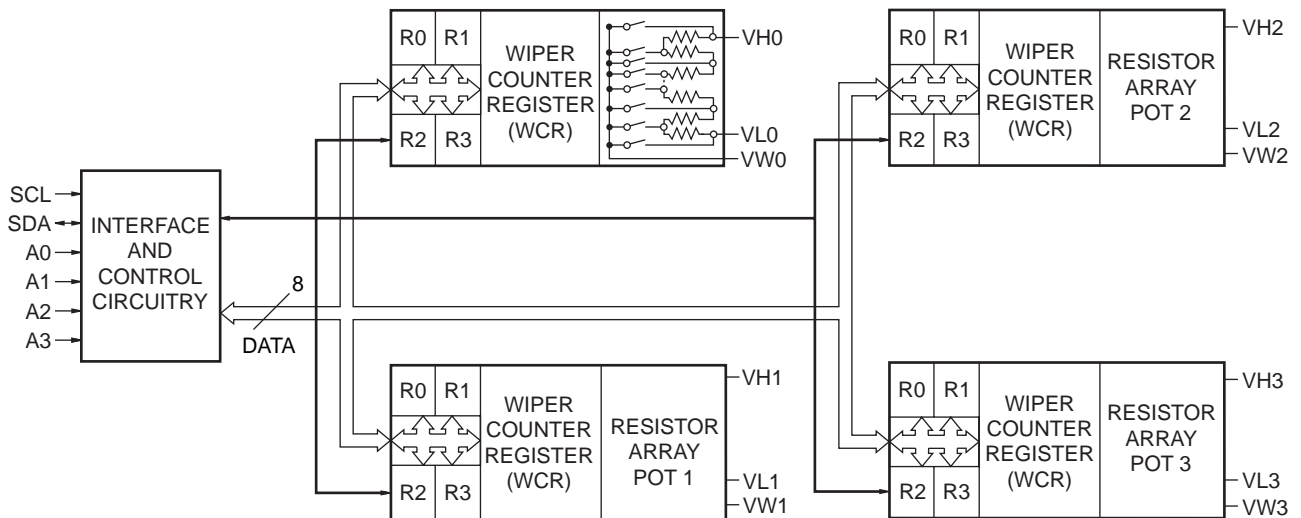

3864 ILL F07.1

X9241

PIN DESCRIPTIONS

Host Interface Pins

Serial Clock (SCL)

The SCL input is used to clock data into and out of the X9241.

Serial Data (SDA)

SDA is a bidirectional pin used to transfer data into and out of the device. It is an open drain output and may be wire-ORed with any number of open drain or open collector outputs. An open drain output requires the use of a pull-up resistor. For selecting typical values, refer to the guidelines for calculating typical values on the bus pull-up resistors graph.

Address

The Address inputs are used to set the least significant 4 bits of the 8-bit slave address. A match in the slave address serial data stream must be made with the Address input in order to initiate communication with the X9241.

Potentiometer Pins

V_H (V_{H0} – V_{H3}), V_L (V_{L0} – V_{L3})

The V_H and V_L inputs are equivalent to the terminal connections on either end of a mechanical potentiometer.

V_W (V_{W0} – V_{W3})

The wiper outputs are equivalent to the wiper output of a mechanical potentiometer.

PIN CONFIGURATION

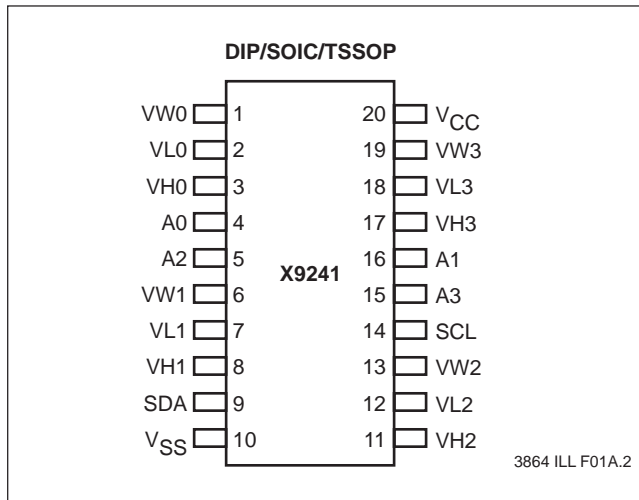

PIN NAMES

Symbol	Description
SCL	Serial Clock
SDA	Serial Data
A0–A3	Address
V _{H0} –V _{H3} , V _{L0} –V _{L3}	Potentiometers (terminal equivalent)
V _{W0} –V _{W3}	Potentiometers (wiper equivalent)

3864 PGM T01

PRINCIPLES OF OPERATION

The X9241 is a highly integrated microcircuit incorporating four resistor arrays, their associated registers and counters and the serial interface logic providing direct communication between the host and the E²POT potentiometers.

Serial Interface

The X9241 supports a bidirectional bus oriented protocol. The protocol defines any device that sends data onto the bus as a transmitter and the receiving device as the receiver. The device controlling the transfer is a master and the device being controlled is the slave. The master will always initiate data transfers and provide the clock for both transmit and receive operations. Therefore, the X9241 will be considered a slave device in all applications.

Clock and Data Conventions

Data states on the SDA line can change only during SCL LOW periods (t_{LOW}). SDA state changes during SCL HIGH are reserved for indicating start and stop conditions.

Start Condition

All commands to the X9241 are preceded by the start condition, which is a HIGH to LOW transition of SDA while SCL is HIGH (t_{HIGH}). The X9241 continuously monitors the SDA and SCL lines for the start condition and will not respond to any command until this condition is met.

Stop Condition

All communications must be terminated by a stop condition, which is a LOW to HIGH transition of SDA while SCL is HIGH.

X9241

Acknowledge

Acknowledge is a software convention used to provide a positive handshake between the master and slave devices on the bus to indicate the successful receipt of data. The transmitting device, either the master or the slave, will release the SDA bus after transmitting eight bits. The master generates a ninth clock cycle and during this period the receiver pulls the SDA line LOW to acknowledge that it successfully received the eight bits of data. See Figure 7.

The X9241 will respond with an acknowledge after recognition of a start condition and its slave address and once again after successful receipt of the command byte. If the command is followed by a data byte the X9241 will respond with a final acknowledge.

Array Description

The X9241 is comprised of four resistor arrays. Each array contains 63 discrete resistive segments that are connected in series. The physical ends of each array are equivalent to the fixed terminals of a mechanical potentiometer (V_H and V_L inputs).

At both ends of each array and between each resistor segment is a FET switch connected to the wiper (V_W) output. Within each individual array only one switch may be turned on at a time. These switches are controlled by the Wiper Counter Register (WCR). The six least significant bits of the WCR are decoded to select, and enable, one of sixty-four switches.

The WCR may be written directly, or it can be changed by transferring the contents of one of four associated data registers into the WCR. These data registers and the WCR can be read and written by the host system.

Device Addressing

Following a start condition the master must output the address of the slave it is accessing. The most significant four bits of the slave address are the device type identifier (refer to Figure 1 below). For the X9241 this is fixed as 0101[B].

Figure 1. Slave Address

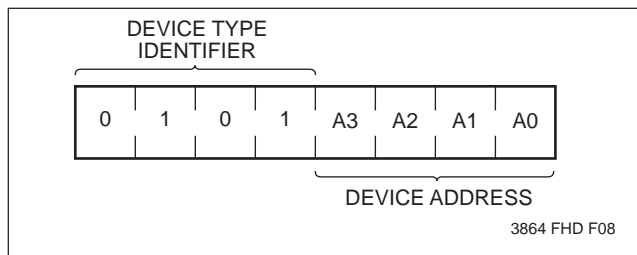

The next four bits of the slave address are the device address. The physical device address is defined by the state of the A0-A3 inputs. The X9241 compares the serial data stream with the address input state; a successful compare of all four address bits is required for the X9241 to respond with an acknowledge.

Acknowledge Polling

The disabling of the inputs, during the internal non-volatile write operation, can be used to take advantage of the typical 5ms E²PROM write cycle time. Once the stop condition is issued to indicate the end of the nonvolatile write command the X9241 initiates the internal write cycle. ACK polling can be initiated immediately. This involves issuing the start condition followed by the device slave address. If the X9241 is still busy with the write operation no ACK will be returned. If the X9241 has completed the write operation an ACK will be returned and the master can then proceed with the next operation.

Flow 1. ACK Polling Sequence

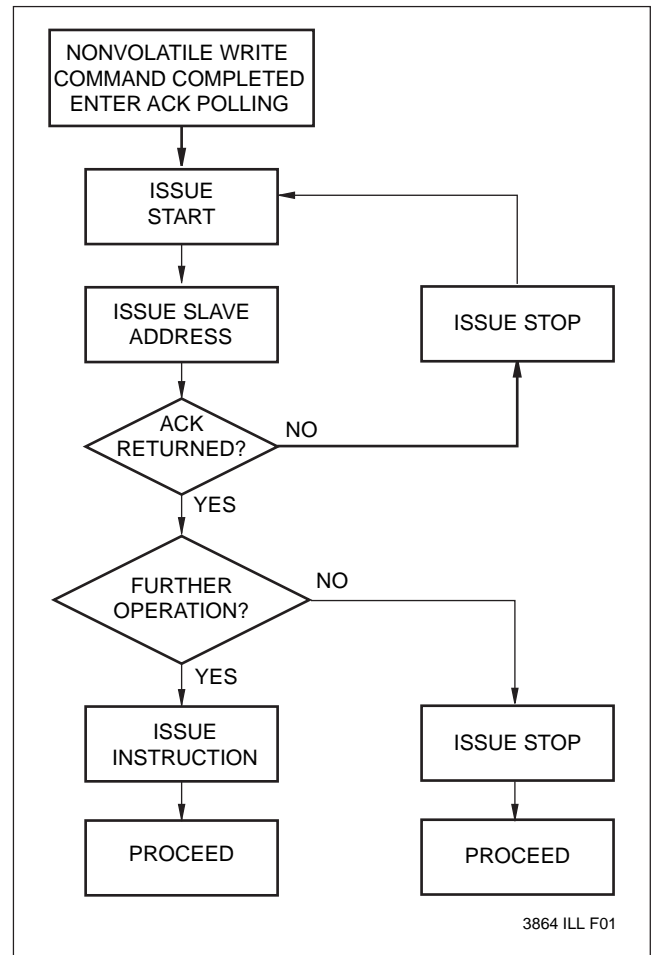

X9241

Instruction Structure

The next byte sent to the X9241 contains the instruction and register pointer information. The four most significant bits are the instruction. The next four bits point to one of four pots and when applicable they point to one of four associated registers. The format is shown below in Figure 2.

Figure 2. Instruction Byte Format

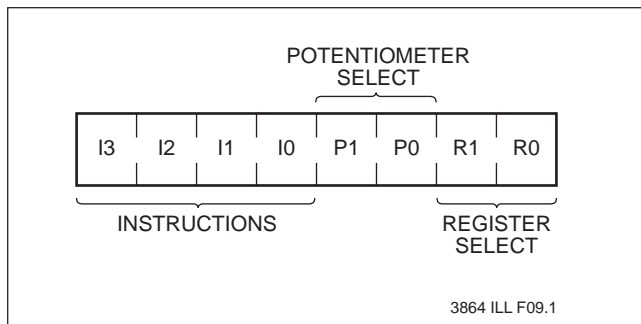

The four high order bits define the instruction. The next two bits (P1 and P0) select which one of the four potentiometers is to be affected by the instruction. The last two bits (R1 and R0) select one of the four registers that is to be acted upon when a register oriented instruction is issued.

Four of the nine instructions end with the transmission of the instruction byte. The basic sequence is illustrated in Figure 3. These two-byte instructions exchange data between the WCR and one of the data registers. A transfer from a data register to a WCR is essentially a write to a static RAM. The response of the wiper to this

action will be delayed t_{STPWV} . A transfer from WCR current wiper position, to a data register is a write to nonvolatile memory and takes a minimum of t_{WR} to complete. The transfer can occur between one of the four potentiometers and one of its associated registers; or it may occur globally, wherein the transfer occurs between all four of the potentiometers and one of their associated registers.

Four instructions require a three-byte sequence to complete. These instructions transfer data between the host and the X9241; either between the host and one of the data registers or directly between the host and the WCR. These instructions are: Read WCR, read the current wiper position of the selected pot; Write WCR, change current wiper position of the selected pot; Read Data Register, read the contents of the selected non-volatile register; Write Data Register, write a new value to the selected data register. The sequence of operations is shown in Figure 4.

The Increment/Decrement command is different from the other commands. Once the command is issued and the X9241 has responded with an acknowledge, the master can clock the selected wiper up and/or down in one segment steps; thereby, providing a fine tuning capability to the host. For each SCL clock pulse (t_{HIGH}) while SDA is HIGH, the selected wiper will move one resistor segment towards the V_H terminal. Similarly, for each SCL clock pulse while SDA is LOW, the selected wiper will move one resistor segment towards the V_L terminal. A detailed illustration of the sequence and timing for this operation are shown in Figures 5 and 6 respectively.

Figure 3. Two-Byte Command Sequence

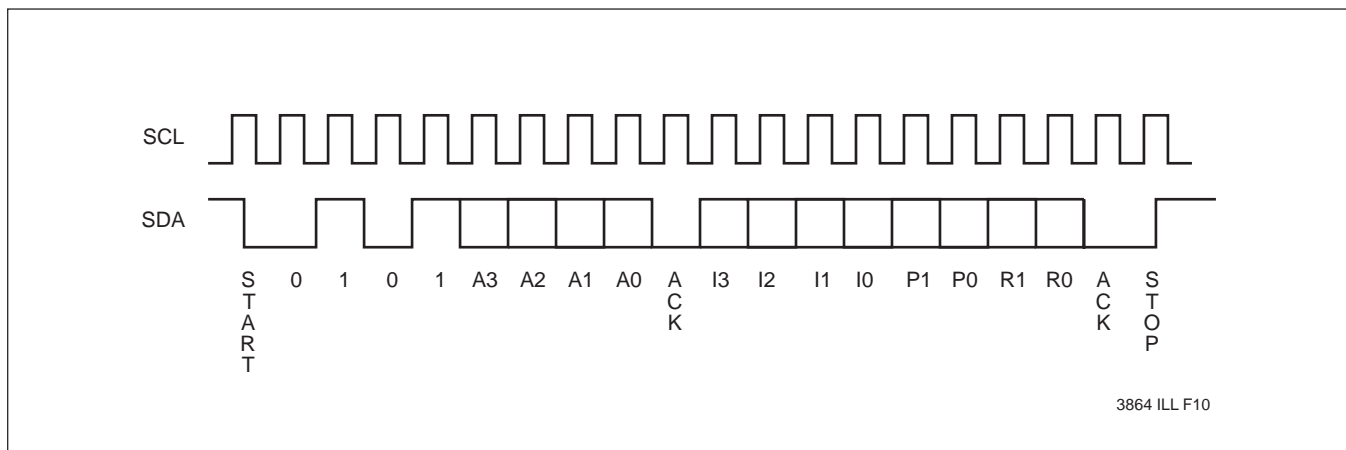

X9241

Figure 4. Three-Byte Command Sequence

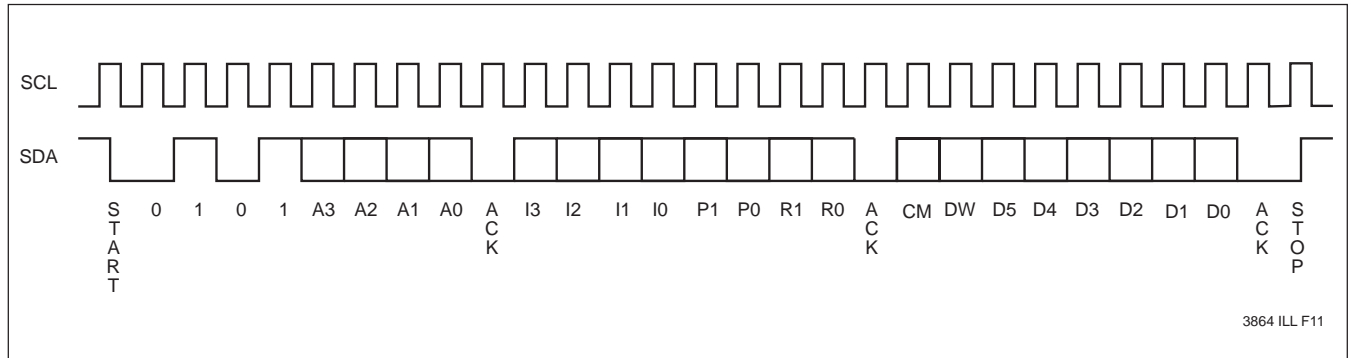

Figure 5. Increment/Decrement Command Sequence

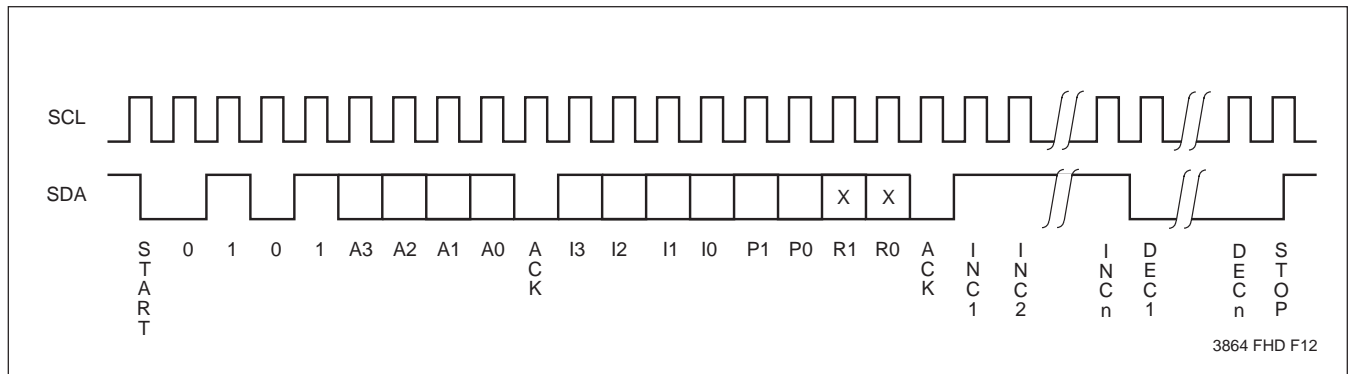

Figure 6. Increment/Decrement Timing Limits

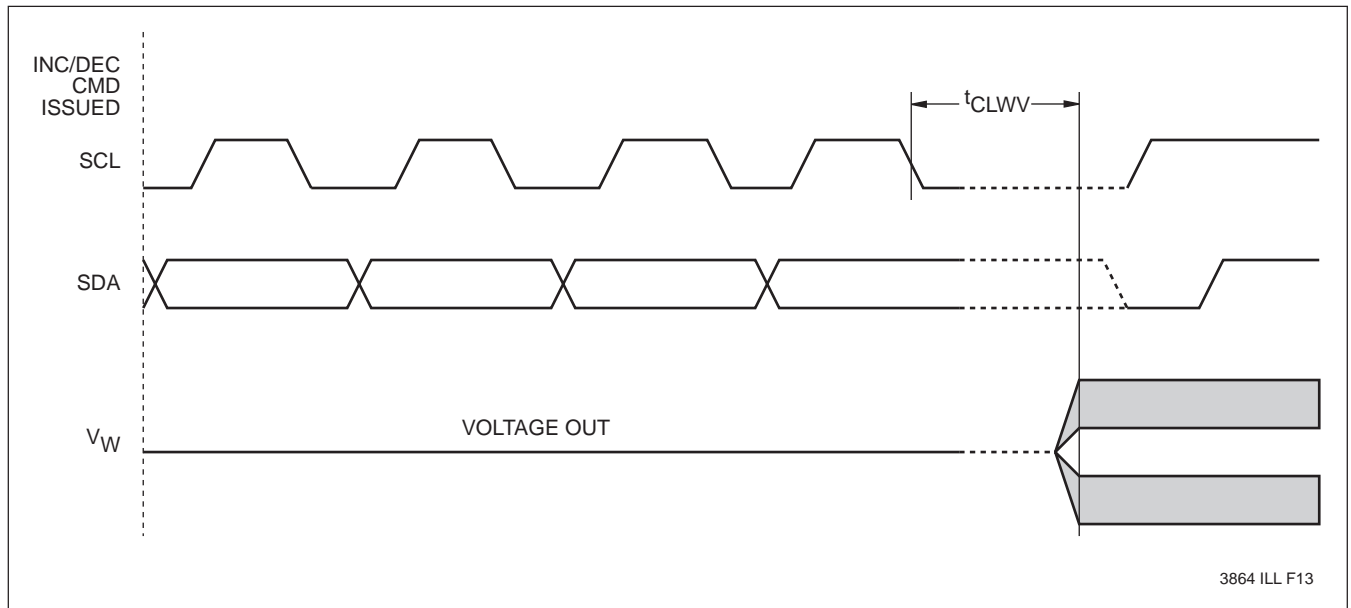

Table 1. Instruction Set

Instruction	Instruction Format								Operation
	I ₃	I ₂	I ₁	I ₀	P ₁	P ₀	R ₁	R ₀	
Read WCR	1	0	0	1	1/0 ⁽⁷⁾	1/0	N/A ⁽⁸⁾	N/A	Read the contents of the Wiper Counter Register pointed to by P ₁ –P ₀
Write WCR	1	0	1	0	1/0	1/0	N/A	N/A	Write new value to the Wiper Counter Register pointed to by P ₁ –P ₀
Read Data Register	1	0	1	1	1/0	1/0	1/0	1/0	Read the contents of the Register pointed to by P ₁ –P ₀ and R ₁ –R ₀
Write Data Register	1	1	0	0	1/0	1/0	1/0	1/0	Write new value to the Register pointed to by P ₁ –P ₀ and R ₁ –R ₀
XFR Data Register to WCR	1	1	0	1	1/0	1/0	1/0	1/0	Transfer the contents of the Register pointed to by P ₁ –P ₀ and R ₁ –R ₀ to its associated WCR
XFR WCR to Data Register	1	1	1	0	1/0	1/0	1/0	1/0	Transfer the contents of the WCR pointed to by P ₁ –P ₀ to the Register pointed to by R ₁ –R ₀
Global XFR Data Register to WCR	0	0	0	1	N/A	N/A	1/0	1/0	Transfer the contents of all four Data Registers pointed to by R ₁ –R ₀ to their respective WCR
Global XFR WCR to Data Register	1	0	0	0	N/A	N/A	1/0	1/0	Transfer the contents of all WCRs to their respective data Registers pointed to by R ₁ –R ₀
Increment/Decrement Wiper	0	0	1	0	1/0	1/0	N/A	N/A	Enable Increment/decrement of the WCR pointed to by P ₁ –P ₀

3864 PGM T02.1

Notes: (7) 1/0 = data is one or zero

(8) N/A = Not applicable or don't care; that is, a data register is not involved in the operation and need not be addressed (typical)

Figure 7. Acknowledge Response from Receiver

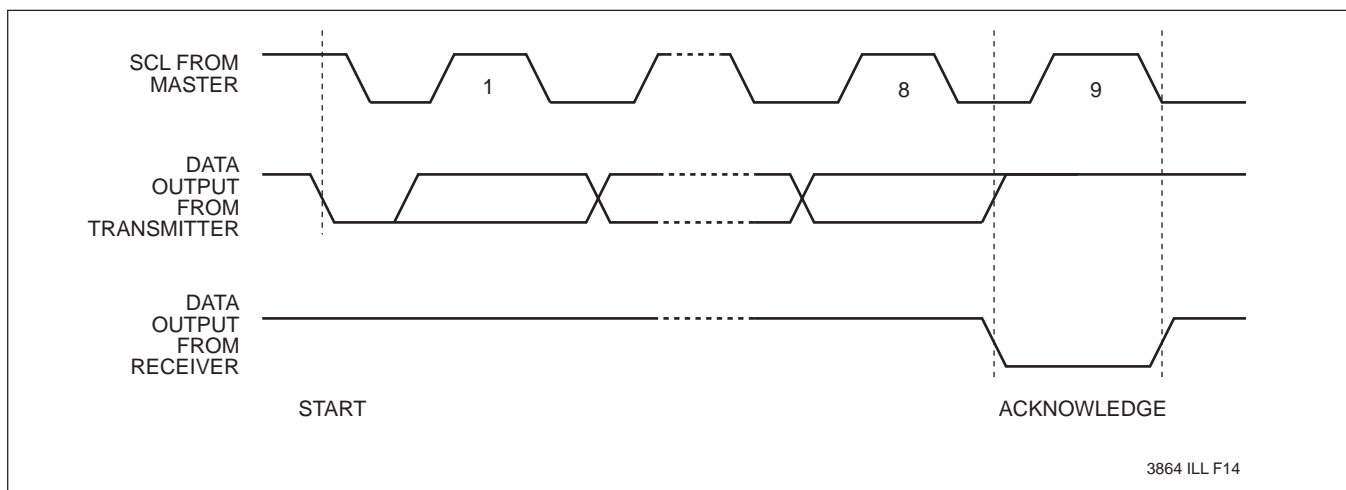

3864 ILL F14

X9241

DETAILED OPERATION

All four E²POT potentiometers share the serial interface and share a common architecture. Each potentiometer is comprised of a resistor array, a wiper counter register and four data registers. A detailed discussion of the register organization and array operation follows.

Wiper Counter Register

The X9241 contains four wiper counter registers (WCR), one for each E²POT potentiometer. The WCR can be envisioned as a 6-bit parallel and serial load counter with its outputs decoded to select one of sixty-four switches along its resistor array. The contents of the WCR can be altered in four ways: it may be written directly by the host via the Write WCR instruction (serial load); it may be written indirectly by transferring the contents of one of four associated data registers via the XFR Data Register instruction (parallel load); it can be modified one step at a time by the Increment/ Decrement instruction; finally, it is loaded with the contents of its data register zero (R0) upon power-up.

The WCR is a volatile register; that is, its contents are lost when the X9241 is powered-down. Although the register is automatically loaded with the value in R0 upon power-up, it should be noted this may be different from the value present at power-down.

Data Registers

Each potentiometer has four nonvolatile data registers. These can be read or written directly by the host and data can be transferred between any of the four data registers and the WCR. It should be noted all operations changing data in one of these registers is a nonvolatile operation and will take a maximum of 10ms.

If the application does not require storage of multiple settings for the potentiometer, these registers can be used as regular memory locations that could possibly store system parameters or user preference data.

Figure 8. Detailed Potentiometer Block Diagram

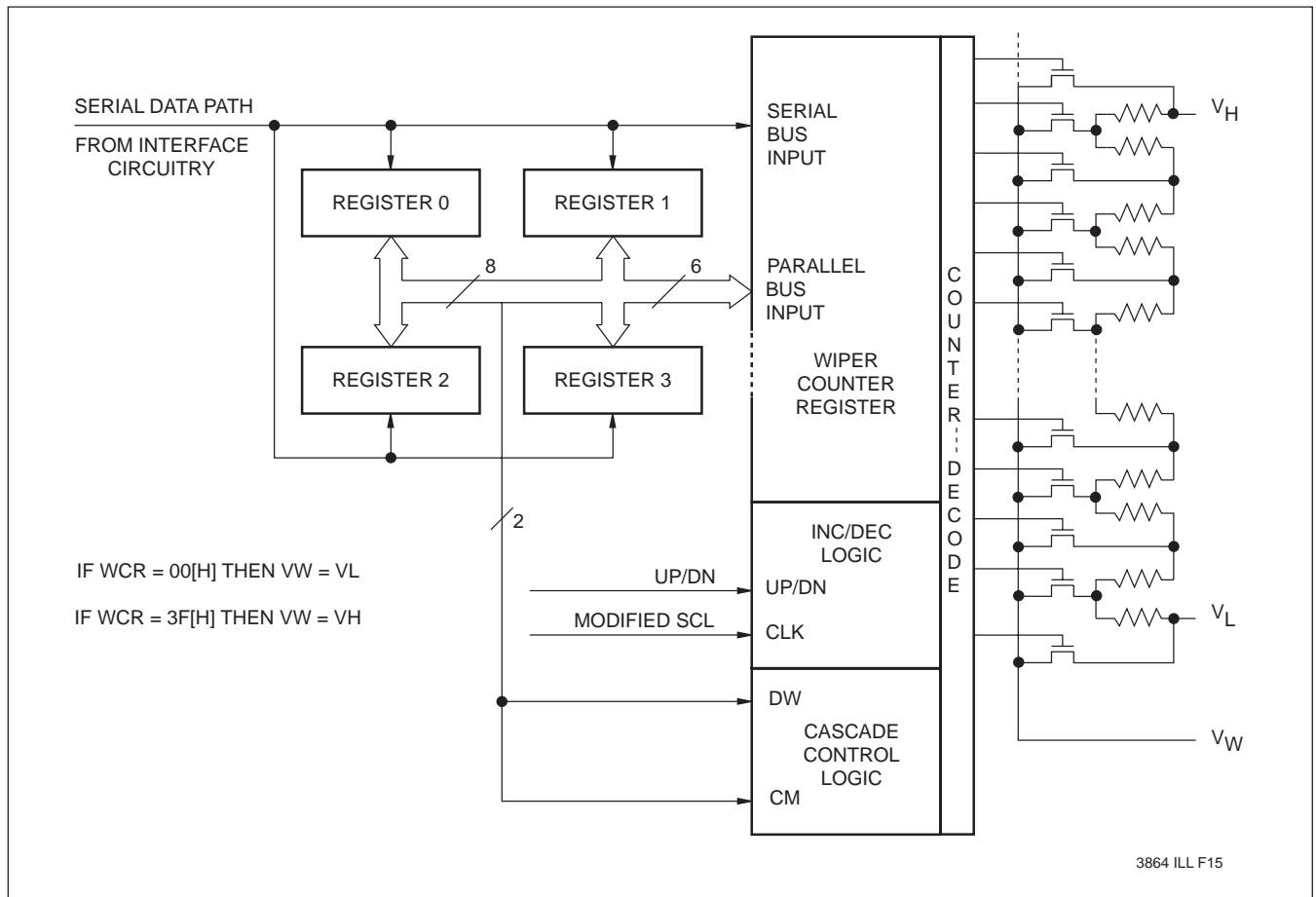

X9241

Cascade Mode

The X9241 provides a mechanism for cascading the arrays. That is, the sixty-three resistor elements of one array may be cascaded (linked) with the resistor elements of an adjacent array.

Cascade Control Bits

The data byte, for the three-byte commands, contains 6 bits (LSBs) for defining the wiper position plus two high order bits, CM (Cascade Mode) and DW (Disable Wiper).

The state of CM enables or disables (normal operation) cascade mode. When the CM bit of the WCR is set to "0" the potentiometer is in the normal operation mode. When the CM bit of the WCR is set to "1" the potentiometer is cascaded with its adjacent higher order potentiometer. For example; if bit 7 of WCR2 is set to "1", pot 2 will be cascaded to pot 3.

The state of DW enables or disables the wiper. When the

DW bit of the WCR is set to "0" the wiper is enabled; when set to "1" the wiper is disabled. If the wiper is disabled, the wiper terminal will be electrically isolated and float.

When operating in cascade mode VH, VL and the wiper terminals of the cascaded arrays must be electrically connected externally. All but one of the wipers must be disabled. The user can alter the wiper position by writing directly to the WCR or indirectly by transferring the contents of the data registers to the WCR or by using the Increment/Decrement command.

When using the Increment/Decrement command the wiper position will automatically transition between arrays. The current position of the wiper can be determined by reading the WCR registers; if the DW bit is "0", the wiper in that array is active. If the current wiper position is to be maintained, a global XFR WCR to Data Register command must be issued before power-down.

Figure 9. Cascading Arrays

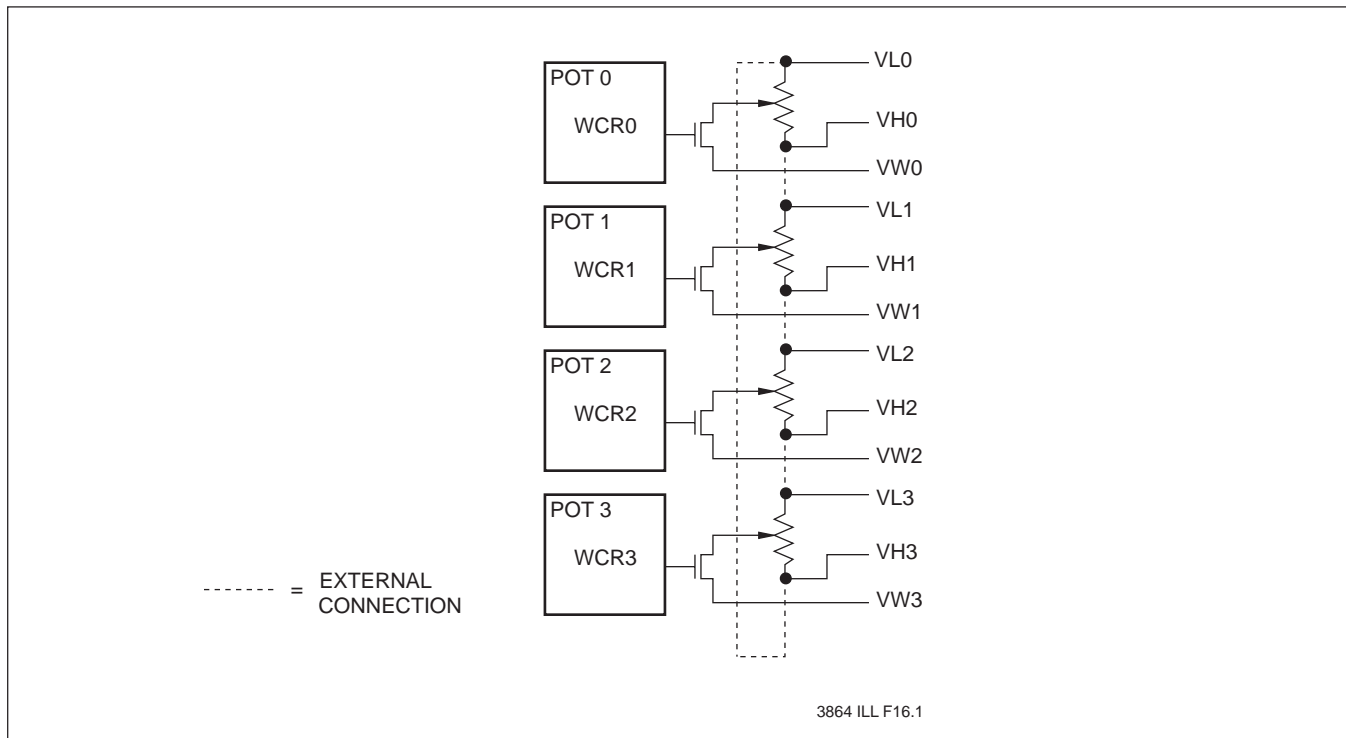

X9241

ABSOLUTE MAXIMUM RATINGS*

Temperature under Bias -65°C to +135°C
 Storage Temperature -65°C to +150°C
 Voltage on SCK, SCL or any Address Input
 with Respect to V_{SS} -1V to +7V
 Voltage on any V_H or V_L Referenced to V_{SS} $\pm 8V$
 $\Delta V = |V_H - V_L|$ 16V
 Lead Temperature (Soldering, 10 seconds) 300°C

*COMMENT

Stresses above those listed under “Absolute Maximum Ratings” may cause permanent damage to the device. This is a stress rating only and the functional operation of the device at these or any other conditions above those indicated in the operational sections of this specification is not implied. Exposure to absolute maximum rating conditions for extended periods may affect device reliability.

RECOMMENDED OPERATING CONDITIONS

Temperature	Min.	Max.
Commercial	0°C	+70°C
Industrial	-40°C	+85°C
Military	-55°C	+125°C

Supply Voltage	Limits
X9241	5V $\pm 10\%$

3864 PGM T04.1

3864 PGM T03

ANALOG CHARACTERISTICS (Over recommended operating conditions unless otherwise stated.)

Symbol	Parameter	Limits				Test Conditions
		Min.	Typ.	Max.	Units	
R_{TOTAL}	End to End Resistance	-20		+20	%	
	Power Rating			50	mW	25°C, each pot
I_W	Wiper Current	-1		+1	mA	
R_W	Wiper Resistance		40	100	Ω	Wiper Current = ± 1 mA
V_{TERM}	Voltage on any V_H or or V_L Pin	-5		+5	V	
	Noise		≤ 120		dB/ \sqrt{Hz}	Ref: 1V
	Resolution (4)		1.6	0.4	%	
	Absolute Linearity (1)	-1		+1	MI(3)	$V_{w(n)(actual)} - V_{w(n)(expected)}$
	Relative Linearity (2)	-0.2		+0.2	MI(3)	$V_{w(n+1)} - [V_{w(n)} + MI]$
	Temperature Coefficient		± 300		ppm/°C	

3864 PGM T05.2

D.C. OPERATING CHARACTERISTICS (Over recommended operating conditions unless otherwise stated.)

Symbol	Parameter	Limits				Test Conditions
		Min.	Typ.	Max.	Units	
I_{CC}	Supply Current (Active)			3	mA	$f_{SCL} = 100KHz$, SDA = Open, Other Inputs = V_{SS}
I_{SB}	V_{CC} Current (Standby)		200	500	μA	SCL=SDA= V_{CC} , Addr. = V_{SS}
I_{LI}	Input Leakage Current			10	μA	$V_{IN} = V_{SS}$ to V_{CC}
I_{LO}	Output Leakage Current			10	μA	$V_{OUT} = V_{SS}$ to V_{CC}
V_{IH}	Input HIGH Voltage	2		$V_{CC} + 1$	V	
V_{IL}	Input LOW Voltage	-1		0.8	V	
V_{OL}	Output LOW Voltage			0.4	V	$I_{OL} = 3mA$

3864 PGM T06.3

- Notes:** (1) Absolute Linearity is utilized to determine actual wiper voltage versus expected voltage as determined by wiper position when used as a potentiometer.
 (2) Relative Linearity is utilized to determine the actual change in voltage between two successive tap positions when used as a potentiometer. It is a measure of the error in step size.
 (3) $MI = RTOT/63$ or $(V_H - V_L)/63$, single pot
 (4) Max. = all four arrays cascaded together, Typical = individual array resolutions.

X9241

ENDURANCE AND DATA RETENTION

Parameter	Min.	Units
Minimum Endurance	100,000	Data Changes per Register
Data Retention	100	Years

3864 PGM T07.2

CAPACITANCE

Symbol	Parameter	Max.	Units	Test Conditions
$C_{I/O}^{(5)}$	Input/Output Capacitance (SDA)	8	pF	$V_{I/O} = 0V$
$C_{IN}^{(5)}$	Input Capacitance (A0, A1, A2, A3 and SCL)	6	pF	$V_{IN} = 0V$

3864 PGM T08

POWER-UP TIMING

Symbol	Parameter	Max.	Units
$t_{PUR}^{(6)}$	Power-up to Initiation of Read Operation	1	ms
$t_{PUW}^{(6)}$	Power-up to Initiation of Write Operation	5	ms

3864 PGM T09

A.C. CONDITIONS OF TEST

Input Pulse Levels	$V_{CC} \times 0.1$ to $V_{CC} \times 0.9$
Input Rise and Fall Times	10ns
Input and Output Timing Levels	$V_{CC} \times 0.5$

3864 PGM T10

Notes: (5) This parameter is periodically sampled and not 100% tested.

- (6) t_{PUR} and t_{PUW} are the delays required from the time V_{CC} is stable until the specified operation can be initiated. These parameters are periodically sampled and not 100% tested.

EQUIVALENT A.C. TEST CIRCUIT

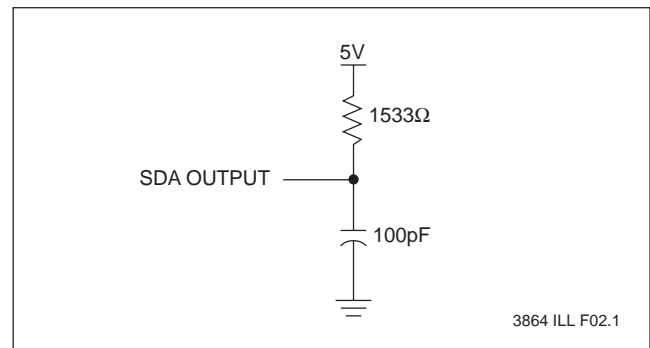

3864 ILL F02.1

SYMBOL TABLE

WAVEFORM	INPUTS	OUTPUTS
	Must be steady	Will be steady
	May change from LOW to HIGH	Will change from LOW to HIGH
	May change from HIGH to LOW	Will change from HIGH to LOW
	Don't Care: Changes Allowed	Changing: State Not Known
	N/A	Center Line is High Impedance

Guidelines for Calculating Typical Values of Bus Pull-Up Resistors

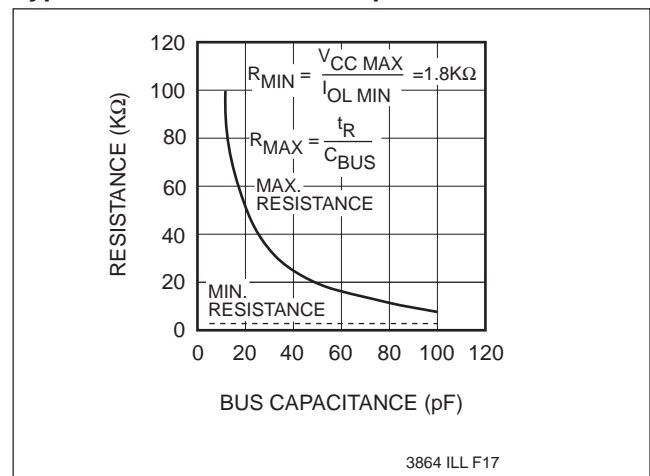

3864 ILL F17

X9241

A.C. CHARACTERISTICS (Over recommended operating conditions unless otherwise stated)

Symbol	Parameter	Limits		Units	Reference Figure
		Min.	Max.		
f_{SCL}	SCL Clock Frequency	0	100	KHz	10
t_{LOW}	Clock LOW Period	4700		ns	10
t_{HIGH}	Clock HIGH Period	4000		ns	10
t_R	SCL and SDA Rise Time		1000	ns	10
t_F	SCL and SDA Fall Time		300	ns	10
T_i	Noise Suppression Time Constant (Glitch Filter)		100	ns	10
$t_{SU:STA}$	Start Condition Setup Time (for a Repeated Start Condition)	4700		ns	10 & 12
$t_{HD:STA}$	Start Condition Hold Time	4000		ns	10 & 12
$t_{SU:DAT}$	Data in Setup Time	250		ns	10
$t_{HD:DAT}$	Data in Hold Time	0		ns	10
t_{AA}	SCL LOW to SDA Data Out Valid	300	3500	ns	11
t_{DH}	Data Out Hold Time	300		ns	11
$t_{SU:STO}$	Stop Condition Setup Time	4700		ns	10 & 12
t_{BUF}	Bus Free Time Prior to New Transmission	4700		ns	10
t_{WR}	Write Cycle Time (Nonvolatile Write Operation)		10	ms	13
t_{STPWV}	Wiper Response Time From Stop Generation		500	μ s	13
t_{CLWV}	Wiper Response From SCL LOW		1000	μ s	6
$t_R V_{CC}$	V_{CC} Power-up Rate	0.2	50	mV/ μ s	

3864 PGM T11.3

Figure 10. Input Bus Timing

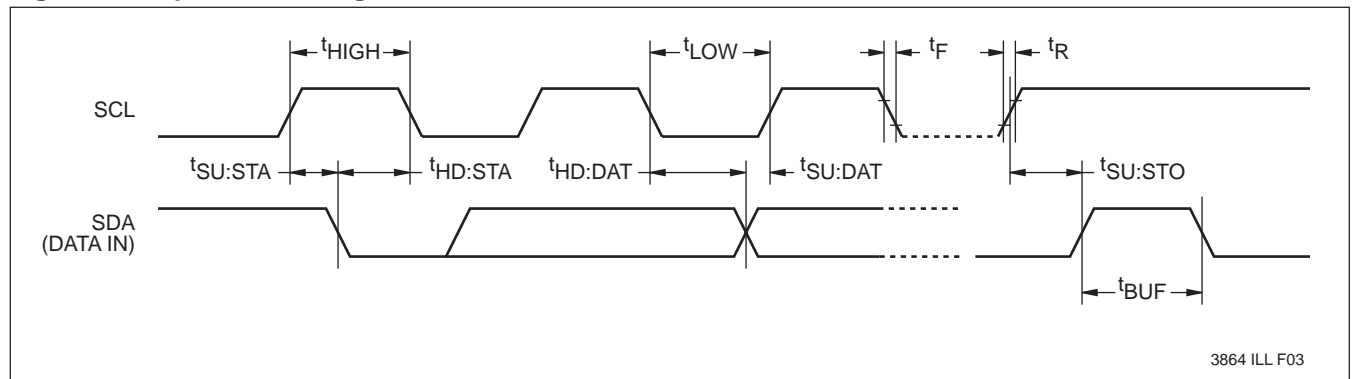

3864 ILL F03

Figure 11. Output Bus Timing

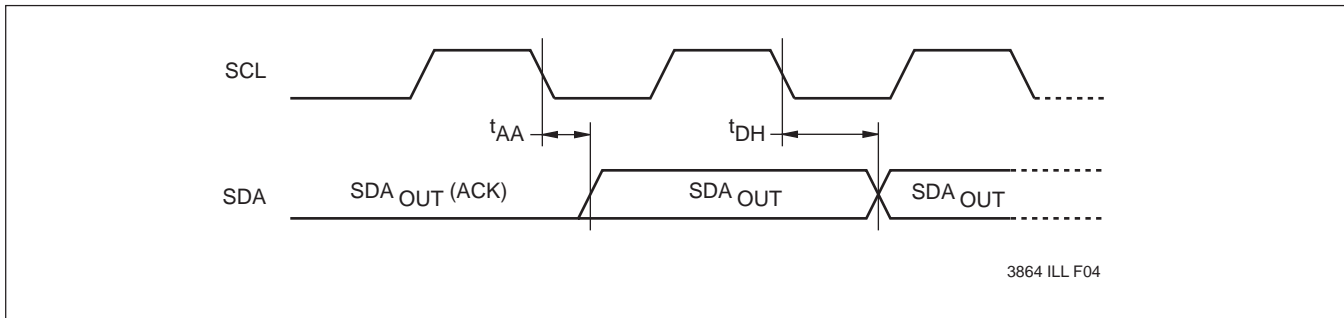

Figure 12. Start Stop Timing

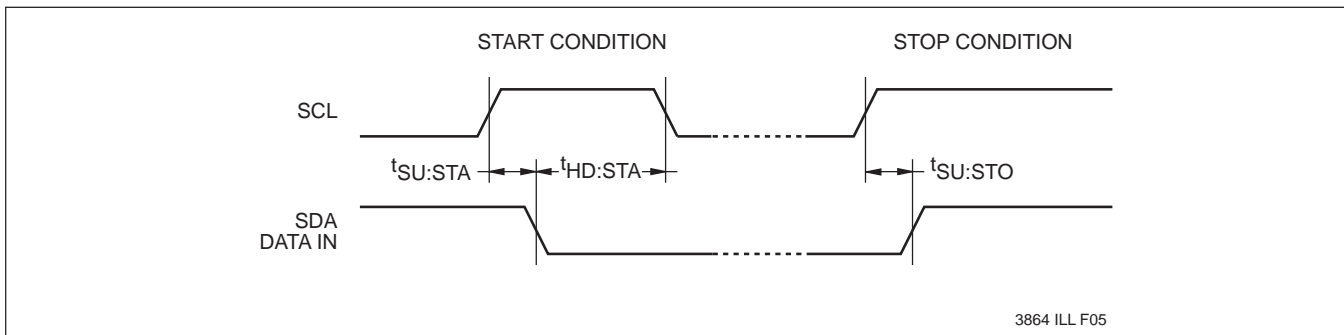
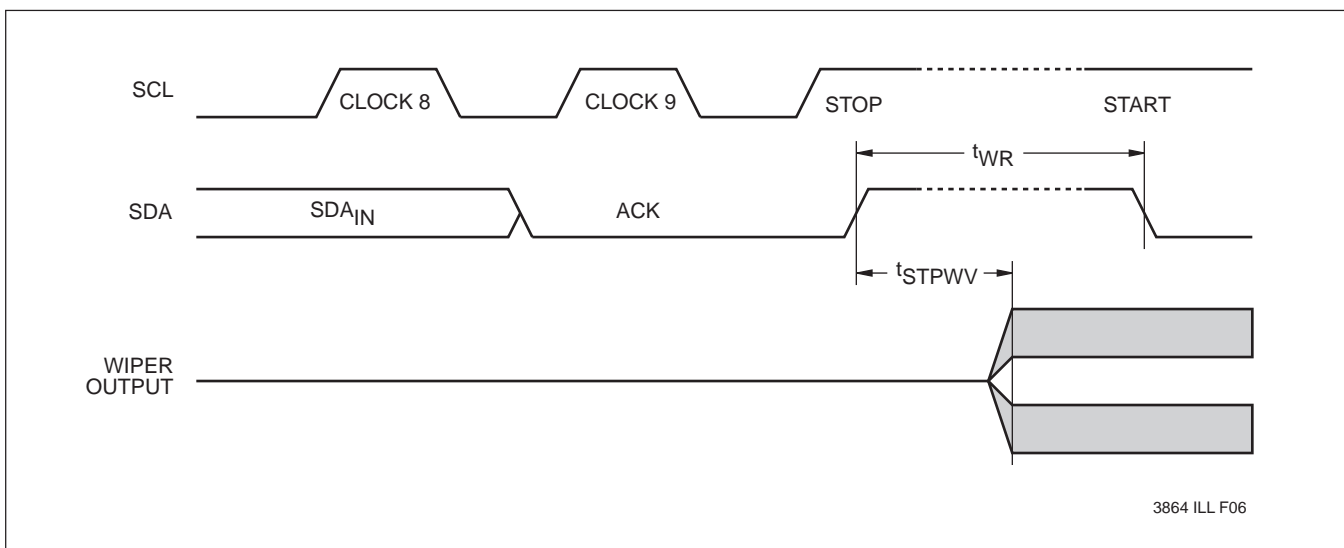

Figure 13. Write Cycle and Wiper Response Timing



X9241

PACKAGING INFORMATION

20-LEAD PLASTIC DUAL IN-LINE PACKAGE TYPE P

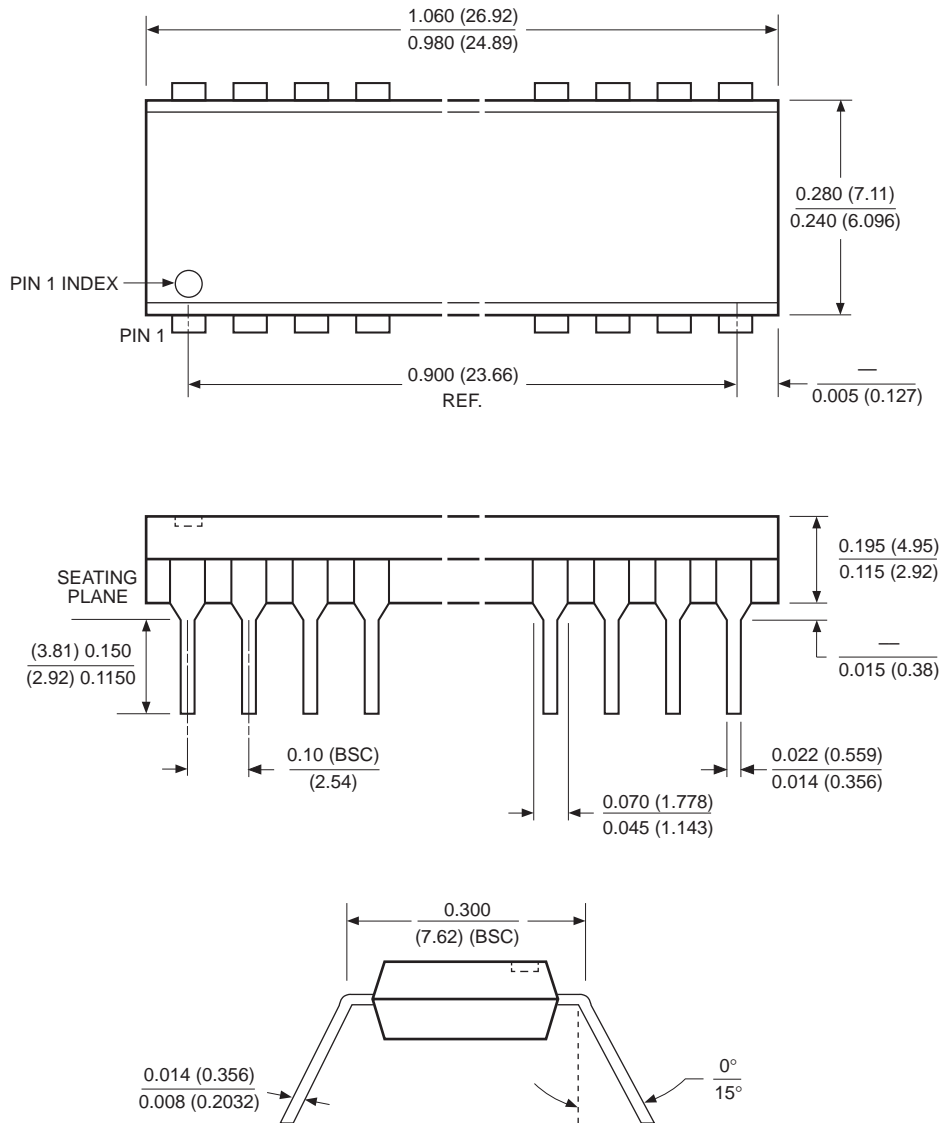

NOTE:

1. ALL DIMENSIONS IN INCHES (IN PARENTHESES IN MILLIMETERS)
2. PACKAGE DIMENSIONS EXCLUDE MOLDING FLASH

3926 FHD F18.1

X9241

PACKAGING INFORMATION

20-LEAD PLASTIC SMALL OUTLINE GULL WING PACKAGE TYPE S

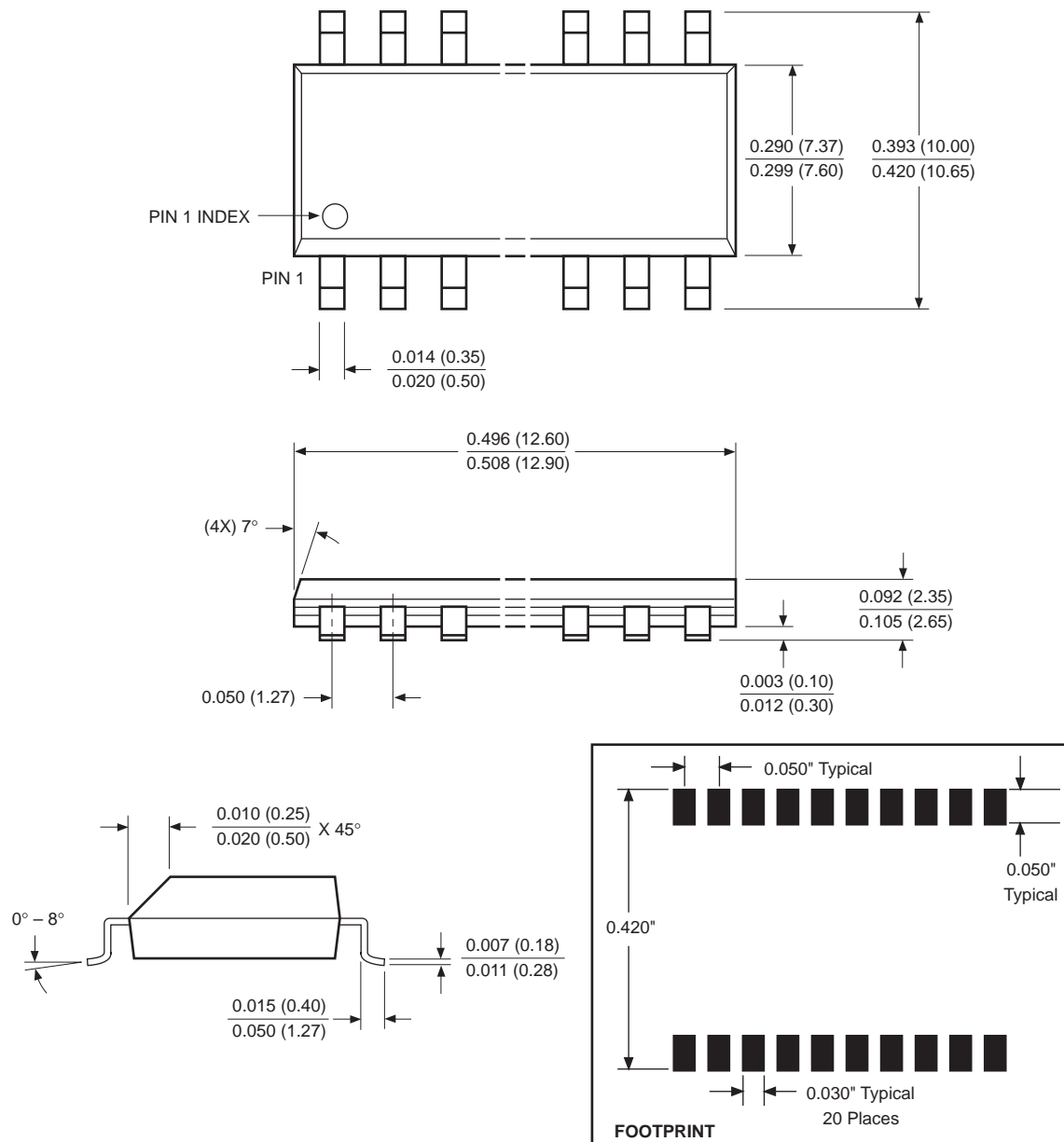

NOTE: ALL DIMENSIONS IN INCHES (IN PARENTHESES IN MILLIMETERS)

3926 FHD F23

X9241

PACKAGING INFORMATION

20-LEAD PLASTIC, TSSOP PACKAGE TYPE V

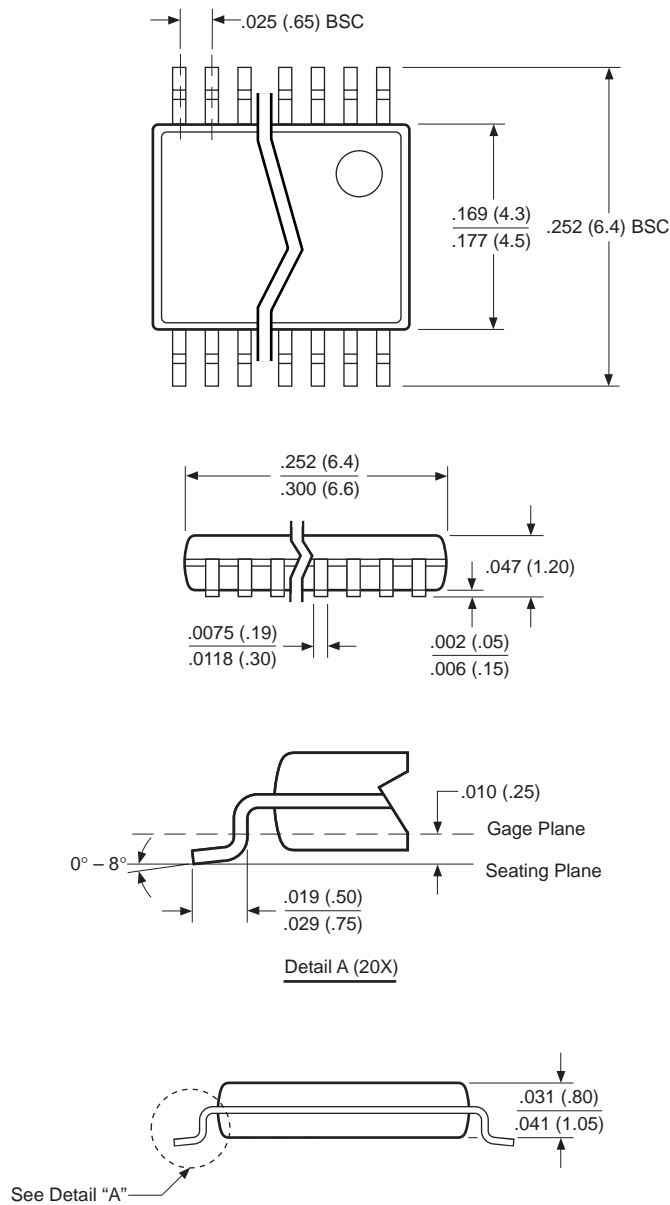

NOTE: ALL DIMENSIONS IN INCHES (IN PARENTHESES IN MILLIMETERS)

X9241

ORDERING INFORMATION

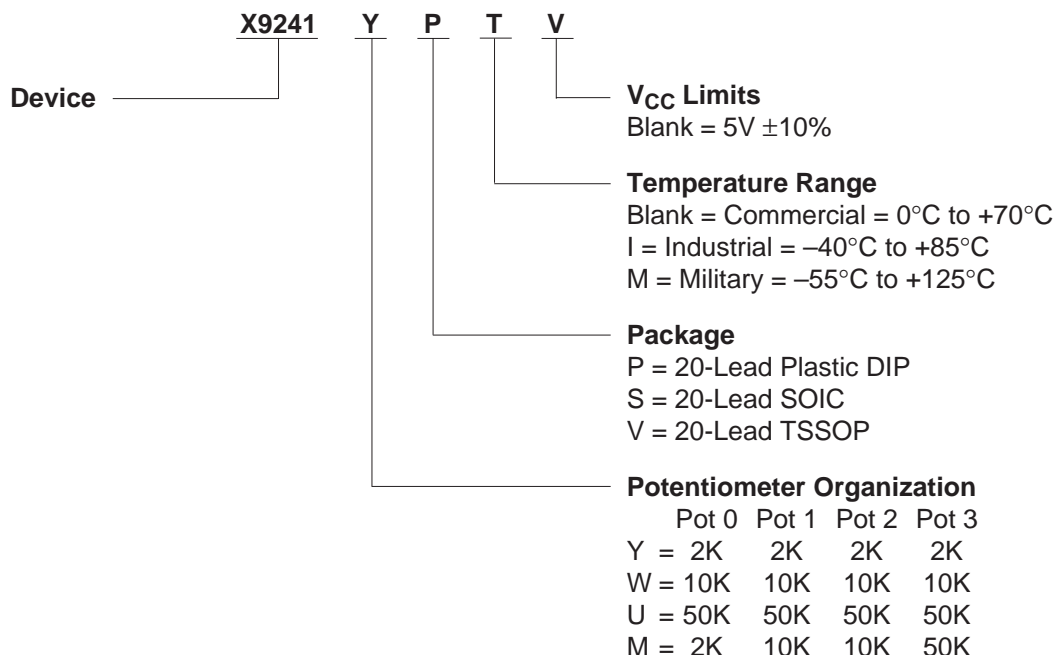

LIMITED WARRANTY

Devices sold by Xicor, Inc. are covered by the warranty and patent indemnification provisions appearing in its Terms of Sale only. Xicor, Inc. makes no warranty, express, statutory, implied, or by description regarding the information set forth herein or regarding the freedom of the described devices from patent infringement. Xicor, Inc. makes no warranty of merchantability or fitness for any purpose. Xicor, Inc. reserves the right to discontinue production and change specifications and prices at any time and without notice.

Xicor, Inc. assumes no responsibility for the use of any circuitry other than circuitry embodied in a Xicor, Inc. product. No other circuits, patents, licenses are implied.

U.S. PATENTS

Xicor products are covered by one or more of the following U.S. Patents: 4,263,664; 4,274,012; 4,300,212; 4,314,265; 4,326,134; 4,393,481; 4,404,475; 4,450,402; 4,486,769; 4,488,060; 4,520,461; 4,533,846; 4,599,706; 4,617,652; 4,668,932; 4,752,912; 4,829,482; 4,874,967; 4,883,976. Foreign patents and additional patents pending.

LIFE RELATED POLICY

In situations where semiconductor component failure may endanger life, system designers using this product should design the system with appropriate error detection and correction, redundancy and back-up features to prevent such an occurrence.

Xicor's products are not authorized for use in critical components in life support devices or systems.

1. Life support devices or systems are devices or systems which, (a) are intended for surgical implant into the body, or (b) support or sustain life, and whose failure to perform, when properly used in accordance with instructions for use provided in the labeling, can be reasonably expected to result in a significant injury to the user.
2. A critical component is any component of a life support device or system whose failure to perform can be reasonably expected to cause the failure of the life support device or system, or to affect its safety or effectiveness.