

DUAL OPERATIONAL AMPLIFIER WITH SWITCH

■ GENERAL DESCRIPTION

The NJM2123 is a operational amplifier with analog switch (2 circuit of 2-input/1-output). It is applicable to the audio part for Video (VTR,LD...) and the Car-stereo.

The NJM2123 has the same electrical characteristic of the NJM2112,and is low saturation output type.

The mode of switch is improved from the current control type (NJM2120:1 circuit of 2-input/1-output) to the voltage control type.So,it is easy to use.

■ PACKAGE OUTLINE

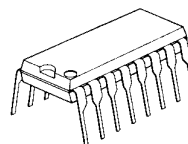

NJM2123D

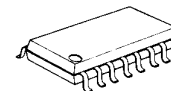

NJM2123M



NJM2123V

■ FEATURES

- Single Supply
- Operating Voltage (+4V~+20V)
- Slew Rate (3V/μs typ.)
- Analog Switch Function
- Wide Unity Gain Bandwidth (10MHz typ.)
- Package Outline DIP16,DMP16,SSOP16
- Bipolar Technology

■ PIN CONFIGURATION

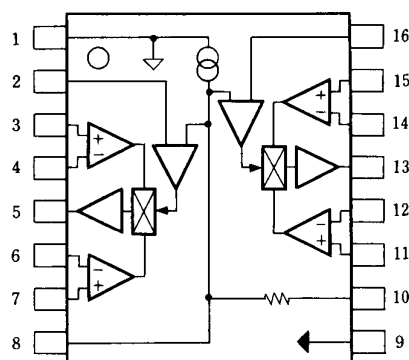

NJM2123D
NJM2123M
NJM2123V

PIN FUNCTION

1.V ⁺	9.GND
2.SW1	10.SW R
3.IN1 A +INPUT	11.IN2 B +INPUT
4.IN1 A -INPUT	12.IN2 B -INPUT
5.OUT1	13.OUT2
6.IN1 B -INPUT	14.IN2 A -INPUT
7.IN1 B +INPUT	15.IN2 A +INPUT
8.SW C	16.SW2

■ EQUIVALENT CIRCUIT

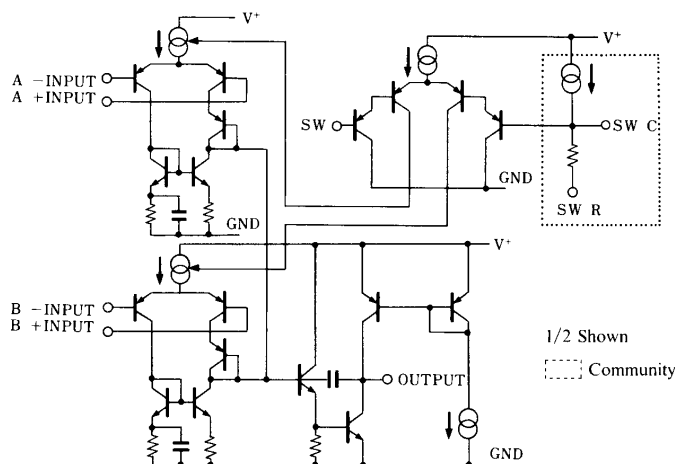

1/2 Shown
Community

NJM2123

■ ABSOLUTE MAXIMUM RATINGS

(Ta=25°C)

PARAMETER	SYMBOL	RATINGS	UNIT
Supply Voltage	V^+	20 (± 10)	V
Differential Input Voltage	V_{ID}	± 14	V
Input Voltage	V_{IC}	20(±10)note:Less than V^+ (note)	V
Control Voltage	V_{CTR}	20(±10)note:Less than V^+	V
Power Dissipation	P_D	(DIP8) 700 (DMP8) 300 (SSOP8) 300	mW
Operating Temperature Range	T_{opr}	-30~+85	°C
Storage Temperature Range	T_{stg}	-40~+125	°C

■ ELECTRICAL CHARACTERISTICS

($V^+=5V, Ta=25^\circ C$)

PARAMETER	SYMBOL	TEST CONDITION	MIN.	TYP.	MAX.	UNIT
Operating Current	I_{CC}	$V_{IN}=2.5V, R_L=\infty$	-	6.0	8.0	mA
Input Offset Voltage	V_{IO}	$R_S \leq 10k\Omega$	-	1.0	6.0	mV
Input Offset Current	I_{IO}		-	10	200	nA
Input Bias Current	I_B		-	100	300	nA
Large Signal Voltage Gain	A_V	$R_L \geq 10k\Omega$	60	80	-	dB
Maximum Output Voltage Swing 1	V_{OM1}	$V^+V = \pm 2.5V, R_L \geq 2k\Omega$	± 2.0	± 2.2	-	V
Maximum Output Voltage Swing 2	V_{OM2}	$V^+V = \pm 2.5V, R_L \geq 10k\Omega$	± 2.3	± 2.4	-	V
Input Common Mode Voltage Range	V_{ICM}		1.5	-	4.0	V
Common Mode Rejection Ratio	CMR		60	74	-	dB
Supply Voltage Rejection Ratio	SVR		60	80	-	dB
Slew Rate	SR	$A_V=1, V_{IN}=2V \sim 3V$	-	3	-	V/ μs
Gain Bandwidth Product	GB		-	10	-	MHz
Crosstalk	CT	$f=1kHz$	-	90	-	dB
Channel Separation	CS	$f=1kHz$	-	120	-	dB
Switch Threshold Voltage	V_{th}	Internal V_{th}	2.0	2.5	3.0	V

(note1) Applied circuit voltage gain is desired to be operated within the range of 3dB to 30 dB.

(note2) Special care being required for input common mode voltage range and the oscillation due to the capacitive load when operating on voltage follower.

(note3) "Crosstalk" is defined about leak of signal on the same circuit.

(note4) "Channel Separation" is defined about leak of signal between 2 circuits.

(note5) V_{th} is possible to adjust by external parts.

(note6) Voltage for V-PIN has to be supplied earlier than V^+ -PIN in case of two supply voltage.

■ TYPICAL CHARACTERISTICS

In case of single supply voltage ($V^+=5V$)

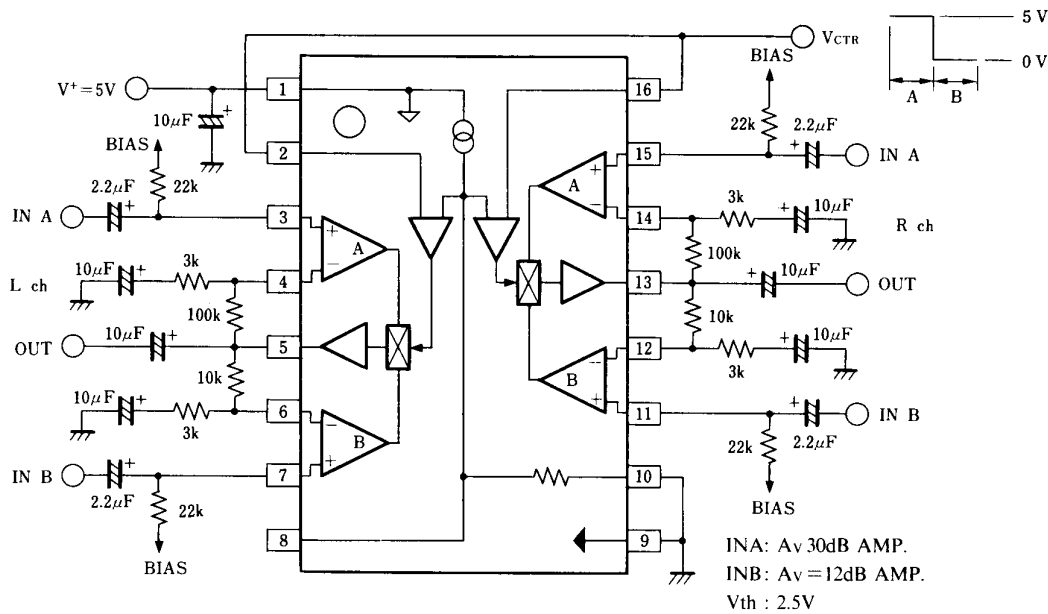

■ SWITCHING MECHANISM

- in case of single supply voltage

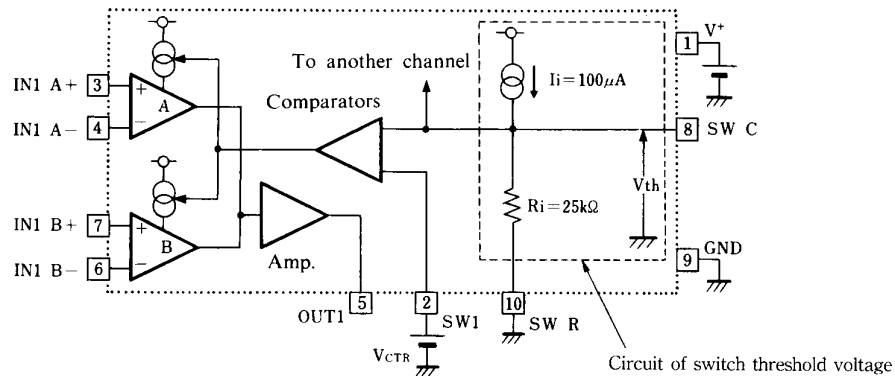

The switch circuit of NJM2123 consist of comparators for switch and circuit for switch threshold voltage (V_{th}) due to establish threshold of comparator. $V_{th} = I_i \times R_i = 2.5V$ in case of above Figure.

Comparator selects INPUT (A or B) by compare of control voltage (V_{CTR}) and threshold voltage (V_{th}) and control of operating current of Amp (INPUT).

INPUT A is selected in case of $V_{CTR} > V_{th}$ and INPUT B is selected in case of $V_{CTR} < V_{th}$.

V_{CTR} can not be used between $V_{th} \pm 0.1V$ in order that signal of both INPUT A and INPUT B are mixed in case that V_{CTR} is near V_{th} .

NJM2123

■ ABOUT ADJUSTMENT OF V_{th}

The switch threshold voltage (V_{th}) is possible to adjust by external parts to SW C/SW R.It needs to be satisfy with condition of $V_{th} \leq V^+ - 2V$.

This reason is caused by equivalent circuit of comparator for switch.

The V_{th} has to be adjust in case that supply voltage is less than 5V (±2.5V).

Adjustment method is as following.

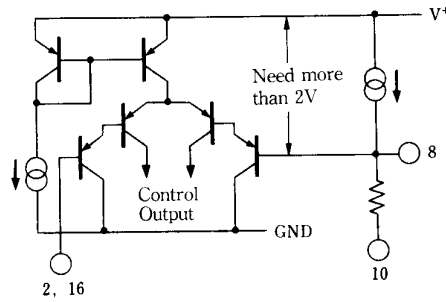

■ ADJUSTMENT OF V_{th}

In case of $I_i = 100\mu A, R_i = 25k\Omega, R_e$ (External Resistor)

● Internal V_{th} (Single supply)

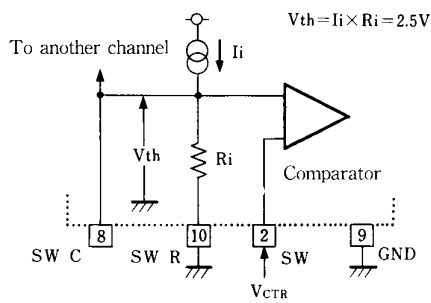

● Internal V_{th} (Two supply)

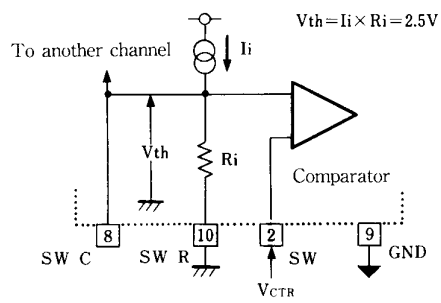

● V_{th} 2.5V (Single supply)

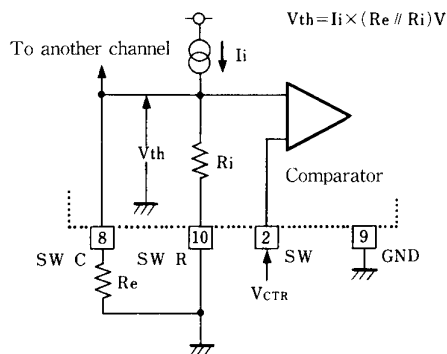

● V_{th} > 2.5V (Single supply)

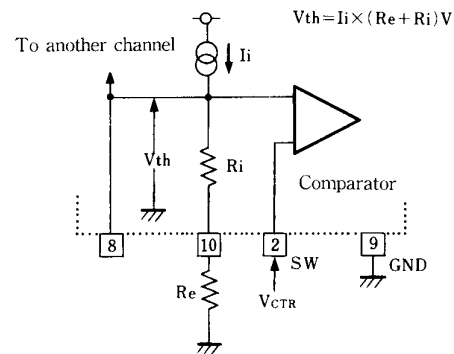

■ TYPICAL CHARACTERISTICS

Operating Current vs. Operating Voltage

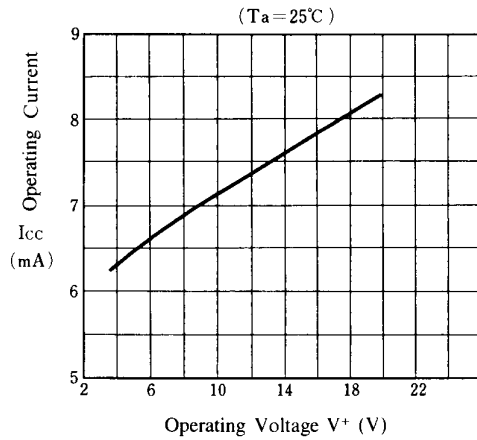

Input Offset Voltage vs. Operating Voltage

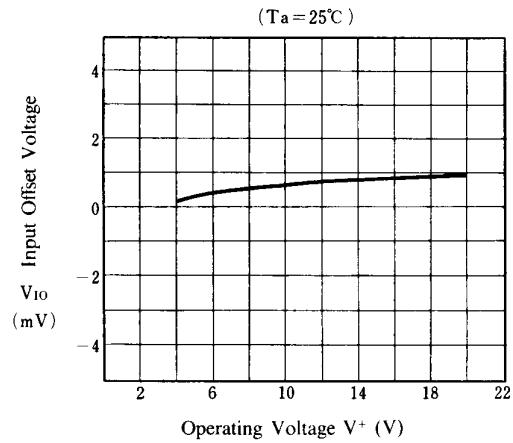

Input Bias Current vs. Operating Voltage

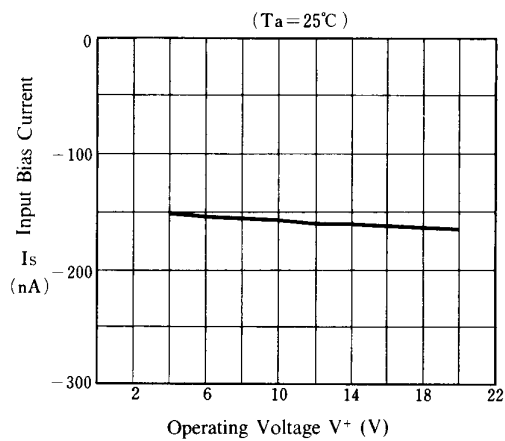

Switch Threshold Voltage vs. Operating Voltage

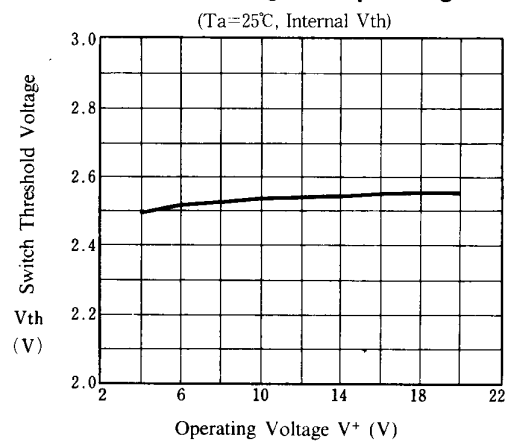

Supply Voltage Rejection Ratio vs. Operating Voltage

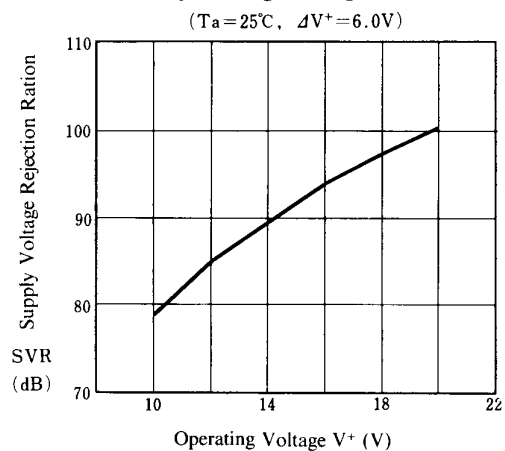

Maximum Output Voltage vs. Load Resistance

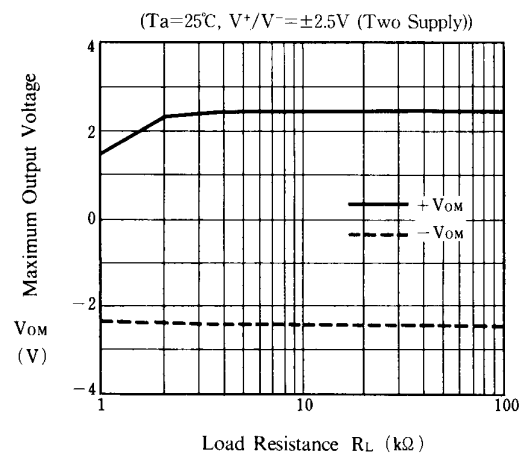

■ TYPICAL CHARACTERISTICS

Maximum Output Voltage vs. Operating Voltage

($T_a = 25^\circ\text{C}$, $R_L = 2\text{ k}\Omega$)

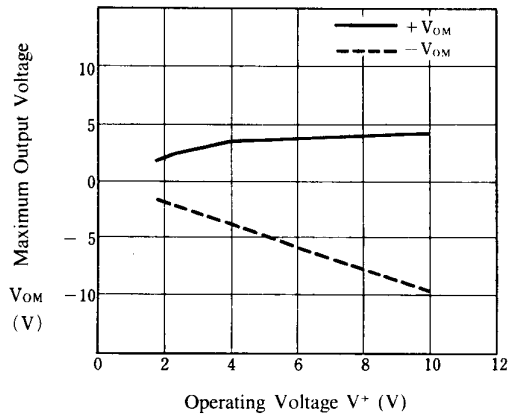

Maximum Output Voltage vs. Operating Voltage

($T_a = 25^\circ\text{C}$, $R_L = 10\text{ k}\Omega$)

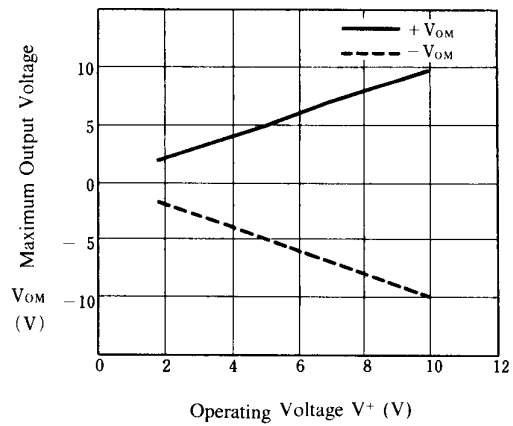

Output Source Current

($T_a = 25^\circ\text{C}$, $V^+ = 5.0\text{ V}$)

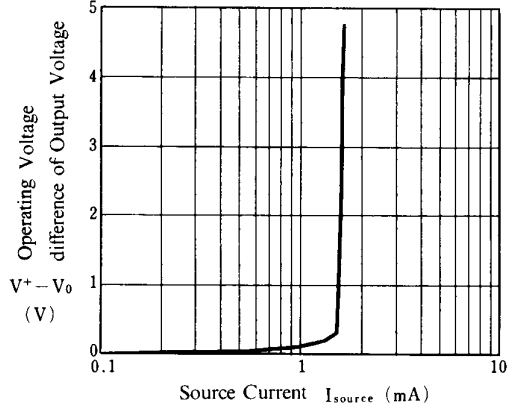

Test Circuit (Output Source Current)

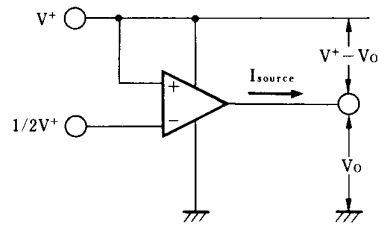

Output Voltage vs. Output Sink Current

($T_a = 25^\circ\text{C}$, $V^+ = 5.0\text{ V}$)

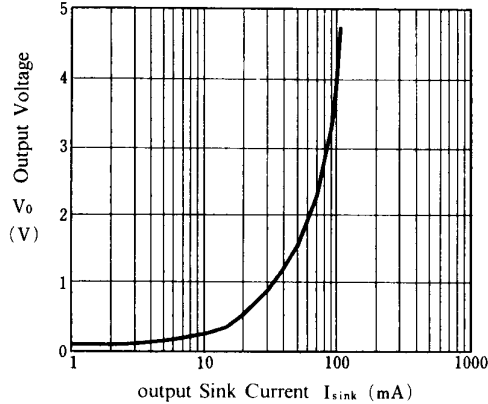

Test Circuit (Output Sink Current)

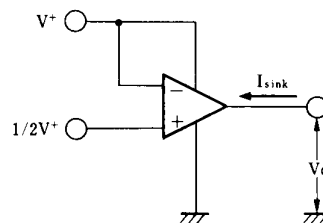

■ TYPICAL CHARACTERISTICS

Voltage Gain vs. Frequency

($T_a=25^\circ\text{C}$, $V^+=5.0\text{V}$)

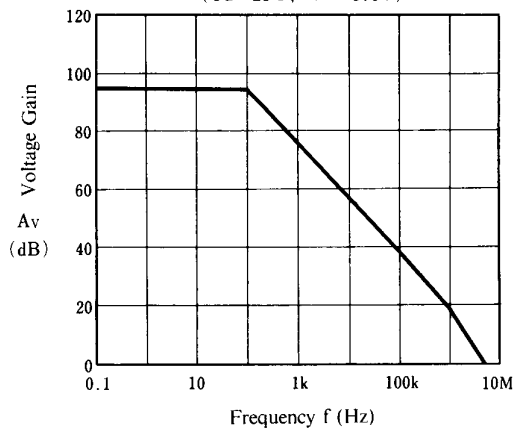

Channel Separation vs. Frequency

($T_a=25^\circ\text{C}$, $V^+=5.0\text{V}$)

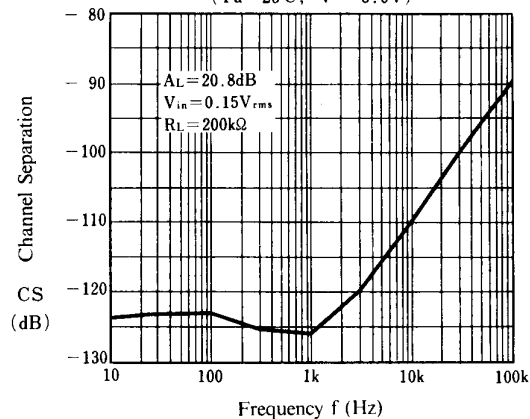

Total Harmonic Distortion vs. Output Voltage

($T_a=25^\circ\text{C}$, $V^+=5.0\text{V}$)

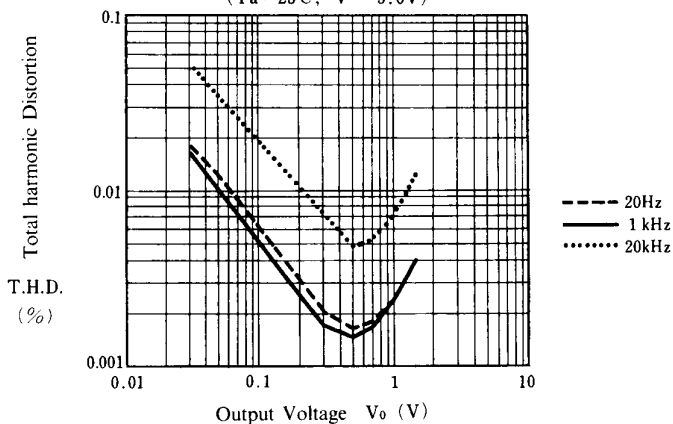

Test Circuit (Voltage Gain/Phase)

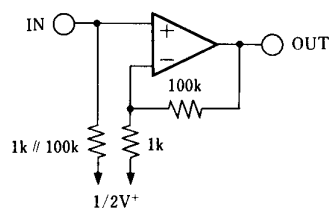

Voltage Gain/Phase vs. Frequency

($T_a=25^\circ\text{C}$, $V^+=5.0\text{V}$)

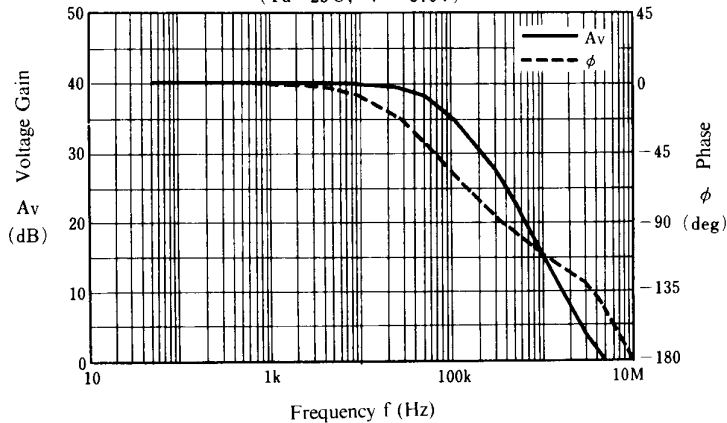

Test Circuit (THD)

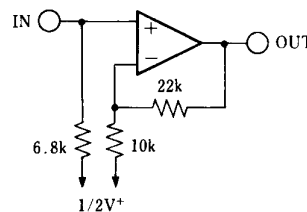

TYPICAL CHARACTERISTICS

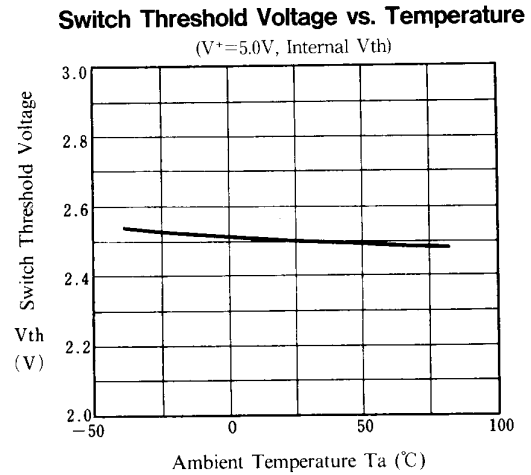
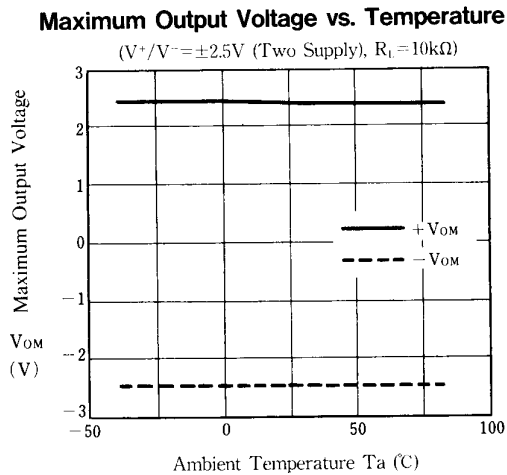
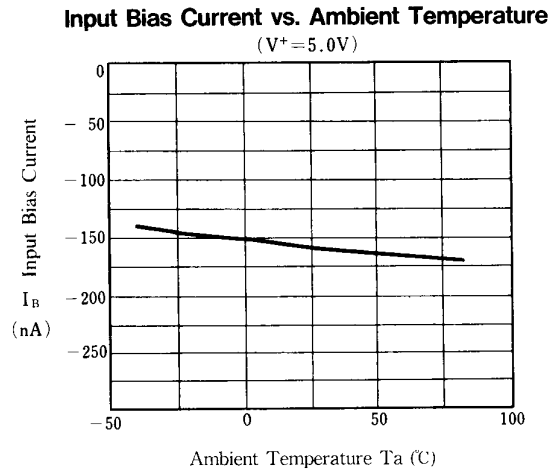
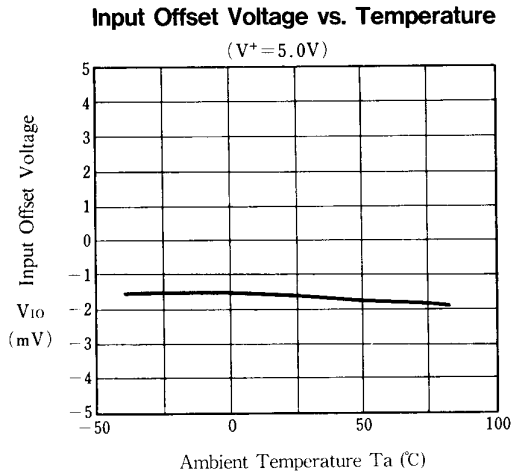
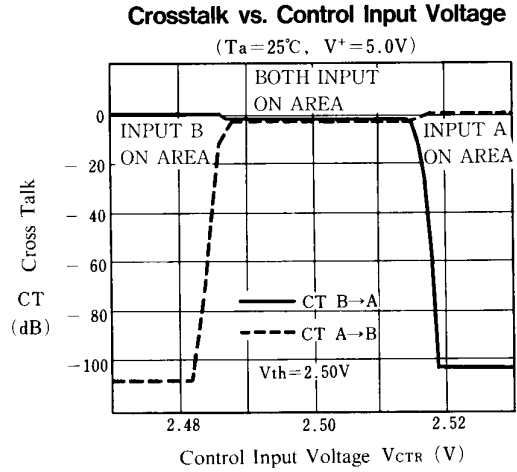
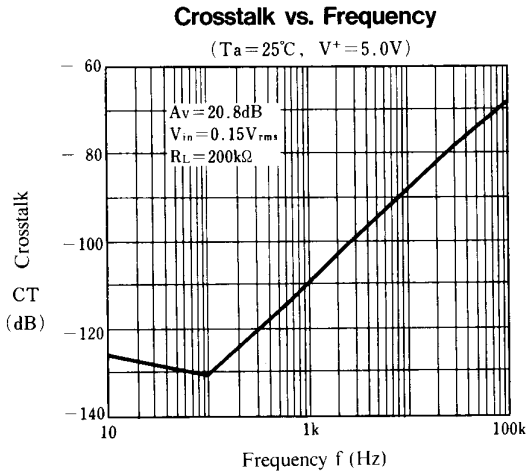

[CAUTION]

The specifications on this databook are only given for information, without any guarantee as regards either mistakes or omissions. The application circuits in this databook are described only to show representative usages of the product and not intended for the guarantee or permission of any right including the industrial rights.