

KA2822D

3-Phase BLDC Motor Driver

Features

- 3-phase, full-wave, linear BLDC motor driver with 2 hall sensors
- Built-in soft switching drive circuit
- 300 or 360 RPM speed control
- Snubberless
- Built-in chip enable function
- Built-in digital speed control circuit
- Built-in current limit circuit
- Index sensorless
- Built-in TSD (Thermal shutdown)
- Low saturation voltage
- Digital input: TTL, 5V CMOS compatible
- Built-in current-mode control circuit (I_{PEAK}: 1A)

Description

The KA2822D is a monolithic integrated circuit, and suitable for the three-phase spindle motor driver of FDD system.



Typical Application

- 3.5-inch floppy disk drive (FDD) spindle motor
- Other 3-phase BLDC motor

Ordering Information

Device	Package	Operating Temp.
KA2822D	28-SSOPH-375	0 ~ 75°C
KA2822DTF	28-SSOPH-375	0 ~ 75°C
KA2822BD	28-SSOPH-375	0 ~ 75°C
KA2822BDTF	28-SSOPH-375	0 ~ 75°C

Pin Assignments

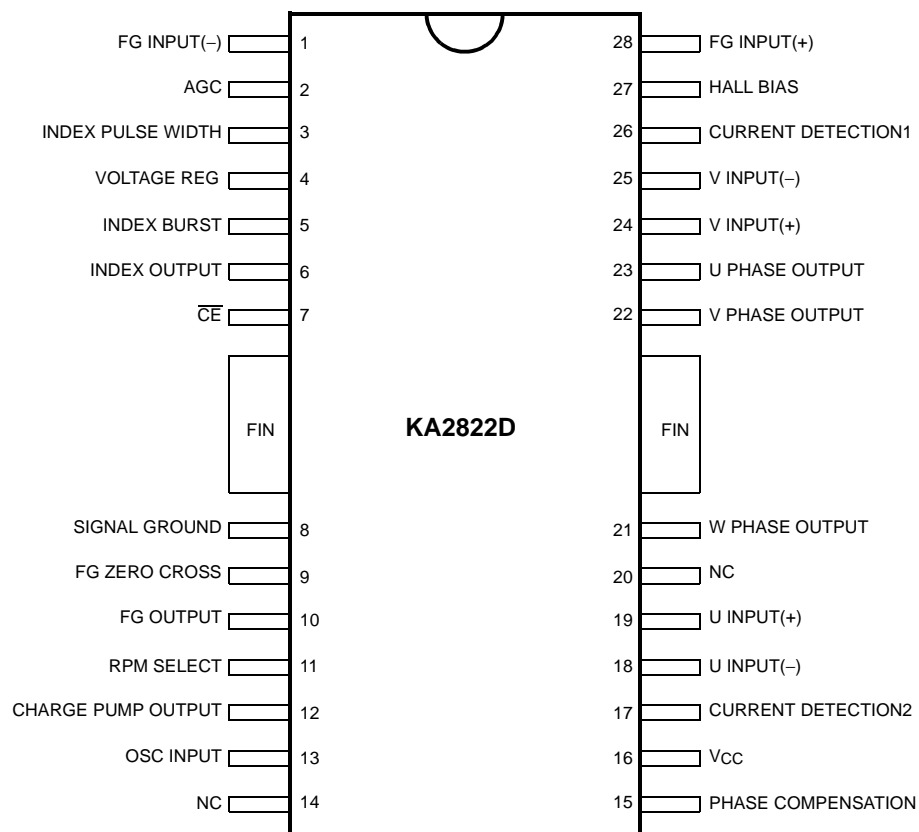

Pin Definitions

Pin Number	Pin Name	I/O	Pin Function Description
1	FG_INPUT	I	Negative input pin FG signal amp.
2	AGC	I	Automatic gain control input pin
3	INDEX PULSE WIDTH	O	Index pulse width detection (1.1V) pin
4	VOLTAGE REGULATOR	O	Voltage (2.2V) generator output pin
5	INDEX BURST	O	Index pulse width detection (1.4V) pin
6	INDEX OUTPUT	O	Index pulse output pin
7	CE	I	Chip enable (Active low)
8	SIGNAL GROUND	-	Signal ground
9	FG ZERO CROSS	O	FG signal zero cross detection pin
10	FG OUTPUT	O	FG signal output pin
11	RPM SELECT	I	RPM selection pin (L: 300, H: 360rpm)
12	CHARGE PUMP OUTPUT	O	Charge pump output pin
13	OSC INPUT	I	1MHz oscillation input pin
14	NC	-	No connection
15	PHASE COMPENSATION	I	Phase compensation cap. connection pin
16	Vcc	-	5V power supply pin
17	CURRENT DETECTION2	I	Over current detection pin
18	U INPUT (-)	I	Negative input pin of U phase amp
19	U INPUT (+)	I	Positive input pin of U phase amp
20	NC	-	No connection
21	W PHASE OUTPUT	O	W phase output pin
22	V PHASE OUTPUT	O	V phase output pin
23	U PHASE OUTPUT	O	U phase output pin
24	U INPUT (+)	I	Positive input pin of V phase amp
25	V INPUT (-)	I	Negative input pin of V phase amp
26	CURRENT DETECTION1	I	Over current detection pin
27	HALL BIAS	I	Hall sensor bias input pin
28	FG INPUT (+)	I	Positive input pin of FG signal amp
FIN	POWER GROUND	-	Power ground

Internal Block Diagram

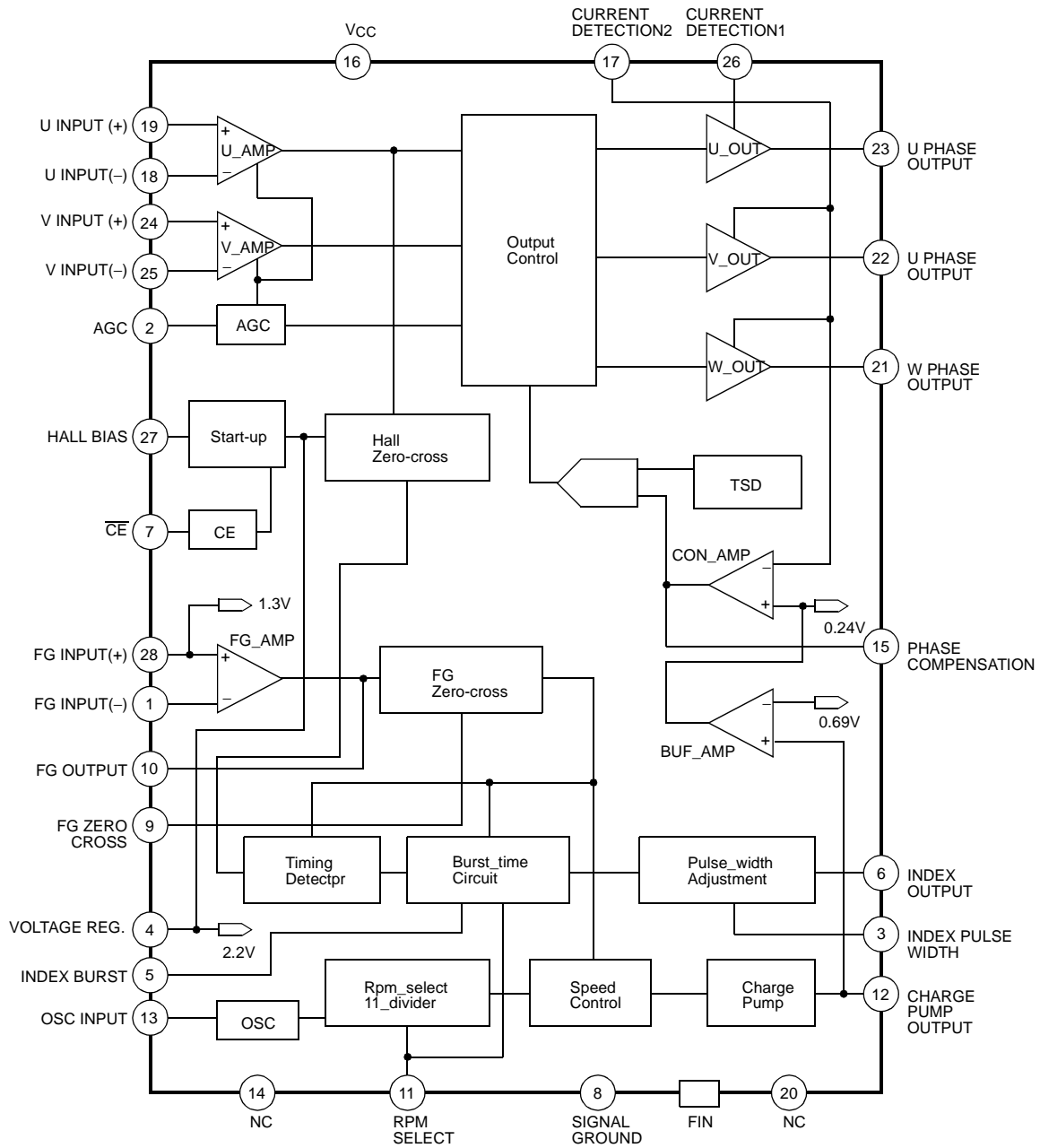

Equivalent Circuits

<p>U_amp, V_amp input</p>	<p>U, V, W drive output and current detection 1, 2</p>
<p>FG input and FG output</p>	<p>OSC input</p>
<p>CE input</p>	<p>Hall bias input and voltage regulator output</p>

Equivalent Circuits (Continued)

<p style="text-align: center;">Index pulse width detection output</p>	<p style="text-align: center;">Phase compensation and current detection 1, 2</p>
<p style="text-align: center;">RPM select input</p>	<p style="text-align: center;">AGC input</p>
<p style="text-align: center;">Index output</p>	<p style="text-align: center;">Index burst output</p>

Equivalent Circuits (Continued)

FG zero cross output

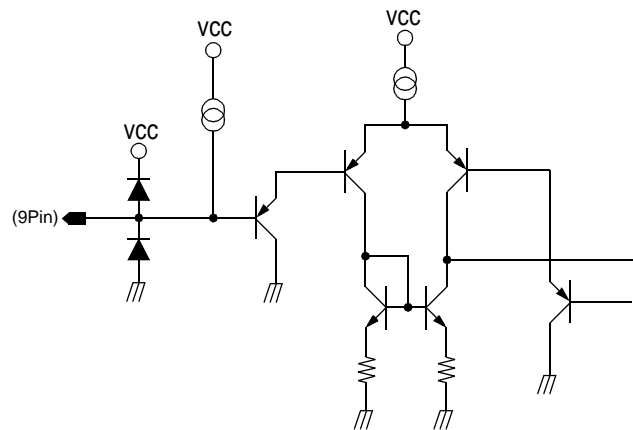

Charge pump output

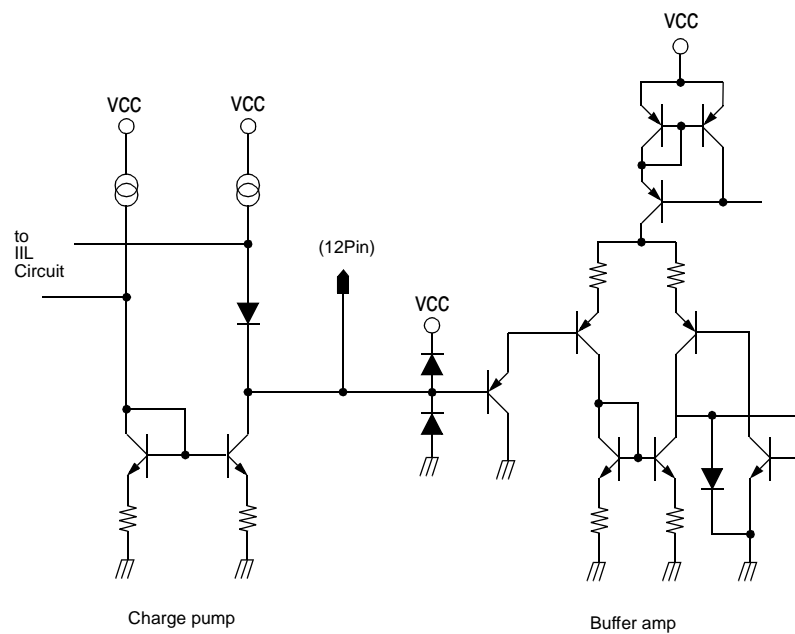

Absolute Maximum Rating (Ta=25°C)

Parameter	Symbol	Value	Unit
Maximum power supply voltage	VCCMAX	7.0	V
Maximum input voltage	VINMAX	0 ~ VCC	V
Maximum output current	IOMAX	1	A
Normal output current	IO	0.7	A
Power dissipation	PD	1.5	W
Operating temperature	TA	0 ~ 75	°C
Junction temperature	TJ	150	°C
Storage temperature	TSTG	-55 ~ +125	°C

Power Dissipation Curve

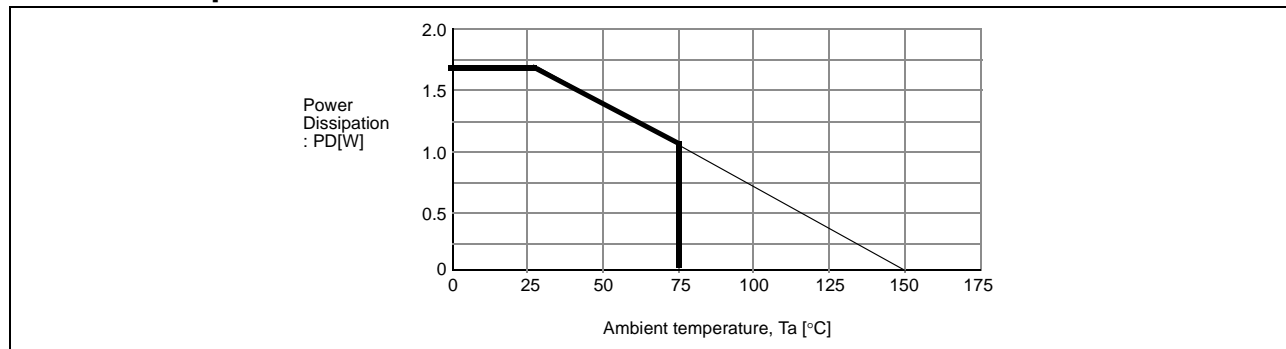

Power dissipation decreases in the rate of 13.5mW / °C when mounted on 50mm × 50mm × 1mm PCB (Phenolic resin material) and used above Ta=25°C.

Recommended Operating Conditions (Ta=25°C)

Parameter	Symbol	Min.	Typ.	Max	Unit
Supply voltage	VCC1, VCC2	10.8	12.0	13.2	V
Supply voltage in logic part	VCC3	4.5	5.0	5.5	V
Ambient operating temperature range	Ta	0	-	+70	°C

Temperature Characteristic

Parameter	Symbol	Min.	Typ.	Max	Unit
Thermal shutdown temperature ^{note}	TSD	125	150	-	°C

NOTE:

Reference value

Electrical Characteristics

($T_a=25^{\circ}\text{C}$, $V_{CC}=5\text{V}$)

Parameter	Symbol	Conditions	Min.	Typ.	Max.	Units
SUPPLY CURRENT						
Supply current 1	I_{CCO}	$V_{CC}=6.5\text{V}$ $\overline{CE}=H$, $RPM=L$	-	1.0	2.0	mA
Supply current 2	I_{CC}	$V_{CC}=6.5\text{V}$, $\overline{CE}=L$	-	15	23	mA
CHIP ENABLE						
Input current	I_{CE}	$\overline{CE}=0\sim 5\text{V}$	-	5	10	μA
Input low voltage	I_{CE1}	-	-	-	1.0	V
Input high voltage	I_{CEH1}	-	3.5	-	-	V
RPM SELECT						
Input current	I_{RPM}	$\overline{CE}=0\sim 5\text{V}$	-	5	10	μA
Input low voltage	V_{RPM1}	-	-	-	1.0	V
Input high voltage	V_{RPMH}	-	3.5	-	-	V
HALL AMP						
Input resistance ^{note}	R_{IN}	-	1	10	-	$\text{k}\Omega$
Common mode input voltage range ^{note}	V_{COM}	-	2.0	-	V_{CC}	V
Differential input voltage range ^{note}	V_{DIF}	-	100	-	420	mV _{PP}
START-UP						
Hall bias voltage 1	V_{HB1}	$I_H=4\text{mA}$, $\overline{CE}=L$	2.3	2.5	2.7	V
Hall bias voltage 2	V_{HB2}	$I_H=10\text{mA}$, $\overline{CE}=L$	2.7	2.9	3.1	V
Reference voltage	V_{ref}	$I_O=1\text{mA}$, $\overline{CE}=L$	1.7	2.2	2.7	V
Bias off current	I_{HOFF}	$V_H=7\text{V}$, $\overline{CE}=H$	-	5	10	μA
OUTPUT AMP						
Leakage current	I_{CER}	-	-	0.5	1	mA
Saturation voltage 1	V_{sat1}	$I_O=0.35\text{A}$	-	1.0	1.2	V
Saturation voltage 2	V_{sat2}	$I_O=0.7\text{A}$	-	1.3	1.8	V
BUFFER & CONTROL AMP						
Voltage gain 1 ^{note}	G_{CT1}	-	-	-11	-	dB
Reference voltage 1 ^{note}	V_{ref1}	Current limiter voltage	0.205	0.208	0.210	V
Reference voltage 2 ^{note}	V_{ref2}	Control begin voltage	-	0.69	-	V

Notes:

Reference value

Electrical Characteristics (Continued)

(Ta=25°C, VCC=5V)

Parameter	Symbol	Conditions	Min.	Typ.	Max.	Units
CHARGE PUMP						
Charge current	ICP-	RPM=L	-15	-20	-25	μA
Discharge current	ICP+	RPM=L	15	20	25	μA
Current ratio ^{note}	IR	ICP+ / ICP-	0.9	1.0	1.1	-
Off current	I _{OFF}	V _{CP} =0.63V	-	-	50	nA
Clamp voltage ^{note}	V _{CLP}	-	-	1.3	1.5	V
FG AMP						
Output DC voltage ^{note}	V _{FG}	-	1.0	1.3	1.6	V
Voltage gain 2	G _{FG}	-	24	34	44	dB
Input voltage range ^{note}	V _{IN}	-	2.0	-	20	mV _{P-P}
Noise margin 1 ^{note}	N _D	Differential noise	-	-	0.5	mV _{P-P}
Noise margin 2 ^{note}	N _C	Common mode noise	-	-	0.5	V _{P-P}
SPEED CONTROL						
Count range 1 ^{note}	N1	RPM=L	-	1666.5	-	-
Count range 2 ^{note}	N2	RPM=H	-	1388.5	-	-
Operating freq.	F _D	-	-	1.0	1.1	MHz
BURST ADJUSTMENT						
Input current	I _{BI}	-	-	1	2	μA
Threshold voltage 1	V _{TH1}	RPM=L	1.2	1.45	1.7	V
Threshold voltage 2	V _{TH2}	RPM=H	1.05	1.3	1.55	V
PULSE WIDTH ADJUSTMENT						
Ct2 charge current	I _{CT2}	-	-19	-25	-36	μA
Threshold voltage 3	V _{TH3}	-	0.9	1.1	1.3	V
INDEX OUTPUT						
Output leakage current ^{note}	I _{OH}	-	-	1	2	μA
Output low voltage	V _{O1}	I _O =1mA	-	0.2	0.4	V

Notes:

Reference value

Application Information

1. CHIP ENABLE

This function turns on or off all blocks by low or high signal.

2. U, V AND W PHASE OUTPUT AMP

These amplifiers drives three output phases - U, V, and W which have 120(degree) phase differences with each other. The three phase waveforms are made with the two hall sensor signals by synthesizing the third phase signal.

3. SPEED CONTROL PART

This function compares the real motor rotation frequency with the 300 or 360Hz pulse divided from 1MHz clock pulse for removing speed error when motor is on and speed error is detected by PLL.

The speed error sent to charge pump part which repeats charge and discharge controls the output current of the output amp to keep a stable rotation.

Typical Performance Characteristics

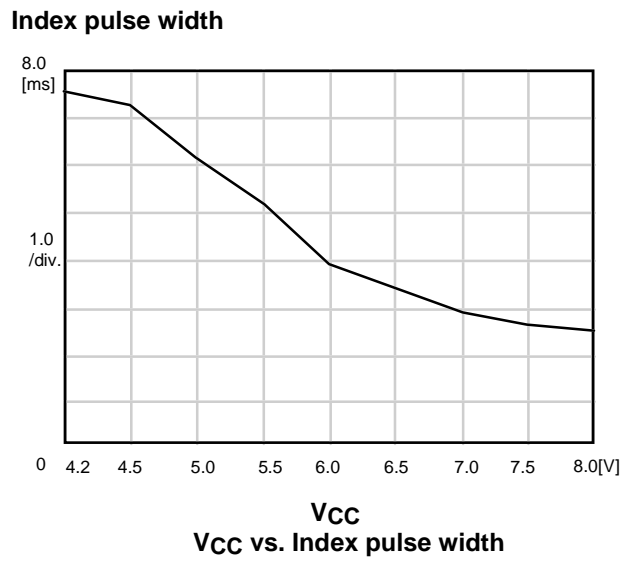
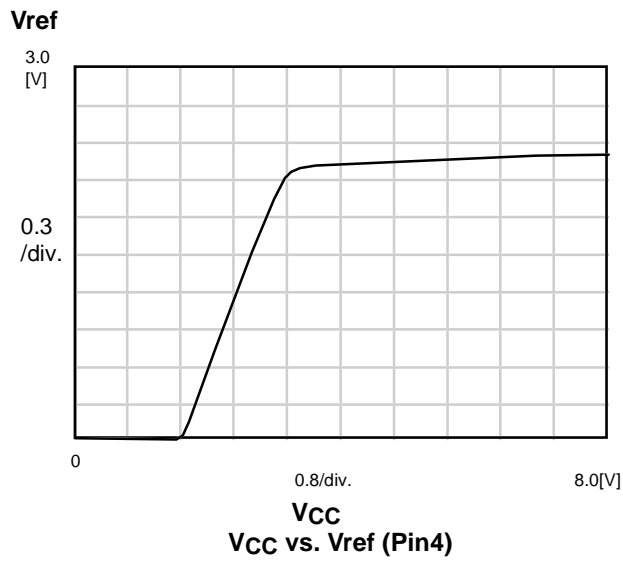
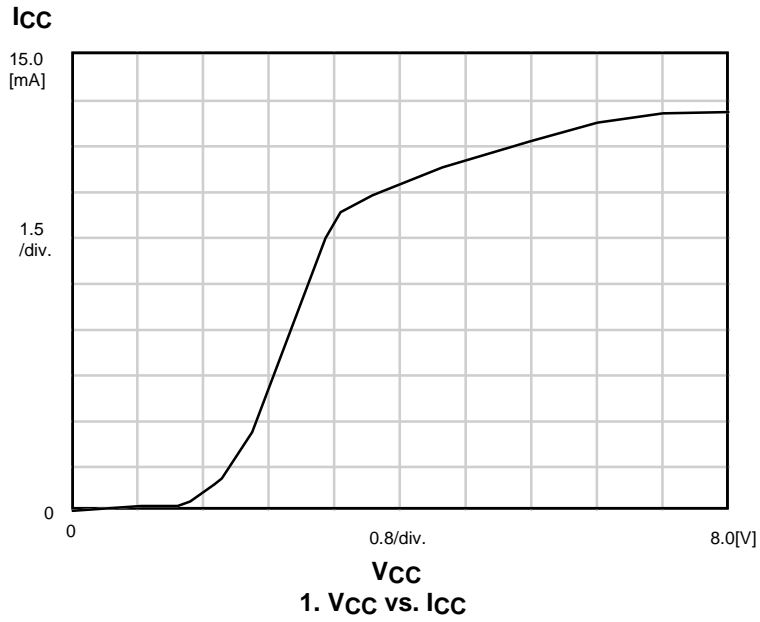

Typical Application Circuits

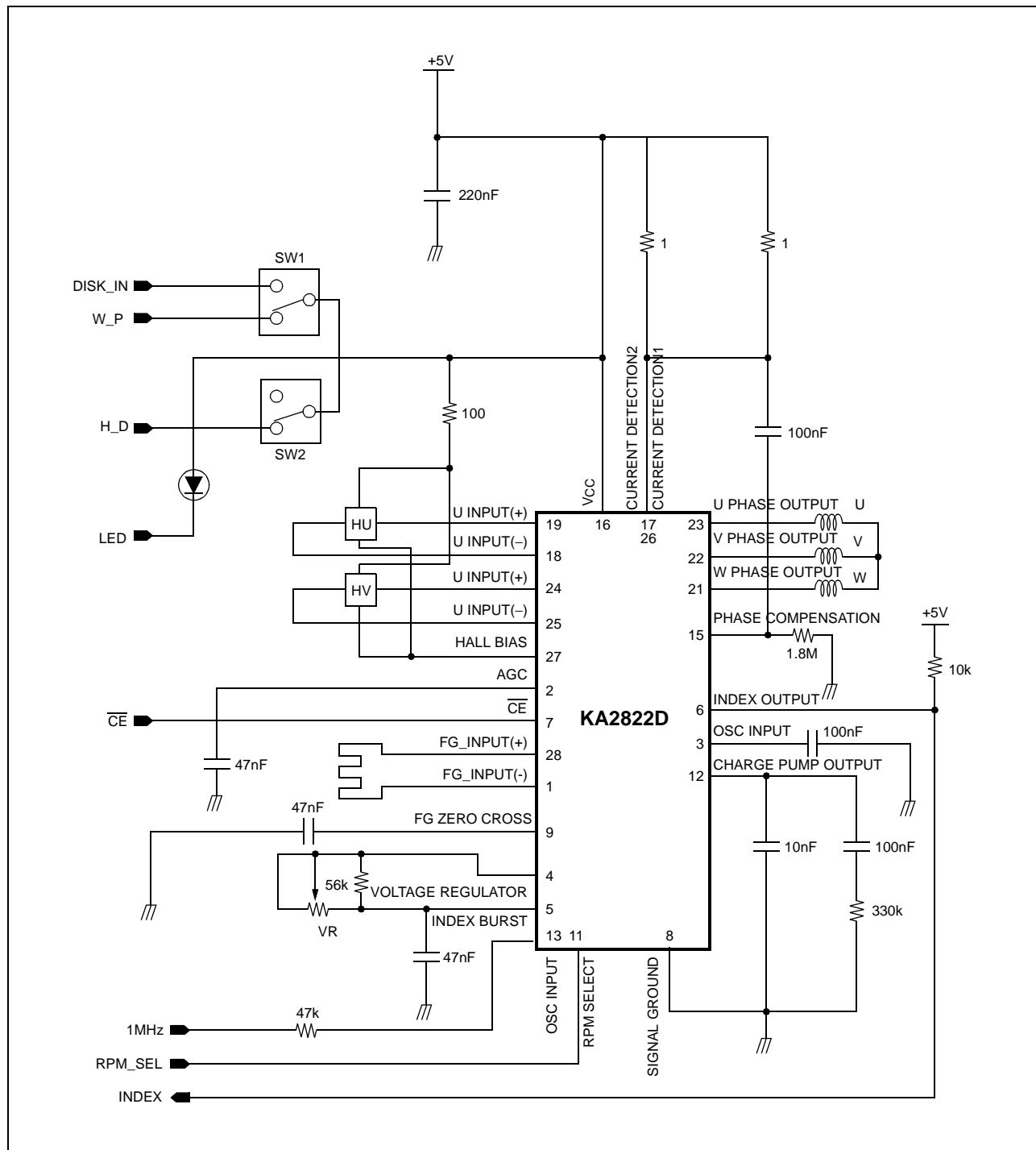

28-SSOPH-375

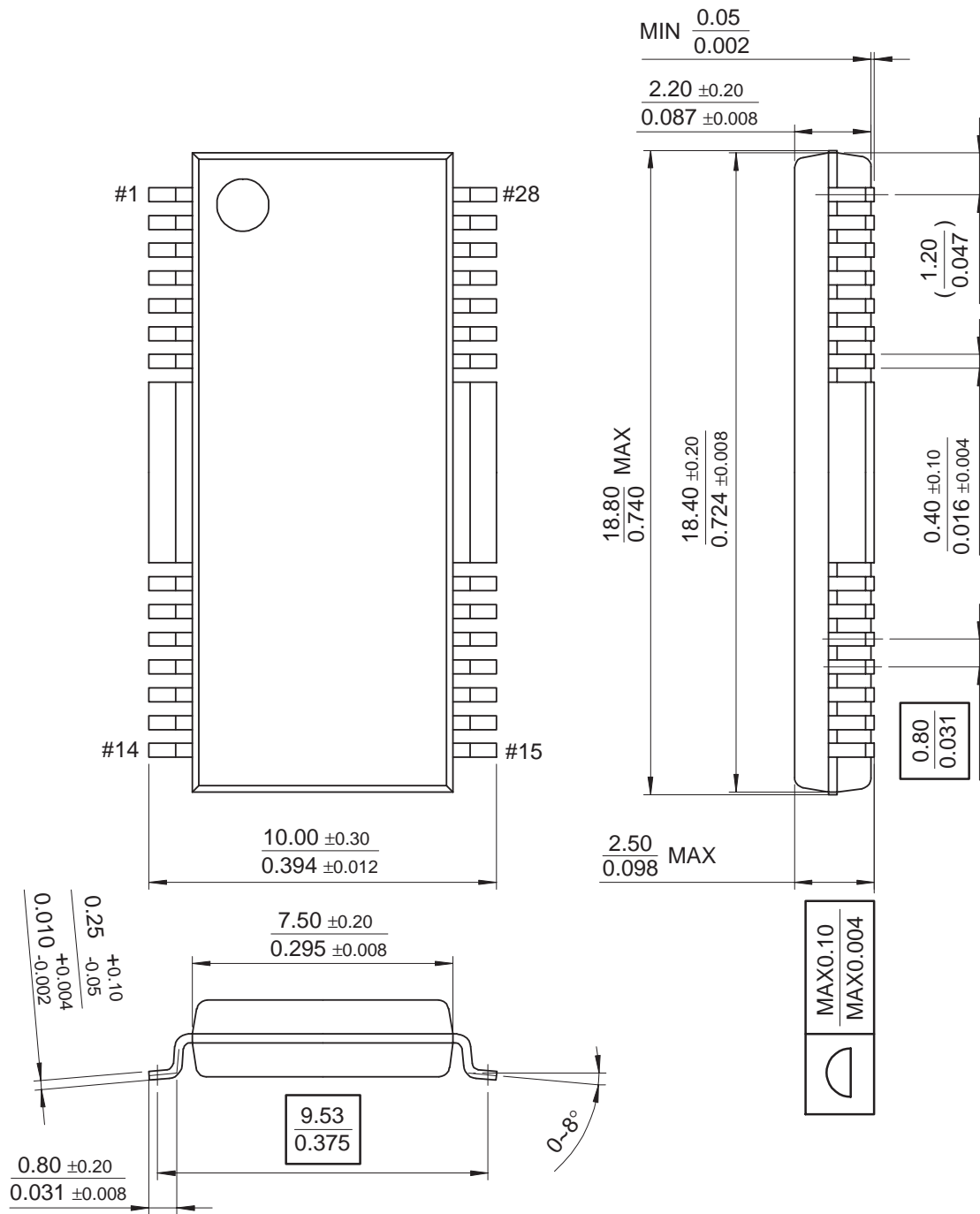

TRADEMARKS

The following are registered and unregistered trademarks Fairchild Semiconductor owns or is authorized to use and is not intended to be an exhaustive list of all such trademarks.

ACE ^x TM	FAST ^r TM	QFET TM	VCX TM
Bottomless TM	GlobalOptoisolator TM	QS TM	
CoolFET TM	GTO TM	QT Optoelectronics TM	
CROSSVOLT TM	HiSeC TM	Quiet Series TM	
DOME TM	ISOPANAR TM	SuperSOT TM -3	
E ² CMOS TM	MICROWIRE TM	SuperSOT TM -6	
EnSigna TM	OPTOLOGIC TM	SuperSOT TM -8	
FACT TM	OPTOPLANAR TM	SyncFET TM	
FACT Quiet Series TM	POP TM	TinyLogic TM	
FAST [®]	PowerTrench [®]	UHC TM	

DISCLAIMER

FAIRCHILD SEMICONDUCTOR RESERVES THE RIGHT TO MAKE CHANGES WITHOUT FURTHER NOTICE TO ANY PRODUCTS HEREIN TO IMPROVE RELIABILITY, FUNCTION OR DESIGN. FAIRCHILD DOES NOT ASSUME ANY LIABILITY ARISING OUT OF THE APPLICATION OR USE OF ANY PRODUCT OR CIRCUIT DESCRIBED HEREIN; NEITHER DOES IT CONVEY ANY LICENSE UNDER ITS PATENT RIGHTS, NOR THE RIGHTS OF OTHERS.

LIFE SUPPORT POLICY

FAIRCHILD'S PRODUCTS ARE NOT AUTHORIZED FOR USE AS CRITICAL COMPONENTS IN LIFE SUPPORT DEVICES OR SYSTEMS WITHOUT THE EXPRESS WRITTEN APPROVAL OF FAIRCHILD SEMICONDUCTOR CORPORATION. As used herein:

1. Life support devices or systems are devices or systems which, (a) are intended for surgical implant into the body, or (b) support or sustain life, or (c) whose failure to perform when properly used in accordance with instructions for use provided in the labeling, can be reasonably expected to result in significant injury to the user.
2. A critical component is any component of a life support device or system whose failure to perform can be reasonably expected to cause the failure of the life support device or system, or to affect its safety or effectiveness.

PRODUCT STATUS DEFINITIONS

Definition of Terms

Datasheet Identification	Product Status	Definition
Advance Information	Formative or In Design	This datasheet contains the design specifications for product development. Specifications may change in any manner without notice.
Preliminary	First Production	This datasheet contains preliminary data, and supplementary data will be published at a later date. Fairchild Semiconductor reserves the right to make changes at any time without notice in order to improve design.
No Identification Needed	Full Production	This datasheet contains final specifications. Fairchild Semiconductor reserves the right to make changes at any time without notice in order to improve design.
Obsolete	Not In Production	This datasheet contains specifications on a product that has been discontinued by Fairchild semiconductor. The datasheet is printed for reference information only.

Rev. F1