

# KA3017

## Spindle + 4-CH Motor Driver

### Features

- Built-in Power Save Circuit
- Built-in Current Limit Circuit
- Built-in Thermal Shutdown Circuit (TSD)
- Built-in Hall Bias
- Built-in FG Signal Output Circuit
- Built-in Rotational Direction Detecting Circuit
- Built-in Protection Circuit For Reverse Rotation
- Built-in Short Brake Circuit
- Built-in Normal OP-AMP
- Built-in 4-CH Balanced Transformerless (BTL) Driver
- Built-in BTL MUTE Circuit (CH1-2, CH3 and CH4)
- Corresponds to 3.3V DSP

### Description

The KA3017 is a monolithic integrated circuit suitable for a 4-CH motor driver which drives the tracking actuator, focus actuator, sled motor, loading motor and 3-phase BLDC spindle motor of the MDP/CAR-MD/CAR-NAVIGATION system.

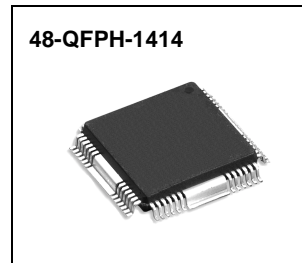

### Target Application

- Mini Disk Player
- Digital Video Disk Player
- Car Mini Disk Player
- Car Navigation System

### Ordering Information

Device	Package	Operating Temp.
KA3017	48-QFPH-1414	-35°C ~ +85°C



## Pin Definitions

Pin Number	Pin Name	I/O	Pin Function Description
1	VH	I	Hall Bias
2	FG	O	FG Signal Output
3	ECR	I	Torque Control Reference
4	EC	I	Torque Control Signal
5	VCC2	-	Supply Voltage
6	PC1	-	Phase Compensation Capacitor
7	SIGGND	-	Signal Ground
8	VM	-	Motor Supply Voltage
9	CS1	I	Current Sensor
10	S/S	I	Start/Stop
11	DIR	O	3-Phase Rotational Direction Output
12	SB	I	Short Brake
13	PWRGND	-	Power Ground
14	A3	O	3-Phase Output 3
15	A2	O	3-Phase Output 2
16	A1	O	3-Phase Output 1
17	OPIN+	I	OP-AMP Input (+)
18	OPIN-	I	OP-AMP Input (-)
19	OPOUT	O	OP-AMP Output
20	VCC1	-	Supply Voltage
21	AVM12	-	BTL CH-1, 2 Motor Supply Voltage
22	DI4	I	BTL Drive Input 4
23	DI3	I	BTL Drive Input 3
24	DI2	I	BTL Drive Input 2
25	DI1	I	BTL Drive Input 1
26	DO1-	O	BTL Drive 1 Output (-)
27	DO1+	O	BTL Drive 1 Output (+)
28	DO2-	O	BTL Drive 2 Output (-)
29	DO2+	O	BTL Drive 2 Output (+)
30	BTLPGND1	-	BTL Power Ground 1
31	BTLPGND2	-	BTL Power Ground 2
32	DO3-	O	BTL Drive 3 Output (-)
33	DO3+	O	BTL Drive 3 Output (+)

**Pin Definitions** (Continued)

Pin Number	Pin Name	I/O	Pin Function Description
34	AVM3	-	BTL CH3 Motor Supply Voltage
35	DO4-	O	BTL Drive 4 Output (-)
36	DO4+	O	BTL Drive 4 Output (+)
37	MUTE4	I	BTL Drive Mute CH4
38	MUTE3	I	BTL Drive Mute CH3
39	MUTE12	I	BTL Drive Mute CH1, 2
40	AVM4	-	BTL CH4 Motor Supply Voltage
41	BIAS	-	BTL Bias Voltage
42	BTLSGND	-	BTL Drive Signal Ground
43	H1-	I	Hall1(-) Input
44	H1+	I	Hall1(+) Input
45	H2-	I	Hall2(-) Input
46	H2+	I	Hall2(+) Input
47	H3-	I	Hall3(-) Input
48	H3+	I	Hall3(+) Input

## Internal Block Diagram

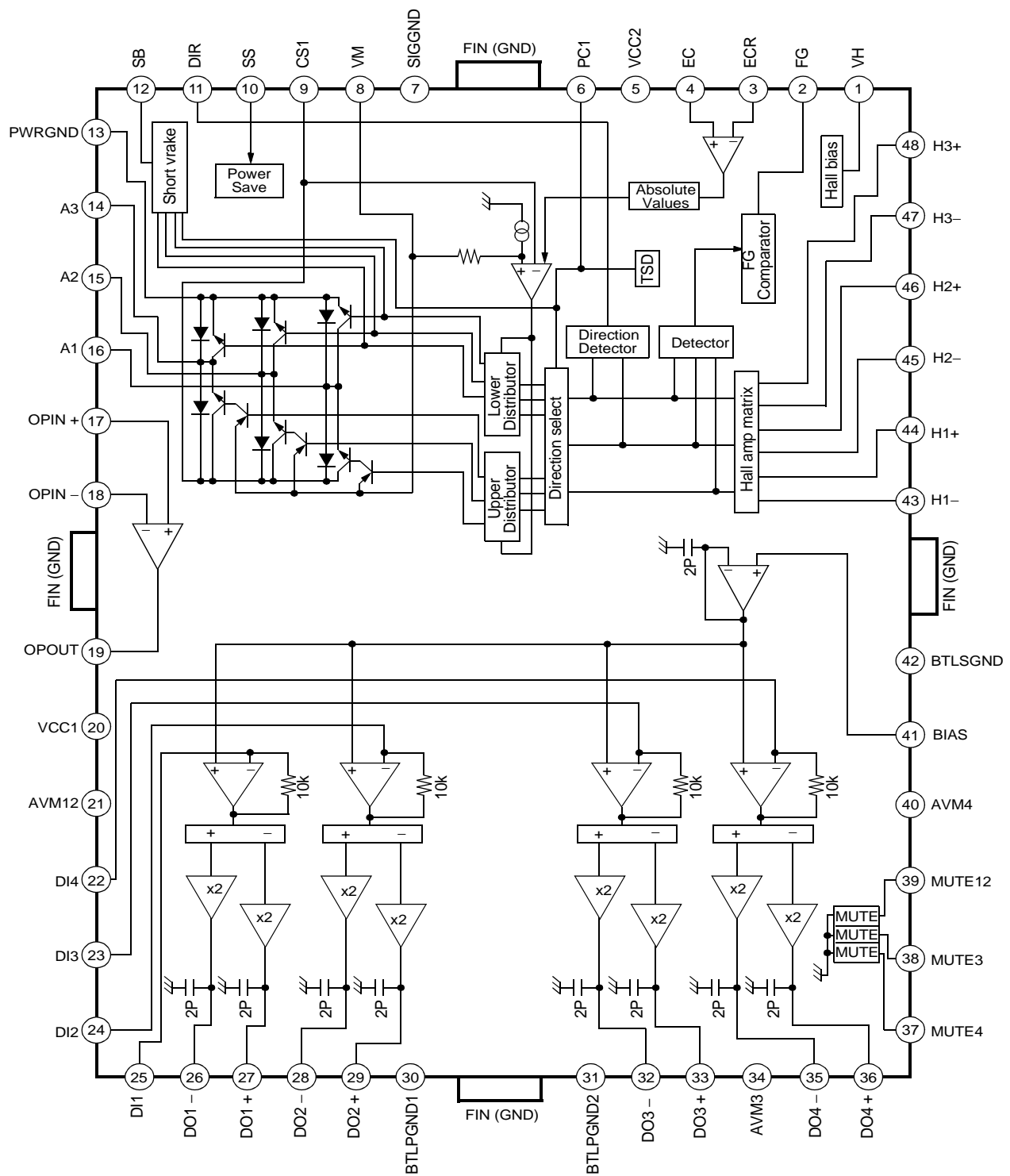

## Equivalent Circuits

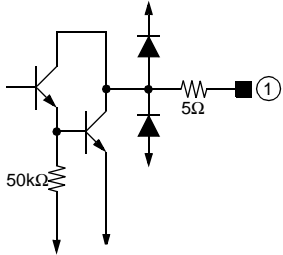
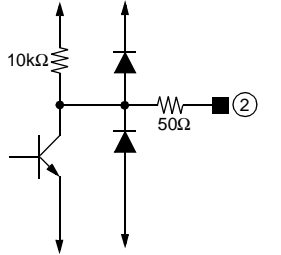
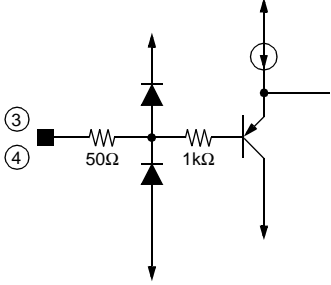
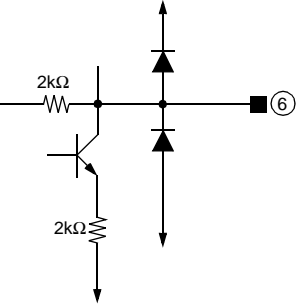
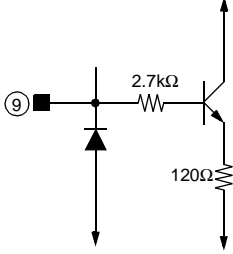
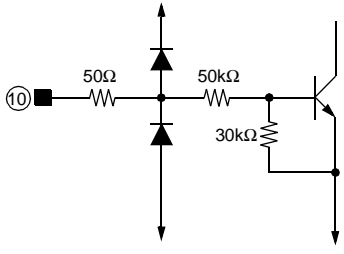
Hall Bias	FG Signal Output
	
Torque Control Reference & Signal	Phase Compensation Capacitor
	
Current Detector	Start/Stop
	

## Equivalent Circuits (Continued)

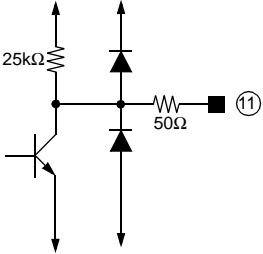
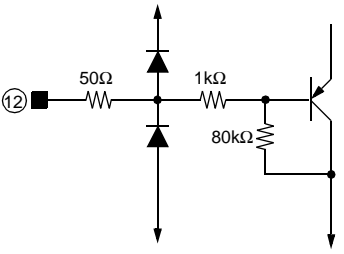
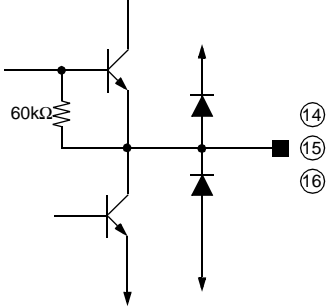
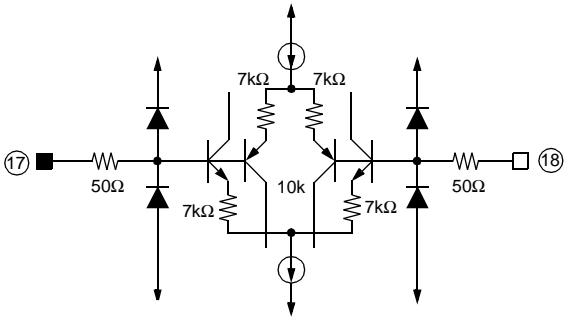
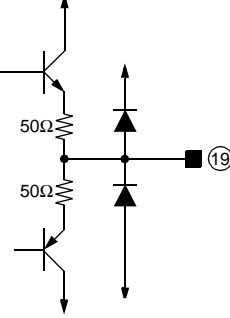
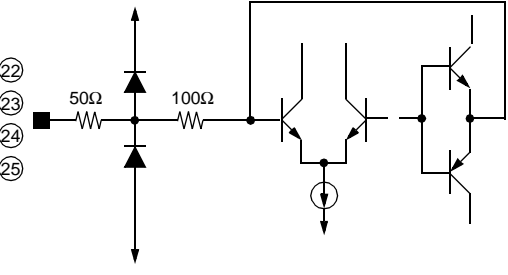
<p style="text-align: center;"><b>3-Phase Rotational Direction Output</b></p> 	<p style="text-align: center;"><b>Short Brake</b></p> 
<p style="text-align: center;"><b>3-Phase Output</b></p> 	<p style="text-align: center;"><b>OP-AMP Input</b></p> 
<p style="text-align: center;"><b>OP-AMP Output</b></p> 	<p style="text-align: center;"><b>BTL Drive Input</b></p> 

### Equivalent Circuits (Continued)

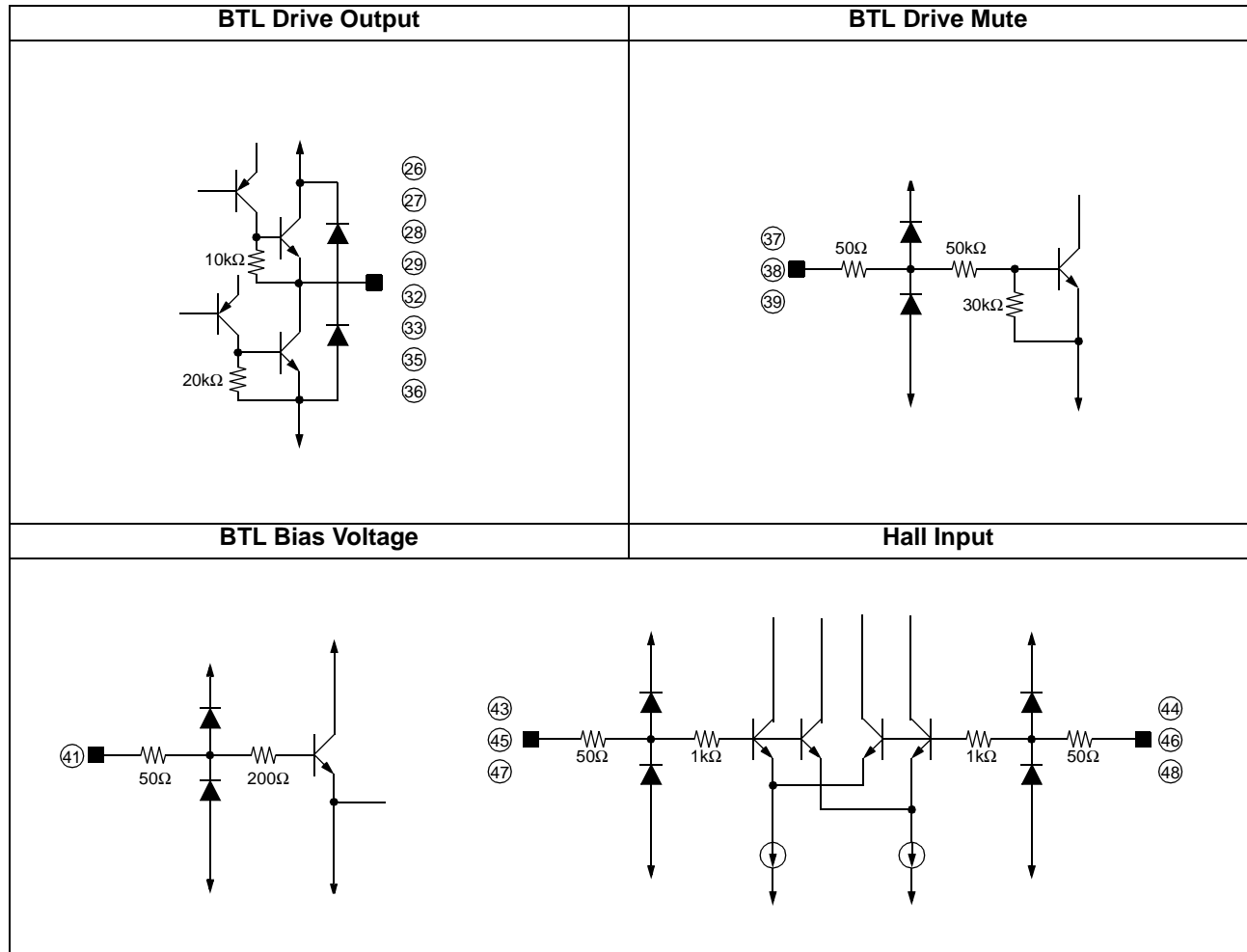



## Absolute Maximum Ratings ( Ta=25°C)

Parameter	Symbol	Value	Unit
Supply Voltage (BTL Signal)	VCC1max	15	V
Supply Voltage (Spindle Signal)	VCC2max	7	V
Supply Voltage (Motor)	VMmax	15	V
Supply Voltage (BTL Motor)	VMBTLmax	15	V
Power Dissipation	Pd	3.0 <sup>note</sup>	W
Operating Temperature Range	Topr	-35 ~ +85	°C
Storage Temperature Range	Tstg	-55 ~ +150	°C
Maximum Output Current (Spindle Part)	IOMAXS	1.3	A
Maximum Output Current (BTL Part)	IOMAXB	1	A

### Note:

- When mounted on 70mm × 70mm × 1.6mm PCB (Phenolic resin material)
- Power dissipation is reduced 24mW/°C for using above Ta=25°C
- Do not exceed Pd and SOA (Safe Operating Area).

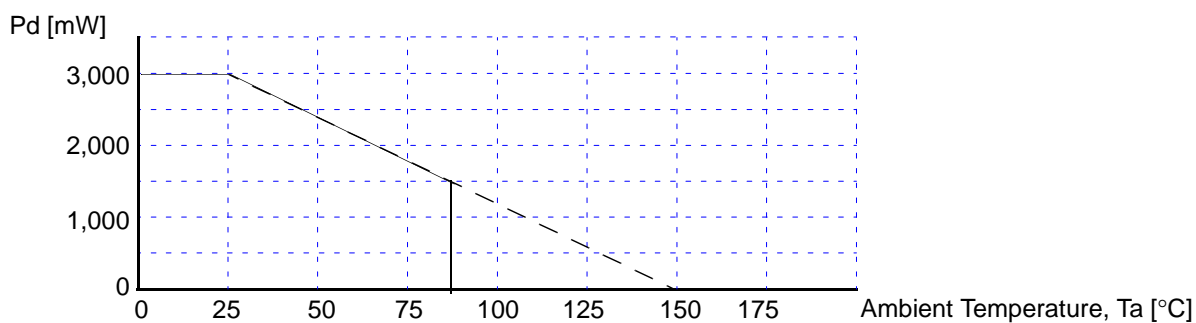

## Recommended Operating Conditions ( Ta=25°C)

Parameter	Symbol	Min.	Typ.	Max.	Unit
Operating Supply Voltage (BTL Signal)	VCC1	4.5	-	13.2	V
Operating Supply Voltage (Spindle Signal)	VCC2	4.5	-	5.5	V
Operating Supply Voltage ( Spindle Motor)	VM	4.5	-	13.2	V
Operating Supply Voltage (BTL Motor)	VMBTL	4.5	-	VCC1	V

**Electrical Characteristics** (Ta=25°C, VCC2=5V, VM=12V)

Parameter	Symbol	Condition	Min.	Typ.	Max.	Unit
Circuit Current 1	ICC 1	Power Save = 0V	-	0	0.1	mA
Circuit Current 2	ICC2	Power Save = 5V	-	8.0	-	mA
<b>START/STOP</b>						
On Voltage Range	VPSON	L-H Circuit On	2.5	-	-	V
Off Voltage Range	VPSOFF	H-L Circuit Off	-	-	0.5	V
<b>HALL BIAS</b>						
Hall Bias Voltage	VHB	IHB = 20mA	-	1.2	1.8	V
<b>HALL AMP</b>						
Hall Bias Current	IHA	-	-	1	5	uA
In-phase in Voltage Range	VHAR	-	1.5	-	4.0	V
Minimum in Level <sup>note</sup>	VINH	-	60	-	-	mVpp
<b>TORQUE CONTROL</b>						
In Voltage Range	EC		0.5	-	3.3	V
Offset Voltage (-) <sup>note</sup>	ECOFF-	ECR = 2.5V	-80	-50	-20	mV
Offset Voltage (+)	ECOFF+	ECR = 2.5V	20	50	80	mV
In Current	ECIN	EC = ECR = 2.5V	-5	-1	-	uA
In/Output Gain	GEC	ECR = 2.5V, RCS = 0.5Ω	0.41	0.51	0.61	A/V
<b>FG</b>						
FG Output Voltage (H)	VFGH	IFG = -10uA	3.0	-	VCC	V
FG Output Voltage (L)	VFHL	IFG = 10uA	-	-	0.5	V
Input Voltage Range <sup>note</sup>	VFGR	Hn+, Hn- input D-range	1.5	-	4.0	V
<b>OUTPUT BLOCK</b>						
Saturation Voltage (upper TR)	VOH	IO = -300mA	-	0.9	1.6	V
Saturation Voltage (lower TR)	VOL	IO = 300mA	-	0.2	0.6	V
Torque Limit Current	ITL	RCS = 0.5Ω	560	700	840	mA
<b>DIRECTION DETECTOR</b>						
Dir Output Voltage (H)	VDIRH	IFG = -10uA	3.0	-	VCC	V
Dir Output Voltage (L)	VDIRL	IFG = 10uA	-	-	0.5	V
<b>SHORT BRAKE</b>						
On Voltage Range	VSBON	-	2.5	-	VCC	V
Off Voltage Range	VSBOFF	-	0	-	0.5	V

**Note:** Guranteed field. (No EDS / Final test)

**Electrical Characteristics** (Continued)

BTL Drive Part (Ta=25°C, VCC1=12V, VMBTL=12V, RL=24Ω)

Parameter	Symbol	Condition	Min.	Typ.	Max.	Unit
Quiescent Circuit Current	ICC	-	-	9	15	mA
Output Offset Voltage	VOO	-	-30	-	30	mV
Maximum Output Amplitude Voltage	VOM	-	9.5	10.5	-	V
Voltage Gain	GVC	VIN=0.1Vrms, 1kHz	10.5	12.0	13.5	dB
Ripple Rejection Ratio <sup>note</sup>	RR	VIN=0.1Vrms, 120kHz	-	60	-	dB
Slew Rate <sup>note</sup>	SR	120Hz, 2Vpp	-	1.0	-	V/us
CH Mute Off Voltage	VMOFFCH	Pin37, 38, 39 = Variation	-	-	0.5	V
CH Mute On Voltage	VMONCH	Pin37, 38, 39 = Variation	2.5	-	-	V
<b>NORMAL OP- AMP</b>						
Input Offset Voltage	VOF	-	-10	-	+10	mV
Input Bias Current	IB1	-	-	-	300	nA
High Level Output Voltage	VOH1	-	11	-	-	V
Low Level Output Voltage	VOL1	-	-	-	0.1	V
Output Sink Current	ISINK	-	10	20	-	mA
Output Source Current	ISOU1	-	10	20	-	mA
Open Loop Voltage Gain <sup>note</sup>	GVO1	f=1kHz, VIN= -75dB	-	75	-	dB
Ripple Rejection Ratio <sup>note</sup>	RR1	f=120Hz, VIN= -20dB	-	65	-	dB
Slew Rate <sup>note</sup>	SR1	f=120Hz, 2Vp-p	-	1	-	V/us
Common Mode Rejection Ratio <sup>note</sup>	CMRR1	f=1kHz, VIN= -20dB	-	80	-	dB

**Note:** Guranteed field. (No EDS / Final test)

## Calculation of Gain & Torque Limit Current

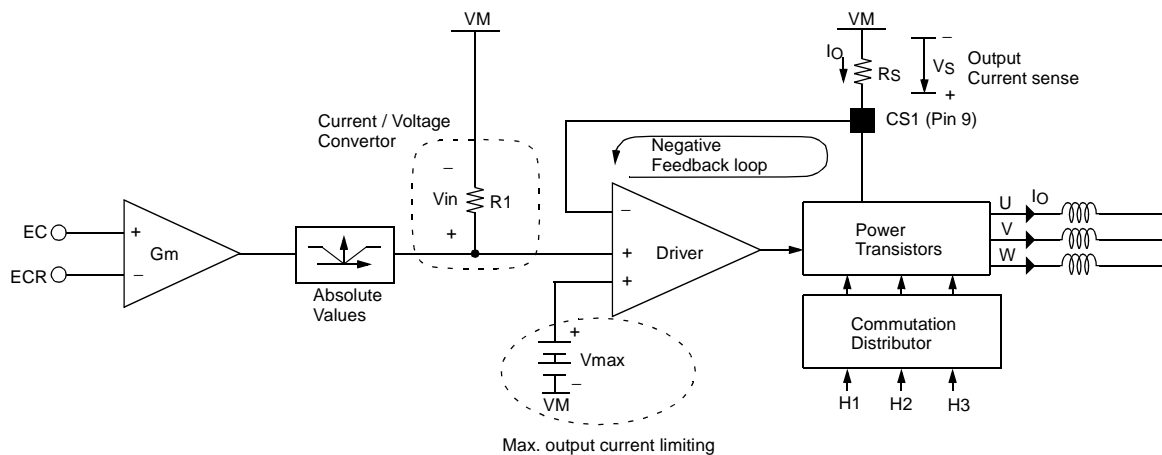

0.255 is made from GM times R1 and is a fixed value within IC.

$$\text{Gain} = \frac{0.255}{R_S}$$

Vmax (see above block diagram) is set to 350mV.

$$I_{tI}[\text{mA}] = \frac{V_{\text{max}}}{R_S} = \frac{350[\text{mV}]}{R_S}$$

## Application Information

### 1. Mute Function

#### 1) Mute Control Voltage Condition

When using the mute function, the applied control voltage condition is as follows.

Mute On Voltage	2.5[V] Above	Mute Function Operation
Mute Off Voltage	OPEN or 0.5[V] Below	Normal Operation

#### 2) Individual channel Mute Function

These pins are used for individual channel mute operation.

- When the mute pins (pin 37, 38 and 39) are OPEN or the voltages at the mute pins are below 0.5[V], the mute circuit is disabled and BTL output circuits operate normally.
- When the mute pins (pin 37, 38 and 39) are above 2.5[V], the mute circuits are activated so that the BTL output circuit will be muted.
- If the junction temperature rises above 175°C, then the thermal shutdown (TSD) circuit is activated and all the output circuits (4-CH BTL Drivers and 3-phase BLDC Driver) are muted.

### 2. 4-CH Balanced Transformerless (Btl) Driver

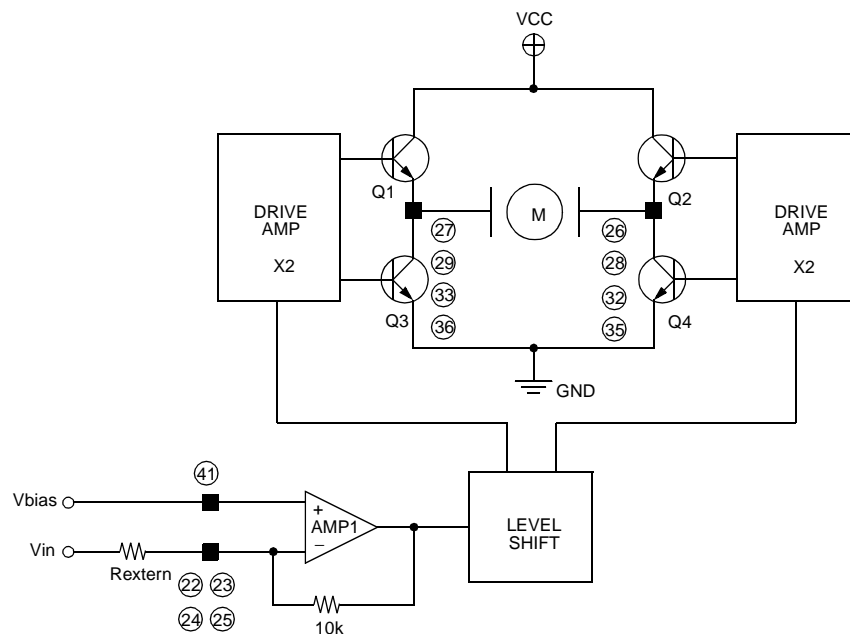

- The voltage, Vbias, is the reference voltage given by the external bias voltage of pin 41.
- The input signals, Vin, through the pins (pin 22, 23, 24 and 25) are amplified 10K/Rextern times and then fed to the level shift.
- The level shift produces the current due to the difference between the input signal (Vin) and the arbitrary reference voltage (Vbias). The current produced as +  $\Delta I$  and -  $\Delta I$  are fed into the drive buffers.
- The drive buffer operates the power TR of the output stage according to the state of the input signal (Vin).
- The output stage is the BTL driver, and the motor (or actuator) rotates in forward direction, when TR Q1 and TR Q4 are on. On the other hand, if TR Q2 and TR Q3 are on, the motor (or actuator) rotates in reverse direction.
- When the input signal Vin, through the pin (pin 22, 23, 24 and 25) is below the Vbias, then the motor (actuator) moves in forward direction.

- When the input signal  $V_{in}$ , through the pin (pin 22, 23, 24 and 25) is above the  $V_{bias}$ , then the motor (actuator) moves in reverse direction.
- To change the gain, modify the external resistor's value ( $R_{extern}$ )

### 3. Torque & Output Current Control

Torque & Output Current Control

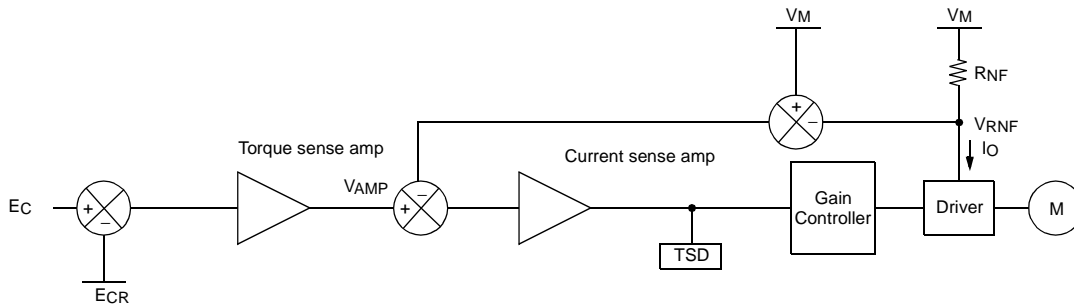

- By amplifying the voltage difference between  $E_C$  and  $E_{CR}$  from the Servo IC, the torque sense AMP produces the input voltage ( $V_{AMP}$ ) for the current sense AMP.
- The current sense AMP produces the input for the Gain controller to allow the output current ( $I_O$ ) of the driver to be controlled by the input voltage ( $V_{AMP}$ ), where the output current ( $I_O$ ) is detected by the sense resistor ( $R_{NF}$ ) and is converted into  $V_{RNF}$ .
- In the end, the signals of the Servo IC control the velocity of the motor by controlling the output current ( $I_O$ ) of the driver.
- When the junction temperature rises up to  $175^\circ\text{C}$ , the output drive circuit shuts down.
- The range of the torque control input voltage is as shown below.

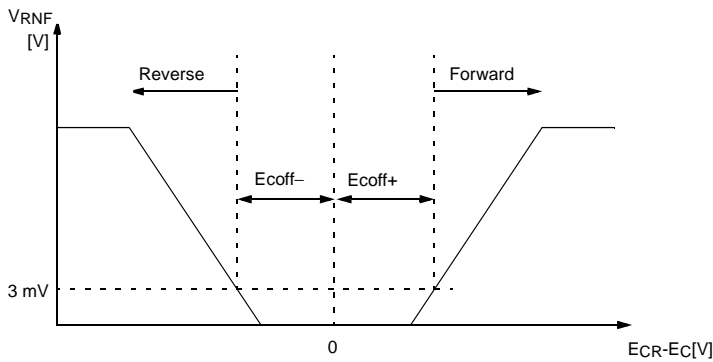

	Rotation
$E_c < E_{CR}$	Forward rotation
$E_c > E_{CR}$	Stop after detecting reverse rotation

The input range ( $E_C$ ) of the Torque Sense AMP is  $0.5\text{V} \sim 3.3\text{V}$

#### 4. Power Save Function

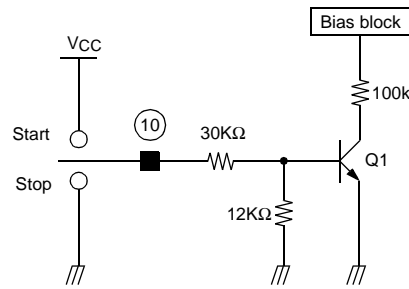

- The power save circuit is activated by operating TR Q1.
- When the SS (Start/Stop) pin 10 is high (VCC), the TR Q1 is turned on and the bias circuit is enabled. On the other hand, when the SS (Start/Stop) pin 10 is Open or Low (GND), the TR Q1 is turned off and the bias circuit is disabled.
- The power save operation controlled by SS (pin 10) input conditions is as follows;

Pin#10	KA3017
High	Start
Open/Low	Stop

#### 5. Short Brake Function

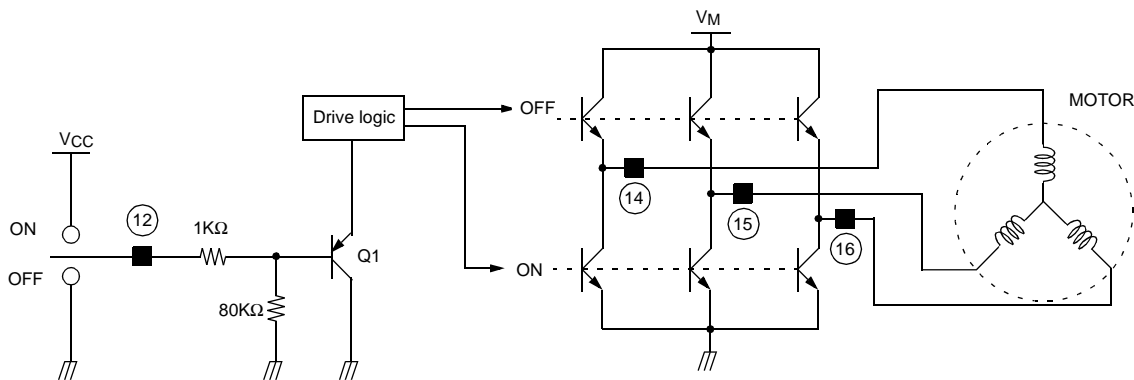

When the pick-up mechanism moves from the inner to the outer spindle of the MD(Mini Disk), the brake function of the reverse voltage is commonly employed to rate the rotational velocity of the spindle motor. However, if the spindle motor rotates rapidly, the brake function of the reverse voltage may produce too much heat at the drive IC.

To remove these shortcomings and to enhance efficiency, the short brake function is added to KA3017. When the short brake function is active, all upper Power transistors are turned off and the lower Power transistors turned on, so as to reduce the rotational velocity of the motor. The short brake operation controlled by SB (pin 12), and the input conditions are as follows.

#### 6. Thermal Shutdown (Tsd) Function

Pin#12	SHORT BRAKE
HIGH	ON
LOW	OFF

When the junction temperature rises up to 175°C, the output drive circuit shuts down, when the junction temperature falls off to 160°C, the output drive circuit operates normally. It has the temperature hysteresis of about 15°C.

## 7. Rotating Direction Detecting Function

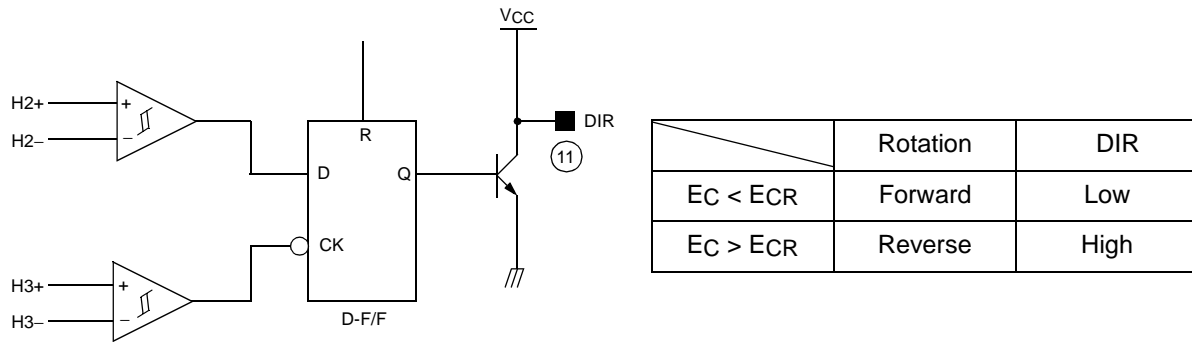

- The forward and reverse rotations of the MD are detected by the circuit, as shown in the above Table.
- The rotational direction of the MD can be learned by the output waveforms of the hall sensor and/or the driver. Hall sensors are turned on in the order,  $H1 \rightarrow H2 \rightarrow H3$  for the reverse rotation. The output waveforms of the hall sensors are as shown below.

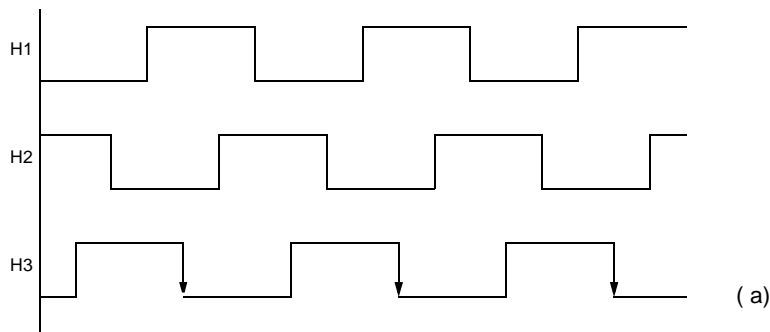

Inversely, if the hall sensors turn on in the order,  $H3 \rightarrow H2 \rightarrow H1$ , then this shows forward rotation. The output waveforms of the hall sensors are as shown below.



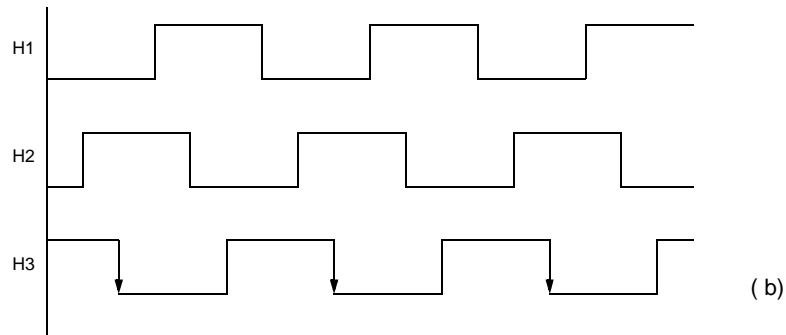

## 8. Reverse Rotation Preventing Function

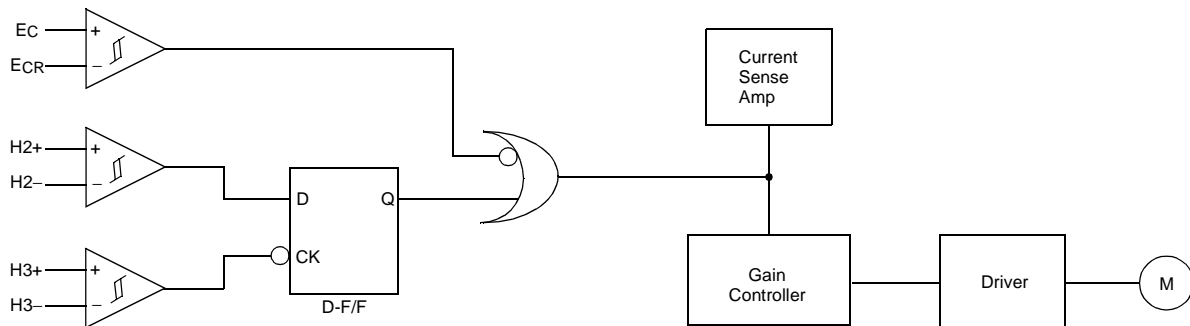

- The forward and reverse rotation of the motor are detected, as shown in the table below. Consequently at reverse rotation, the D-F/F output Q becomes Low and cuts off the output current sense Amp, resulting in the stoppage of the Gain controller function.
- When the MD is rotating in forward direction,  $EC > ECR$  is sometimes controlled to retard and/or stop the MD. As the controlling time of  $EC > ECR$  gets longer, MD slows down, stops, and then rotates in the reverse direction. To prevent the MD from rotating in the reverse direction, a reverse rotation resistant function is required. Its operational principles are discussed below.

Rotation	H2	H3	D-F/F	Reverse Rotation Preventer	
				$EC < ECR$	$EC > ECR$
Forward	H	H → L	H	Forward	Brake and Stop
Reverse	L	H → L	L	–	Stop

## 9. Fg Output Function

The FG output detects the number of rotations of the MD. This is generated from combination zero-crossing of the hall sensor output waveforms. The FG output circuit is as shown below.

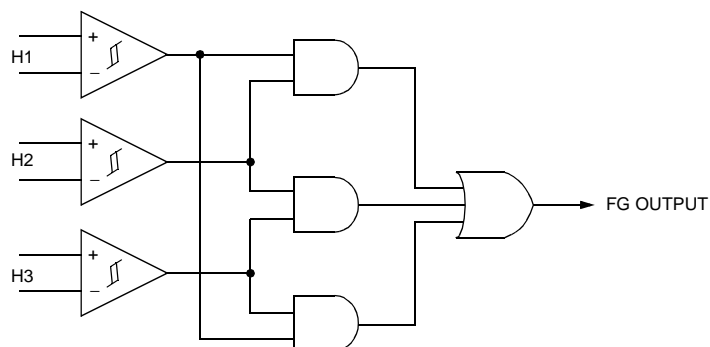

## 10. Hall Sensor Connection

External Hall sensors are used in series or in parallel connection as shown below.

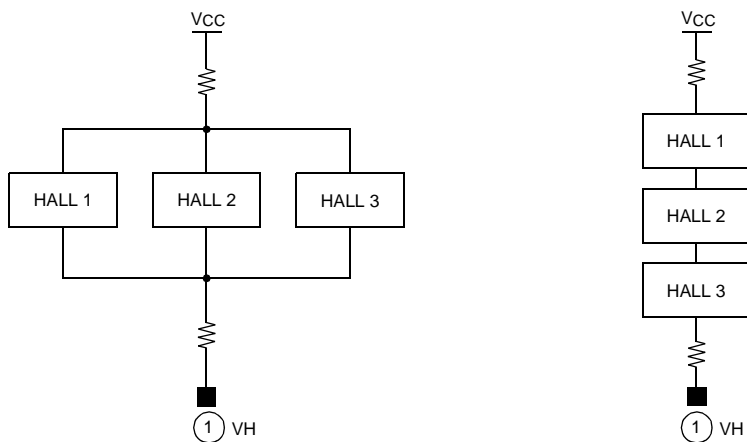

## 11. Hall Input Output Timming Chart

The 3-phase hall signal is amplified in the hall amplifiers and sent to the matrix section, where the signal is further amplified. After the signal is converted to a current in the amplitude control circuit, the current is supplied to the output driver, which then provides a motor drive current. The phases of the hall input signal, output voltage, and output current are shown below.

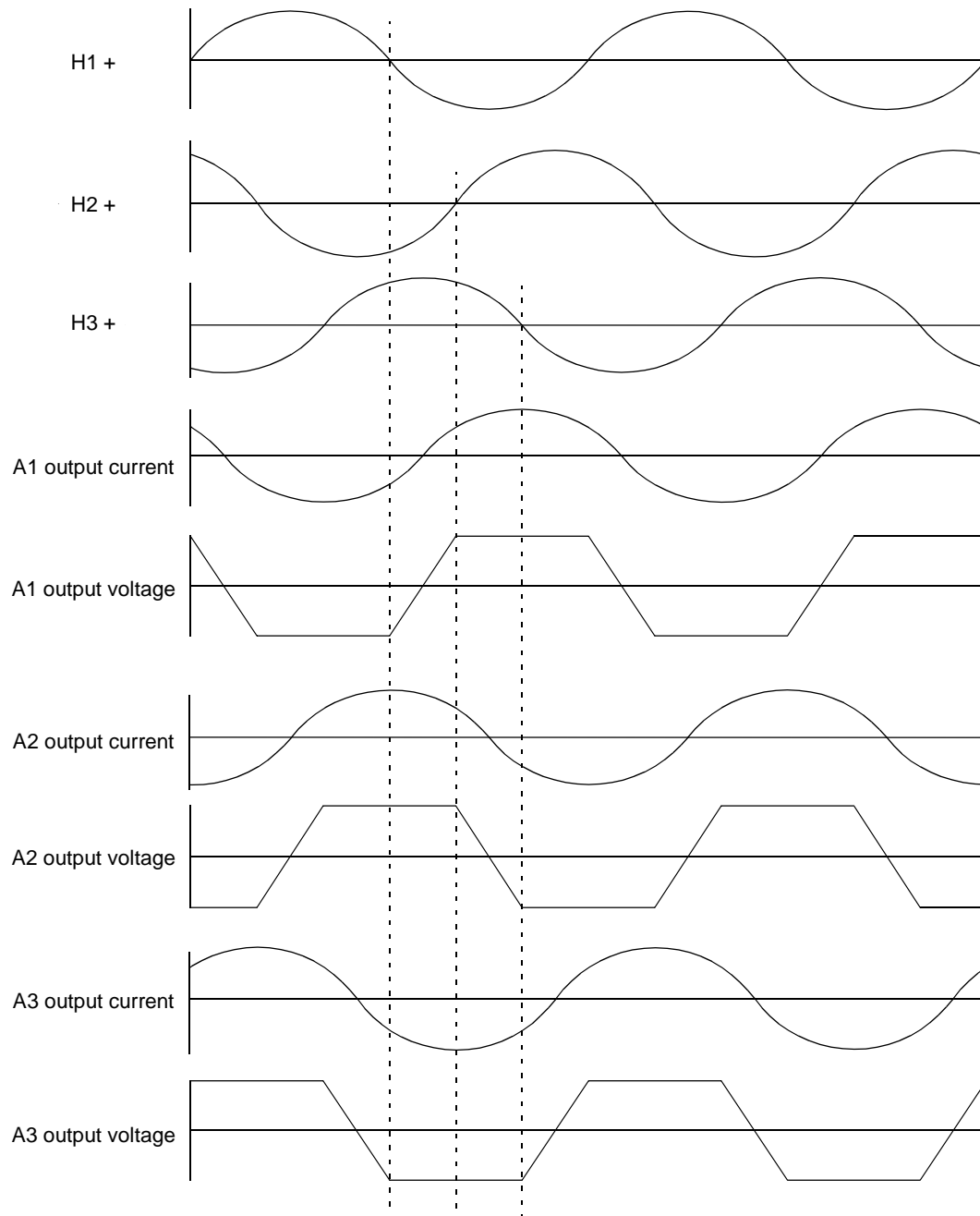

# Typical Performance Characteristics

## Total Circuit

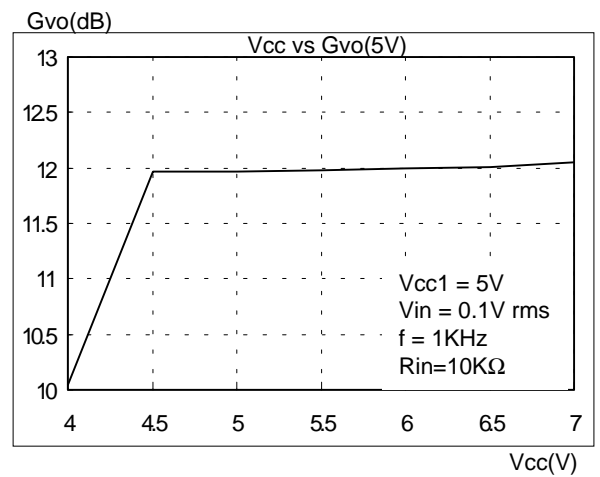
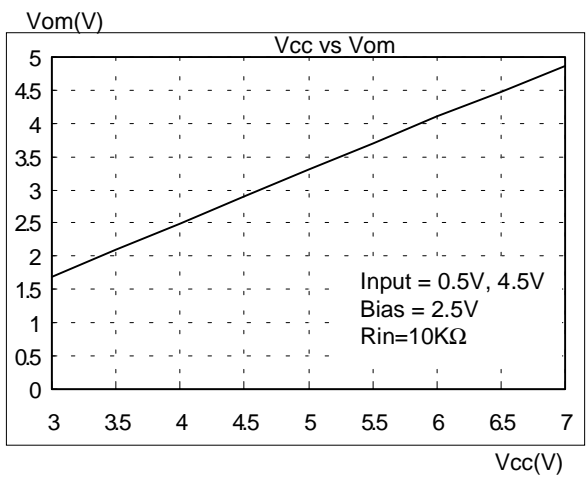
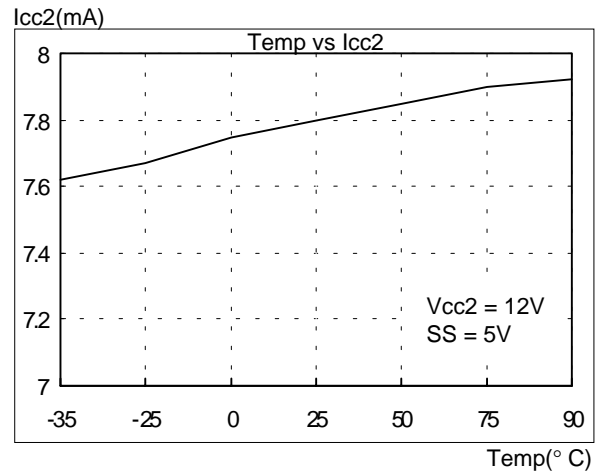
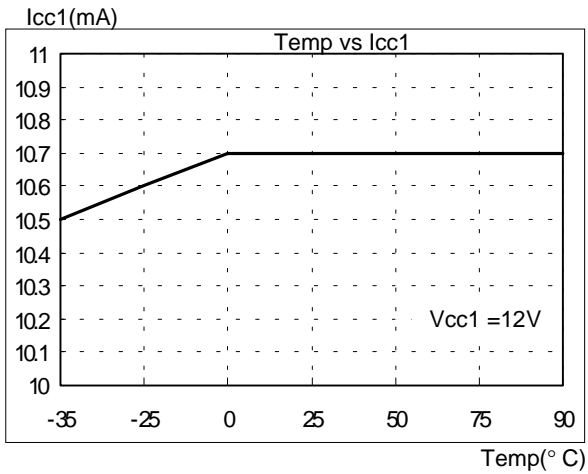
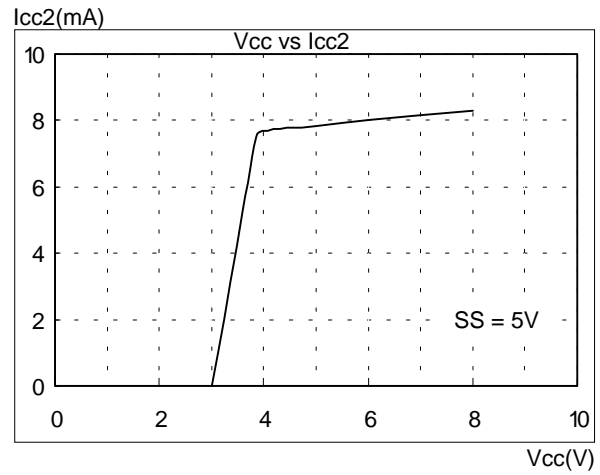
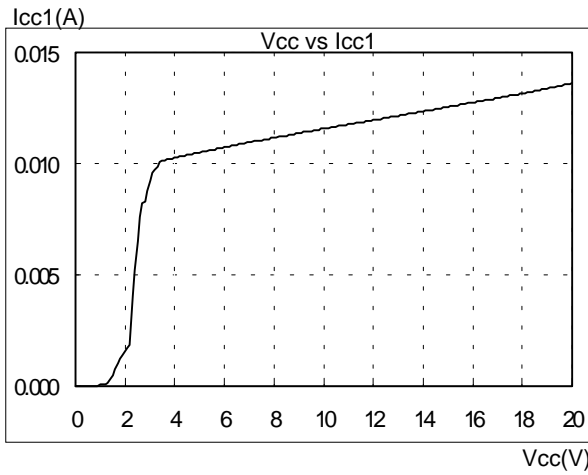

## Typical Performance Characteristics (Continued)

### Spindle Drive Part

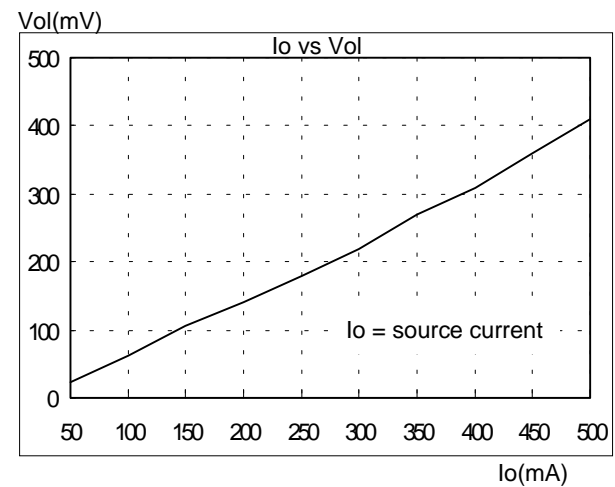
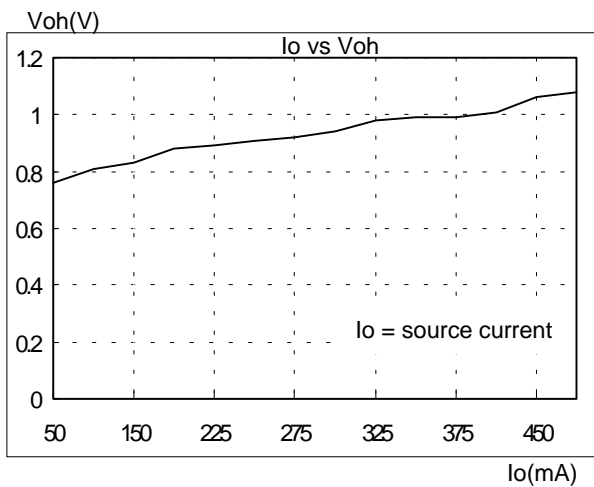
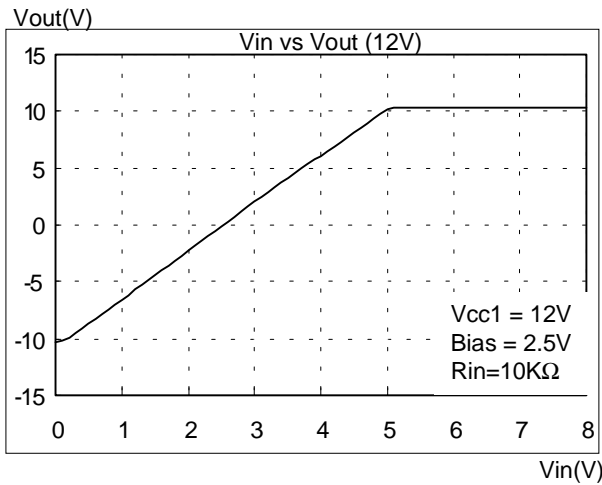
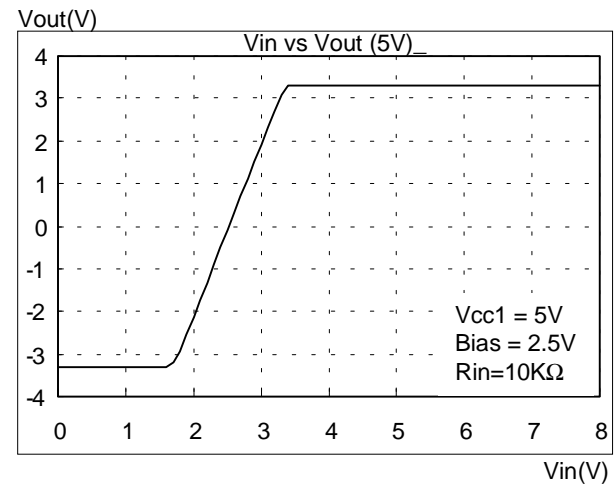
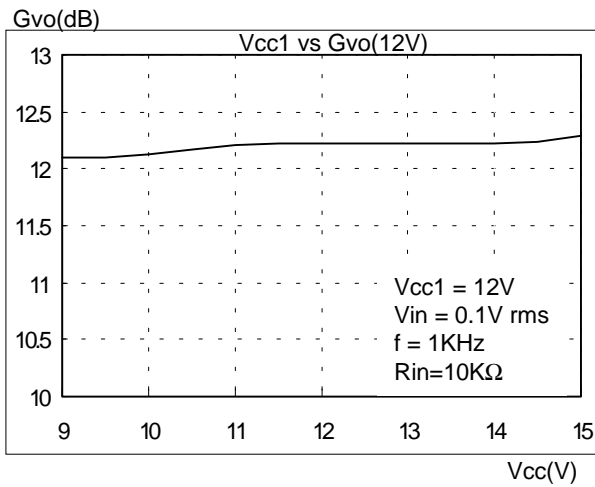

# Typical Performance Characteristics (Continued)

## OP AMP Part

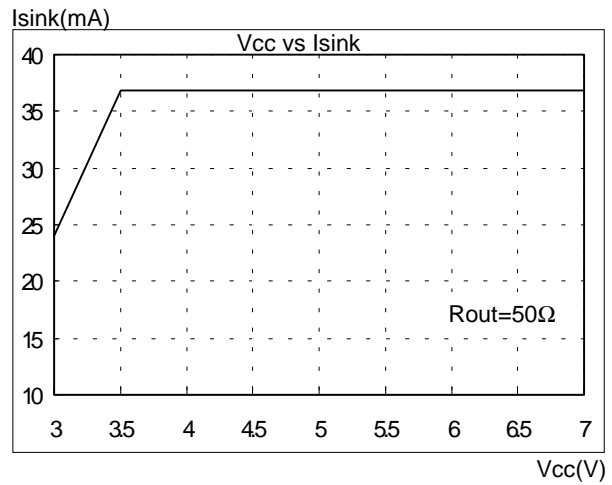
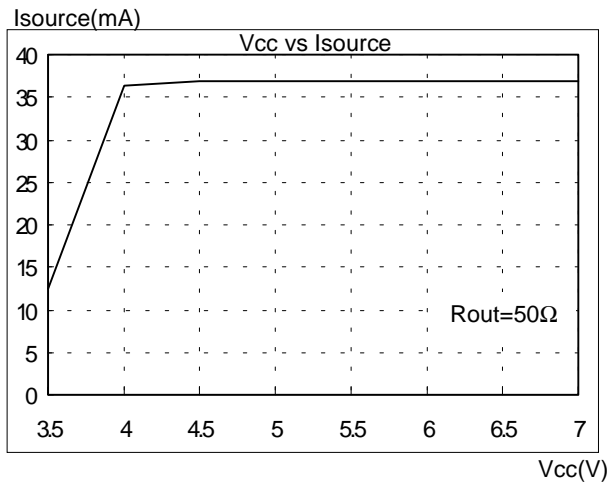
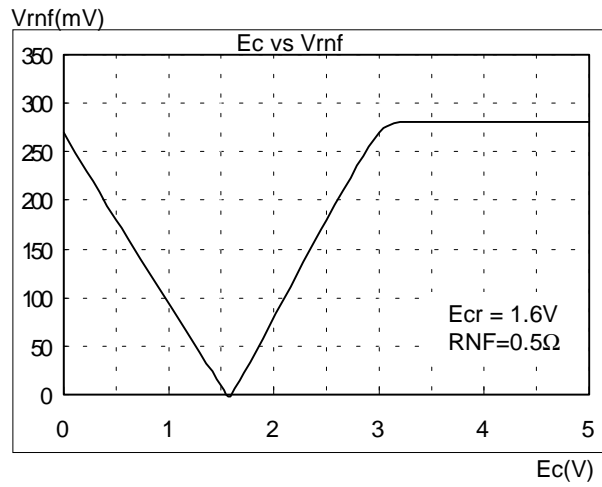
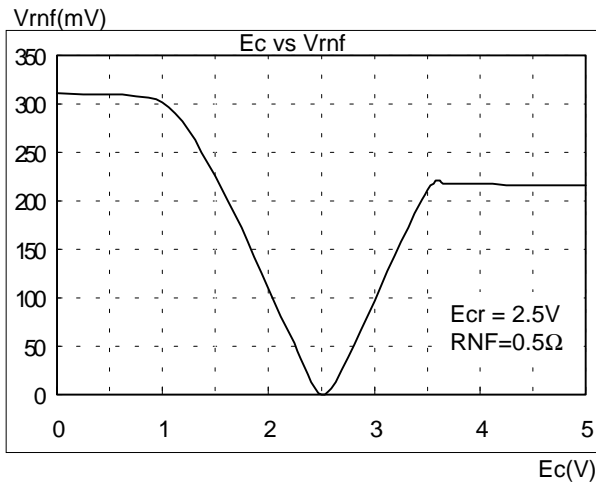

# Test Circuits 1

BTL Drive Part

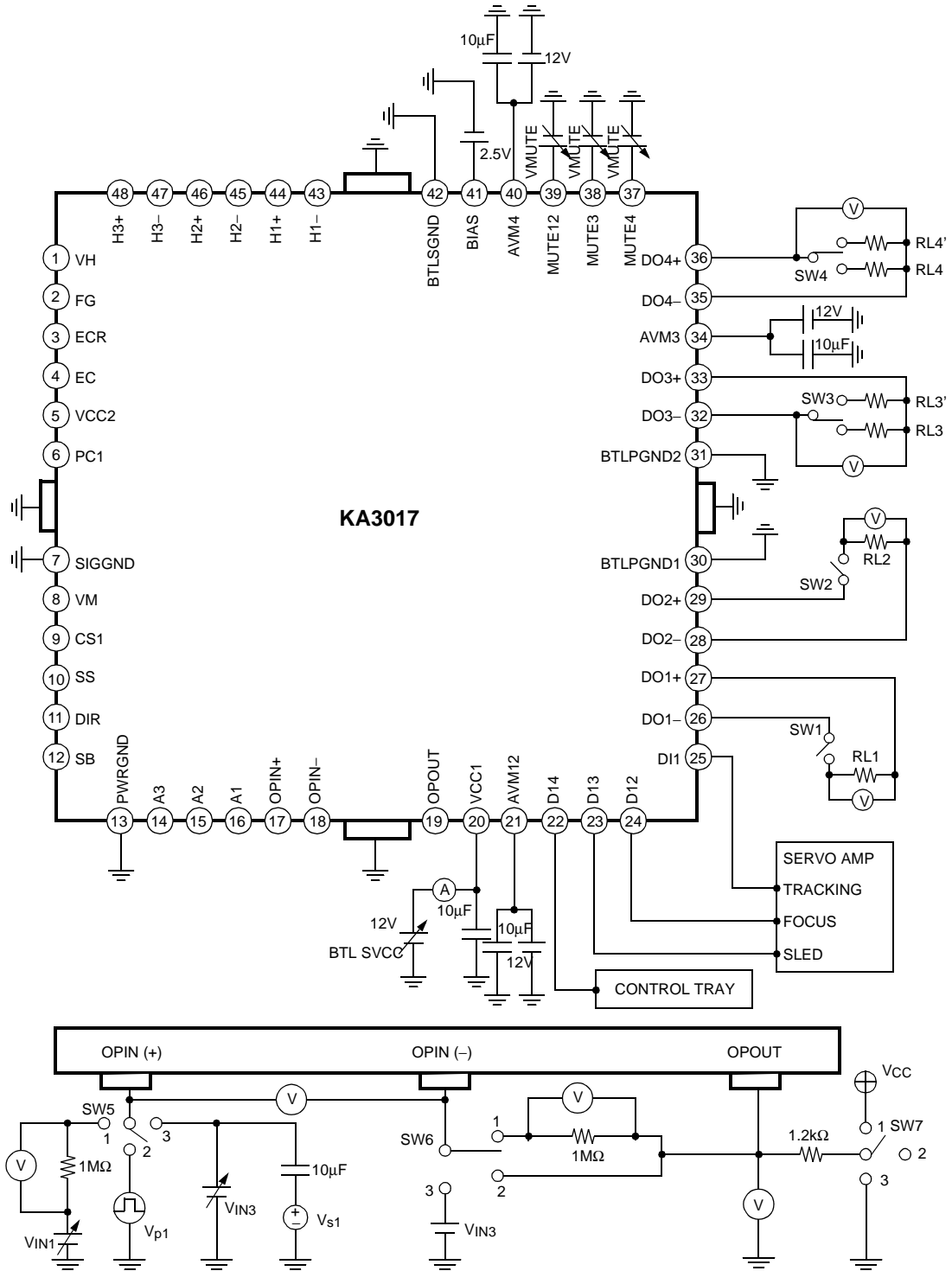

# Test Circuits 2

## Spindle Motor Drive Part

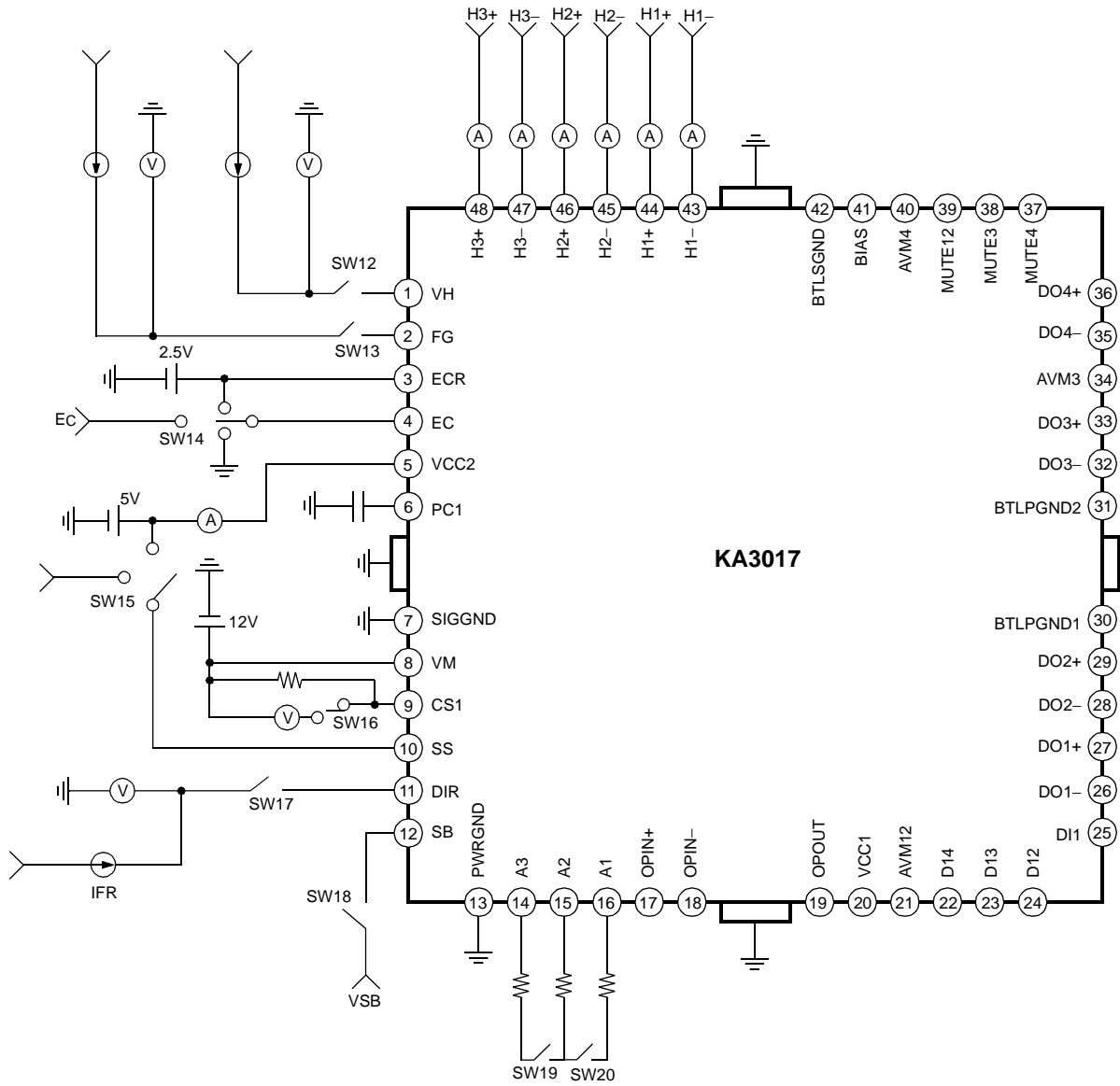



# Application Circuits

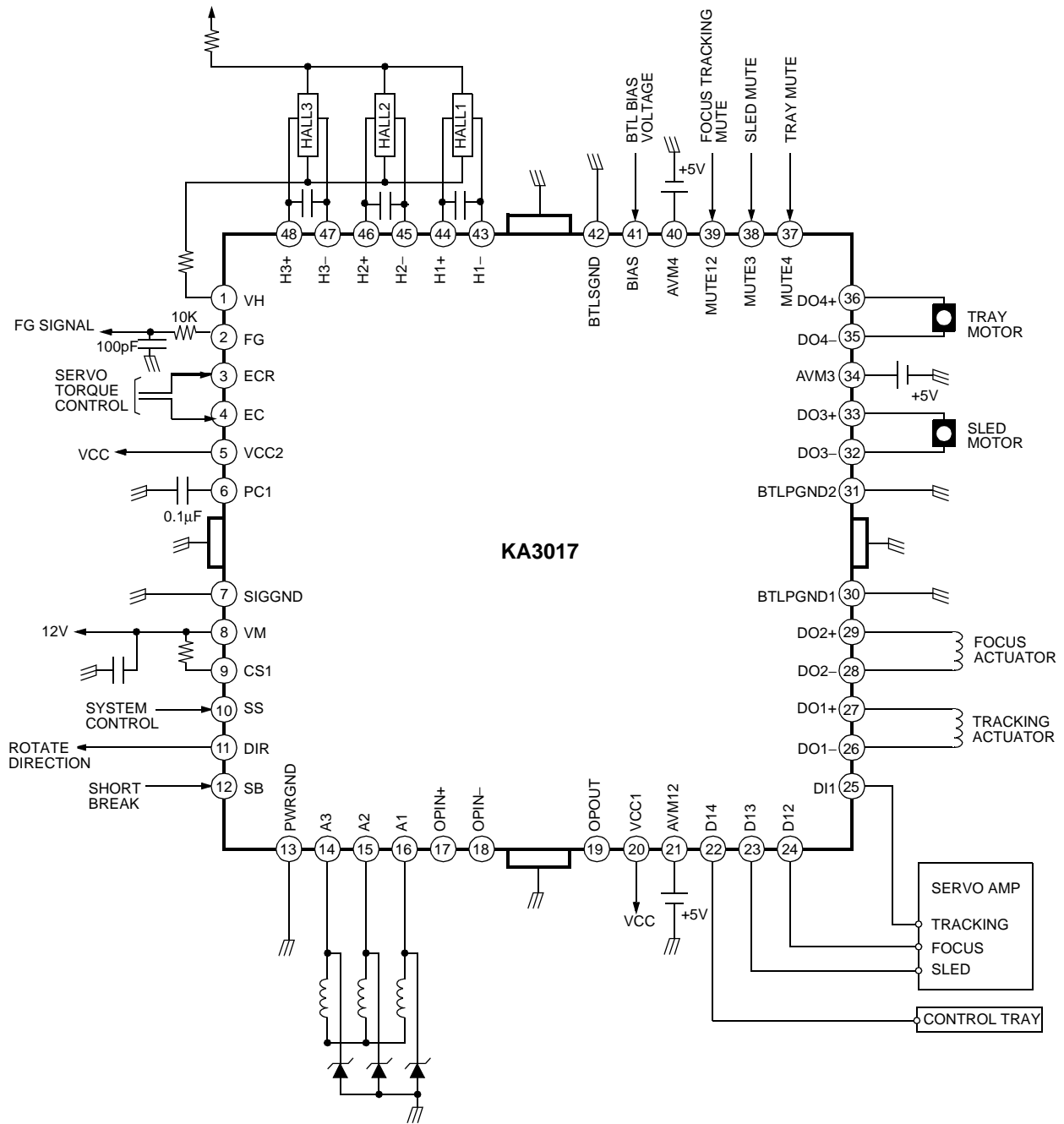

KA3017

**DISCLAIMER**

FAIRCHILD SEMICONDUCTOR RESERVES THE RIGHT TO MAKE CHANGES WITHOUT FURTHER NOTICE TO ANY PRODUCTS HEREIN TO IMPROVE RELIABILITY, FUNCTION OR DESIGN. FAIRCHILD DOES NOT ASSUME ANY LIABILITY ARISING OUT OF THE APPLICATION OR USE OF ANY PRODUCT OR CIRCUIT DESCRIBED HEREIN; NEITHER DOES IT CONVEY ANY LICENSE UNDER ITS PATENT RIGHTS, NOR THE RIGHTS OF OTHERS.

**LIFE SUPPORT POLICY**

FAIRCHILD'S PRODUCTS ARE NOT AUTHORIZED FOR USE AS CRITICAL COMPONENTS IN LIFE SUPPORT DEVICES OR SYSTEMS WITHOUT THE EXPRESS WRITTEN APPROVAL OF THE PRESIDENT OF FAIRCHILD SEMICONDUCTOR CORPORATION. As used herein:

1. Life support devices or systems are devices or systems which, (a) are intended for surgical implant into the body, or (b) support or sustain life, and (c) whose failure to perform when properly used in accordance with instructions for use provided in the labeling, can be reasonably expected to result in a significant injury of the user.
2. A critical component in any component of a life support device or system whose failure to perform can be reasonably expected to cause the failure of the life support device or system, or to affect its safety or effectiveness.