

# LM1815

## Adaptive Variable Reluctance Sensor Amplifier

### General Description

The LM1815 is an adaptive sense amplifier and default gating circuit for motor control applications. The sense amplifier provides a one-shot pulse output whose leading edge coincides with the negative-going zero crossing of a ground referenced input signal such as from a variable reluctance magnetic pick-up coil.

In normal operation, this timing reference signal is processed (delayed) externally and returned to the LM1815. A Logic input is then able to select either the timing reference or the processed signal for transmission to the output driver stage.

The adaptive sense amplifier operates with a positive-going threshold which is derived by peak detecting the incoming signal and dividing this down. Thus the input hysteresis varies with input signal amplitude. This enables the circuit to sense in situations where the high speed noise is greater than the low speed signal amplitude. Minimum input signal is 150mV<sub>P-P</sub>.

### Features

- Adaptive hysteresis
- Single supply operation
- Ground referenced input
- True zero crossing timing reference
- Operates from 2V to 12V supply voltage
- Handles inputs from 100 mV<sub>P-P</sub> to over 120V<sub>P-P</sub> with external resistor
- CMOS compatible logic

### Applications

- Position sensing with notched wheels
- Zero crossing switch
- Motor speed control
- Tachometer
- Engine testing

### Connection Diagram

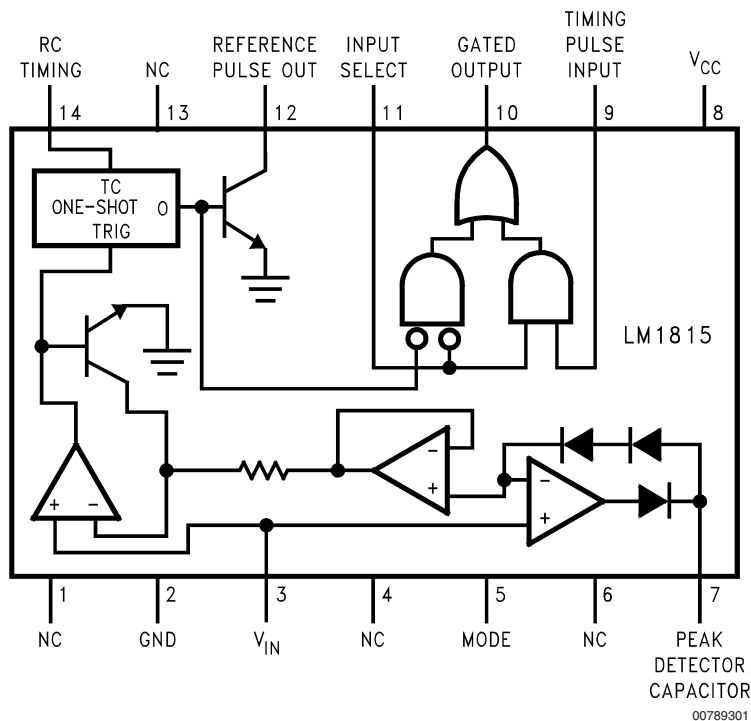

Top View

Order Number LM1815M or LM1815N  
See NS Package Number M14A or N14A

**Absolute Maximum Ratings** (Note 1)

If Military/Aerospace specified devices are required, please contact the National Semiconductor Sales Office/Distributors for availability and specifications.

Supply Voltage	12V
Power Dissipation (Note 2)	1250 mW
Operating Temperature Range	$-40^{\circ}\text{C} \leq T_A \leq +125^{\circ}\text{C}$

Storage Temperature Range	$-65^{\circ}\text{C} \leq T_J \leq +150^{\circ}\text{C}$
Junction Temperature	$+150^{\circ}\text{C}$
Input Current	$\pm 30\text{ mA}$
Lead Temperature (Soldering, 10 sec.)	$260^{\circ}\text{C}$

**Electrical Characteristics** ( $T_A = 25^{\circ}\text{C}$ ,  $V_{CC} = 10\text{V}$ , unless otherwise specified, see Figure 1)

Parameter	Conditions	Min	Typ	Max	Units
Operating Supply Voltage		2.5	10	12	V
Supply Current	Pin 3 = -0.1V, Pin 9 = 2V, Pin 11 = 0.8V		3.6	6	mA
Reference Pulse Width	$f_{IN} = 1\text{Hz to } 2\text{kHz}$ , $R = 150\text{k}\Omega$ , $C = 0.001\mu\text{F}$	70	100	130	$\mu\text{s}$
Logic Input Bias Current	$V_{IN} = 2\text{V}$ , (Pin 9 and Pin 11)			5	$\mu\text{A}$
Signal Input Bias Current	$V_{IN} = 0\text{V dc}$ , (Pin 3)		-200		nA
Logic Threshold	(Pin 9 and Pin 11)	0.8	1.1	2.0	V
$V_{OUT}$ High	$R_L = 1\text{k}\Omega$ , (Pin 10)	7.5	8.6		V
$V_{OUT}$ Low	$I_{SINK} = 0.1\text{mA}$ , (Pin 10)		0.3	0.4	V
Output Leakage Pin 12	$V_{12} = 11\text{V}$		0.01	10	$\mu\text{A}$
Saturation Voltage P12	$I_{12} = 2\text{mA}$		0.2	0.4	V
Input Zero Crossing Threshold	All Modes, $V_{SIGNAL} = 1\text{V pk-pk}$	-25	0	25	mV (Note 4)
Minimum Input Arming Threshold	Mode 1, Pin 5 = Open	30	45	60	mV (Note 4)
	Mode 2, Pin 5 = $V_{CC}$	200	300	450	mV (Note 4)
	Mode 3, Pin 5 = Gnd	-25	0	25	mV (Note 4)
Adaptive Input Arming Threshold	Mode 1, Pin 5 = Open $V_{SIGNAL} \geq 230\text{mV pk-pk}$ (Note 3)	40	80	90	% (Note 4)
	Mode 2, Pin 5 = $V_{CC}$ $V_{SIGNAL} \geq 1.0\text{V pk-pk}$ (Note 3)		80		% (Note 4)
	Mode 3, Pin 5 = Gnd $V_{SIGNAL} \geq 150\text{mV pk-pk}$ (Note 3)		80		% (Note 4)

**Note 1:** "Absolute Maximum Ratings" are those values beyond which the safety of the device cannot be guaranteed. They are not meant to imply that the devices should be operated at these limits. The table of "Electrical Characteristics" specifies conditions of device operation.

**Note 2:** For operation at elevated temperatures, the device must be derated based on a  $150^{\circ}\text{C}$  maximum junction temperature and a thermal resistance of  $80^{\circ}\text{C/W}$  (DIP),  $120^{\circ}\text{C/W}$  (SO-14) junction to ambient.

**Note 3:** Tested per Figure 1,  $V_{SIGNAL}$  is a Sine Wave;  $F_{SIGNAL}$  is 1000Hz.

**Note 4:** The Min/Typ Max limits are relative to the positive voltage peak seen at  $V_{IN}$  Pin 3.

# Typical Performance Characteristics

**Mode 1 Minimum Arming Threshold vs Temperature**

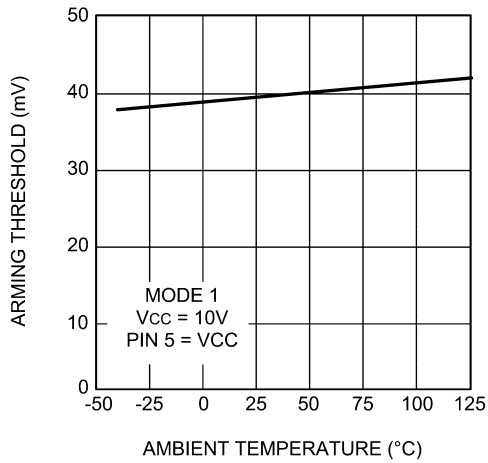

00789305

**Mode 2 Minimum Arming Threshold vs Temperature**

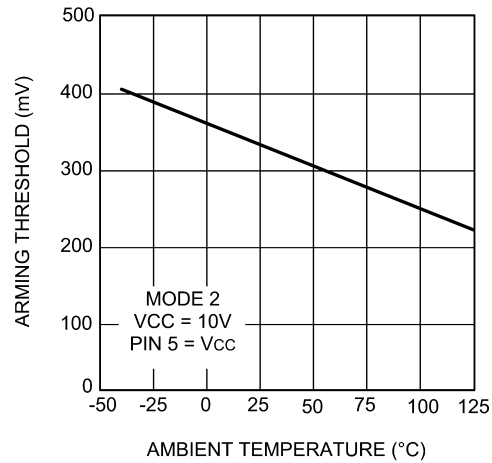

00789306

**Mode 3 Minimum Arming Threshold vs Temperature**

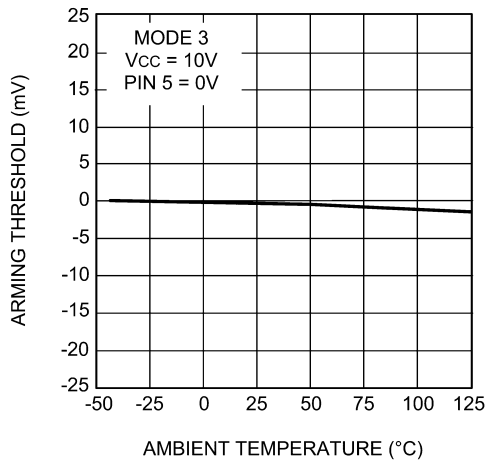

00789307

**Mode 1 Minimum Arming Threshold vs V<sub>CC</sub>**

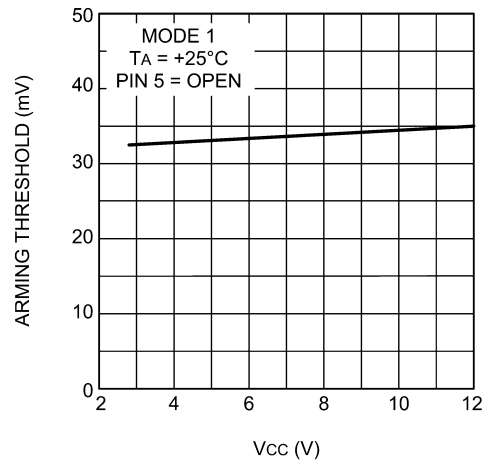

00789308

**Mode 2 Minimum Arming Threshold vs V<sub>CC</sub>**

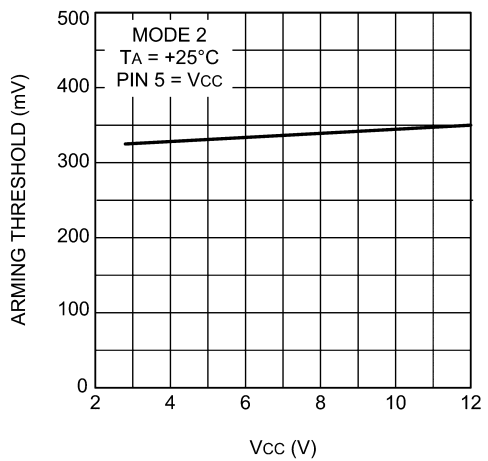

00789309

**Pin 3 V<sub>IN</sub> vs V<sub>SIGNAL</sub>**

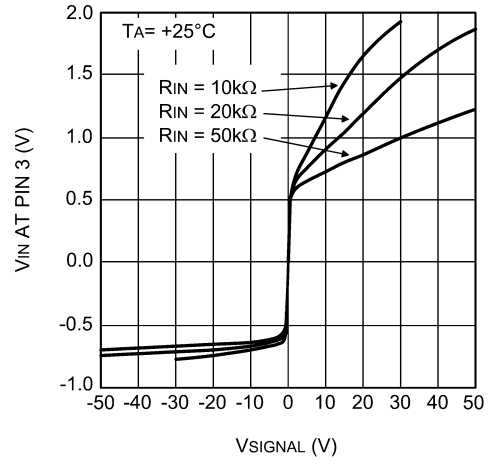

00789310

Typical Performance Characteristics (Continued)

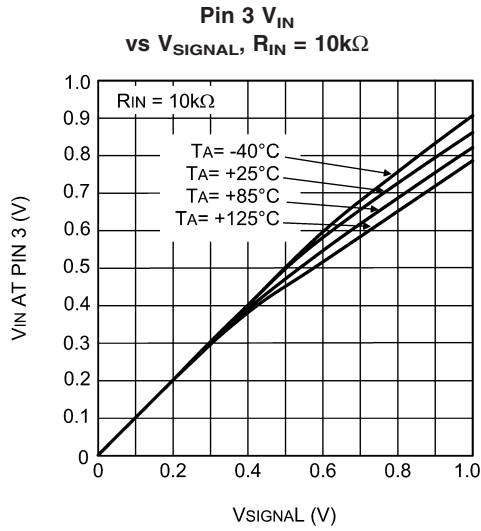

00789311

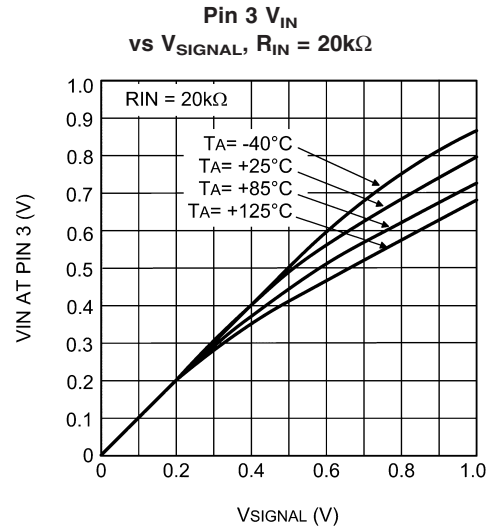

00789312

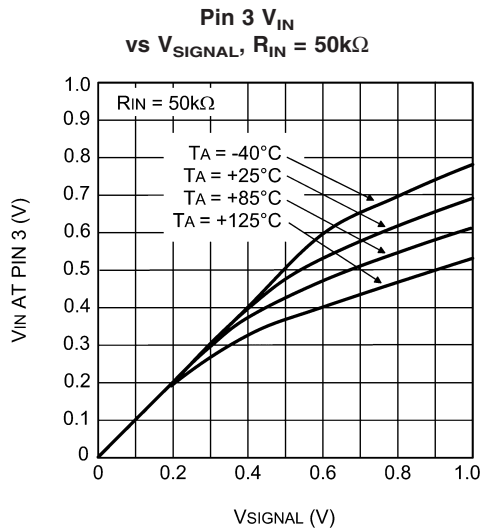

00789313

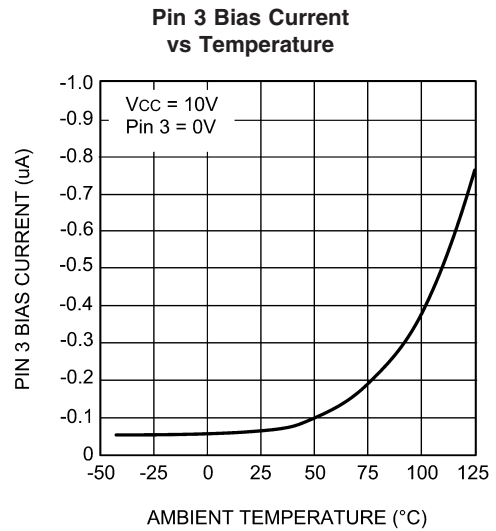

00789314

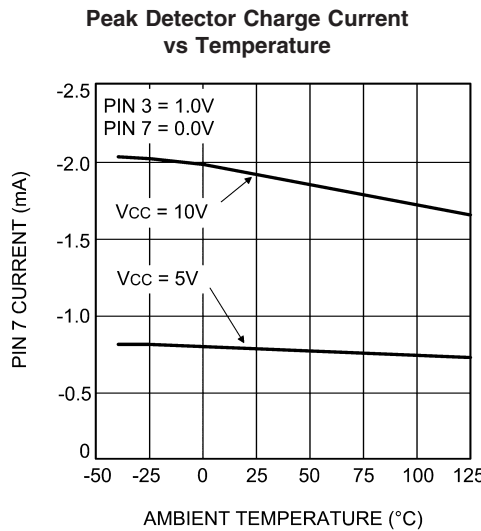

00789315

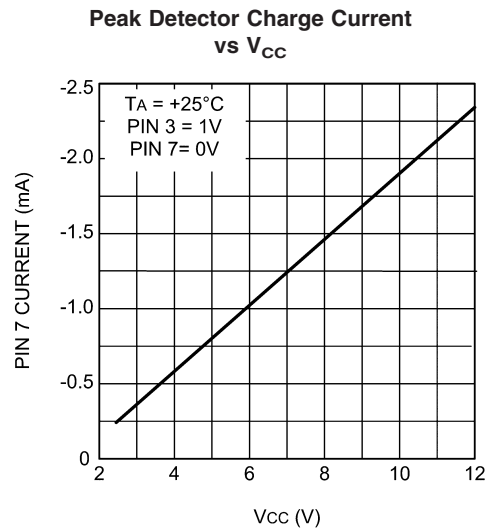

00789316

## Typical Performance Characteristics (Continued)

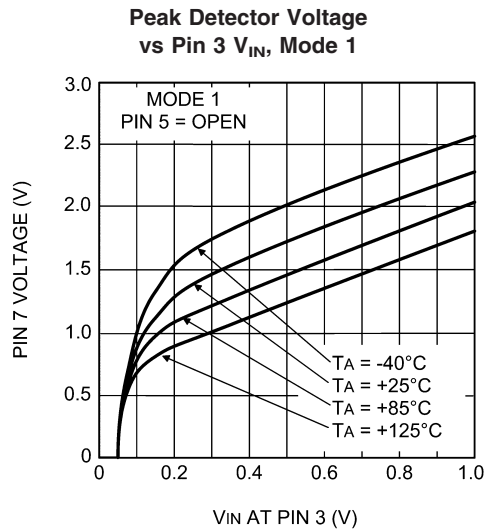

00789317

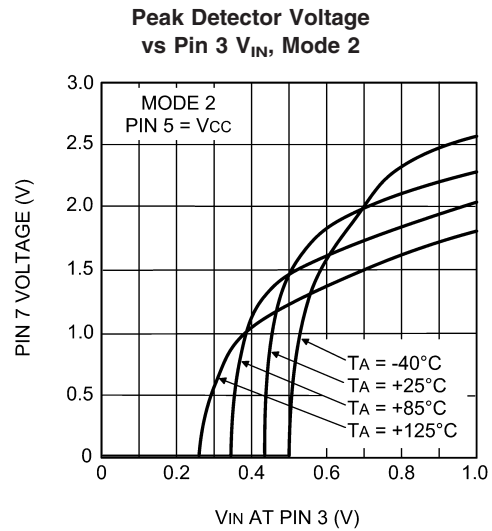

00789318

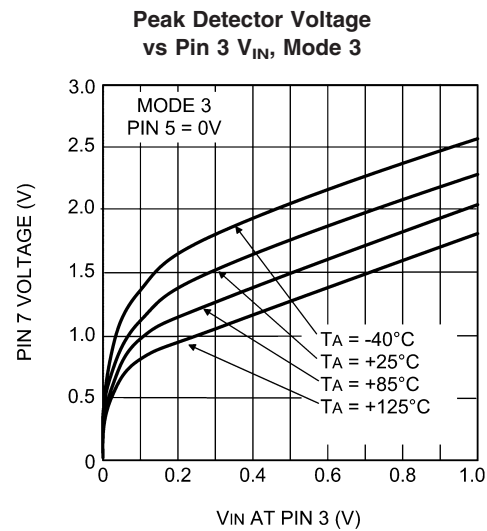

00789319

# Truth Table

Signal Input Pin 3	RC Timing Pin 14	Input Select Pin 11	Timing Input Pin 9	Gated Output Pin 10
± Pulses	RC	L	X	Pulses = RC
X	X	H	H	H
X	X	H	L	L
± Pulses	L	L	L	Zero Crossing

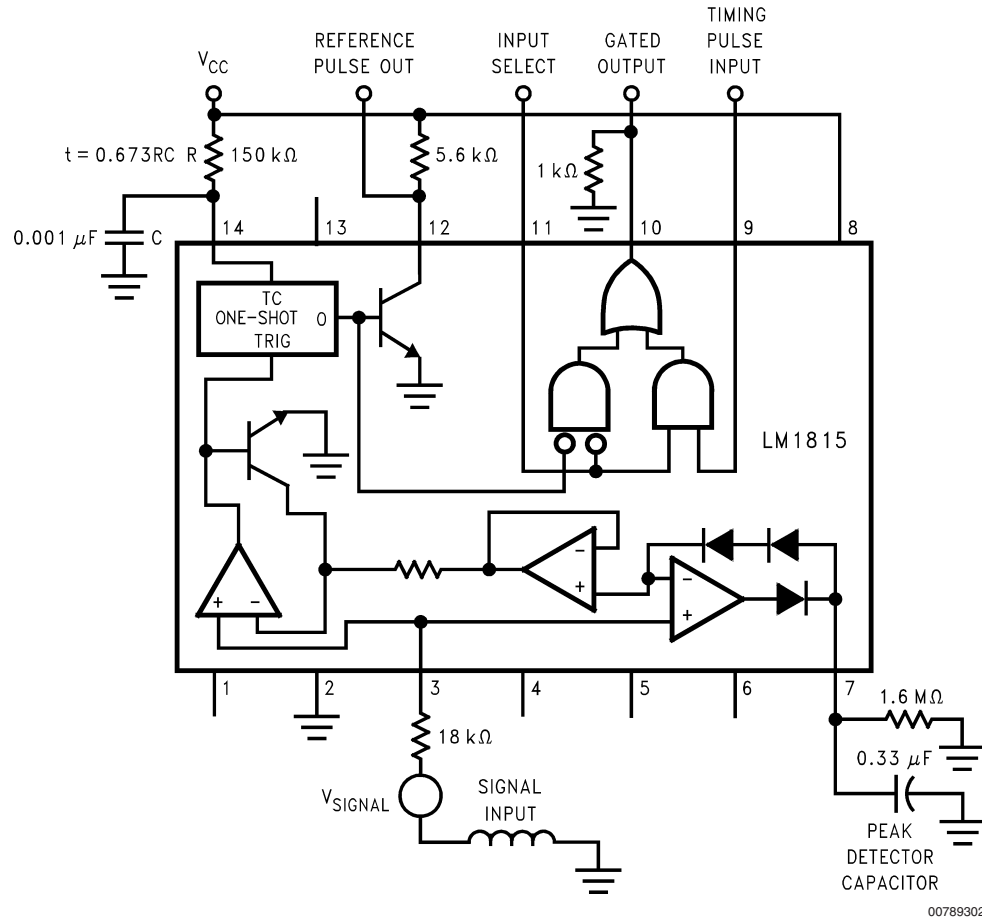
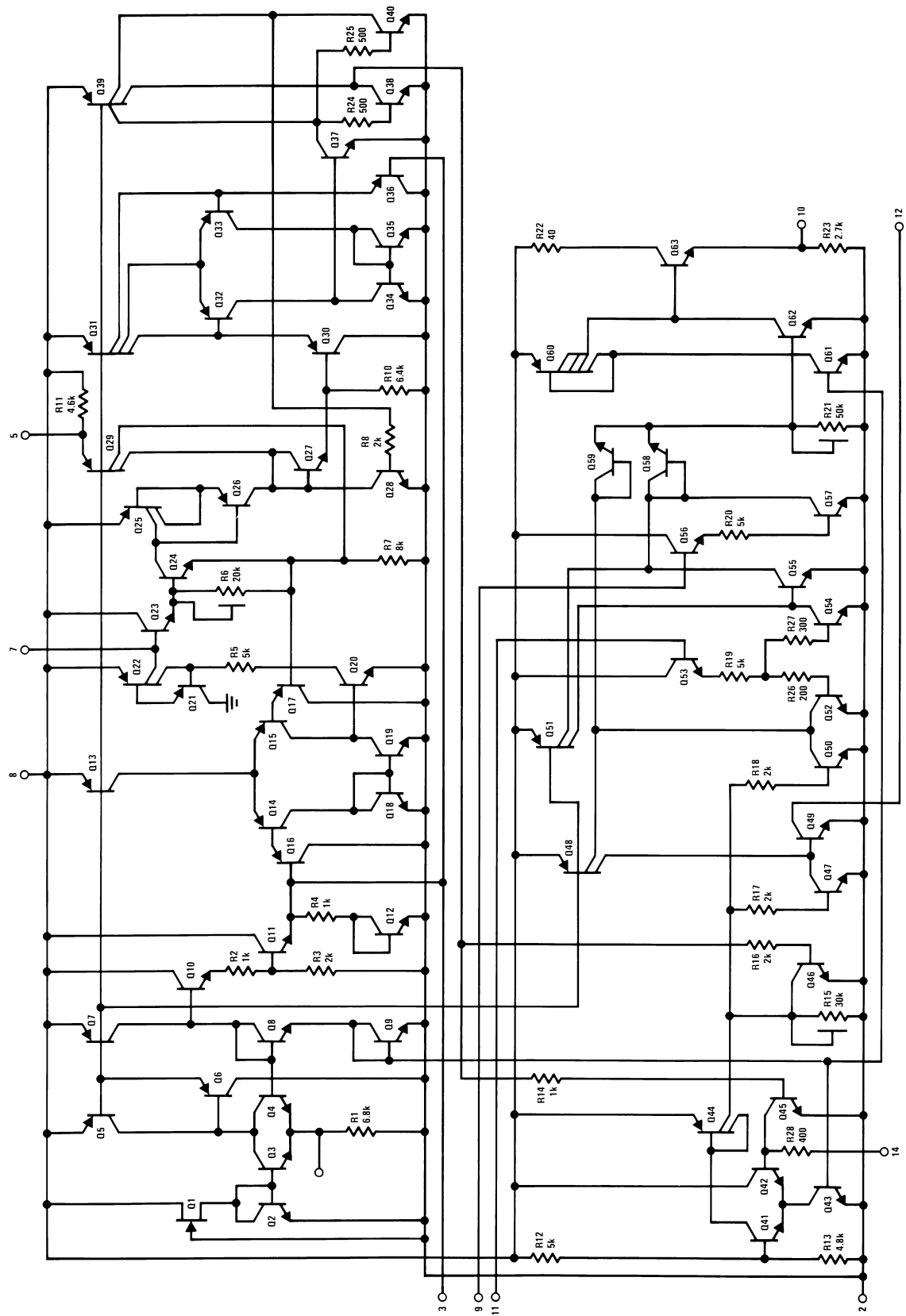

FIGURE 1. LM1815 Adaptive Sense Amplifier

# Schematic Diagram



00789804

LM1815

## Application Hints

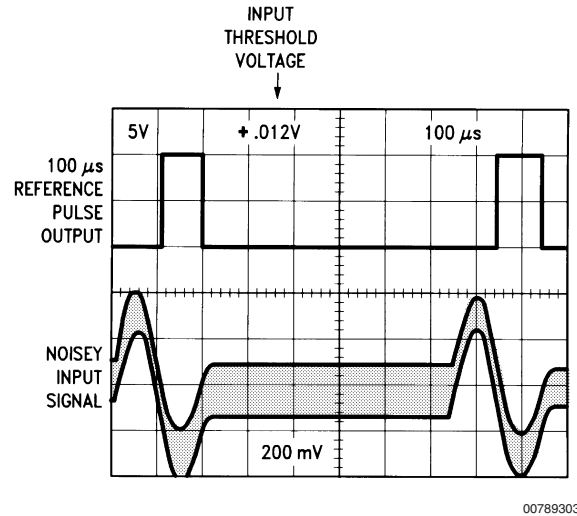

FIGURE 2. LM1815 Oscilloscopes

### INPUT VOLTAGE CLAMP

The signal input voltage at pin 3 is internally clamped. Current limit for the Input pin is provided by an external resistor which should be selected to allow a peak current of  $\pm 3$  mA in normal operation. Positive inputs are clamped by a  $1\text{k}\Omega$  resistor and series diode (see R4 and Q12 in the internal schematic diagram), while an active clamp limits pin 3 to typically  $350\text{mV}$  below Ground for negative inputs (see R2, R3, Q10, and Q11 in the internal schematic diagram). Thus for input signal transitions that are more than  $350\text{mV}$  below Ground, the input pin current (up to  $3\text{mA}$ ) will be pulled from the V+ supply. If the V+ pin is not adequately bypassed the resulting voltage ripple at the V+ pin will disrupt normal device operation. Likewise, for input signal transitions that are more than  $500\text{mV}$  above Ground, the input pin current will be dumped to Ground through device pin 2. Slight shifts in the Ground potential at device pin 2, due to poor grounding techniques relative to the input signal ground, can cause unreliable operation. As always, adequate device grounding, and V+ bypassing, needs to be considered across the entire input voltage and frequency range for the intended application.

### INPUT CURRENT LIMITING

As stated earlier, current limiting for the Input pin is provided by a user supplied external resistor. For purposes of selecting the appropriate resistor value the Input pin should be considered to be a zero ohm connection to ground. For applications where the input voltage signal is not symmetrical with relationship to Ground the worst case voltage peak should be used.

$$\text{Minimum } R_{\text{ext}} = [(V_{\text{in peak}})/3\text{mA}]$$

In the application example shown in figure 1 ( $R_{\text{ext}} = 18\text{k}\Omega$ ) the recommended maximum input signal voltage is  $\pm 54\text{V}$  (i.e.  $108\text{Vp-p}$ ).

### OPERATION OF ZERO CROSSING DETECTOR

The LM1815 is designed to operate as a zero crossing detector, triggering an internal one shot on the negative-going edge of the input signal. Unlike other zero crossing

detectors, the LM1815 cannot be triggered until the input signal has crossed an "arming" threshold on the positive-going portion of the waveform. The arming circuit is reset when the chip is triggered, and subsequent zero crossings are ignored until the arming threshold is exceeded again. This threshold varies depending on the connection at pin 5. Three different modes of operation are possible:

#### MODE 1, PIN 5 OPEN

The adaptive mode is selected by leaving device pin 5 open circuit. For input signals of less than  $\pm 135\text{mV}$  (i.e.  $270\text{mVp-p}$ ) and greater than typically  $\pm 75\text{mV}$  (i.e.  $150\text{mVp-p}$ ), the input arming threshold is typically at  $45\text{mV}$ . Under these conditions the input signal must first cross the  $45\text{mV}$  threshold in the positive direction to arm the zero crossing detector, and then cross zero in the negative direction to trigger it.

If the signal is less than  $30\text{mV}$  peak (minimum rating in Electrical Characteristics), the one shot is guaranteed to not trigger.

Input signals of greater than  $\pm 230\text{mV}$  (i.e.  $460\text{mVp-p}$ ) will cause the arming threshold to track at 80% of the peak input voltage. A peak detector capacitor at device pin 7 stores a value relative to the positive input peaks to establish the arming threshold. Input signals must exceed this threshold in the positive direction to arm the zero crossing detector, which can then be triggered by a negative-going zero crossing.

The peak detector tracks rapidly as the input signal amplitude increases, and decays by virtue of the resistor connected externally at pin 7 track decreases in the input signal.

If the input signal amplitude falls faster than the voltage stored on the peak detector capacitor there may be a loss of output signal until the capacitor voltage has decayed to an appropriate level.

Note that since the input voltage is clamped, the waveform observed at pin 3 is not identical to the waveform observed at the variable reluctance sensor. Similarly, the voltage stored at pin 7 is not identical to the peak voltage appearing at pin 3.



## Application Hints (Continued)

### MODE 2, PIN 5 CONNECTED TO V+

The input arming threshold is fixed at 200mV minimum when device pin 5 is connected to the positive supply. The chip has no output for signals of less than  $\pm 200$  mV (i.e. 400mVp-p) and triggers on the next negative-going zero crossing when the arming threshold is has been exceeded.

### MODE 3, PIN 5 GROUNDED

With pin 5 grounded, the input arming threshold is set to 0V,  $\pm 25$ mV maximum. Positive-going zero crossings arm the chip, and the next negative-going zero crossing triggers it. This is the very basic form of zero-crossing detection.

### ONE SHOT TIMING

The one shot timing is set by a resistor and capacitor connected to pin 14. The recommended maximum resistor value is 150kohms. The capacitor value can be changed as needed, as long as the capacitor type does not present any significant leakage that would adversely affect the RC time constant.

The output pulse width is:

$$\text{pulse width} = 0.673 \times R \times C \quad (1)$$

For a given One Shot pulse width, the recommended maximum input signal frequency is:

$$F_{in}(\text{max}) = 1/(1.346 \times R \times C) \quad (2)$$

In the application example shown in figure 1 (R=150kohms, C=0.001 $\mu$ F) the recommended maximum input frequency will typically be 5kHz. Operating with input frequencies above the recommended  $F_{in}(\text{max})$  value may result in unreliable performance of the One Shot circuitry. For those applications where the One Shot circuit is not required, device pin 14 can be tied directly to Ground.

### LOGIC INPUTS

In some systems it is necessary to externally generate pulses, such as during stall conditions when the variable reluctance sensor has no output. External pulse inputs at pin 9 are gated through to pin 10 when Input Select (pin 11) is pulled high. Pin 12 is a direct output for the one shot and is unaffected by the status of pin 11.

Input/output pins 9, 11, 10, and 12 are all CMOS logic compatible. In addition, pins 9, 11, and 12 are TTL compatible. Pin 10 is not guaranteed to drive a TTL load.

Pins 1, 4, 6 and 13 have no internal connections and can be grounded.

**Physical Dimensions** inches (millimeters)

unless otherwise noted

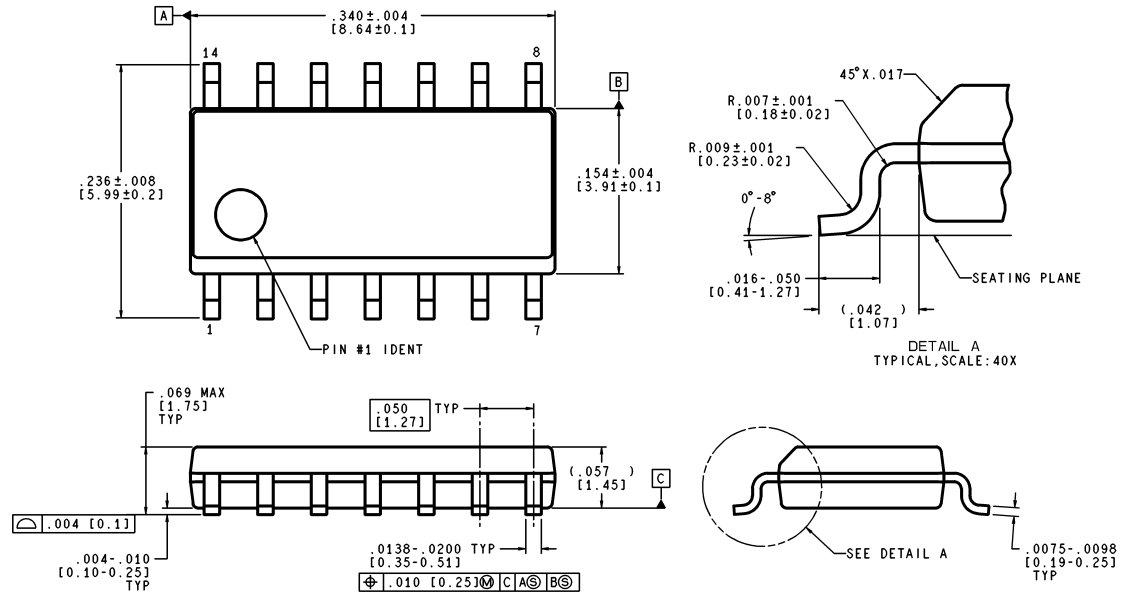

**14-Lead Small Outline Circuit (M)**  
**Order Number LM1815M**  
**NS Package Number M14A**

**Physical Dimensions** inches (millimeters) unless otherwise noted (Continued)

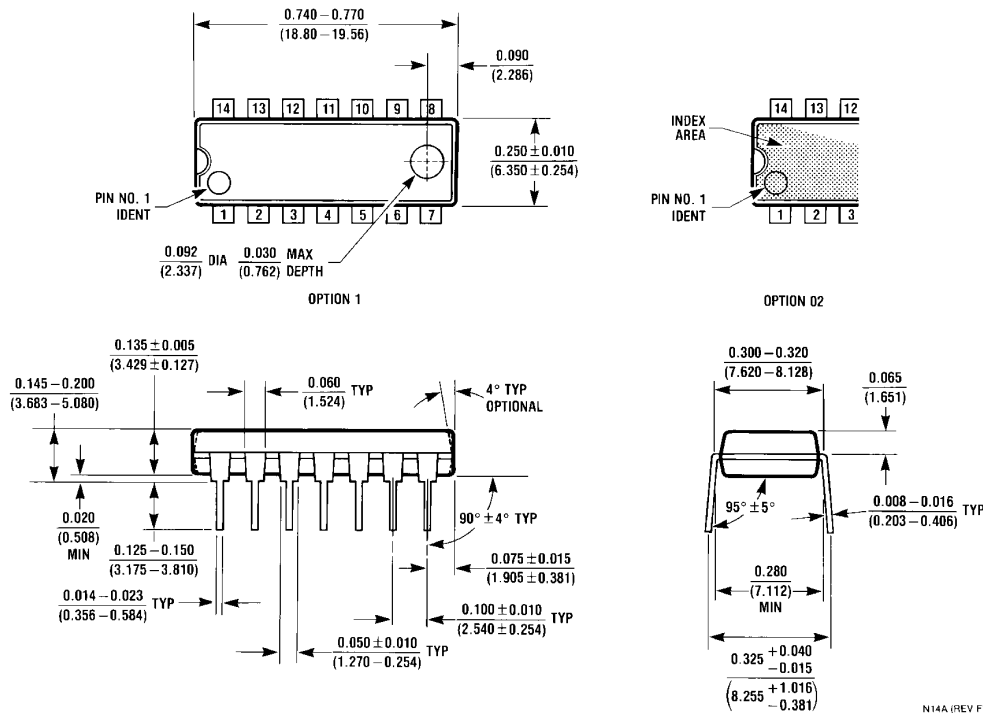

**Molded Dual-In-Line Package (N)**  
**Order Number LM1815N**  
**NS Package Number N14A**

N14A (REV F)

National does not assume any responsibility for use of any circuitry described, no circuit patent licenses are implied and National reserves the right at any time without notice to change said circuitry and specifications.

For the most current product information visit us at [www.national.com](http://www.national.com).

**LIFE SUPPORT POLICY**

NATIONAL'S PRODUCTS ARE NOT AUTHORIZED FOR USE AS CRITICAL COMPONENTS IN LIFE SUPPORT DEVICES OR SYSTEMS WITHOUT THE EXPRESS WRITTEN APPROVAL OF THE PRESIDENT AND GENERAL COUNSEL OF NATIONAL SEMICONDUCTOR CORPORATION. As used herein:

1. Life support devices or systems are devices or systems which, (a) are intended for surgical implant into the body, or (b) support or sustain life, and whose failure to perform when properly used in accordance with instructions for use provided in the labeling, can be reasonably expected to result in a significant injury to the user.
2. A critical component is any component of a life support device or system whose failure to perform can be reasonably expected to cause the failure of the life support device or system, or to affect its safety or effectiveness.

**BANNED SUBSTANCE COMPLIANCE**

National Semiconductor manufactures products and uses packing materials that meet the provisions of the Customer Products Stewardship Specification (CSP-9-111C2) and the Banned Substances and Materials of Interest Specification (CSP-9-111S2) and contain no "Banned Substances" as defined in CSP-9-111S2.

**National Semiconductor**  
**Americas Customer Support Center**  
 Email: [new.feedback@nsc.com](mailto:new.feedback@nsc.com)  
 Tel: 1-800-272-9959

**National Semiconductor**  
**Europe Customer Support Center**  
 Fax: +49 (0) 180-530 85 86  
 Email: [europe.support@nsc.com](mailto:europe.support@nsc.com)  
 Deutsch Tel: +49 (0) 69 9508 6208  
 English Tel: +44 (0) 870 24 0 2171  
 Français Tel: +33 (0) 1 41 91 8790

**National Semiconductor**  
**Asia Pacific Customer Support Center**  
 Email: [ap.support@nsc.com](mailto:ap.support@nsc.com)

**National Semiconductor**  
**Japan Customer Support Center**  
 Fax: 81-3-5639-7507  
 Email: [jpn.feedback@nsc.com](mailto:jpn.feedback@nsc.com)  
 Tel: 81-3-5639-7560

[www.national.com](http://www.national.com)