

RGB SWITCHING CIRCUIT

- 25MHz BANDWIDTH
- CROSSTALK : 55dB
- SHORT CIRCUIT TO GROUND OR V_{CC} PROTECTED
- ANTI SATURATION GAIN CHANGING
- VIDEO SWITCHING

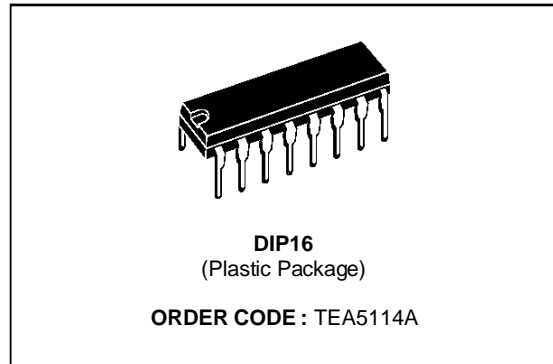

DESCRIPTION

This integrated circuit provides RGB switching allowing connections between peri TV plug, internal RGB generator and video processor in a TV set.

The input signal black level is tied to the same reference voltage on each input in order to have no differential voltage when switching two RGB generators.

An AC output signal higher than 2 Vpp makes gain going slowly down to 0dB to protect the TV set video amplifier from saturation.

Fast blanking output is a logical OR between FB1 (Pin 8) and FB2 (Pin 10).

PIN CONNECTIONS

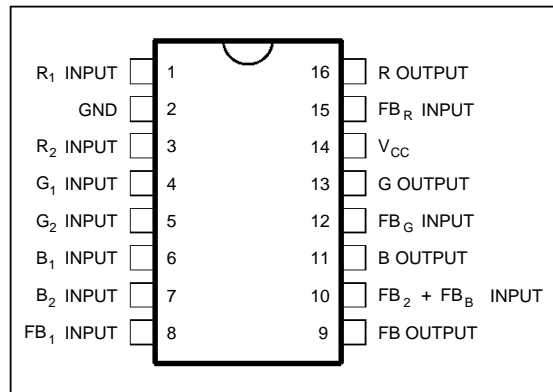

5114A-01.EPS

BLOCK DIAGRAM

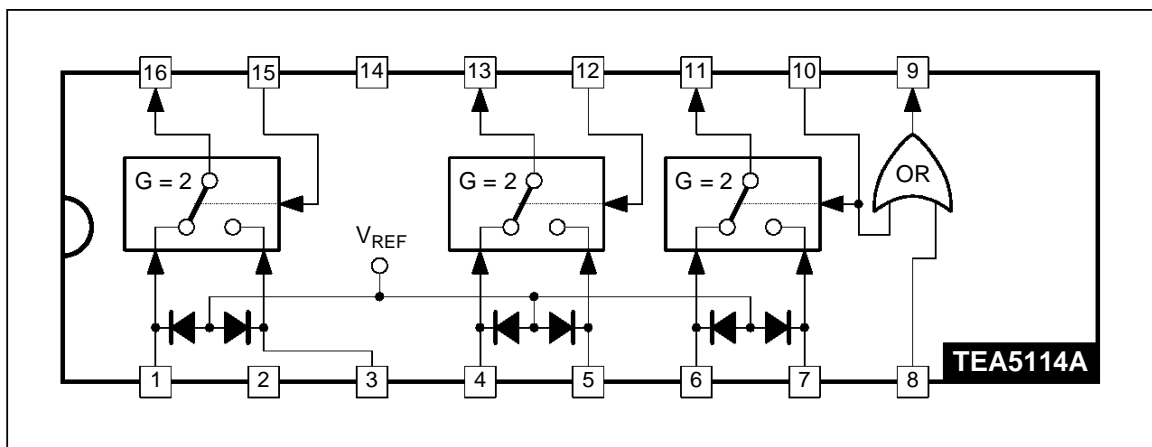

5114A-02.EPS

ABSOLUTE MAXIMUM RATINGS

Symbol	Parameter	Value	Unit
V_{CC}	Supply Voltage	18	V
T_j	Junction Temperature	- 40 to 150	°C
T_{stg}	Storage Temperature	- 40 to 150	°C
Z_L	Minimum Load Resistor on Each Output	$V_{CC} = 12\text{ V}$ 300 $V_{CC} = 10\text{ V}$ 150	Ω Ω
T_{amb}	Operating Ambient Temperature	0 to 70	°C

5114A-01.TBL

THERMAL DATA

Symbol	Parameter	Value	Unit
$R_{th(j-a)}$	Junction-ambient Thermal Resistance	80	°C/W

5114A-02.TBL

ELECTRICAL OPERATING CHARACTERISTICS

 $T_{amb} = 25\text{ °C}$, $V_{CC} = 12\text{ V}$, $Z_L\text{ (RGB)} = 300\ \Omega$ $V_{CC} = 10\text{ V}$, $Z_L\text{ (RGB)} = 150\ \Omega$ (unless otherwise specified)

Symbol	Parameter	Min.	Typ.	Max.	Unit
V_{CC}	Supply Voltage	9	12	13.2	V
I_{CC}	Supply Current without Load $V_{CC} = 12\text{ V}$	20	30	40	mA
V_{ON}	Black Level Output Voltage (on pins 11, 13, 16 square wave output signal 1 kHz - 1 Vpp) $T_j = 25\text{ °C}$ (5mV/°C typical variation)	1.8	2.5	2.9	V
G_{RGB}	Gain of Each Channel Pins 11, 13, 16 $F = 1\text{ MHz}$, $V_{in} = 0.5\text{ V}_{pp}$	5	5.5	6	dB
B_{RGB}	Bandwidth (- 3 dB) $V_O = 1\text{ V}_{pp}$	18	22		MHz
V_{GC}	Threshold Output Voltage for Gain Changing (- 0.5 dB)	2			V_{pp}
V_R	Video Rejection between Two Inputs R, G or B $F = 1\text{ MHz}$ Sinus $V_O = 1\text{ V}_{pp}$	50	55		dB
Z_{IRGB}	Input Impedance on Pins 1, 3, 4, 5, 6, 7 $V_O = 1\text{ V}_{pp}$	10			k Ω
Z_{ORGB}	R, G, B Output Impedance on Pins 11, 13, 16			15	Ω
T_{FB}	FB rising and falling time on pin 9. 1 Vpp Input Voltage Pins 8, 10		20		ns
V_{IHFB}	FB High Level Input Voltage on Pins 8, 10, 12, 15	1		4	V
V_{ILFB}	FB Low Level Input Voltage on Pins 8, 10, 12, 15	0		0.4	V
Z_{IFB}	Input Impedance on Pins 8, 10, 12, 15	0.7	1	1.3	k Ω
V_{OHFB}	High Level FB Output Voltage (pin 9) Input 1 V on Pins 8, 10	0.8	1	1.2	V
V_{OLFB}	Low Level FB Output (pin 9) Input 0 V on Pins 8, 10			0.3	V
Z_{OFB}	FB Output Impedance Pin 9 High Level			30	Ω
T_{dFBRGB}	Delay Time between FB Inputs and R, G, B Switching		20		ns

5114A-03.TBL

TEST DIAGRAM

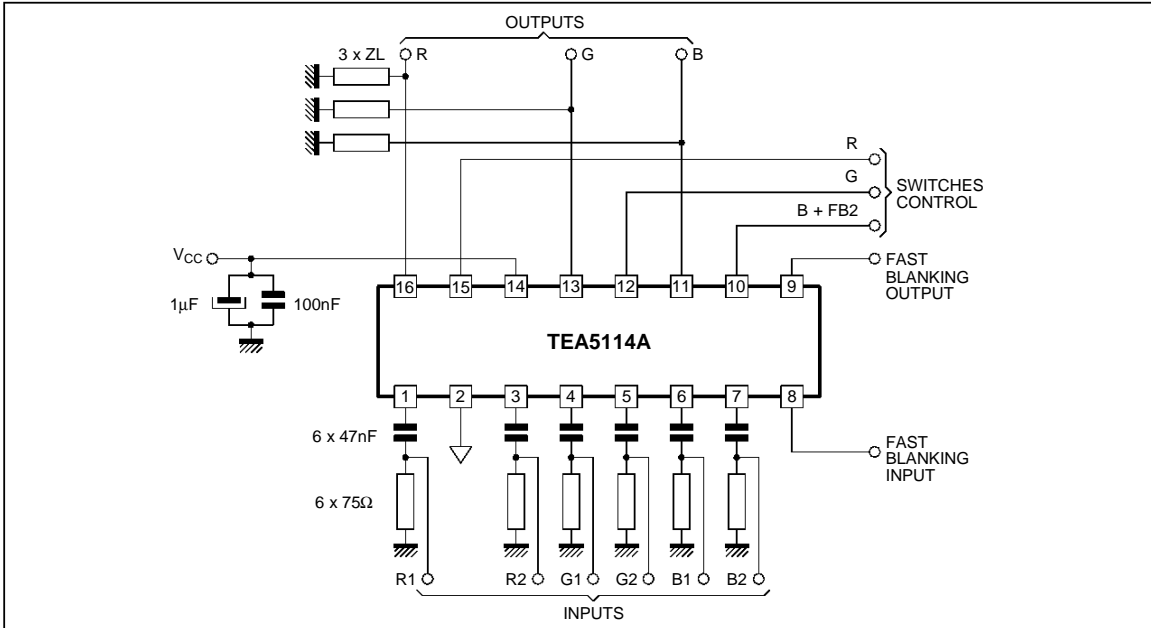

5114A-03.EPS

TYPICAL R, G, B SWITCHING APPLICATION

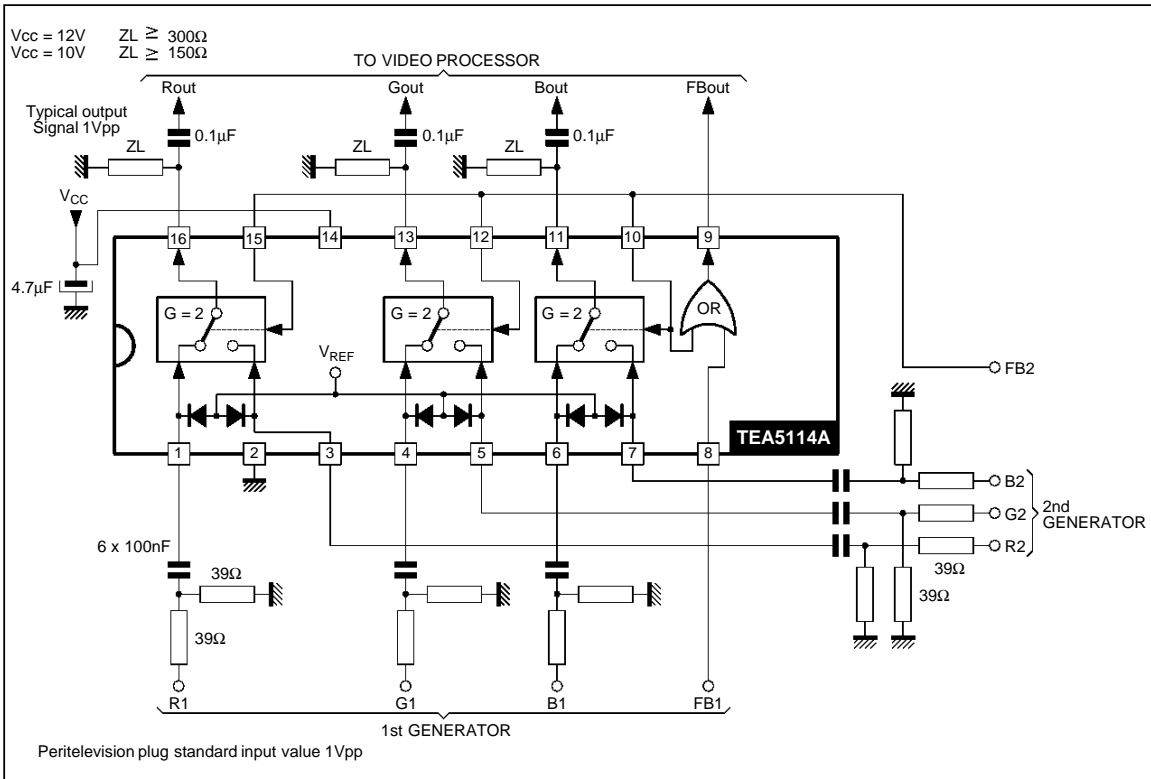

5114A-04.EPS

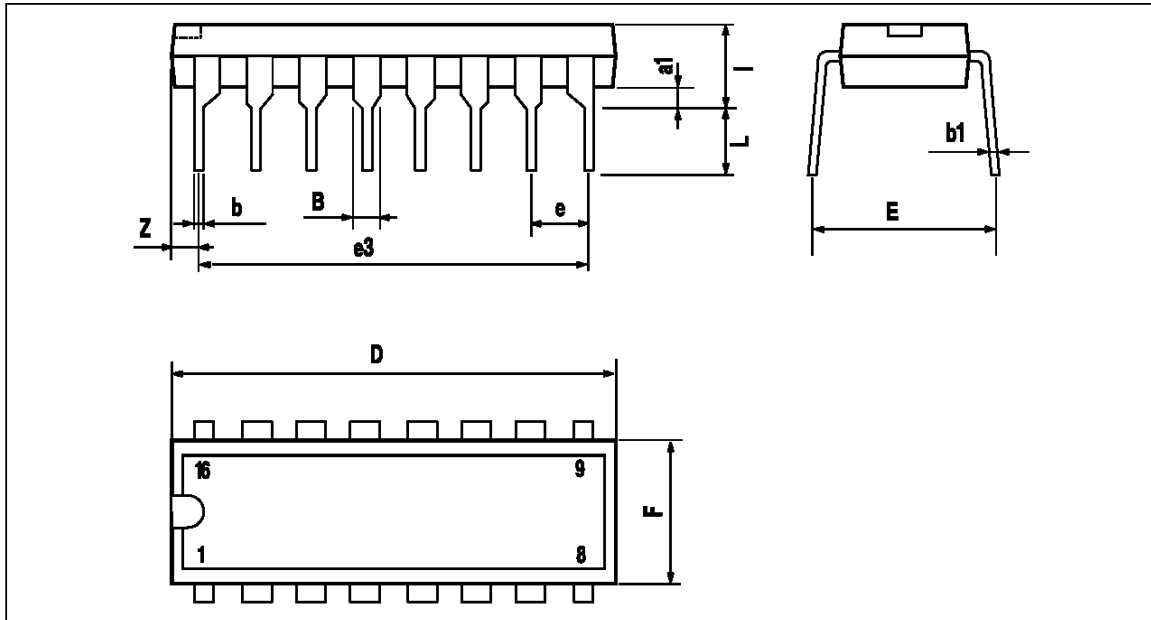
PACKAGE MECHANICAL DATA
 16 PINS – PLASTIC DIP

PM-DIP16.EPS

Dimensions	Millimeters			Inches		
	Min.	Typ.	Max.	Min.	Typ.	Max.
a1	0.51			0.020		
B	0.77		1.65	0.030		0.065
b		0.5			0.020	
b1		0.25			0.010	
D			20			0.787
E		8.5			0.335	
e		2.54			0.100	
e3		17.78			0.700	
F			7.1			0.280
l			5.1			0.201
L		3.3			0.130	
Z			1.27			0.050

DIP16.TBL

Information furnished is believed to be accurate and reliable. However, SGS-THOMSON Microelectronics assumes no responsibility for the consequences of use of such information nor for any infringement of patents or other rights of third parties which may result from its use. No licence is granted by implication or otherwise under any patent or patent rights of SGS-THOMSON Microelectronics. Specifications mentioned in this publication are subject to change without notice. This publication supersedes and replaces all information previously supplied. SGS-THOMSON Microelectronics products are not authorized for use as critical components in life support devices or systems without express written approval of SGS-THOMSON Microelectronics.

© 1996 SGS-THOMSON Microelectronics - All Rights Reserved

Purchase of μ C Components of SGS-THOMSON Microelectronics, conveys a license under the Philips μ C Patent. Rights to use these components in a μ C system, is granted provided that the system conforms to the μ C Standard Specifications as defined by Philips.

SGS-THOMSON Microelectronics GROUP OF COMPANIES

Australia - Brazil - Canada - China - France - Germany - Hong Kong - Italy - Japan - Korea - Malaysia - Malta - Morocco
 The Netherlands - Singapore - Spain - Sweden - Switzerland - Taiwan - Thailand - United Kingdom - U.S.A.