

**FM IF SYSTEM FOR CAR RADIOS**

The KA2244 is a monolithic integrated circuit consisting of FM IF amplifier, detector, muting circuit and signal meter driver. It is suitable for car radios.

**FUNCTIONS**

- 3-stage IF amplifiers.
- Peak detector.
- Muting circuit.
- Signal meter drive circuit.

**FEATURES**

- Suitable for FM car radios.
- Wide operating supply voltage range:  $V_{CC} = 8V \sim 15V$
- High detector output voltage ( $V_O = 500mV$ , Typ).
- Variable muting level.
- Muting off by Pin 4 open.
- Simplified single coil tuning.
- Low distortion (THD=0.1%; Typ).
- Minimum number of external parts required.

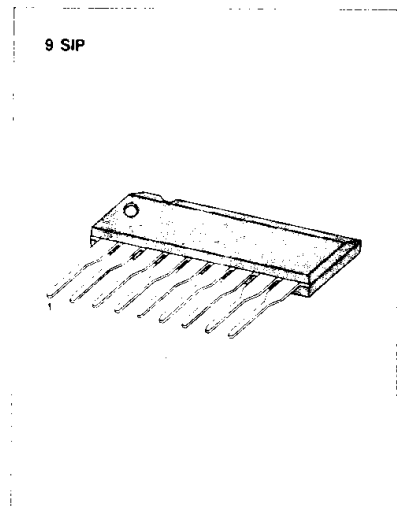

**ORDERING INFORMATION**

Device	Package	Operating Temperature
KA2244	9 SIP	-20°C ~ +70°C

**BLOCK DIAGRAM**

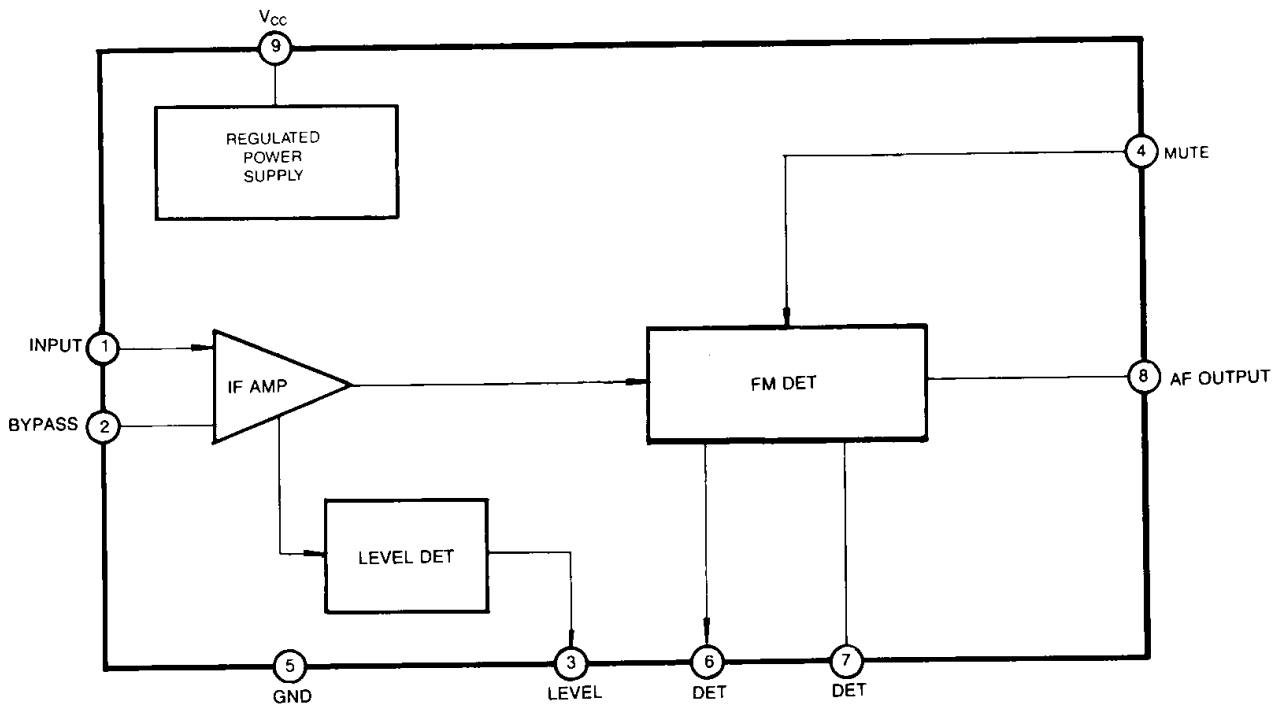

Fig. 1

ABSOLUTE MAXIMUM RATINGS ( $T_a = 25^\circ\text{C}$ )

Characteristic	Symbol	Value	Unit
Supply Voltage	$V_{CC}$	16	V
Input Voltage	$V_I$	0.7	V
Power Dissipation	$P_D$	750	mW
Operating Temperature	$T_{OPR}$	-20 ~ +70	$^\circ\text{C}$
Storage Temperature	$T_{STG}$	-40 ~ +125	$^\circ\text{C}$

\*: Derated above  $T_a = 25^\circ\text{C}$  in the proportion of  $4\text{mW}/^\circ\text{C}$

## ELECTRICAL CHARACTERISTICS

( $T_a = 25^\circ\text{C}$ ,  $V_{CC} = 12\text{V}$ ,  $f = 10.7\text{MHz}$ ,  $f_m = 400\text{Hz}$ , unless otherwise specified)

Characteristic	Symbol	Test Conditions	Min	Typ	Max	Unit
Quiescent Circuit Current	$I_{CCQ}$	$V_I = 0$	10	14	18	mA
-3dB Limiting Sensitivity	$V_{I(LIM)}$	-3dB point from $V_O$ ( $V_I = 80\text{dB}\mu$ , $\Delta f = \pm 75\text{KHz}$ )		50	55	$\text{dB}\mu$
AM Rejection Ratio	AMR	FM: $\Delta f = \pm 75\text{KHz}$ dev AM: 30% Mod, $f_m = 1\text{KHz}$ $V_I = 80\text{dB}\mu$		50		dB
Detector Output Voltage	$V_{O(DET)}$	$\Delta f = \pm 75\text{KHz}$ dev $V_I = 80\text{dB}\mu$	300	500	700	mV
Total Harmonic Distortion	THD	$\Delta f = \pm 22.5\text{KHz}$ dev $V_I = 80\text{dB}\mu$		0.1		%
Signal to Noise Ratio	S/N	$\Delta f = \pm 75\text{KHz}$ dev $V_I = 80\text{dB}\mu$		75		dB
Muting Attenuation	$ATT_{MUTE}$	$\Delta f = \pm 75\text{KHz}$ dev $V_I = 80\text{dB}\mu$ , $V_A = 0$		70		dB
Meter Driver Voltage	$V_M$	$V_I = 110\text{dB}\mu$		4.0		V

TEST CIRCUIT

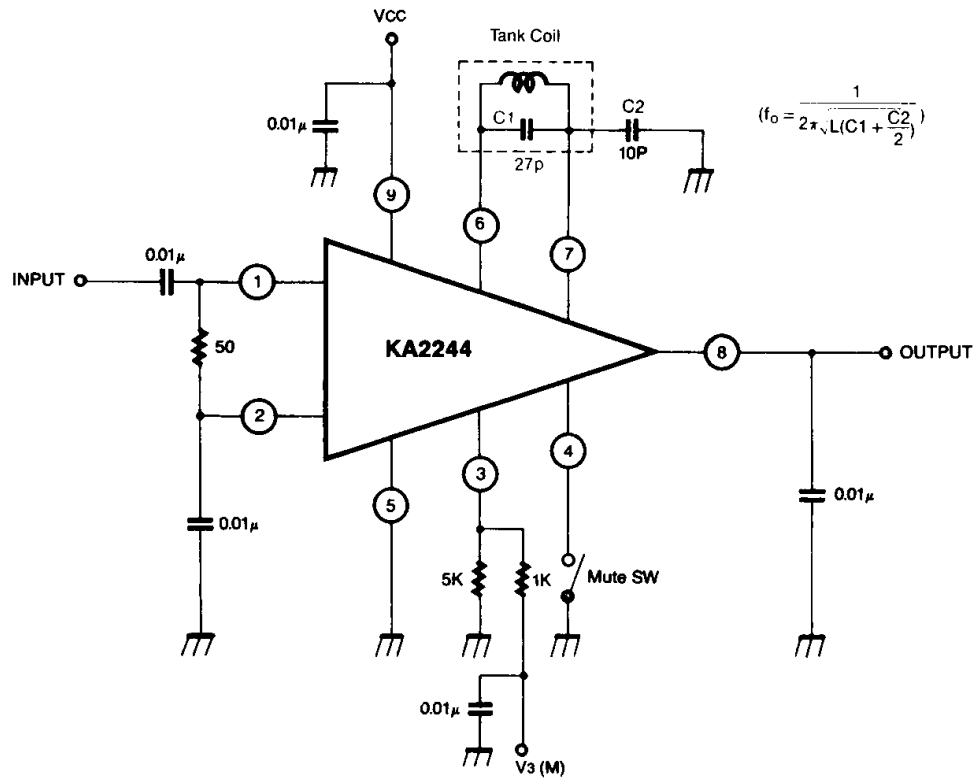
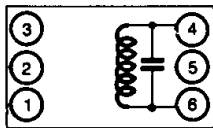

Fig. 2

COIL SPECIFICATIONS



C <sub>o</sub> (pF)	f (MHz)	Q <sub>o</sub> (%)	TURNS		
			4-6		
27	10.7	150	18		

Seoul Jupa SJ-59JG-045 0.1mmφ UEW

