

Features

- Adjustable constant output current
- Wide input voltage range
- Low drop voltage
- Open load detection
- Overtemperature protection
- Short circuit proof
- Reverse polarity proof
- Wide temperature range: $-40\text{ °C} < T_j < 150\text{ °C}$
- Very small SMD-Package

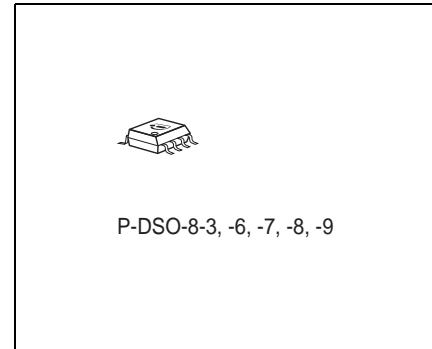

Functional Description

The **TLE 4241 GM** is an integrated adjustable constant current source. It provides an output current adjustable via different means (SET, PWM, reference resistor) which is kept nearly independent from load and supply voltage changes. The IC is designed to supply LEDs under the severe conditions of automotive applications resulting in constant brightness and extended LED lifetime. It is provided in the very small P-DSO-8-9 (Micro 8) package. Protection circuits prevent damage to the device in case of overload, short circuit, reverse polarity and overtemperature. The connected LEDs are protected against reverse polarity as well as excess voltages up to 45 V. A status output allows handling of open load and short circuit at the main output.

A PWM input offers the possibility to adjust the LED brightness by pulse width modulation.

With an implemented high/low current switch the output current level can be reduced e.g. for brake/tail light application.

The implemented features such as adjustable output current, the high/low current switch and the provided PWM input make the device well suited for a broad range of LED and other applications.

Type	Ordering Code	Package
TLE 4241 GM	Q67006-A9644	P-DSO-8-9

Circuit Description

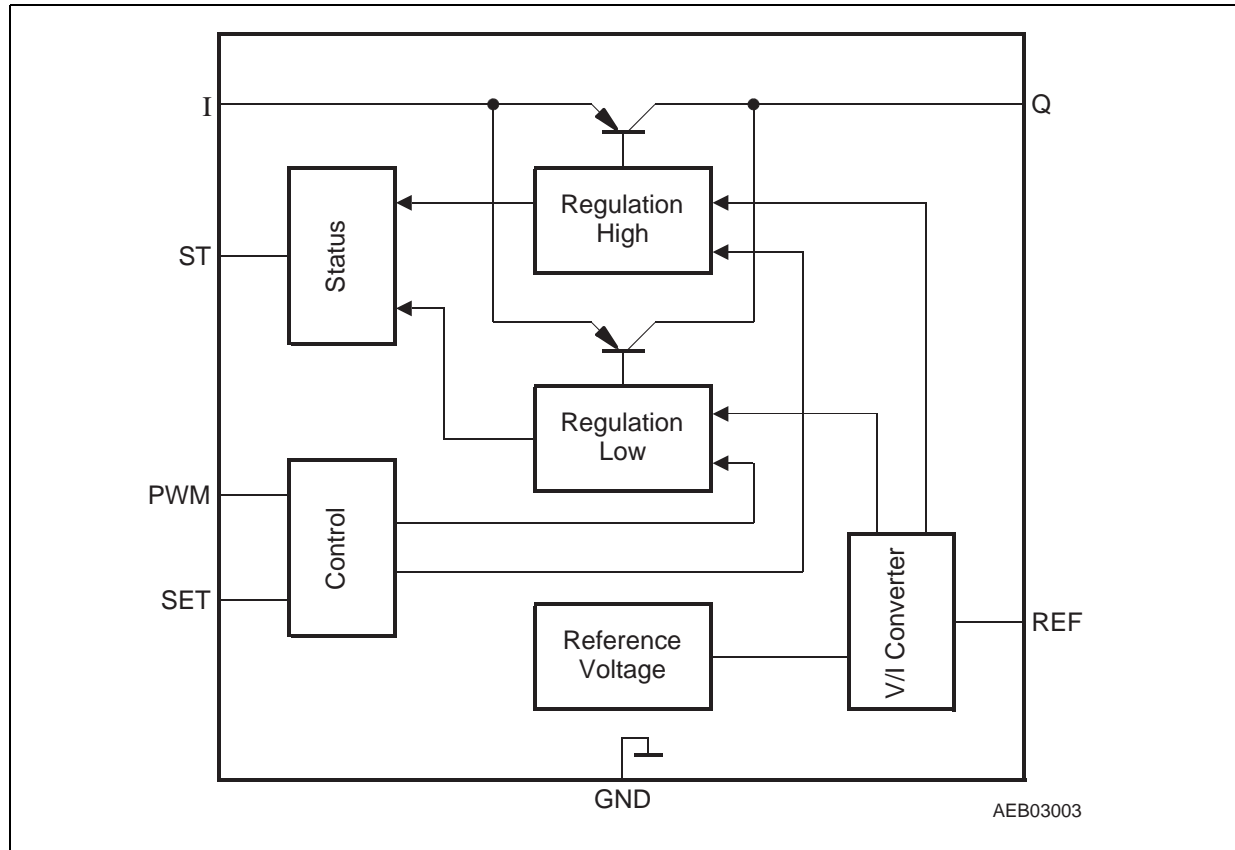

Figure 1 Block Diagram

An internal reference voltage of typ. 1.20 V supplies the REF pin which is connected to GND via an external resistor. In the SET = H mode the reference current flowing on the REF pin is mirrored with an amplification to form the desired output current. The typ. output current in the SET = H mode calculates:

$$I_{Q, \text{typ}}/\text{mA} = \frac{1.20}{R_{\text{REF}}/\text{k}\Omega} \times 487 + 0.1 \tag{1}$$

The output current is shown as a function of the reference resistance on [Page 10](#) for the high as well as for the low current mode.

With the PWM input the LED brightness can be regulated via duty cycle. Also PWM = L sets the TLE 4241 in sleep mode resulting in a very low current consumption of $\ll 1 \mu\text{A}$ typ. Due to the high impedance of the PWM input (see timing diagram I_{PWM} versus V_{PWM} on [Page 12](#)) the PWM pin can thus also be used as an Enable input.

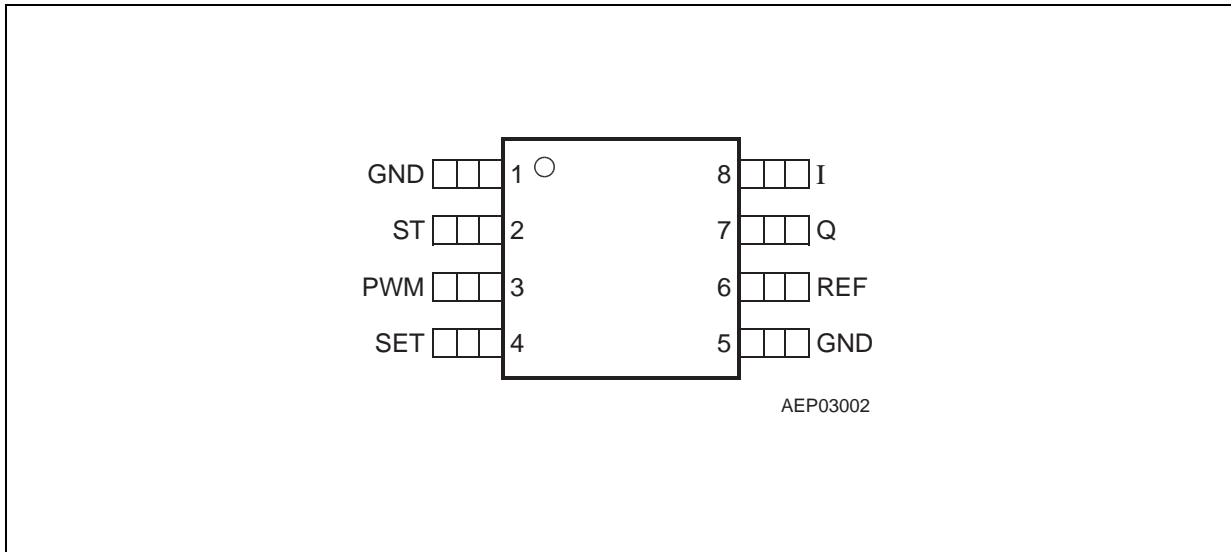

Figure 2 Pin Configuration (top view)

Table 1 Pin Definitions and Functions

Pin No.	Symbol	Function
1	GND	Ground ; internally connected to pin 5
2	ST	Status Output ; open collector output, connect to external pull-up resistor (10 kΩ or higher)
3	PWM	Pulse Width Modulation Input ; if not needed connect to V_I
4	SET	High/Low Current Input ; choice of current level
5	GND	Ground ; internally connected to pin 1
6	REF	Reference Input ; connect to GND via an external resistor to adjust the output current
7	Q	Output
8	I	Input ; block to GND directly at the IC with a 100 nF ceramic capacitor

Application Information

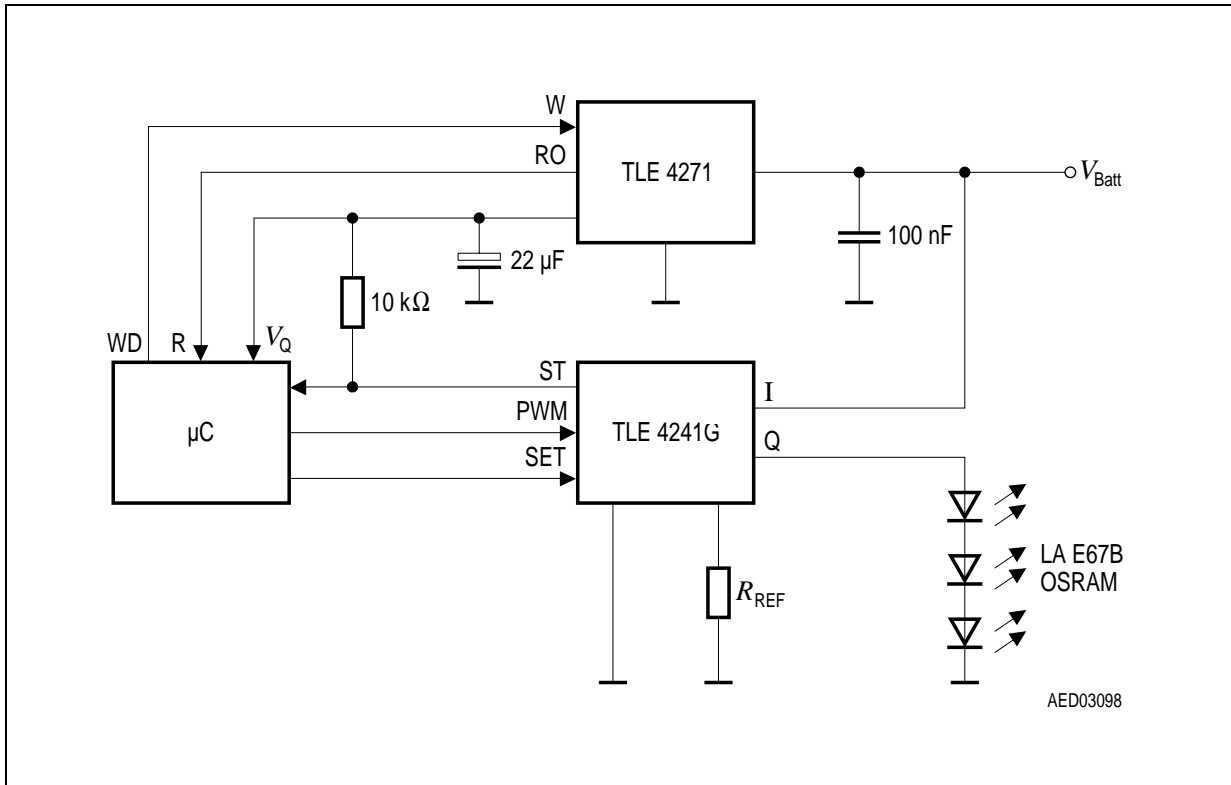

Figure 3 Application Circuit

Figure 3 shows a typical application with the TLE 4241 GM LED driver. The 3 LEDs are driven with an adequate supply current adjusted by the resistor R_{REF} . Thus brightness variations due to forward voltage spread of the LEDs are prevented. The luminosity spread arising from the LED production process can be compensated via software by an appropriate duty cycle applied to the PWM pin. Hence selection of the LEDs to forward voltage as well as to luminosity classes can be spared. The slightly negative temperature coefficient of the TLE 4241 GM output current protects the LEDs against over-temperature stress if the IC is placed nearby the LEDs.

The voltage drop ($V_I - V_Q$) across the TLE 4241 GM is monitored in order to detect an open load condition indicated at the status output pin ST. In case of open load, the voltage drop will decrease below the lower status switching threshold $V_{dr,L}$. Hence, the status output ST will be driven low. In normal operation, the voltage drop is above the upper status threshold $V_{dr,H}$, thus the open collector output ST is in high-ohmic state (see also section Status Output at the Electrical Characteristics).

The function of ST, SET and PWM as well as their timings are shown in **Figure 4**.

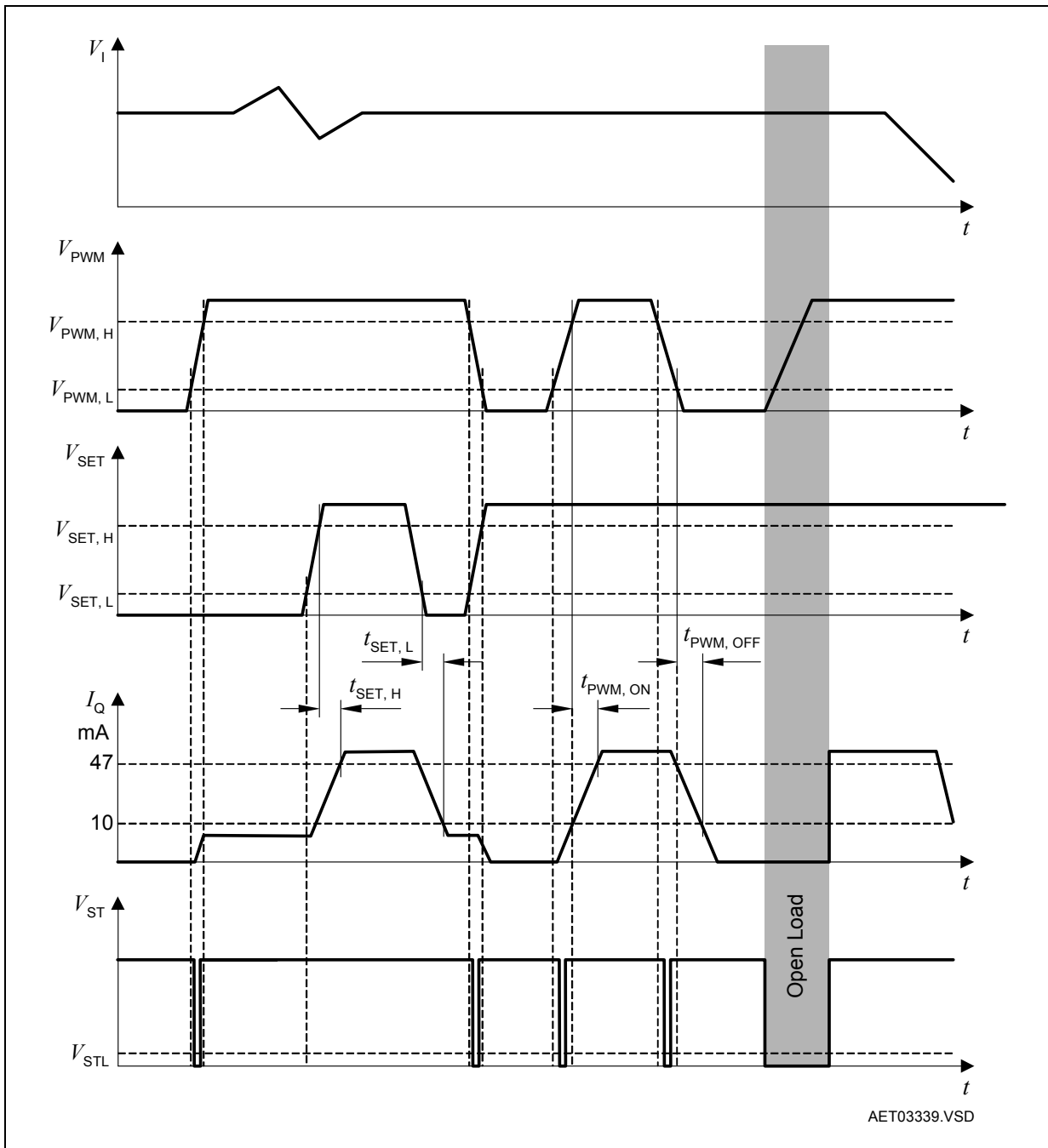

Figure 4 Function and Timing Diagram

Table 2 Absolute Maximum Ratings
 $-40\text{ °C} < T_j < 150\text{ °C}$

Parameter	Symbol	Limit Values		Unit	Remarks
		Min.	Max.		
Input					
Voltage	V_I	-42	45	V	–
Current	I_I	–	–	mA	internally limited
Output					
Voltage	V_Q	-1	40	V	–
Current	I_Q	–	–	mA	internally limited
Status Output					
Voltage	V_{ST}	-0.3	40	V	–
Current	I_{ST}	– 5	5	mA	internally limited
Reference Input					
Voltage	V_{REF}	-0.3	7	V	–
Current	I_{REF}	-2	2	mA	–
Pulse Width Modulation Input					
Voltage	V_{PWM}	-40	40	V	–
Current	–	-1	1	mA	–
High/Low Current Input					
Voltage	V_{SET}	-40	40	V	–
Current	I_{SET}	-1	1	mA	–
Temperatures					
Junction temperature	T_j	-40	150	°C	–
Storage temperature	T_{stg}	-50	150	°C	–
Thermal Resistances					
Junction ambient	R_{thja}	–	105	K/W	1)

1) Worst case regarding peak temperature; mounted on PCB $80 \times 80 \times 1.5\text{ mm}^3$, $35\text{ }\mu\text{m Cu}$, 300 mm^2 heat sink area.

Note: Maximum ratings are absolute ratings; exceeding any one of these values may cause irreversible damage to the integrated circuit.

Table 3 Operating Range

Parameter	Symbol	Limit Values		Unit	Remarks
		Min.	Max.		
Input voltage	V_I	4	45	V	–
Status output voltage	V_{ST}	–	16	V	–
SET voltage	V_{SET}	0	40	V	–
PWM voltage	V_{PWM}	0	40	V	–
Junction temperature	T_j	-40	150	°C	–
Reference Resistor	R_{REF}	7	100	k Ω	SET = H
		4.7	18	k Ω	SET = L

Table 4 Electrical Characteristics

9 V ≤ V_I ≤ 16 V; R_{REF} = 10 kΩ; V_{PWM} ≥ V_{PWM,H}; -40 °C < T_j < 150 °C; all voltages with respect to ground; positive current defined flowing into pin; unless otherwise specified

Parameter	Symbol	Limit Values			Unit	Test Condition
		Min.	Typ.	Max.		
Current consumption off mode	I _{qOFF}	–	0.1	2	μA	PWM = L, T _j < 85 °C; V _I ≤ 13.5 V
Current consumption	I _{qL}	–	5	10	mA	SET = L; V _Q = 6 V
Current consumption	I _{qH}	–	6	10	mA	SET = H; V _Q = 6 V
Current consumption open load	I _{qL,O}	–	–	10	mA	SET = L; V _Q open
Current consumption open load	I _{qH,O}	–	–	10	mA	SET = H; V _Q open

Output

Output current	I _Q	6.7	8.4	10	mA	SET = L, V _Q = 6 V
		–	8.6	–	mA	SET = L, V _Q = 4 V
Output current	I _Q	47	58.5	70	mA	SET = H, V _Q = 6 V
		–	60.0	–	mA	SET = H, V _Q = 4 V
Current Ratio	I _{qH} /I _{qL}	6	7	8	–	–
Output current limit	I _{Qmax}	–	83	–	mA	SET = L; R _{REF} = 0 Ω
Output current limit	I _{Qmax}	–	83	–	mA	SET = H; R _{REF} = 0 Ω
Drop voltage	V _{dr}	–	0.2	0.5	V	SET = L; I _Q = 80% of I _{Q,nom,L}
Drop voltage	V _{dr}	–	0.3	0.5	V	SET = H; I _Q = 80% of I _{Q,nom,H}

PWM Input

PWM high level	V _{PWM,H}	2.0	–	–	V	–
PWM low level	V _{PWM,L}	–	–	0.5	V	–
PWM input current high level	I _{PWM,H}	–	220	500	μA	V _{PWM} = 5.0 V
PWM input current low level	I _{PWM,L}	-10	–	10	μA	V _{PWM} = 0.0 V
Turn on delay time	t _{PWM,ON}	0	5	30	μs	20%/80% I _Q , see Figure 4

Table 4 Electrical Characteristics (cont'd)

$9\text{ V} \leq V_1 \leq 16\text{ V}$; $R_{\text{REF}} = 10\text{ k}\Omega$; $V_{\text{PWM}} \geq V_{\text{PWM,H}}$; $-40\text{ }^\circ\text{C} < T_j < 150\text{ }^\circ\text{C}$; all voltages with respect to ground; positive current defined flowing into pin; unless otherwise specified

Parameter	Symbol	Limit Values			Unit	Test Condition
		Min.	Typ.	Max.		
Turn off delay time	$t_{\text{PWM,OFF}}$	0	10	30	μs	20%/80% I_Q , see Figure 4
SET Input						
SET high level	$V_{\text{SET,H}}$	2.0	–	–	V	–
SET low level	$V_{\text{SET,L}}$	–	–	0.5	V	–
SET input current high level	$I_{\text{SET,H}}$	–	220	500	μA	$V_{\text{SET}} = 5.0\text{ V}$
SET input current low level	$I_{\text{SET,L}}$	-10	–	10	μA	$V_{\text{SET}} = 0.0\text{ V}$
Delay time L -> H	$t_{\text{SET,H}}$	–	–	30	μs	20%/80% I_Q , see Figure 4
Delay time H -> L	$t_{\text{SET,L}}$	–	–	30	μs	20%/80% I_Q , see Figure 4
Status Output						
Lower status switching threshold	$V_{\text{dr,L}}$	0.15	–	–	V	$(V_1 - V_Q)$ decreasing SET = L
		0.15	–	–	V	$(V_1 - V_Q)$ decreasing SET = H
Upper status switching threshold	$V_{\text{dr,H}}$	–	–	0.7	V	$(V_1 - V_Q)$ increasing SET = L
		–	–	0.7	V	$(V_1 - V_Q)$ increasing SET = H
Status low voltage	V_{STL}	–	–	0.4	V	$(V_1 - V_Q) < V_{\text{dr,L}}$ $I_{\text{ST}} = 1.0\text{ mA}$
Leakage current	I_{STLK}	–	–	10	μA	$(V_1 - V_Q) > V_{\text{dr,H}}$ $V_{\text{ST}} = 5.0\text{ V}$

Typical Performance Characteristics

Output Current versus External Resistor, SET = H

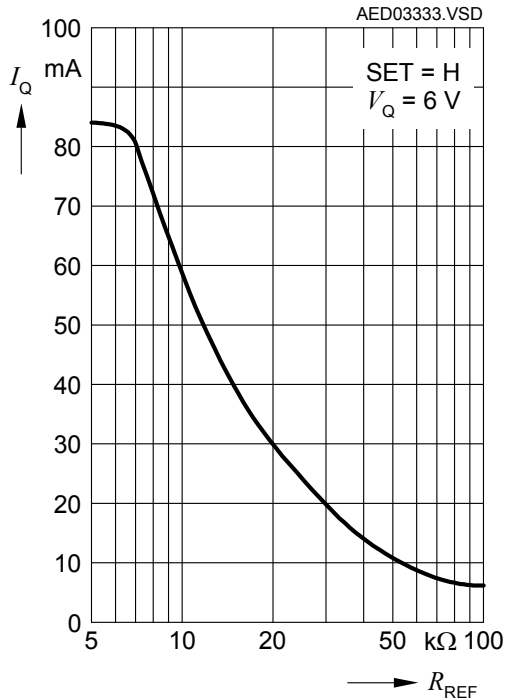

Output Current versus External Resistor, SET = L

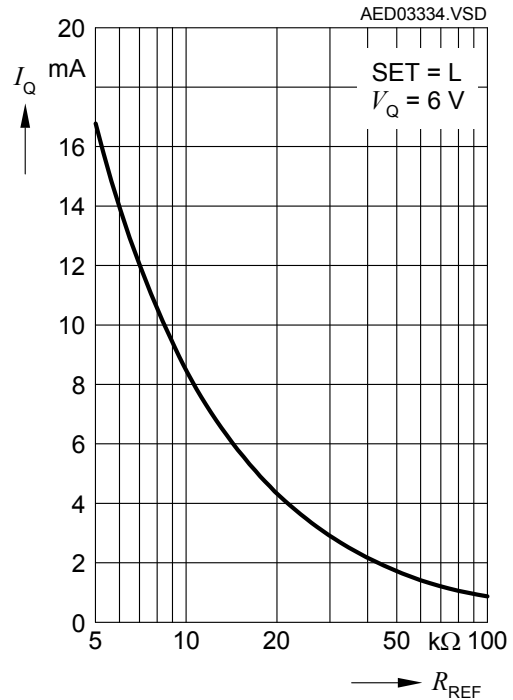

Output Current versus Supply Voltage, SET = H

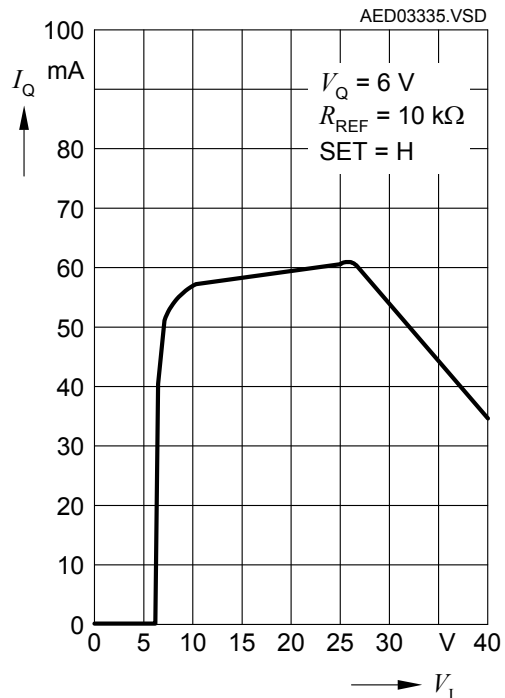

Output Current versus Supply Voltage, SET = L

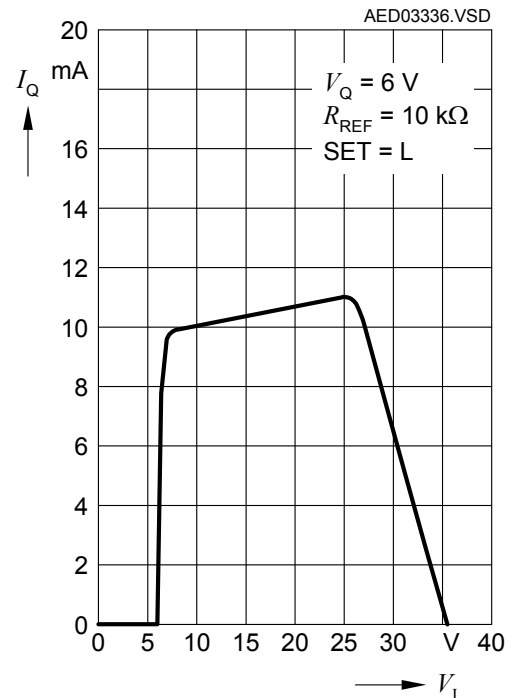

Reference Voltage versus Junction Temperature

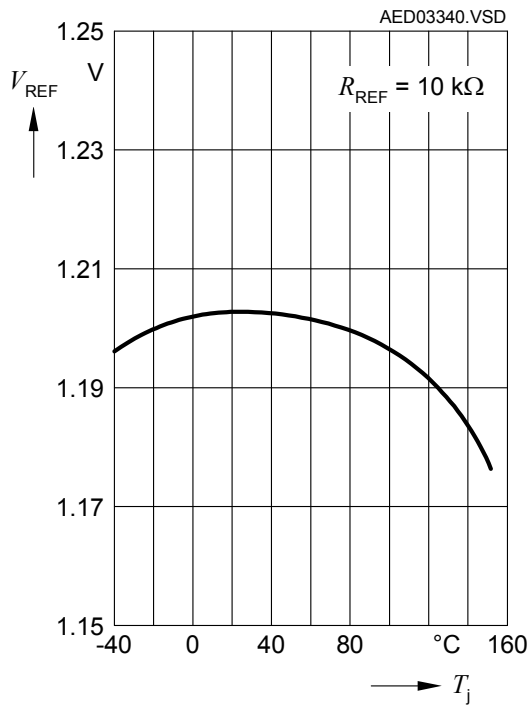

PWM Pin Input Current versus PWM Voltage

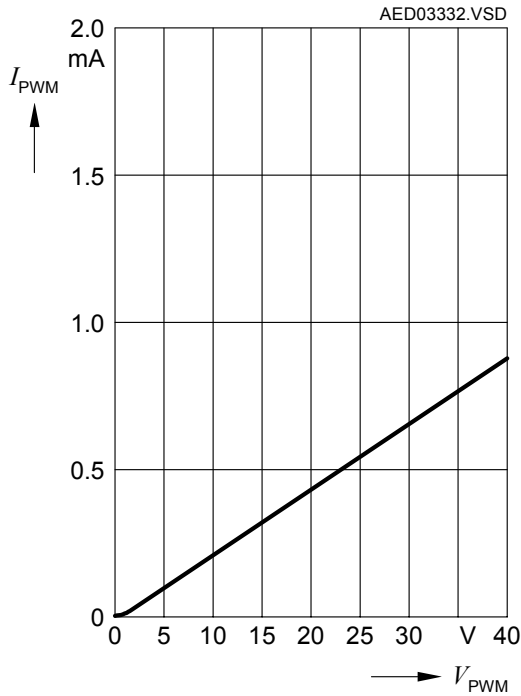

PWM Pin Input Current versus PWM Voltage

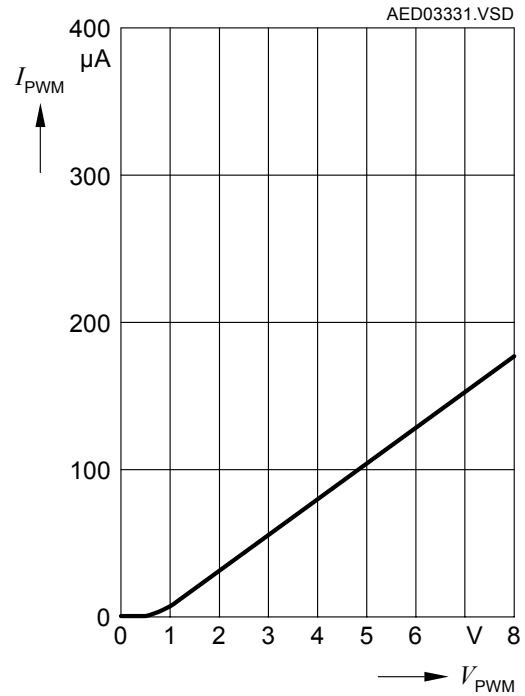

SET Pin Input Current versus SET Voltage

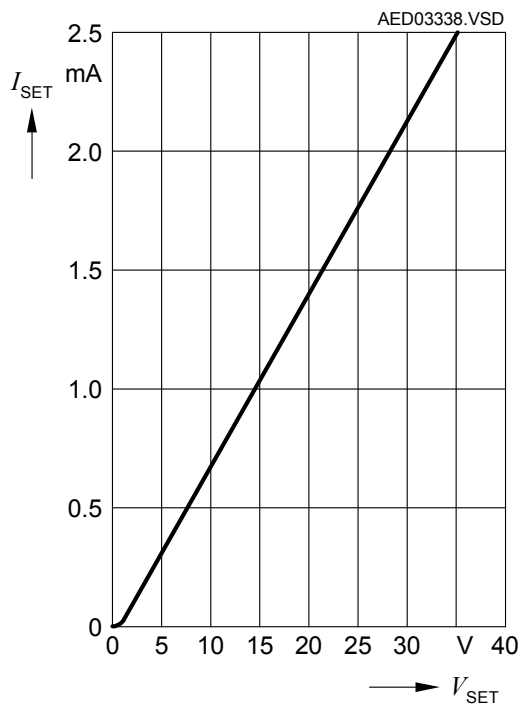

SET Pin Input Current versus SET Voltage

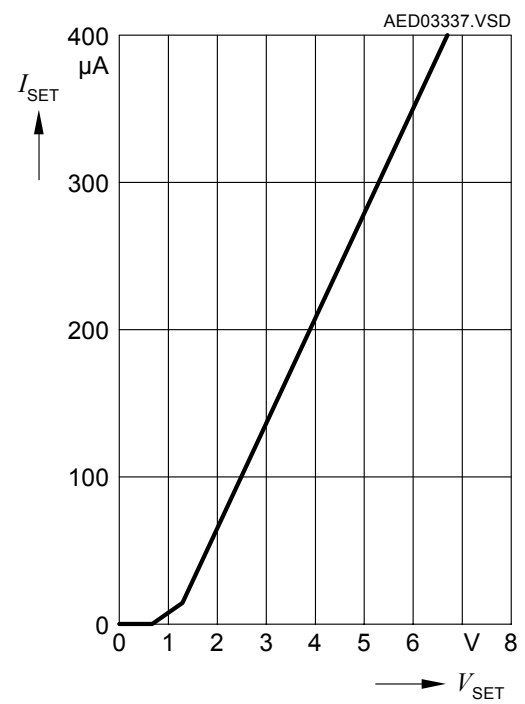

Package Outlines

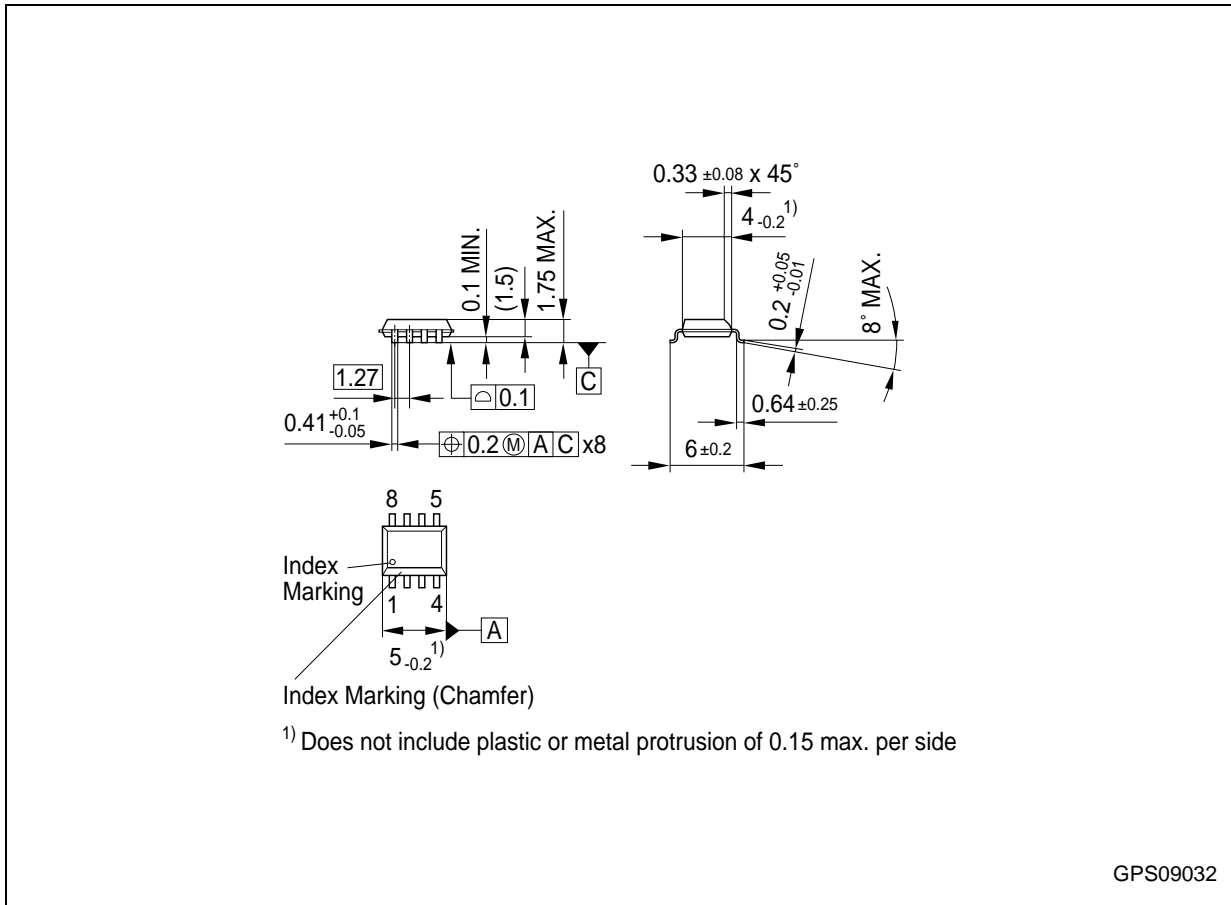

Figure 5 P-DSO-8-9 (Plastic Dual Small Outline)

You can find all of our packages, sorts of packing and others in our Infineon Internet Page "Products": <http://www.infineon.com/products>.

SMD = Surface Mounted Device

Dimensions in mm

Revision History

Version	Date	Changes
Rev. 1.2	2004-04-13	Page 4, 9: Improved indication and explanation of the open load detection function.

Edition 2004-04-13

**Published by Infineon Technologies AG,
St.-Martin-Strasse 53,
81669 München, Germany**

**© Infineon Technologies AG 2004.
All Rights Reserved.**

Attention please!

The information herein is given to describe certain components and shall not be considered as a guarantee of characteristics.

Terms of delivery and rights to technical change reserved.

We hereby disclaim any and all warranties, including but not limited to warranties of non-infringement, regarding circuits, descriptions and charts stated herein.

Information

For further information on technology, delivery terms and conditions and prices please contact your nearest Infineon Technologies Office (www.infineon.com).

Warnings

Due to technical requirements components may contain dangerous substances. For information on the types in question please contact your nearest Infineon Technologies Office.

Infineon Technologies Components may only be used in life-support devices or systems with the express written approval of Infineon Technologies, if a failure of such components can reasonably be expected to cause the failure of that life-support device or system, or to affect the safety or effectiveness of that device or system. Life support devices or systems are intended to be implanted in the human body, or to support and/or maintain and sustain and/or protect human life. If they fail, it is reasonable to assume that the health of the user or other persons may be endangered.