

Freescale Semiconductor, Inc.

MC68HC908AS60/D
REV 1



MC68HC908AS60
Technical Data

HCMOS
Microcontroller Unit



Motorola reserves the right to make changes without further notice to any products herein. Motorola makes no warranty, representation or guarantee regarding the suitability of its products for any particular purpose, nor does Motorola assume any liability arising out of the application or use of any product or circuit, and specifically disclaims any and all liability, including without limitation consequential or incidental damages. "Typical" parameters which may be provided in Motorola data sheets and/or specifications can and do vary in different applications and actual performance may vary over time. All operating parameters, including "Typicals" must be validated for each customer application by customer's technical experts. Motorola does not convey any license under its patent rights nor the rights of others. Motorola products are not designed, intended, or authorized for use as components in systems intended for surgical implant into the body, or other applications intended to support or sustain life, or for any other application in which the failure of the Motorola product could create a situation where personal injury or death may occur. Should Buyer purchase or use Motorola products for any such unintended or unauthorized application, Buyer shall indemnify and hold Motorola and its officers, employees, subsidiaries, affiliates, and distributors harmless against all claims, costs, damages, and expenses, and reasonable attorney fees arising out of, directly or indirectly, any claim of personal injury or death associated with such unintended or unauthorized use, even if such claim alleges that Motorola was negligent regarding the design or manufacture of the part. Motorola, Inc. is an Equal Opportunity/Affirmative Action Employer.

List of Sections

Section 1. General Description33

Section 2. Memory Map47

Section 3. Random-Access Memory (RAM)61

Section 4. FLASH-1 Memory63

Section 5. FLASH-2 Memory77

Section 6. EEPROM-189

Section 7. EEPROM-2101

Section 8. Central Processor Unit (CPU)113

Section 9. System Integration Module (SIM)133

Section 10. Clock Generator Module (CGM)155

Section 11. Configuration Register (CONFIG-1)181

Section 12. Break Module185

Section 13. Monitor ROM (MON)191

**Section 14. Computer Operating Properly
(COP) Module203**

Section 15. Low-Voltage Inhibit (LVI) Module209

Section 16. External Interrupt Module (IRQ)215

**Section 17. Serial Communications
Interface (SCI)223**

Section 18. Serial Peripheral Interface (SPI)259

Section 19. Modulo Timer (TIM)291

Section 20. Input/Output (I/O) Ports301

**Section 21. Byte Data Link
Controller-Digital (BDLC-D)327**

Section 22. Timer Interface Module A (TIMA-6)375

Section 23. Analog-to-Digital Converter (ADC-15)407

Section 24. Electrical Specifications419

Section 25. Mechanical Specifications433

Section 26. Ordering Information437

Index439

Table of Contents

Section 1. General Description

1.1 Contents 33

1.2 Introduction 34

1.3 Features 34

1.4 MCU Block Diagram 35

1.5 Pin Assignments 37

1.5.1 Power Supply Pins (V_{DD} and V_{SS}) 39

1.5.2 Oscillator Pins (OSC1 and OSC2) 40

1.5.3 External Reset Pin (\overline{RST}) 40

1.5.4 External Interrupt Pin (\overline{IRQ}) 40

1.5.5 Analog Power Supply Pin (V_{DDA}) 40

1.5.6 Analog Ground Pin (V_{SSA}) 40

1.5.7 External Filter Capacitor Pin (CGMXFC) 41

1.5.8 Port A Input/Output (I/O) Pins (PTA7–PTA0) 41

1.5.9 Port B I/O Pins (PTB7/ATD7–PTB0/ATD0) 41

1.5.10 Port C I/O Pins (PTC5–PTC0) 41

1.5.11 Port D I/O Pins (PTD7–PTD0/ATD8) 41

1.5.12 Port E I/O Pins (PTE7/SPSCK–PTE0/TxD) 41

1.5.13 Port F I/O Pins (PTF7–PTF0/TACH2) 42

1.5.14 Port G I/O Pins (PTG2–PTG0) 42

1.5.15 Port H I/O Pins (PTH1–PTH0) 42

1.5.16 BDLC Transmit Pin (BDLTD) 42

1.5.17 BDLC Receive Pin (BDRxD) 42

Section 2. Memory Map

2.1 Contents47
 2.2 Introduction47
 2.3 Input/Output Section50

Section 3. Random-Access Memory (RAM)

3.1 Contents61
 3.2 Introduction61
 3.3 Functional Description61

Section 4. FLASH-1 Memory

4.1 Contents63
 4.2 Introduction63
 4.3 Functional Description64
 4.4 FLASH-1 Control Register65
 4.5 FLASH Charge Pump Frequency Control67
 4.6 FLASH Erase Operation67
 4.7 FLASH Program/Margin Read Operation68
 4.8 FLASH Block Protection70
 4.8.1 FLASH-1 Block Protect Register72
 4.8.2 FLASH-2 Block Protect Register73
 4.9 Low-Power Modes75
 4.9.1 Wait Mode75
 4.9.2 Stop Mode75

Section 5. FLASH-2 Memory

5.1 Contents77
 5.2 Introduction77
 5.3 Functional Description78

5.4	FLASH Control Register	79
5.5	FLASH Charge Pump Frequency Control	81
5.6	FLASH Erase Operation	81
5.7	FLASH Program/Margin Read Operation	82
5.8	FLASH Block Protection	84
5.9	FLASH Block Protect Register	86
5.10	Low-Power Modes	86
5.10.1	Wait Mode	86
5.10.2	Stop Mode	86

Section 6. EEPROM-1

6.1	Contents	89
6.2	Introduction	89
6.3	Features	90
6.4	Functional Description	90
6.4.1	EEPROM Programming	90
6.4.2	EEPROM Erasing	92
6.4.3	EEPROM Block Protection	94
6.4.4	EEPROM Redundant Mode	94
6.4.5	MCU Configuration	95
6.4.6	EEPROM Protection	95
6.4.7	EEPROM Control Register	96
6.4.8	EEPROM Non-Volatile Register and EEPROM Array Configuration Register	98
6.5	Low-Power Modes	100
6.5.1	Wait Mode	100
6.5.2	Stop Mode	100

Section 7. EEPROM-2

7.1	Contents	101
7.2	Introduction	101
7.3	Features	102
7.4	Functional Description	102
7.4.1	EEPROM Programming	102
7.4.2	EEPROM Erasing	104
7.4.3	EEPROM Block Protection	106
7.4.4	EEPROM Redundant Mode	106
7.4.5	MCU Configuration	107
7.4.6	MC68HC908AS60 EEPROM Protect	107
7.4.7	EEPROM Control Register	108
7.4.8	EEPROM Non-Volatile Register and EEPROM Array Control Register	110
7.5	Low-Power Modes	112
7.5.1	Wait Mode	112
7.5.2	Stop Mode	112

Section 8. Central Processor Unit (CPU)

8.1	Contents	113
8.2	Introduction	113
8.3	Features	114
8.4	CPU Registers	115
8.4.1	Accumulator (A)	116
8.4.2	Index Register (H:X)	116
8.4.3	Stack Pointer (SP)	117
8.4.4	Program Counter (PC)	118
8.4.5	Condition Code Register (CCR)	119
8.5	Arithmetic/Logic Unit (ALU)	121
8.6	Low-Power Modes	121
8.6.1	Wait Mode	121
8.6.2	Stop Mode	121

8.7 CPU During Break Interrupts 122

8.8 Instruction Set Summary 122

8.9 Opcode Map 130

Section 9. System Integration Module (SIM)

9.1 Contents 133

9.2 Introduction 134

9.3 SIM Bus Clock Control and Generation 137

9.3.1 Bus Timing 137

9.3.2 Clock Startup from POR or LVI Reset 137

9.3.3 Clocks in Stop Mode and Wait Mode 138

9.4 Reset and System Initialization 138

9.4.1 External Pin Reset 139

9.4.2 Active Resets from Internal Sources 139

9.4.2.1 Power-On Reset (POR) 140

9.4.2.2 Computer Operating Properly (COP) Reset 141

9.4.2.3 Illegal Opcode Reset 141

9.4.2.4 Illegal Address Reset 141

9.4.2.5 Low-Voltage Inhibit (LVI) Reset 142

9.5 SIM Counter 142

9.5.1 SIM Counter During Power-On Reset 142

9.5.2 SIM Counter During Stop Mode Recovery 143

9.5.3 SIM Counter and Reset States 143

9.6 Program Exception Control 143

9.6.1 Interrupts 143

9.6.1.1 Hardware Interrupts 146

9.6.1.2 SWI Instruction 146

9.6.2 Reset 147

9.6.3 Break Interrupts 147

9.6.4 Status Flag Protection in Break Mode 147

9.7 Low-Power Modes 148

9.7.1 Wait Mode 148

9.7.2 Stop Mode 149

9.8 SIM Registers 151
 9.8.1 SIM Break Status Register 151
 9.8.2 SIM Reset Status Register 153
 9.8.3 SIM Break Flag Control Register 154

Section 10. Clock Generator Module (CGM)

10.1 Contents 155
 10.2 Introduction 156
 10.3 Features 156
 10.4 Functional Description 157
 10.4.1 Crystal Oscillator Circuit 157
 10.4.2 Phase-Locked Loop Circuit (PLL) 159
 10.4.2.1 Circuits 159
 10.4.2.2 Acquisition and Tracking Modes 161
 10.4.2.3 Manual and Automatic PLL Bandwidth Modes 161
 10.4.2.4 Programming the PLL 163
 10.4.2.5 Special Programming Exceptions 165
 10.4.3 Base Clock Selector Circuit 165
 10.4.4 CGM External Connections 166
 10.5 I/O Signals 167
 10.5.1 Crystal Amplifier Input Pin (OSC1) 167
 10.5.2 Crystal Amplifier Output Pin (OSC2) 167
 10.5.3 External Filter Capacitor Pin (CGMXFC) 167
 10.5.4 Analog Power Pin (V_{DDA}) 168
 10.5.5 Oscillator Enable Signal (SIMOSCEN) 168
 10.5.6 Crystal Output Frequency Signal (CGMXCLK) 168
 10.5.7 CGM Base Clock Output (CGMOUT) 168
 10.5.8 CGM CPU Interrupt (CGMINT) 168
 10.6 CGM Registers 169
 10.6.1 PLL Control Register 169
 10.6.2 PLL Bandwidth Control Register 171
 10.6.3 PLL Programming Register 173
 10.7 Interrupts 174

10.8 Low-Power Modes175
 10.8.1 Wait Mode175
 10.8.2 Stop Mode175
 10.9 CGM During Break Interrupts175
 10.10 Acquisition/Lock Time Specifications176
 10.10.1 Acquisition/Lock Time Definitions176
 10.10.2 Parametric Influences on Reaction Time177
 10.10.3 Choosing a Filter Capacitor178

Section 11. Configuration Register (CONFIG-1)

11.1 Contents181
 11.2 Introduction181
 11.3 Functional Description181

Section 12. Break Module

12.1 Contents185
 12.2 Introduction185
 12.3 Features185
 12.4 Functional Description186
 12.4.1 Flag Protection During Break Interrupts187
 12.4.2 CPU During Break Interrupts187
 12.4.3 TIM During Break Interrupts187
 12.4.4 COP During Break Interrupts188
 12.5 Low-Power Modes188
 12.5.1 Wait Mode188
 12.5.2 Stop Mode188
 12.6 Break Module Registers188
 12.6.1 Break Status and Control Register189
 12.6.2 Break Address Registers190

Section 13. Monitor ROM (MON)

13.1 Contents 191

13.2 Introduction 191

13.3 Features 192

13.4 Functional Description 192

13.4.1 Entering Monitor Mode 194

13.4.2 Data Format 195

13.4.3 Echoing 196

13.4.4 Break Signal 196

13.4.5 Commands 197

13.4.6 Baud Rate 199

13.4.7 Security 199

Section 14. Computer Operating Properly (COP) Module

14.1 Contents 203

14.2 Introduction 203

14.3 Functional Description 204

14.4 I/O Signals 205

14.4.1 CGMXCLK 205

14.4.2 STOP Instruction 205

14.4.3 COPCTL Write 206

14.4.4 Power-On Reset 206

14.4.5 Internal Reset 206

14.4.6 Reset Vector Fetch 206

14.4.7 COPD 206

14.4.8 COPL 206

14.5 COP Control Register 207

14.6 Interrupts 207

14.7 Monitor Mode 207

14.8 Low-Power Modes207
 14.8.1 Wait Mode207
 14.8.2 Stop Mode208
 14.9 COP Module During Break Interrupts.....208

Section 15. Low-Voltage Inhibit (LVI) Module

15.1 Contents209
 15.2 Introduction.....209
 15.3 Features210
 15.4 Functional Description210
 15.4.1 Polled LVI Operation211
 15.4.2 Forced Reset Operation.....211
 15.4.3 False Reset Protection.....212
 15.5 LVI Status Register.....212
 15.6 LVI Interrupts213
 15.7 Low-Power Modes213
 15.7.1 Wait Mode213
 15.7.2 Stop Mode213

Section 16. External Interrupt Module (IRQ)

16.1 Contents215
 16.2 Introduction.....215
 16.3 Features215
 16.4 Functional Description216
 16.5 $\overline{\text{IRQ}}$ Pin.....219
 16.6 IRQ Module During Break Interrupts220
 16.7 IRQ Status and Control Register220

Section 17. Serial Communications Interface (SCI)

17.1 Contents 223

17.2 Introduction 224

17.3 Features 224

17.4 Pin Name Conventions 225

17.5 Functional Description 226

17.5.1 Data Format 228

17.5.2 Transmitter 228

17.5.2.1 Character Length 228

17.5.2.2 Character Transmission 228

17.5.2.3 Break Characters 230

17.5.2.4 Idle Characters 230

17.5.2.5 Inversion of Transmitted Output 231

17.5.2.6 Transmitter Interrupts 231

17.5.3 Receiver 232

17.5.3.1 Character Length 233

17.5.3.2 Character Reception 233

17.5.3.3 Data Sampling 233

17.5.3.4 Framing Errors 236

17.5.3.5 Baud Rate Tolerance 236

17.5.3.6 Receiver Wakeup 238

17.5.3.7 Receiver Interrupts 239

17.5.3.8 Error Interrupts 239

17.6 Low-Power Modes 240

17.6.1 Wait Mode 240

17.6.2 Stop Mode 240

17.7 SCI During Break Module Interrupts 241

17.8 I/O Signals 241

17.8.1 PTE0/SCTxD (Transmit Data) 241

17.8.2 PTE1/SCRxD (Receive Data) 242

17.9 I/O Registers 242

17.9.1 SCI Control Register 1 242

17.9.2 SCI Control Register 2 245

17.9.3 SCI Control Register 3 248

17.9.4 SCI Status Register 1 250

17.9.5 SCI Status Register 2253
 17.9.6 SCI Data Register254
 17.9.7 SCI Baud Rate Register255

Section 18. Serial Peripheral Interface (SPI)

18.1 Contents259
 18.2 Introduction260
 18.3 Features260
 18.4 Pin Name and Register Name Conventions261
 18.5 Functional Description262
 18.5.1 Master Mode263
 18.5.2 Slave Mode265
 18.6 Transmission Formats266
 18.6.1 Clock Phase and Polarity Controls266
 18.6.2 Transmission Format When CPHA = 0267
 18.6.3 Transmission Format When CPHA = 1268
 18.6.4 Transmission Initiation Latency269
 18.7 Error Conditions269
 18.7.1 Overflow Error271
 18.7.2 Mode Fault Error273
 18.8 Interrupts274
 18.9 Queuing Transmission Data276
 18.10 Resetting the SPI277
 18.11 Low-Power Modes278
 18.11.1 Wait Mode278
 18.11.2 Stop Mode278
 18.12 SPI During Break Interrupts278
 18.13 I/O Signals279
 18.13.1 MISO (Master In/Slave Out)280
 18.13.2 MOSI (Master Out/Slave In)280
 18.13.3 SPCK (Serial Clock)280

18.13.4 \overline{SS} (Slave Select) 281
 18.13.5 V_{SS} (Clock Ground) 282
 18.14 I/O Registers 282
 18.14.1 SPI Control Register 283
 18.14.2 SPI Status and Control Register 285
 18.14.3 SPI Data Register 288

Section 19. Modulo Timer (TIM)

19.1 Contents 291
 19.2 Introduction 291
 19.3 Features 292
 19.4 Functional Description 292
 19.5 TIM Counter Prescaler 294
 19.6 Low-Power Modes 294
 19.6.1 Wait Mode 294
 19.6.2 Stop Mode 294
 19.7 TIM During Break Interrupts 295
 19.8 I/O Registers 295
 19.8.1 TIM Status and Control Register 296
 19.8.2 TIM Counter Registers 298
 19.8.3 TIM Counter Modulo Registers 299

Section 20. Input/Output (I/O) Ports

20.1 Contents 301
 20.2 Introduction 302
 20.3 Port A 304
 20.3.1 Port A Data Register 304
 20.3.2 Data Direction Register A 304
 20.4 Port B 306
 20.4.1 Port B Data Register 306
 20.4.2 Data Direction Register B 307

20.5	Port C	308
20.5.1	Port C Data Register	308
20.5.2	Data Direction Register C	309
20.6	Port D	311
20.6.1	Port D Data Register	311
20.6.2	Data Direction Register D	312
20.7	Port E	314
20.7.1	Port E Data Register	314
20.7.2	Data Direction Register E	316
20.8	Port F	318
20.8.1	Port F Data Register	318
20.8.2	Data Direction Register F	319
20.9	Port G	320
20.9.1	Port G Data Register	320
20.9.2	Data Direction Register G	321
20.10	Port H	323
20.10.1	Port H Data Register	323
20.10.2	Data Direction Register H	324

Section 21. Byte Data Link Controller-Digital (BDLC-D)

21.1	Contents	327
21.2	Introduction	329
21.3	Features	329
21.4	Functional Description	330
21.4.1	BDLC Operating Modes	331
21.4.1.1	Power Off Mode	331
21.4.1.2	Reset Mode	332
21.4.1.3	Run Mode	333
21.4.1.4	Wait Mode	333
21.4.1.5	Stop Mode	333
21.4.1.6	Digital Loopback Mode	334
21.4.1.7	Analog Loopback Mode	334

21.5	BDLC MUX Interface	335
21.5.1	Rx Digital Filter	335
21.5.1.1	Operation	336
21.5.1.2	Performance	336
21.5.2	J1850 Frame Format	337
21.5.2.1	Start-of-Frame Symbol (SOF)	337
21.5.2.2	In-Message Data Bytes (Data)	338
21.5.2.3	Cyclical Redundancy Check Byte (CRC)	338
21.5.2.4	End-of-Data Symbol (EOD)	339
21.5.2.5	In-Frame Response Bytes (IFR)	339
21.5.2.6	End-of-Frame Symbol (EOF)	340
21.5.2.7	Inter-Frame Separation Symbol (IFS)	340
21.5.2.8	Break (BREAK)	341
21.5.2.9	Idle Bus (IDLE)	341
21.5.3	J1850 VPW Symbols	341
21.5.3.1	Logic 0	342
21.5.3.2	Logic 1	342
21.5.3.3	Normalization Bit (NB)	344
21.5.3.4	Break Signal (BREAK)	344
21.5.3.5	Start-of-Frame Symbol (SOF)	344
21.5.3.6	End-of-Data Symbol (EOD)	344
21.5.3.7	End-of-Frame Symbol (EOF)	344
21.5.3.8	Inter-Frame Separation Symbol (IFS)	344
21.5.3.9	Idle	344
21.5.4	J1850 VPW Valid/Invalid Bits and Symbols	345
21.5.4.1	Invalid Passive Bit	345
21.5.4.2	Valid Passive Logic 0	345
21.5.4.3	Valid Passive Logic 1	346
21.5.4.4	Valid EOD Symbol	346
21.5.4.5	Valid EOF and IFS Symbols	346
21.5.4.6	Idle Bus	347
21.5.4.7	Invalid Active Bit	348
21.5.4.8	Valid Active Logic 1	348
21.5.4.9	Valid Active Logic 0	348
21.5.4.10	Valid SOF Symbol	349
21.5.4.11	Valid BREAK Symbol	349
21.5.5	Message Arbitration	349
21.6	BDLC Protocol Handler	351
21.6.1	Protocol Architecture	352
21.6.2	Rx and Tx Shift Registers	352
21.6.3	Rx and Tx Shadow Registers	353

21.6.4	Digital Loopback Multiplexer	353
21.6.5	State Machine	353
21.6.5.1	4X Mode	353
21.6.5.2	Receiving a Message in Block Mode	354
21.6.5.3	Transmitting a Message in Block Mode	354
21.6.5.4	J1850 Bus Errors	354
21.6.5.5	Summary	356
21.7	BDLC CPU Interface	357
21.7.1	BDLC Analog and Roundtrip Delay	358
21.7.2	BDLC Control Register 1	359
21.7.3	BDLC Control Register 2	362
21.7.4	BDLC State Vector Register	370
21.7.5	BDLC Data Register	372
21.8	Low-Power Modes	373
21.8.1	Wait Mode	373
21.8.2	Stop Mode	373

Section 22. Timer Interface Module A (TIMA-6)

22.1	Contents	375
22.2	Introduction	376
22.3	Features	376
22.4	Functional Description	380
22.4.1	TIMA Counter Prescaler	380
22.4.2	Input Capture	381
22.4.3	Output Compare	382
22.4.3.1	Unbuffered Output Compare	382
22.4.3.2	Buffered Output Compare	383
22.4.4	Pulse-Width Modulation (PWM)	385
22.4.4.1	Unbuffered PWM Signal Generation	386
22.4.4.2	Buffered PWM Signal Generation	387
22.4.4.3	PWM Initialization	388
22.5	Interrupts	390
22.6	Low-Power Modes	390
22.6.1	Wait Mode	390
22.6.2	Stop Mode	390

22.7	TIMA During Break Interrupts	391
22.8	I/O Signals	391
22.8.1	TIMA Clock Pin (PTD6/ATD14/TCLK)	392
22.8.2	TIMA Channel I/O Pins (PTF3–PTF0/TACH2 and PTE3/TACH1–PTE2/TACH0).	392
22.9	I/O Registers	392
22.9.1	TIMA Status and Control Register	393
22.9.2	TIMA Counter Registers	395
22.9.3	TIMA Counter Modulo Registers	396
22.9.4	TIMA Channel Status and Control Registers	397
22.9.5	TIMA Channel Registers	402

Section 23. Analog-to-Digital Converter (ADC-15)

23.1	Contents	407
23.2	Introduction	408
23.3	Features	408
23.4	Functional Description	408
23.4.1	ADC Port I/O Pins	409
23.4.2	Voltage Conversion	410
23.4.3	Conversion Time	410
23.4.4	Continuous Conversion	411
23.4.5	Accuracy and Precision	411
23.5	Interrupts	411
23.6	Low-Power Modes	411
23.6.1	Wait Mode	411
23.6.2	Stop Mode	412
23.7	I/O Signals	412
23.7.1	ADC Analog Power Pin (V_{DDAREF})/ADC Voltage Reference Pin (V_{REFH}).	412
23.7.2	ADC Analog Ground Pin (V_{SSA})/ADC Voltage Reference Low Pin (V_{REFL})	412
23.7.3	ADC Voltage In (ADCVIN)	412

23.8 I/O Registers 413
 23.8.1 ADC Status and Control Register 413
 23.8.2 ADC Data Register 416
 23.8.3 ADC Input Clock Register 416

Section 24. Electrical Specifications

24.1 Contents 419
 24.2 Maximum Ratings 420
 24.3 Functional Operating Range 421
 24.4 Thermal Characteristics 421
 24.5 5.0 Volt DC Electrical Characteristics 422
 24.6 Control Timing 423
 24.7 ADC Characteristics 424
 24.8 Serial Peripheral Interface (SPI) Timing 425
 24.9 CGM Operating Conditions 428
 24.10 CGM Component Information 428
 24.11 CGM Acquisition/Lock Time Information 429
 24.12 Timer Module Characteristics 429
 24.13 Memory Characteristics 430
 24.14 BDLC Transmitter VPW Symbol Timings 431
 24.15 BDLC Receiver VPW Symbol Timings 431

Section 25. Mechanical Specifications

25.1 Contents 433
 25.2 Introduction 433
 25.3 52-Pin Plastic Leaded Chip Carrier Package 434
 25.4 64-Pin Quad Flat Pack 435

Section 26. Ordering Information

26.1 Contents437
26.2 Introduction437
26.3 MC Order Numbers437

Index

Index439

List of Figures

Figure	Title	Page
1-1	MCU Block Diagram for the MC68HC08ASxx Emulator	36
1-2	MC68HC908AS60 (52-Pin PLCC)	37
1-3	MC68HC908AS60 (64-Pin QFP)	38
1-4	Power Supply Bypassing	39
2-1	Memory Map	48
2-2	Control, Status, and Data Registers	51
4-1	FLASH-1 Control Register (FLCR1)	65
4-2	Smart Programming Algorithm	71
4-3	FLASH-1 Block Protect Register (FLBPR1)	72
4-4	FLASH-2 Block Protect Register (FLBPR2)	73
5-1	FLASH-2 Control Register (FLCR2)	79
5-2	Smart Programming Algorithm	85
6-1	EEPROM-1 Control Register (EECR1).	96
6-2	EEPROM-1 Non-Volatile Register (EENVR1)	98
6-3	EEPROM-1 Array Control Register (EEACR1).	98
7-1	EEPROM-2 Control Register (EECR2).	108
7-2	EEPROM-2 Non-Volatile Register (EENVR2)	110
7-3	EEPROM-2 Array Control Register (EEACR2).	110
8-1	CPU Registers	115
8-2	Accumulator (A)	116
8-3	Index Register (H:X)	116
8-4	Stack Pointer (SP)	117
8-5	Program Counter (PC)	118

Figure	Title	Page
8-6	Condition Code Register (CCR)	119
9-1	SIM Block Diagram	135
9-2	SIM I/O Register Summary	136
9-3	CGM Clock Signals	137
9-4	External Reset Timing	139
9-5	Internal Reset Timing	140
9-6	Sources of Internal Reset	140
9-7	POR Recovery	141
9-8	Interrupt Entry	144
9-9	Interrupt Recovery	144
9-10	Interrupt Processing	145
9-11	Interrupt Recognition Example	147
9-12	Wait Mode Entry Timing	149
9-13	Wait Recovery from Interrupt or Break	149
9-14	Wait Recovery from Internal Reset	149
9-15	Stop Mode Entry Timing	150
9-16	Stop Mode Recovery from Interrupt or Break	150
9-17	SIM Break Status Register (SBSR)	151
9-18	SIM Reset Status Register (SRSR)	153
9-19	SIM Break Flag Control Register (SBFCR)	154
10-1	CGM Block Diagram	158
10-2	I/O Register Summary	159
10-3	CGM External Connections	167
10-4	PLL Control Register (PCTL)	169
10-5	PLL Bandwidth Control Register (PBWC)	171
10-6	PLL Programming Register (PPG)	173
11-1	Configuration Write-Once Register (CONFIG-1)	182
12-1	Break Module Block Diagram	186
12-2	I/O Register Summary	187
12-3	Break Status and Control Register (BSCR)	189
12-4	Break Address Registers (BRKH and BRKL)	190

Figure	Title	Page
13-1	Monitor Mode Circuit.	193
13-2	Monitor Data Format.	195
13-3	Sample Monitor Waveforms	195
13-4	Read Transaction	196
13-5	Break Transaction.	196
13-6	Monitor Mode Entry Timing.	200
14-1	COP Block Diagram	205
14-2	COP Control Register (COPCTL).	207
15-1	LVI Module Block Diagram	210
15-2	LVI I/O Register Summary	211
15-3	LVI Status Register (LVISR).	212
16-1	IRQ Block Diagram	216
16-2	IRQ I/O Register Summary.	217
16-3	IRQ Interrupt Flowchart	218
16-4	IRQ Status and Control Register (ISCR)	220
17-1	SCI Module Block Diagram.	226
17-2	SCI I/O Register Summary	227
17-3	SCI Data Formats.	228
17-4	SCI Transmitter.	229
17-5	SCI Receiver Block Diagram	232
17-6	Receiver Data Sampling	234
17-7	Slow Data	236
17-8	Fast Data	237
17-9	SCI Control Register 1 (SCC1).	243
17-10	SCI Control Register 2 (SCC2).	246
17-11	SCI Control Register 3 (SCC3).	248
17-12	SCI Status Register 1 (SCS1)	250
17-13	Flag Clearing Sequence	252
17-14	SCI Status Register 2 (SCS2)	253
17-15	SCI Data Register (SCDR).	254
17-16	SCI Baud Rate Register (SCBR)	255

List of Figures

Figure	Title	Page
18-1	SPI I/O Register Summary	262
18-2	SPI Module Block Diagram	263
18-3	Full-Duplex Master-Slave Connections	264
18-4	Transmission Format (CPHA = 0)	267
18-5	Transmission Format (CPHA = 1)	268
18-6	Transmission Start Delay (Master)	270
18-7	Missed Read of Overflow Condition	271
18-8	Clearing SPRF When OVRF Interrupt Is Not Enabled	272
18-9	SPI Interrupt Request Generation	275
18-10	SPRF/SPTE CPU Interrupt Timing	276
18-11	CPHA/ \overline{SS} Timing	281
18-12	SPI Control Register (SPCR)	283
18-13	SPI Status and Control Register (SPSCR)	286
18-14	SPI Data Register (SPDR)	289
19-1	TIM Block Diagram	292
19-2	TIM I/O Register Summary	293
19-3	TIM Status and Control Register (TSC)	296
19-4	TIM Counter Registers (TCNTH–TCNTL)	298
19-5	TIM Counter Modulo Registers (TMODH–TMODL)	299
20-1	I/O Port Register Summary	302
20-2	Port A Data Register (PTA)	304
20-3	Data Direction Register A (DDRA)	304
20-4	Port A I/O Circuit	305
20-5	Port B Data Register (PTB)	306
20-6	Data Direction Register B (DDRB)	307
20-7	Port B I/O Circuit	307
20-8	Port C Data Register (PTC)	308
20-9	Data Direction Register C (DDRC)	309
20-10	Port C I/O Circuit	310
20-11	Port D Data Register (PTD)	311
20-12	Data Direction Register D (DDRD)	312
20-13	Port D I/O Circuit	313
20-14	Port E Data Register (PTE)	314
20-15	Data Direction Register E (DDRE)	316

Figure	Title	Page
20-16	Port E I/O Circuit.	317
20-17	Port F Data Register (PTF).	318
20-18	Data Direction Register F (DDRF)	319
20-19	Port F I/O Circuit.	319
20-20	Port G Data Register (PTG)	320
20-21	Data Direction Register G (DDRG).	321
20-22	Port G I/O Circuit	322
20-23	Port H Data Register (PTH)	323
20-24	Data Direction Register H (DDRH)	324
20-25	Port H I/O Circuit.	324
21-1	BDLC Block Diagram	330
21-2	BDLC I/O Register Summary	331
21-3	BDLC Operating Modes State Diagram	332
21-4	BDLC Block Diagram	335
21-5	BDLC Rx Digital Filter Block Diagram	335
21-6	J1850 Bus Message Format (VPW)	338
21-7	J1850 VPW Symbols with Nominal Symbol Times.	343
21-8	J1850 VPW Received Passive Symbol Times	346
21-9	J1850 VPW Received Passive EOF and IFS Symbol Times	347
21-10	J1850 VPW Received Active Symbol Times	348
21-11	J1850 VPW Received BREAK Symbol Times	349
21-12	J1850 VPW Bitwise Arbitrations	350
21-13	BDLC Block Diagram	351
21-14	BDLC Protocol Handler Outline	352
21-15	BDLC Block Diagram	357
21-16	BDLC Analog and Roundtrip Delay Register (BARD)	358
21-17	BDLC Control Register 1 (BCR1)	359
21-18	BDLC Control Register 2 (BCR2)	362
21-19	Types of In-Frame Response (IFR)	366
21-20	BDLC State Vector Register (BSVR)	370
21-21	BDLC Data Register (BDR)	372
22-1	TIMA Block Diagram.	377
22-2	TIMA I/O Register Summary.	378

List of Figures

Figure	Title	Page
22-3	PWM Period and Pulse Width	385
22-4	Timer A Status and Control Register (TASC)	393
22-5	TIMA Counter Registers (TCNTH and TCNTL)	395
22-6	TIMA Counter Modulo Registers (TAMODH and TAMODL)	396
22-7	TIMA Channel Status and Control Registers (TACC0–TASC5)	397
22-8	CHxMAX Latency	402
22-9	TIMA Channel Registers (TACH0H/L–TACH3H/L)	403
23-1	ADC Block Diagram	409
23-2	ADC Status and Control Register (ADSCR)	413
23-3	ADC Data Register (ADR)	416
23-4	ADC Input Clock Register (ADICLK)	416
24-1	SPI Master Timing Diagram	426
24-2	SPI Slave Timing Diagram	427
24-3	BDLC Variable Pulse-Width Modulation (VPW) Symbol Timing	432

List of Tables

Table	Title	Page
1-1	External Pins Summary	43
1-2	Clock Source Summary	45
2-1	Vector Addresses	60
4-1	Charge Pump Clock Frequency	67
4-2	Erase Block Sizes	68
5-1	Charge Pump Clock Frequency	81
5-2	Erase Block Sizes	82
6-1	EEPROM Program/Erase Cycling Reduction	93
6-2	EEPROM Array Address Blocks	94
6-3	EEPROM Program/Erase Mode Select	97
7-1	EEPROM Program/Erase Cycling Reduction	105
7-2	EEPROM Array Address Blocks	106
7-3	EEPROM Program/Erase Mode Select	109
8-1	Instruction Set Summary	123
8-2	Opcode Map	131
9-1	Signal Name Conventions	136
9-2	PIN Bit Set Timing	139
10-1	Variable Definitions	163
10-2	VCO Frequency Multiplier (N) Selection	173
11-1	COP Time Clarification	184

List of Tables

Table	Title	Page
13-1	Mode Selection	194
13-2	Mode Differences	195
13-3	READ (Read Memory) Command	197
13-4	WRITE (Write Memory) Command	197
13-5	IREAD (Indexed Read) Command	198
13-6	IWRITE (Indexed Write) Command	198
13-7	READSP (Read Stack Pointer) Command	198
13-8	RUN (Run User Program) Command	199
13-9	Monitor Baud Rate Selection	199
15-1	LVIOUT Bit Indication	212
17-1	Pin Name Conventions	225
17-2	Start Bit Verification	234
17-3	Data Bit Recovery	235
17-4	Stop Bit Recovery	235
17-5	Character Format Selection	245
17-6	SCI Baud Rate Prescaling	255
17-7	SCI Baud Rate Selection	256
17-8	SCI Baud Rate Selection Examples	257
18-1	Pin Name Conventions	261
18-2	I/O Register Addresses	261
18-3	SPI Interrupts	274
18-4	SPI Configuration	282
18-5	SPI Master Baud Rate Selection	288
19-1	Prescaler Selection	297
20-1	Port A Pin Functions	305
20-2	Port B Pin Functions	308
20-3	Port C Pin Functions	310
20-4	Port D Pin Functions	313
20-5	Port E Pin Functions	317
20-6	Port F Pin Functions	320
20-7	Port G Pin Functions	322

Table	Title	Page
20-8	Port H Pin Functions	325
21-1	BDLC J1850 Bus Error Summary	356
21-2	BDLC Transceiver Delay	359
21-3	BDLC Rate Selection	361
21-4	BDLC Transmit In-Frame Response Control Bit Priority Encoding	365
21-5	BDLC Interrupt Sources	370
22-1	Prescaler Selection	394
22-2	Mode, Edge, and Level Selection	401
23-1	Mux Channel Select	415
23-2	ADC Clock Divide Ratio	417
26-1	MC Order Numbers	437

Freescale Semiconductor, Inc.

Section 1. General Description

1.1 Contents

1.2	Introduction	34
1.3	Features	34
1.4	MCU Block Diagram	35
1.5	Pin Assignments	37
1.5.1	Power Supply Pins (V_{DD} and V_{SS})	39
1.5.2	Oscillator Pins (OSC1 and OSC2)	40
1.5.3	External Reset Pin (\overline{RST})	40
1.5.4	External Interrupt Pin (\overline{IRQ})	40
1.5.5	Analog Power Supply Pin (V_{DDA})	40
1.5.6	Analog Ground Pin (V_{SSA})	40
1.5.7	External Filter Capacitor Pin (CGMXFC)	41
1.5.8	Port A Input/Output (I/O) Pins (PTA7–PTA0)	41
1.5.9	Port B I/O Pins (PTB7/ATD7–PTB0/ATD0)	41
1.5.10	Port C I/O Pins (PTC5–PTC0)	41
1.5.11	Port D I/O Pins (PTD7–PTD0/ATD8)	41
1.5.12	Port E I/O Pins (PTE7/SPSCK–PTE0/TxD)	41
1.5.13	Port F I/O Pins (PTF7–PTF0/TACH2)	42
1.5.14	Port G I/O Pins (PTG2–PTG0)	42
1.5.15	Port H I/O Pins (PTH1–PTH0)	42
1.5.16	BDLC Transmit Pin (BDTxD)	42
1.5.17	BDLC Receive Pin (BDRxD)	42

1.2 Introduction

The MC68HC908AS60 is a member of the low-cost, high-performance M68HC08 Family of 8-bit microcontroller units (MCU). The M68HC08 Family is based on the customer-specified integrated circuit (CSIC) design strategy. All MCUs in the family use the enhanced M68HC08 central processor unit (CPU08) and are available with a variety of modules, memory sizes and types, and package types.

This part is designed to emulate the M68HC08ASxx automotive family.

NOTE: *The MC68HC908AS60 offers extra features which are not available on the MC68HC08AS20 and MC68HC908AS32 devices. It is the user's responsibility to ensure compatibility between the features used on the MC68HC908AS60 and those which are available on the device which will ultimately be used in the application.*

1.3 Features

Features of the MC68HC908AS60 include:

- High-performance M68HC08 architecture
- Fully upward-compatible object code with M6805, M146805, and M68HC05 Families
- 8.4-MHz internal bus frequency
- 60 Kbytes of FLASH electrically erasable read-only memory (FLASH)
- FLASH data security⁽¹⁾
- 1 Kbyte of on-chip electrically erasable programmable read-only memory (EEPROM) with security option
- 2 Kbytes of on-chip random-access memory (RAM)
- Clock generator module (CGM)
- Serial peripheral interface module (SPI)

1. No security feature is absolutely secure. However, Motorola's strategy is to make reading or copying the FLASH/EEPROM difficult for unauthorized users.

- Serial communications interface module (SCI)
- 8-bit, 15-channel analog-to-digital converter (ADC-15)
- 16-bit, 6-channel timer interface module (TIMA-6)
- Modulo timer (TIM)
- SAE J1850 byte data link controller digital module (BDLC-D)
- System protection features:
 - Computer operating properly (COP) with optional reset
 - Low-voltage detection with optional reset
 - Illegal opcode detection with optional reset
 - Illegal address detection with optional reset
- Low-power design with stop and wait modes
- Master reset pin and power-on reset

Features of the CPU08 include:

- Enhanced HC05 programming model
- Extensive loop control functions
- 16 addressing modes (eight more than the M68HC05)
- 16-bit index register and stack pointer
- Memory-to-memory data transfers
- Fast 8×8 multiply instruction
- Fast 16/8 divide instruction
- Binary-coded decimal (BCD) instructions
- Optimization for controller applications
- C language support

1.4 MCU Block Diagram

Figure 1-1 shows the structure of the MC68HC908AS60.

General Description

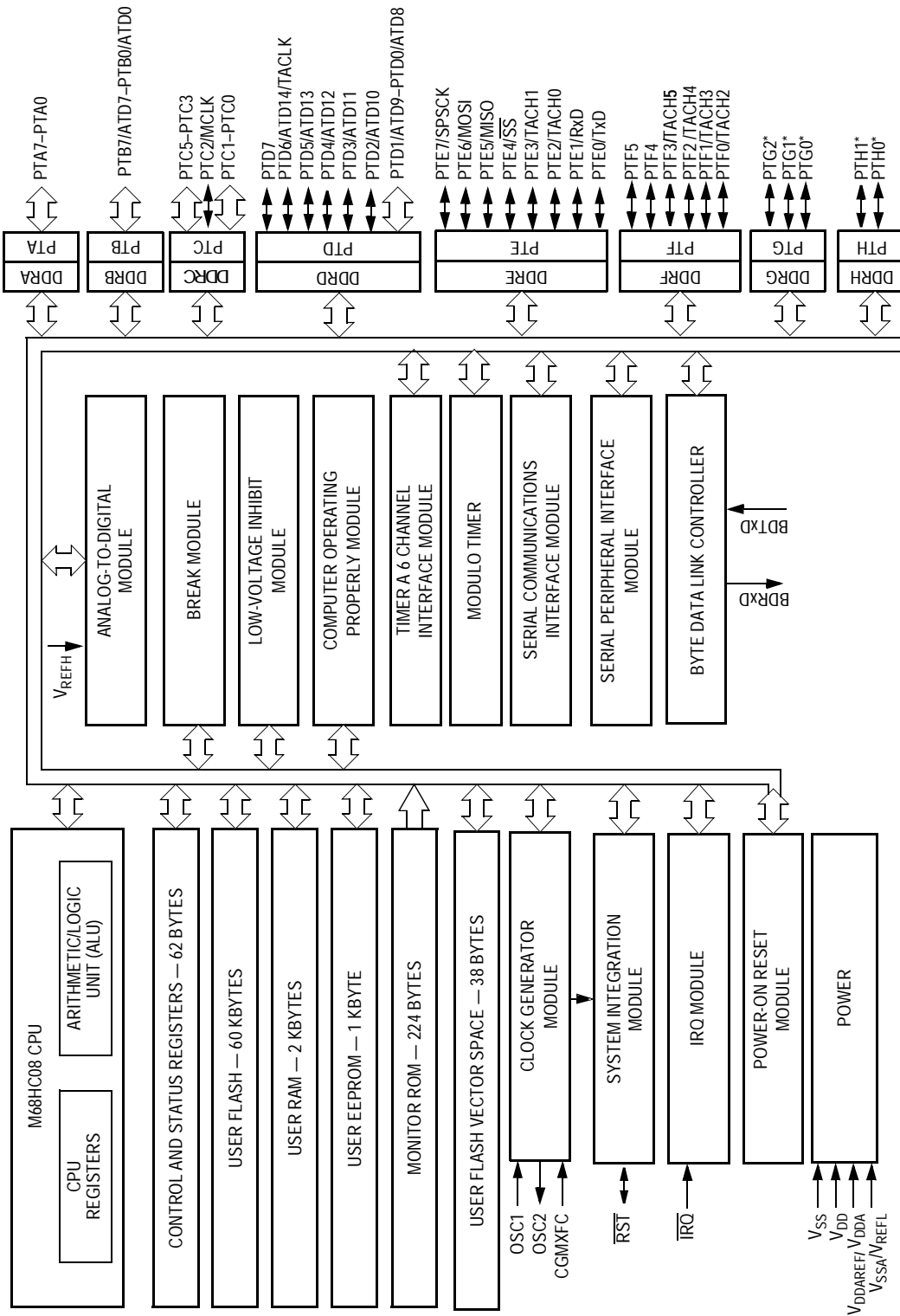

* PTG and PTH pins are available only in 64-pin quad flat packs (QFP).

Figure 1-1. MCU Block Diagram for the MC68HC08ASxx Emulator

1.5 Pin Assignments

Figure 1-2 shows the MC68HC908AS60 pin assignments for the 52-pin plastic leaded chip carrier (PLCC) package.

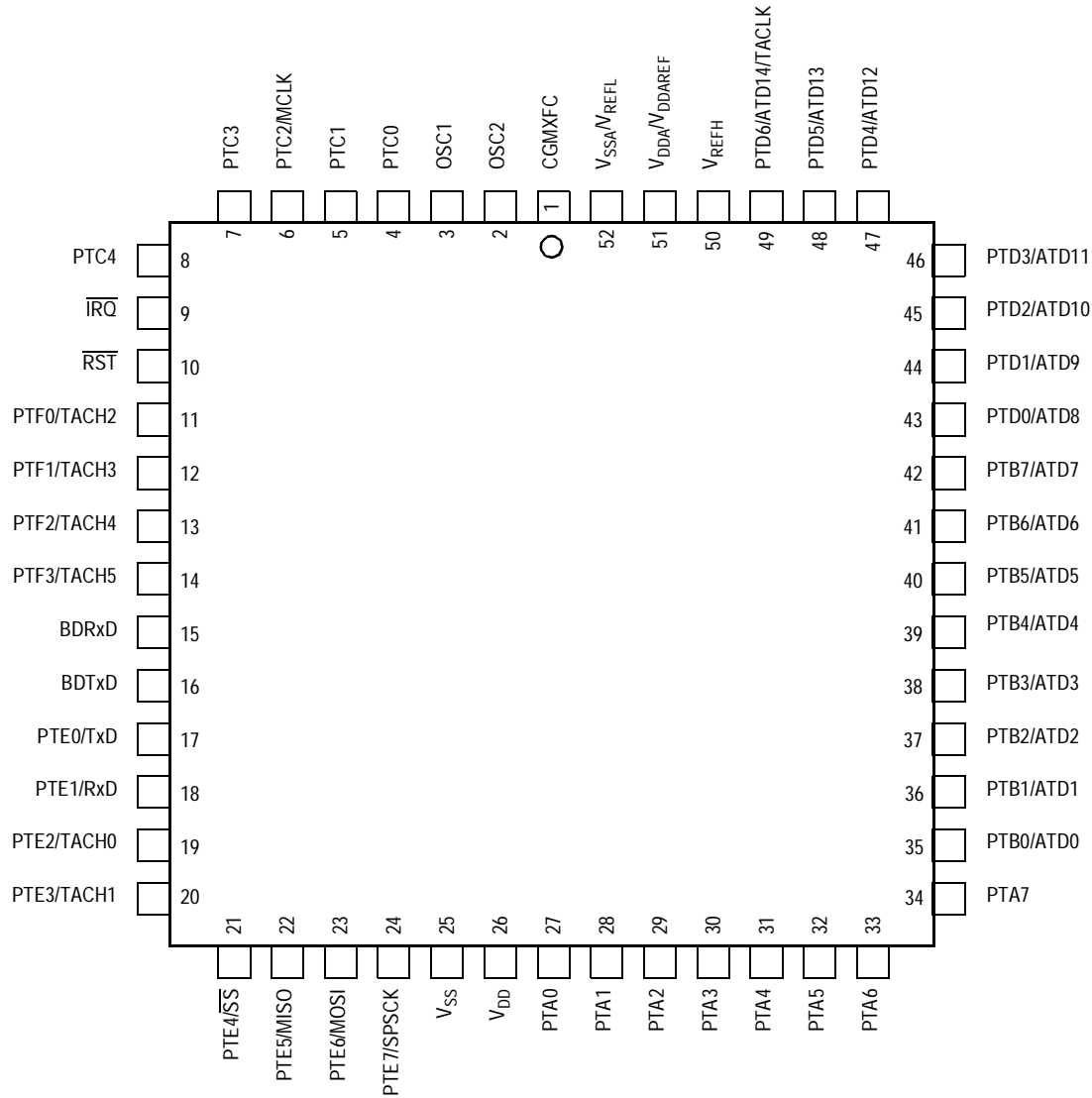

Figure 1-2. MC68HC908AS60 (52-Pin PLCC)

General Description

Figure 1-3 shows the pin assignments for the MC68HC908AS60 64-pin quad flat pack (QFP) package.

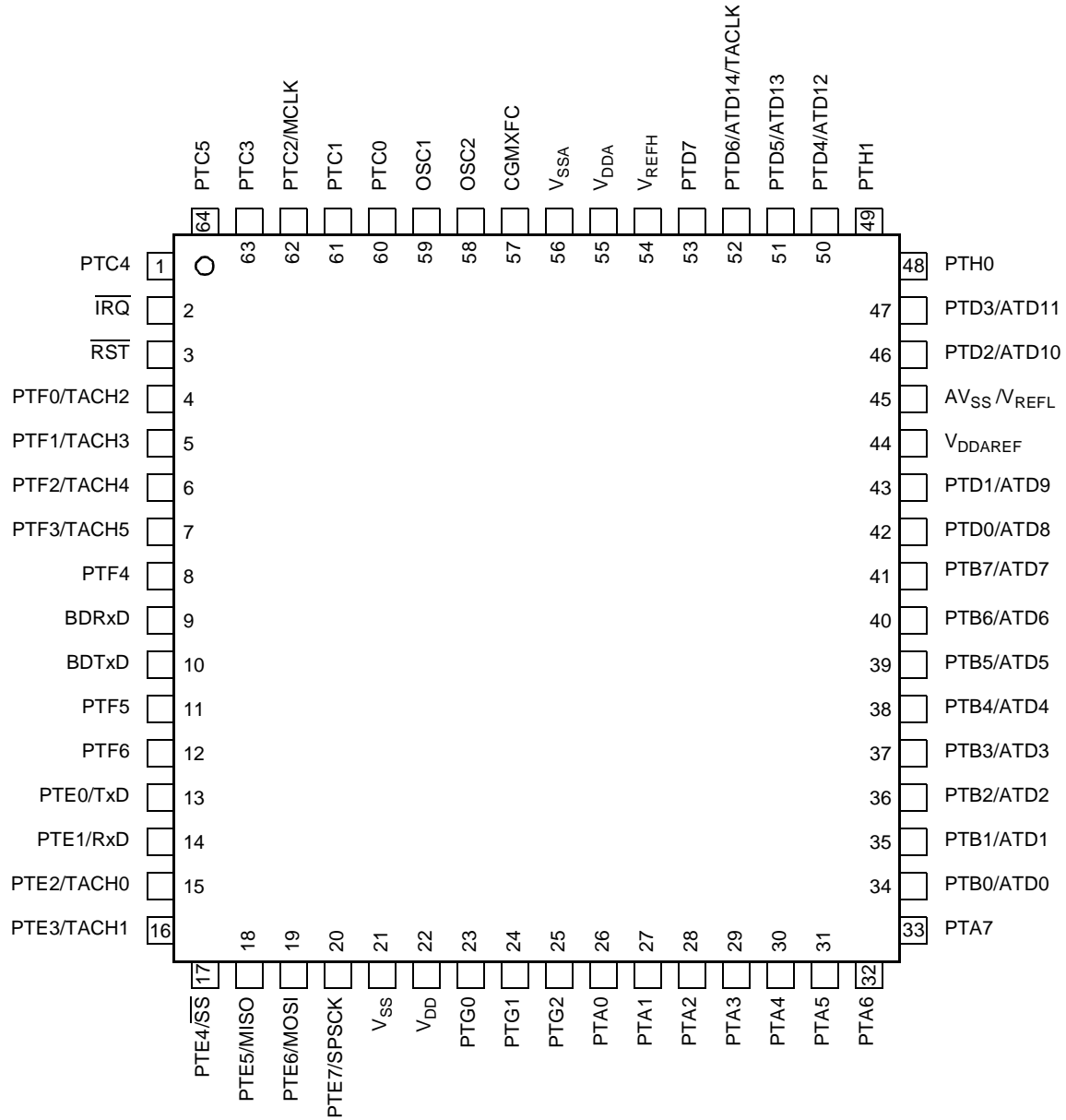

Figure 1-3. MC68HC908AS60 (64-Pin QFP)

NOTE: The following pin descriptions are for quick reference only. For a more detailed representation, see Section 20. Input/Output (I/O) Ports.

1.5.1 Power Supply Pins (V_{DD} and V_{SS})

V_{DD} and V_{SS} are the power supply and ground pins. The MCU operates from a single power supply.

Fast signal transitions on MCU pins place high, short-duration current demands on the power supply. To prevent noise problems, take special care to provide power supply bypassing at the MCU as shown in [Figure 1-4](#). Place the C1 bypass capacitor as close to the MCU as possible. C2 is an optional bulk current bypass capacitor for use in applications that require the port pins to source high current levels.

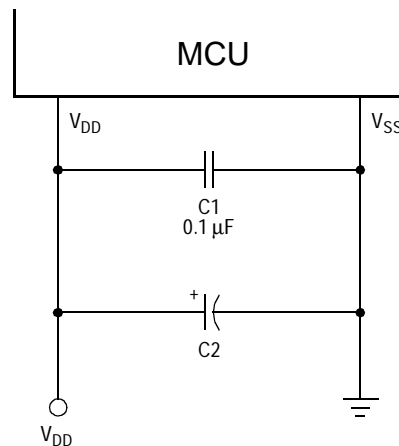

Note: Component values shown represent typical applications.

Figure 1-4. Power Supply Bypassing

V_{SS} is also the ground for the port output buffers and the ground return for the serial clock in the serial peripheral interface module (SPI). See [Section 18. Serial Peripheral Interface \(SPI\)](#).

NOTE: V_{SS} must be grounded for proper MCU operation.

General Description

1.5.2 Oscillator Pins (OSC1 and OSC2)

The OSC1 and OSC2 pins are the connections for the on-chip oscillator circuit. See [Section 10. Clock Generator Module \(CGM\)](#).

1.5.3 External Reset Pin ($\overline{\text{RST}}$)

A logic 0 on the $\overline{\text{RST}}$ pin forces the MCU to a known startup state. $\overline{\text{RST}}$ is bidirectional, allowing a reset of the entire system. It is driven low when any internal reset source is asserted. See [Section 9. System Integration Module \(SIM\)](#) for more information.

1.5.4 External Interrupt Pin ($\overline{\text{IRQ}}$)

$\overline{\text{IRQ}}$ is an asynchronous external interrupt pin. See [Section 16. External Interrupt Module \(IRQ\)](#).

1.5.5 Analog Power Supply Pin (V_{DDA})

V_{DDA} is the power supply pin for the analog portion of the chip. This pin will supply both the clock generator module (CGM) and the analog-to-digital converter (ADC). See [Section 10. Clock Generator Module \(CGM\)](#), and [Section 23. Analog-to-Digital Converter \(ADC-15\)](#).

1.5.6 Analog Ground Pin (V_{SSA})

The V_{SSA} analog ground pin is used only for the ground connections for the analog sections of the circuit and should be decoupled as per the V_{SS} digital ground pin. The analog sections consist of a clock generator module (CGM) and an analog-to-digital converter (ADC). See [Section 10. Clock Generator Module \(CGM\)](#) and [Section 23. Analog-to-Digital Converter \(ADC-15\)](#).

1.5.7 External Filter Capacitor Pin (CGMXFC)

CGMXFC is an external filter capacitor connection for the CGM. See [Section 23. Analog-to-Digital Converter \(ADC-15\)](#).

1.5.8 Port A Input/Output (I/O) Pins (PTA7–PTA0)

PTA7–PTA0 are general-purpose bidirectional input/output (I/O) port pins. See [Section 20. Input/Output \(I/O\) Ports](#).

1.5.9 Port B I/O Pins (PTB7/ATD7–PTB0/ATD0)

Port B is an 8-bit special function port that shares all eight pins with the analog-to-digital converter (ADC). See [Section 23. Analog-to-Digital Converter \(ADC-15\)](#), and [Section 20. Input/Output \(I/O\) Ports](#).

1.5.10 Port C I/O Pins (PTC5–PTC0)

PTC5–PTC3 and PTC1–PTC0 are general-purpose bidirectional I/O port pins. PTC2/MCLK is a special function port that shares its pin with the system clock which has a frequency equivalent to the system clock. See [Section 20. Input/Output \(I/O\) Ports](#).

1.5.11 Port D I/O Pins (PTD7–PTD0/ATD8)

Port D is an 8-bit special-function port that shares seven of its pins with the analog-to-digital converter module (ADC-15) and one of its pins with the timer interface module (TIMA). See [Section 22. Timer Interface Module A \(TIMA-6\)](#), [Section 23. Analog-to-Digital Converter \(ADC-15\)](#), and [Section 20. Input/Output \(I/O\) Ports](#).

1.5.12 Port E I/O Pins (PTE7/SPSCK–PTE0/TxD)

Port E is an 8-bit special function port that shares two of its pins with the timer interface module (TIMA), four of its pins with the serial peripheral interface module (SPI), and two of its pins with the serial communication interface module (SCI). See [Section 17. Serial Communications](#)

[Interface \(SCI\)](#), [Section 18. Serial Peripheral Interface \(SPI\)](#), [Section 22. Timer Interface Module A \(TIMA-6\)](#), and [Section 20. Input/Output \(I/O\) Ports](#).

1.5.13 Port F I/O Pins (PTF7–PTF0/TACH2)

Port F is a 7-bit special function port that shares six of its pins with the timer interface module (TIMA-6). See [Section 22. Timer Interface Module A \(TIMA-6\)](#) and [Section 20. Input/Output \(I/O\) Ports](#).

1.5.14 Port G I/O Pins (PTG2–PTG0)

Port G is a 3-bit, general-purpose, bidirectional I/O port.

1.5.15 Port H I/O Pins (PTH1–PTH0)

Port H is a 2-bit, general-purpose, bidirectional I/O port.

NOTE: *Port G and Port H I/O pins are available only in the 64-pin QFP.*

1.5.16 BDLC Transmit Pin (BDTxD)

This pin is the serial digital output from the BDLC module (BDTxD). See [Section 21. Byte Data Link Controller-Digital \(BDLC-D\)](#).

1.5.17 BDLC Receive Pin (BDRxD)

This pin is the serial digital input to the BDLC module (BDRxD). See [Section 21. Byte Data Link Controller-Digital \(BDLC-D\)](#).

Table 1-1. External Pins Summary

Pin Name	Function	Driver Type	Hysteresis	Reset State
PTA7–PTA0	General-purpose I/O	Dual state	No	Input Hi-Z
PTB7/ATD7–PTB0/ATD0	General-purpose I/O ADC channel	Dual state	No	Input Hi-Z
PTC5–PTC0 PTC5 available in 64-pin package only	General-purpose I/O	Dual state	No	Input Hi-Z
PTD7 Available in 64-pin package only	General-purpose I/O	Dual state	No	Input Hi-Z
PTD6/ATD14/TACLK ADC channel	General-purpose I/O ADC channel/timer external input clock	Dual state	No	Input Hi-Z
PTD5/ATD13 ADC channel	General-purpose I/O ADC channel	Dual state	No	Input Hi-Z
PTD4/ATD12/TBCLK ADC channel TBCLK for 64-pin package only	General-purpose I/O ADC channel/timer external input clock	Dual state	No	Input Hi-Z
PTD3/ATD11–PTD0/ATD8 ADC channel	General-purpose I/O ADC channel	Dual state	No	Input Hi-Z
PTE7/SPSCK	General-purpose I/O SPI clock	Dual state open drain	Yes	Input Hi-Z
PTE6/MOSI	General-purpose I/O SPI data path	Dual state open drain	Yes	Input Hi-Z
PTE5/MISO	General-purpose I/O SPI data path	Dual state open drain	Yes	Input Hi-Z
PTE4/ \overline{SS}	General-purpose I/O SPI slave select	Dual state	Yes	Input Hi-Z
PTE3/TACH1	General-purpose I/O timer channel 1	Dual state	Yes	Input Hi-Z
PTE2/TACH0	General-purpose I/O timer channel 0	Dual state	Yes	Input Hi-Z
PTE1/RxD	General-purpose I/O SCI receive data	Dual state	Yes	Input Hi-Z
PTE0/TxD	General-purpose I/O SCI transmit data	Dual state	No	Input Hi-Z
PTF6 Available in 64-pin package only	General-purpose I/O	Dual state	No	Input Hi-Z
PTF5/TBCH1–PTF4/TBCH0 Available in 64-pin package only	General-purpose I/O timer B channel	Dual state	Yes	Input Hi-Z

General Description

Table 1-1. External Pins Summary (Continued)

Pin Name	Function	Driver Type	Hysteresis	Reset State
PTF3/TACH5	General-purpose I/O timer A channel 5	Dual state	Yes	Input Hi-Z
PTF2/TACH4	General-purpose I/O timer A channel 4	Dual state	Yes	Input Hi-Z
PTF1/TACH3	General-purpose I/O timer A channel 3	Dual state	Yes	Input Hi-Z
PTF0/TACH2	General-purpose I/O timer A channel 2	Dual state	Yes	Input Hi-Z
PTG2–PTG0 Available in 64-pin package only	General-purpose I/O	Dual state	Yes	Input Hi-Z
PTH1–PTH0 Available in 64-pin package only	General-purpose I/O	Dual state	Yes	Input Hi-Z
V _{DD}	Chip power supply	N/A	N/A	N/A
V _{SS}	Chip ground	N/A	N/A	N/A
V _{DDA} /V _{DDAREF} ADC reference voltage for 52-pin package only	Analog power supply	N/A	N/A	N/A
V _{SSA} /V _{REFL} V _{REFL} Available in 52-pin package only	Analog ground/ADC reference voltage	N/A	N/A	N/A
A _{VDD} /V _{DDAREF} Available in 64-pin package only	ADC power supply/ADC reference voltage	N/A	N/A	N/A
A _{VSS} /V _{REFL} Available in 64-pin package only	ADC ground/ADC reference voltage	N/A	N/A	N/A
V _{REFH}	A/D reference voltage	N/A	N/A	N/A
OSC1	External clock in	N/A	N/A	Input Hi-Z
OSC2	External clock out	N/A	N/A	Output
CGMXFC	PLL filter cap	N/A	N/A	N/A
$\overline{\text{IRQ}}$	External interrupt request	N/A	N/A	Input Hi-Z
$\overline{\text{RST}}$	Reset	N/A	N/A	Output low
BDRxD	BDLC-D serial input	N/A	No	Input Hi-Z
BDTxD	BDLC-D serial output	Output	No	Output low

Table 1-2. Clock Source Summary

Module	Clock Source
ADC	CGMXCLK or bus clock
BDLC	CGMXCLK
COP	CGMXCLK
CPU	Bus clock
EEPROM	RC OSC or bus clock
SPI	Bus clock/SPSCK
SCI	CGMXCLK
TIMA-6	Bus clock or PTD6/ATD14/TACLK
TIM	Bus clock
SIM	CGMOUT and CGMXCLK
IRQ	Bus clock
BRK	Bus clock
LVI	Bus clock
CGM	OSC1 and OSC2

Section 2. Memory Map

2.1 Contents

2.2	Introduction	47
2.3	Input/Output Section	50

2.2 Introduction

The CPU08 can address 64 Kbytes of memory space. The memory map, shown in **Figure 2-1**, includes:

- 60 Kbytes of FLASH EEPROM
- 2048 bytes of RAM
- 1024 bytes of EEPROM with protect option
- 38 bytes of user-defined vectors
- 224 bytes of monitor ROM

These definitions apply to the memory map representation of reserved and unimplemented locations.

- Reserved — Accessing a reserved location can have unpredictable effects on MCU operation.
- Unimplemented — Accessing an unimplemented location causes an illegal address reset.

Memory Map

Freescale Semiconductor, Inc.

\$0000 ↓	I/O REGISTERS 64 BYTES	\$0000 ↓
\$003F ↓	UNIMPLEMENTED 11 BYTES	\$003F ↓
\$0040 ↓	I/O REGISTERS 5 BYTES	\$0040 ↓
\$004A ↓	RAM-1 1024 BYTES	\$004A ↓
\$004B ↓	FLASH-2 432 BYTES	\$004B ↓
\$004F ↓	EEPROM-2 512 BYTES	\$004F ↓
\$0050 ↓	EEPROM-1 512 BYTES	\$0050 ↓
\$044F ↓	RAM-2 1024 BYTES	\$044F ↓
\$0450 ↓	FLASH-2 29,184 BYTES	\$0450 ↓
\$05FF ↓	FLASH-1 32,256 BYTES	\$05FF ↓
\$0600 ↓	SIM BREAK STATUS REGISTER (SBSR)	\$0600 ↓
\$07FF ↓	SIM RESET STATUS REGISTER (SRSR)	\$07FF ↓
\$0800 ↓	RESERVED	\$0800 ↓
\$09FF ↓	SIM BREAK FLAG CONTROL REGISTER (SBFCR)	\$09FF ↓
\$0A00 ↓	RESERVED	\$0A00 ↓
\$0DFF ↓	RESERVED	\$0DFF ↓
\$0E00 ↓	UNIMPLEMENTED	\$0E00 ↓
\$7FFF ↓	RESERVED	\$7FFF ↓
\$8000 ↓	RESERVED	\$8000 ↓
\$FDFF ↓	RESERVED	\$FDFF ↓
\$FE00	RESERVED	\$FE00
\$FE01	RESERVED	\$FE01
\$FE02	RESERVED	\$FE02
\$FE03	RESERVED	\$FE03
\$FE04	RESERVED	\$FE04
\$FE05	RESERVED	\$FE05
\$FE06	RESERVED	\$FE06
\$FE07	RESERVED	\$FE07
\$FE08	RESERVED	\$FE08
\$FE09	RESERVED	\$FE09
\$FE0A	RESERVED	\$FE0A

Figure 2-1. Memory Map

\$FE0B	FLASH CONTROL REGISTER (FLCR1)	\$FE0B
\$FE0C	BREAK ADDRESS REGISTER HIGH (BRKH)	\$FE0C
\$FE0D	BREAK ADDRESS REGISTER LOW (BRKL)	\$FE0D
\$FE0E	BREAK STATUS AND CONTROL REGISTER (BSCR)	\$FE0E
\$FE0F	LVI STATUS REGISTER (LVISR)	\$FE0F
\$FE10	RESERVED	\$FE10
\$FE11	FLASH CONTROL REGISTER (FLCR2)	\$FE11
\$FE12	UNIMPLEMENTED 6 BYTES	\$FE12
↓		↓
\$FE17		\$FE17
\$FE18	EEPROM NON-VOLATILE REGISTER (EENVR2)	\$FE18
\$FE19	EEPROM CONTROL REGISTER (EECR2)	\$FE19
\$FE1A	RESERVED	\$FE1A
\$FE1B	EEPROM ARRAY CONFIGURATION (EEACR2)	\$FE1B
\$FE1C	EEPROM NON-VOLATILE REGISTER (EENVR1)	\$FE1C
\$FE1D	EEPROM CONTROL REGISTER (EECR1)	\$FE1D
\$FE1E	RESERVED	\$FE1E
\$FE1F	EEPROM ARRAY CONFIGURATION (EEACR1)	\$FE1F
\$FE20	MONITOR ROM 224 BYTES	\$FE20
↓		↓
\$FEFF		\$FEFF
\$FF00	UNIMPLEMENTED 128 BYTES	\$FF00
↓		↓
\$FF7F		\$FF7F
\$FF80	FLASH BLOCK PROTECT REGISTER (FLBPR1)	\$FF80
\$FF81	FLASH BLOCK PROTECT REGISTER (FLBPR2)	\$FF81
\$FF82	RESERVED 74 BYTES	\$FF82
↓		↓
\$FFCB		\$FFCB
\$FFCC	RESERVED 14 BYTES	\$FFCC
↓		↓
\$FFD9		\$FFD9
\$FFDA	VECTORS 38 BYTES	\$FFDA
↓		↓
\$FFFF		\$FFFF

Figure 2-1. Memory Map (Continued)

2.3 Input/Output Section

Addresses \$0000–\$003F, shown in [Figure 2-2](#), contain most of the control, status, and data registers. Additional input/output (I/O) registers have these addresses:

- \$FE00 — SIM break status register, SBSR
- \$FE01 — SIM reset status register, SRSR
- \$FE03 — SIM break flag control register, SBFCR
- \$FE0B — FLASH control register, FLCR1
- \$FE0C — Break address register high, BRKH
- \$FE0D — Break address register low, BRKL
- \$FE0E — Break status and control register, BRKSCR
- \$FE0F — LVI status register, LVISR
- \$FE11 — FLASH control register, FLCR2
- \$FE18 — EEPROM non-volatile register, EENVR2
- \$FE19 — EEPROM control register, EECR2
- \$FE1B — EEPROM array configuration register, EEACR2
- \$FE1C — EEPROM non-volatile register, EENVR1
- \$FE1D — EEPROM control register, EECR1
- \$FE1F — EEPROM array configuration register, EEACR1
- \$FF80 — FLASH block protect register, FLBPR1
- \$FF81 — FLASH block protect register, FLBPR2
- \$FFFF — COP control register, COPCTL

[Table 2-1](#) is a list of vector locations.

Addr.	Register Name	Bit 7	6	5	4	3	2	1	Bit 0	
\$0000	Port A Data Register (PTA) See page 304.	Read:	PTA7	PTA6	PTA5	PTA4	PTA3	PTA2	PTA1	PTA0
		Write:								
		Reset:	Unaffected by reset							
\$0001	Port B Data Register (PTB) See page 306.	Read:	PTB7	PTB6	PTB5	PTB4	PTB3	PTB2	PTB1	PTB0
		Write:								
		Reset:	Unaffected by reset							
\$0002	Port C Data Register (PTC) See page 308.	Read:	0	0	PTC5	PTC4	PTC3	PTC2	PTC1	PTC0
		Write:	R	R						
		Reset:	Unaffected by reset							
\$0003	Port D Data Register (PTD) See page 311.	Read:	PTD7	PTD6	PTD5	PTD4	PTD3	PTD2	PTD1	PTD0
		Write:								
		Reset:	Unaffected by reset							
\$0004	Data Direction Register A (DDRA) See page 304.	Read:	DDRA7	DDRA6	DDRA5	DDRA4	DDRA3	DDRA2	DDRA1	DDRA0
		Write:								
		Reset:	Unaffected by reset							
\$0005	Data Direction Register B (DDRB) See page 307.	Read:	DDRB7	DDRB6	DDRB5	DDRB4	DDRB3	DDRB2	DDRB1	DDRB0
		Write:								
		Reset:	0	0	0	0	0	0	0	0
\$0006	Data Direction Register C (DDRC) See page 309.	Read:	MCLKEN	0	DDRC5	DDRC4	DDRC3	DDRC2	DDRC1	DDRC0
		Write:		R						
		Reset:	0	0	0	0	0	0	0	0
\$0007	Data Direction Register D (DDRD) See page 312.	Read:	DDRD7	DDRD6	DDRD5	DDRD4	DDRD3	DDRD2	DDRD1	DDRD0
		Write:								
		Reset:	0	0	0	0	0	0	0	0
\$0008	Port E Data Register (PTE) See page 314.	Read:	PTE7	PTE6	PTE5	PTE4	PTE3	PTE2	PTE1	PTE0
		Write:								
		Reset:	Unaffected by reset							
\$0009	Port F Data Register (PTF) See page 318.	Read:	0	PTF6	PTF5	PTF4	PTF3	PTF2	PTF1	PTF0
		Write:	R							
		Reset:	Unaffected by reset							

 = Unimplemented  = Reserved U = Unaffected

Figure 2-2. Control, Status, and Data Registers (Sheet 1 of 9)

Memory Map

Addr.	Register Name		Bit 7	6	5	4	3	2	1	Bit 0
\$000A	Port G Data Register (PTG) See page 320.	Read:	0	0	0	0	0	PTG2	PTG1	PTG0
		Write:	R	R	R	R	R			
		Reset:	Unaffected by reset							
\$000B	Port H Data Register (PTH) See page 323.	Read:	0	0	0	0	0	0	PTH1	PTH0
		Write:	R	R	R	R	R	R		
		Reset:	Unaffected by reset							
\$000C	Data Direction Register E (DDRE) See page 316.	Read:	DDRE7	DDRE6	DDRE5	DDRE4	DDRE3	DDRE2	DDRE1	DDRE0
		Write:								
		Reset:	0	0	0	0	0	0	0	0
\$000D	Data Direction Register F (DDRF) See page 319.	Read:	0	DDRF6	DDRF5	DDRF4	DDRF3	DDRF2	DDRF1	DDRF0
		Write:	R							
		Reset:	0	0	0	0	0	0	0	0
\$000E	Data Direction Register G (DDRG) See page 321.	Read:	0	0	0	0	0	DDRG2	DDRG1	DDRG0
		Write:	R	R	R	R	R			
		Reset:	0	0	0	0	0	0	0	0
\$000F	Data Direction Register H (DDRH) See page 324.	Read:	0	0	0	0	0	0	DDRH1	DDRH0
		Write:	R	R	R	R	R	R		
		Reset:	0	0	0	0	0	0	0	0
\$0010	SPI Control Register (SPCR) See page 283.	Read:	SPRIE	R	SPMSTR	CPOL	CPHA	SPWOM	SPE	SPTIE
		Write:								
		Reset:	0	0	1	0	1	0	0	0
\$0011	SPI Status and Control Register (SPSCR) See page 286.	Read:	SPRF	ERRIE	OVRF	MODF	SPTIE	MODFEN	SPR1	SPR0
		Write:	R		R	R	R			
		Reset:	0	0	0	0	1	0	0	0
\$0012	SPI Data Register (SPDR) See page 289.	Read:	R7	R6	R5	R4	R3	R2	R1	R0
		Write:	T7	T6	T5	T4	T3	T2	T1	T0
		Reset:	Indeterminate after reset							
\$0013	SCI Control Register 1 (SCC1) See page 243.	Read:	LOOPS	ENSCI	TXINV	M	WAKE	ILTY	PEN	PTY
		Write:								
		Reset:	0	0	0	0	0	0	0	0

= Unimplemented R = Reserved U = Unaffected

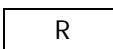
Figure 2-2. Control, Status, and Data Registers (Sheet 2 of 9)

Addr.	Register Name	Bit 7	6	5	4	3	2	1	Bit 0	
\$0014	SCI Control Register 2 (SCC2) See page 246.	Read:	SCTIE	TCIE	SCRIE	ILIE	TE	RE	RWU	SBK
		Write:								
		Reset:	0	0	0	0	0	0	0	0
\$0015	SCI Control Register 3 (SCC3) See page 248.	Read:	R8	T8	R	R	ORIE	NEIE	FEIE	PEIE
		Write:								
		Reset:	U	U	0	0	0	0	0	0
\$0016	SCI Status Register 1 (SCS1) See page 250.	Read:	SCTE	TC	SCRf	IDLE	OR	NF	FE	PE
		Write:								
		Reset:	1	1	0	0	0	0	0	0
\$0017	SCI Status Register 2 (SCS2) See page 253.	Read:							BKF	RPF
		Write:								
		Reset:	0	0	0	0	0	0	0	0
\$0018	SCI Data Register (SCDR) See page 254.	Read:	R7	R6	R5	R4	R3	R2	R1	R0
		Write:	T7	T6	T5	T4	T3	T2	T1	T0
		Reset:	Unaffected by reset							
\$0019	SCI Baud Rate Register (SCBR) See page 255.	Read:			SCP1	SCP0	R	SCR2	SCR1	SCR0
		Write:								
		Reset:	0	0	0	0	0	0	0	0
\$001A	IRQ Status and Control Register (ISCR) See page 220.	Read:	0	0	0	0	IRQF1	0	IMASK1	MODE1
		Write:	R	R	R	R	R	ACK1		
		Reset:	0	0	0	0	0	0	0	0
\$001B	Unimplemented									
\$001C	PLL Control Register (PCTL) See page 169.	Read:	PLLIE	PLLf	PLLON	BCS	1	1	1	1
		Write:								
		Reset:	0	0	1	0	1	1	1	1
\$001D	PLL Bandwidth Control Register (PBWC) See page 171.	Read:	AUTO	LOCK	ACQ	XLD	0	0	0	0
		Write:								
		Reset:	0	0	0	0	0	0	0	0
\$001E	PLL Programming Register (PPG) See page 173.	Read:	MUL7	MUL6	MUL5	MUL4	VRS7	VRS6	VRS5	VRS4
		Write:								
		Reset:	0	1	1	0	0	1	1	0

= Unimplemented
 R = Reserved
 U = Unaffected

Figure 2-2. Control, Status, and Data Registers (Sheet 3 of 9)

Memory Map

Addr.	Register Name	Bit 7	6	5	4	3	2	1	Bit 0
\$001F	Configuration Write-Once Register (CONFIG-1) See page 182.	Read: LVISTOP Write: R Reset: 0	R 1	LVIRST 1	LVIPWR 1	SSREC 0	COPL 0	STOP 0	COPD 0
\$0020	Timer A Status and Control Register (TASC) See page 393.	Read: TOF Write: 0 Reset: 0	TOIE 0	TSTOP 1	0 TRST 0	0 R 0	PS2 0	PS1 0	PS0 0
\$0021	Unimplemented								
\$0022	Timer A Counter Register High (TACNTH) See page 395.	Read: Bit 15 Write: R Reset: 0	14 R 0	13 R 0	12 R 0	11 R 0	10 R 0	9 R 0	Bit 8 R 0
\$0023	Timer A Counter Register Low (TACNTL) See page 395.	Read: Bit 7 Write: R Reset: 0	6 R 0	5 R 0	4 R 0	3 R 0	2 R 0	1 R 0	Bit 0 R 0
\$0024	Timer A Modulo Register High (TAMODH) See page 396.	Read: Bit 15 Write: R Reset: 1	14 R 1	13 R 1	12 R 1	11 R 1	10 R 1	9 R 1	Bit 8 R 1
\$0025	Timer A Modulo Register Low (TAMODL) See page 396.	Read: Bit 7 Write: R Reset: 1	6 R 1	5 R 1	4 R 1	3 R 1	2 R 1	1 R 1	Bit 0 R 1
\$0026	Timer A Channel 0 Status and Control Register (TASC0) See page 397.	Read: CH0F Write: 0 Reset: 0	CH0IE 0	MS0B 0	MS0A 0	ELS0B 0	ELS0A 0	TOV0 0	CH0MAX 0
\$0027	Timer A Channel 0 Register High (TACH0H) See page 403.	Read: Bit 15 Write: R Reset: Indeterminate after reset	14 R	13 R	12 R	11 R	10 R	9 R	Bit 8 R
\$0028	Timer A Channel 0 Register Low (TACH0L) See page 403.	Read: Bit 7 Write: R Reset: Indeterminate after reset	6 R	5 R	4 R	3 R	2 R	1 R	Bit 0 R
\$0029	Timer A Channel 1 Status and Control Register (TASC1) See page 397.	Read: CH1F Write: 0 Reset: 0	CH1IE 0	0 R 0	MS1A 0	ELS1B 0	ELS1A 0	TOV1 0	CH1MAX 0

= Unimplemented
 R = Reserved
 U = Unaffected

Figure 2-2. Control, Status, and Data Registers (Sheet 4 of 9)

Addr.	Register Name	Bit 7	6	5	4	3	2	1	Bit 0	
\$002A	Timer A Channel 1 Register High (TACH1H) See page 403.	Read:	Bit 15	14	13	12	11	10	9	Bit 8
		Write:								
		Reset:	Indeterminate after reset							
\$002B	Timer A Channel 1 Register Low (TACH1L) See page 403.	Read:	Bit 7	6	5	4	3	2	1	Bit 0
		Write:								
		Reset:	Indeterminate after reset							
\$002C	Timer A Channel 2 Status and Control Register (TASC2) See page 397.	Read:	CH2F	CH2IE	MS2B	MS2A	ELS2B	ELS2A	TOV2	CH2MAX
		Write:	0							
		Reset:	0	0	0	0	0	0	0	0
\$002D	Timer A Channel 2 Register High (TACH2H) See page 403.	Read:	Bit 15	14	13	12	11	10	9	Bit 8
		Write:								
		Reset:	Indeterminate after reset							
\$002E	Timer A Channel 2 Register Low (TACH2L) See page 403.	Read:	Bit 7	6	5	4	3	2	1	Bit 0
		Write:								
		Reset:	Indeterminate after reset							
\$002F	Timer A Channel 3 Status and Control Register (TASC3) See page 397.	Read:	CH3F	CH3IE	0	MS3A	ELS3B	ELS3A	TOV3	CH3MAX
		Write:	0		R					
		Reset:	0	0	0	0	0	0	0	0
\$0030	Timer A Channel 3 Register High (TACH3H) See page 403.	Read:	Bit 15	14	13	12	11	10	9	Bit 8
		Write:								
		Reset:	Indeterminate after reset							
\$0031	Timer A Channel 3 Register Low (TACH3L) See page 403.	Read:	Bit 7	6	5	4	3	2	1	Bit 0
		Write:								
		Reset:	Indeterminate after reset							
\$0032	Timer A Channel 4 Status and Control Register (TASC4) See page 397.	Read:	CH4F	CH4IE	MS4B	MS4A	ELS4B	ELS4A	TOV4	CH4MAX
		Write:	0							
		Reset:	0	0	0	0	0	0	0	0
\$0033	Timer A Channel 4 Register High (TACH4H) See page 403.	Read:	Bit 15	14	13	12	11	10	9	Bit 8
		Write:								
		Reset:	Indeterminate after reset							

 = Unimplemented  = Reserved U = Unaffected

Figure 2-2. Control, Status, and Data Registers (Sheet 5 of 9)

Memory Map

Addr.	Register Name		Bit 7	6	5	4	3	2	1	Bit 0
\$0034	Timer A Channel 4 Register Low (TACH4L) See page 403.	Read:	Bit 7	6	5	4	3	2	1	Bit 0
		Write:	Bit 7	6	5	4	3	2	1	Bit 0
		Reset:	Indeterminate after reset							
\$0035	Timer A Channel 5 Status and Control Register (TASC5) See page 397.	Read:	CH5F	CH5IE	0	MS5A	ELS5B	ELS5A	TOV5	CH5MAX
		Write:	0		R					
		Reset:	0	0	0	0	0	0	0	0
\$0036	Timer A Channel 5 Register High (TACH5H) See page 403.	Read:	Bit 15	14	13	12	11	10	9	Bit 8
		Write:	Bit 15	14	13	12	11	10	9	Bit 8
		Reset:	Indeterminate after reset							
\$0037	Timer A Channel 5 Register Low (TACH5L) See page 403.	Read:	Bit 7	6	5	4	3	2	1	Bit 0
		Write:	Bit 7	6	5	4	3	2	1	Bit 0
		Reset:	Indeterminate after reset							
\$0038	Analog-to-Digital Status and Control Register (ADSCR) See page 413.	Read:	COCO	AIEN	ADCO	ADCH4	ADCH3	ADCH2	ADCH1	ADCH0
		Write:	R							
		Reset:	0	0	0	1	1	1	1	1
\$0039	Analog-to-Digital Data Register (ADR) See page 416.	Read:	AD7	AD6	AD5	AD4	AD3	AD2	AD1	AD0
		Write:	R	R	R	R	R	R	R	R
		Reset:	Indeterminate after reset							
\$003A	Analog-to-Digital Input Clock Register (ADICLK) See page 416.	Read:	ADIV2	ADIV1	ADIV0	ADICLK	0	0	0	0
		Write:					R	R	R	R
		Reset:	0	0	0	0	0	0	0	0
\$003B	BDLC Analog and Roundtrip Delay Register (BARD) See page 358.	Read:	ATE	RXPOL	0	0	BO3	BO2	BO1	BO0
		Write:								
		Reset:	1	1	0	0	0	1	1	1
\$003C	BDLC Control Register 1 (BCR1) See page 359.	Read:	IMSG	CLKS	R1	R0	0	0	IE	WCM
		Write:					R	R		
		Reset:	1	1	1	0	0	0	0	0
\$003D	BDLC Control Register 2 (BCR2) See page 362.	Read:	ALOOP	DLOOP	RX4XE	NBFS	TEOD	TSIFR	TMIFR1	TMIFR0
		Write:								
		Reset:	1	1	0	0	0	0	0	0

 = Unimplemented  = Reserved U = Unaffected

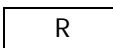
Figure 2-2. Control, Status, and Data Registers (Sheet 6 of 9)

Addr.	Register Name		Bit 7	6	5	4	3	2	1	Bit 0	
\$003E	BDLC State Vector Register (BSVR) See page 370.	Read:	0	0	I3	I2	I1	I0	0	0	
		Write:									
		Reset:	0	0	0	0	0	0	0	0	0
\$003F	BDLC Data Register (BDR) See page 372.	Read:	BD7	BD6	BD5	BD4	BD3	BD2	BD1	BD0	
		Write:									
		Reset:	Indeterminate after reset								
\$0040 ↓ \$004A	Unimplemented										
\$004B	TIM Status and Control Register (TSC) See page 296.	Read:	TOF	TOIE	TSTOP	0	0	PS2	PS1	PS0	
		Write:	0			TRST					
		Reset:	0	0	1	0	0	0	0	0	0
\$004C	TIM Counter Register High (TCNTH) See page 298.	Read:	Bit 15	14	13	12	11	10	9	Bit 8	
		Write:									
		Reset:	0	0	0	0	0	0	0	0	0
\$004D	TIM Counter Register Low (TCNTL) See page 298.	Read:	Bit 7	6	5	4	3	2	1	Bit 0	
		Write:									
		Reset:	0	0	0	0	0	0	0	0	0
\$004E	TIM Modulo Register High (TMODH) See page 299.	Read:	Bit 15	14	13	12	11	10	9	Bit 8	
		Write:									
		Reset:	1	1	1	1	1	1	1	1	1
\$004F	TIM Modulo Register Low (TMDL) See page 299.	Read:	Bit 7	6	5	4	3	2	1	Bit 0	
		Write:									
		Reset:	1	1	1	1	1	1	1	1	1
\$FE00	SIM Break Status Register (SBSR) See page 151.	Read:	R	R	R	R	R	R	SBSW	R	
		Write:	R	R	R	R	R	R	See Note		
		Reset:	0								
Note: Writing a logic 0 clears SBSW.											
\$FE01	SIM Reset Status Register (SRSR) See page 153.	Read:	POR	PIN	COP	ILOP	ILAD	0	LVI	0	
		Write:									
		Reset:	1	0	0	0	0	0	0	0	0
			☐	= Unimplemented			☐ R	= Reserved		U = Unaffected	

Figure 2-2. Control, Status, and Data Registers (Sheet 7 of 9)

Memory Map

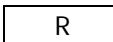
Addr.	Register Name		Bit 7	6	5	4	3	2	1	Bit 0
\$FE03	SIM Break Flag Control Register (SBFCR) See page 154.	Read: Write: Reset:	BCFE	R	R	R	R	R	R	R
\$FE09	Reserved		R	R	R	R	R	R	R	R
\$FE0B	FLASH-1 Control Register (FLCR1) See page 65.	Read: Write: Reset:	FDIV1	FDIV0	BLK1	BLK0	HVEN	MARGIN	ERASE	PGM
\$FE0C	Break Address Register High (BRKH) See page 190.	Read: Write: Reset:	Bit 15	14	13	12	11	10	9	Bit 8
\$FE0D	Break Address Register Low (BRKL) See page 190.	Read: Write: Reset:	Bit 7	6	5	4	3	2	1	Bit 0
\$FE0E	Break Status and Control Register (BSCR) See page 189.	Read: Write: Reset:	BRKE	BRKA	0	0	0	0	0	0
\$FE0F	LVI Status Register (LVISR) See page 212.	Read: Write: Reset:	LVIOUT	0	0	0	0	0	0	0
\$FE11	FLASH-2 Control Register (FLCR2) See page 79.	Read: Write: Reset:	FDIV1	FDIV0	BLK1	BLK0	HVEN	MARGIN	ERASE	PGM
\$FE18	EEPROM-2 Non-volatile Register (EENVR2) See page 110.	Read: Write: Reset:	EERA	CON2	CON1	EEPRTCT	EEBP3	EEBP2	EEBP1	EEBP0
\$FE19	EEPROM-2 Control Register (EECR2) See page 108.	Read: Write: Reset:	EEBCLK	0	EEOFF	EERAS1	EERAS0	EELAT	0	EEPGM
\$FE1A	Reserved		R	R	R	R	R	R	R	R

= Unimplemented
 R = Reserved
 U = Unaffected

Figure 2-2. Control, Status, and Data Registers (Sheet 8 of 9)

Addr.	Register Name		Bit 7	6	5	4	3	2	1	Bit 0	
\$FE1B	EEPROM-2 Array Control Register (EEACR2) See page 110.	Read:	EERA	CON2	CON1	EEPRTCT	EEBP3	EEBP2	EEBP1	EEBP0	
		Write:									
		Reset:	EENV2								
\$FE1C	EEPROM-1 Non-volatile Register (EENV1) See page 98.	Read:	EERA	CON2	CON1	EEPRTCT	EEBP3	EEBP2	EEBP1	EEBP0	
		Write:									
		Reset:	Programmed value or 1 in the erased state								
\$FE1D	EEPROM-1 Control Register (EECR1) See page 96.	Read:	EEDCLK	0	EEOFF	EERAS1	EERAS0	EELAT	0	EPPGM	
		Write:									
		Reset:	0	0	0	0	0	0	0	0	0
\$FE1E	Reserved		R	R	R	R	R	R	R	R	
\$FE1F	EEPROM-1 Array Control Register (EEACR1) See page 98.	Read:	EERA	CON2	CON1	EEPRTCT	EEBP3	EEBP2	EEBP1	EEBP0	
		Write:									
		Reset:	EENV1								
\$FF80	FLASH-1 Block Protect Register (FLBPR1) See page 72.	Read:	0	0	0	0	BPR3	BPR2	BPR1	BPR0	
		Write:									
		Reset:	0	0	0	0	0	0	0	0	0
\$FF81	FLASH-2 Block Protect Register (FLBPR2) See page 73.	Read:	0	0	0	0	BPR3	BPR2	BPR1	BPR0	
		Write:									
		Reset:	0	0	0	0	0	0	0	0	0
\$FFFF	COP Control Register (COPCTL) See page 207.	Read:	Low byte of reset vector								
		Write:	Clear COP counter								
		Reset:	Unaffected by reset								

= Unimplemented
 R = Reserved
 U = Unaffected

Figure 2-2. Control, Status, and Data Registers (Sheet 9 of 9)

Table 2-1. Vector Addresses

Address	Vector
\$FFDA	TIM vector (high)
\$FFDB	TIM vector (low)
\$FFDC	BDLC vector (high)
\$FFDD	BDLC vector (low)
\$FFDE	ADC vector (high)
\$FFDF	ADC vector (low)
\$FFE0	SCI transmit vector (high)
\$FFE1	SCI transmit vector (low)
\$FFE2	SCI receive vector (high)
\$FFE3	SCI receive vector (low)
\$FFE4	SCI error vector (high)
\$FFE5	SCI error vector (low)
\$FFE6	SPI transmit vector (high)
\$FFE7	SPI transmit vector (low)
\$FFE8	SPI receive vector (high)
\$FFE9	SPI receive vector (low)
\$FFEA	TIM A overflow vector (high)
\$FFEB	TIM A overflow vector (low)
\$FFEC	TIM A channel 5 vector (high)
\$FFED	TIM A channel 5 vector (low)
\$FFEE	TIM A channel 4 vector (high)
\$FFEF	TIM A channel 4 vector (low)
\$FFF0	TIM A channel 3 vector (high)
\$FFF1	TIM A channel 3 vector (low)
\$FFF2	TIM A channel 2 vector (high)
\$FFF3	TIM A channel 2 vector (low)
\$FFF4	TIM A channel 1 vector (high)
\$FFF5	TIM A channel 1 vector (low)
\$FFF6	TIM A channel 0 vector (high)
\$FFF7	TIM A channel 0 vector (low)
\$FFF8	PLL vector (high)
\$FFF9	PLL vector (low)
\$FFFA	IRQ1 vector (high)
\$FFFB	IRQ1 vector (low)
\$FFFC	SWI vector (high)
\$FFFD	SWI vector (low)
\$FFFE	Reset vector (high)
\$FFFF	Reset vector (low)

↑ Low
 Priority
 ↓ High

Section 3. Random-Access Memory (RAM)

3.1 Contents

3.2	Introduction	61
3.3	Functional Description	61

3.2 Introduction

This section describes the 2048 bytes of random-access memory (RAM).

3.3 Functional Description

Addresses \$0050–\$044F and \$0A00–\$0DFF are the RAM locations. The location of the stack RAM is programmable with the reset stack pointer instruction (RSP). The 16-bit stack pointer allows the stack RAM to be anywhere in the 64-Kbyte memory space.

NOTE: *For correct operation, the stack pointer must point only to RAM locations.*

Within page zero are 176 bytes of RAM. Because the location of the stack RAM is programmable, all page zero RAM locations can be used for input/output (I/O) control and user data or code. When the stack pointer is moved from its reset location at \$00FF, direct addressing mode instructions can access all page zero RAM locations efficiently. Page zero RAM, therefore, provides ideal locations for frequently accessed global variables.

Random-Access Memory (RAM)

Before processing an interrupt, the central processor unit (CPU) uses five bytes of the stack to save the contents of the CPU registers.

NOTE: *For M6805, M146805, and M68HC05 compatibility, the H register is not stacked.*

During a subroutine call, the CPU uses two bytes of the stack to store the return address. The stack pointer decrements during pushes and increments during pulls.

NOTE: *Be careful when using nested subroutines. The CPU could overwrite data in the RAM during a subroutine or during the interrupt stacking operation.*

Section 4. FLASH-1 Memory

4.1 Contents

4.2	Introduction	63
4.3	Functional Description	64
4.4	FLASH-1 Control Register	65
4.5	FLASH Charge Pump Frequency Control	67
4.6	FLASH Erase Operation	67
4.7	FLASH Program/Margin Read Operation	68
4.8	FLASH Block Protection	70
4.8.1	FLASH-1 Block Protect Register	72
4.8.2	FLASH-2 Block Protect Register	73
4.9	Low-Power Modes	75
4.9.1	Wait Mode	75
4.9.2	Stop Mode	75

4.2 Introduction

This section describes the operation of the embedded FLASH-1 memory. This memory can be read, programmed, and erased from a single external supply. The program and erase operations are enabled through the use of an internal charge pump.

4.3 Functional Description

The FLASH memory physically consists of two independent arrays of 32 Kbytes with an additional 38 bytes of user vectors and two bytes of block protection. An erased bit reads as a logic 0 and a programmed bit reads as a logic 1. Program and erase operations are facilitated through control bits in a memory mapped register. Details for these operations appear later in this section. Memory in the FLASH array is organized into pages within rows. There are eight pages of memory per row with eight bytes per page. The minimum erase block size is a single row, 64 bytes. Programming is performed on a per-page basis, eight bytes at a time.

The FLASH-1 address ranges for the user memory, control register, and vectors are:

- \$8000–\$FDFF
- \$FF80–\$FF81, block protect registers
- \$FE0B, FLASH control register
- \$FFDA–\$FFFF, reserved for user-defined interrupt and reset vectors

When programming the FLASH, just enough program time must be used to program a page. Too much program time can result in a program disturb condition, in which case an erased bit on the row being programmed becomes unintentionally programmed. Program disturb is avoided by using an iterative program and margin read technique known as the smart programming algorithm. The smart programming algorithm is required whenever programming the FLASH (see [4.7 FLASH Program/Margin Read Operation](#)).

To avoid the program disturb issue, each page on the row should be programmed only once before it is erased. The eight program cycle maximum per row aligns with the architecture's eight pages of storage per row. The margin read step of the smart programming algorithm is used to ensure programmed bits are programmed to sufficient margin for data retention over the device lifetime.

The row architecture for this array is:

- \$8000–\$803F (Row 0)
- \$8040–\$807F (Row 1)
- \$8080–\$80BF (Row 2)
- -----
- \$FFC0–\$FFFF (Row 511)

Programming tools are available from Motorola. Contact a local Motorola representative for more information.

NOTE: A security feature prevents viewing of the FLASH contents.⁽¹⁾

4.4 FLASH-1 Control Register

The FLASH-1 control register (FLCR1) controls FLASH-1 program, erase, and margin read operations.

Address: \$FE0B

	Bit 7	6	5	4	3	2	1	Bit 0
Read:	FDIV1	FDIV0	BLK1	BLK0	HVEN	MARGIN	ERASE	PGM
Write:								
Reset:	0	0	0	0	0	0	0	0

Figure 4-1. FLASH-1 Control Register (FLCR1)

FDIV1 — Frequency Divide Control Bit

This read/write bit together with FDIV0 selects the factor by which the charge pump clock is divided from the system clock. See [4.5 FLASH Charge Pump Frequency Control](#).

FDIV0 — Frequency Divide Control Bit

This read/write bit together with FDIV1 selects the factor by which the charge pump clock is divided from the system clock. See [4.5 FLASH Charge Pump Frequency Control](#).

1. No security feature is absolutely secure. However, Motorola’s strategy is to make reading or copying the FLASH difficult for unauthorized users.

BLK1— Block Erase Control Bit

This read/write bit together with BLK0 allows erasing of blocks of varying size. See [4.6 FLASH Erase Operation](#) for a description of available block sizes.

BLK0 — Block Erase Control Bit

This read/write bit together with BLK1 allows erasing of blocks of varying size. See [4.6 FLASH Erase Operation](#) for a description of available block sizes.

HVEN — High-Voltage Enable Bit

This read/write bit enables the charge pump to drive high voltages for program and erase operations in the array. HVEN can be set only if either PGM = 1 or ERASE = 1 and the proper sequence for program/margin read or erase is followed.

- 1 = High voltage enabled to array and charge pump on
- 0 = High voltage disabled to array and charge pump off

MARGIN — Margin Read Control Bit

This read/write bit configures the memory for margin read operation. MARGIN cannot be set if the HVEN = 1. MARGIN will automatically return to unset (0) if asserted when HVEN = 1.

- 1 = Margin read operation selected
- 0 = Margin read operation unselected

ERASE — Erase Control Bit

This read/write bit configures the memory for erase operation. ERASE is interlocked with the PGM bit such that both bits cannot be set at the same time.

- 1 = Erase operation selected
- 0 = Erase operation unselected

PGM — Program Control Bit

This read/write bit configures the memory for program operation. PGM is interlocked with the ERASE bit such that both bits cannot be set at the same time.

- 1 = Program operation selected
- 0 = Program operation unselected

4.5 FLASH Charge Pump Frequency Control

The internal charge pump, required for program, margin read, and erase operations, is designed to operate most efficiently with a 2-MHz clock. The charge pump clock is derived from the bus clock. [Table 4-1](#) shows how the FDIV bits are used to select a charge pump frequency based on the bus clock frequency. Program, margin read, and erase operations cannot be performed if the bus clock frequency is below 2 MHz.

Table 4-1. Charge Pump Clock Frequency

FDIV1	FDIV0	Pump Clock Frequency	Bus Clock Frequency
0	0	Bus frequency ÷ 1	1.8–2.5 MHz
0	1	Bus frequency ÷ 2	3.6–5.0 MHz
1	0	Bus frequency ÷ 2	3.6–5.0 MHz
1	1	Bus frequency ÷ 4	7.2–8.4 MHz

4.6 FLASH Erase Operation

See [24.13 Memory Characteristics](#) for a detailed description of the times used in this algorithm. Use this step-by-step procedure to erase a block of FLASH memory:

1. Set the ERASE, BLK0, BLK1, FDIV0, and FDIV1 bits in the FLASH-1 control register. See [Table 4-2](#) for block sizes and [Table 4-1](#) for FDIV settings.
2. Ensure target portion of array is unprotected by reading the block protect register, FLBPR1: address \$FF80. See [4.8 FLASH Block Protection](#) and [4.8.1 FLASH-1 Block Protect Register](#) for more information.
3. Write to any FLASH address with any data within the block address range desired.
4. Set the HVEN bit.
5. Wait for a time, t_{Erase} .
6. Clear the HVEN bit.

7. Wait for a time, t_{kill} , for the high voltages to dissipate.
8. Clear the ERASE bit.
9. After time t_{HVD} , the memory can be accessed in read mode again.

NOTE: While these operations must be performed in the order shown, other unrelated operations may occur between the steps.

Table 4-2 shows the various block sizes which can be erased in one erase operation.

Table 4-2. Erase Block Sizes

BLK1	BLK0	Block Size, Addresses Cared
0	0	Full array: 30 Kbytes
0	1	One-half array: 16 Kbytes (A14)
1	0	Eight rows: 512 bytes (A14–A9)
1	1	Single row: 64 bytes (A14–A6)

In step 2 of the erase operation, the cared addresses are latched and used to determine the location of the block to be erased. For instance, with $BLK0 = BLK1 = 0$, writing to any FLASH address in the range \$8000–\$FFFF will enable the full-array erase.

NOTE: To ensure the timing requirements of the high-voltage erase and program mode of the FLASH memory, interrupts must be masked (interrupt mask bit of $CCR = 1$) when the $HVEN$ bit is set.

4.7 FLASH Program/Margin Read Operation

NOTE: After a total of eight program operations have been applied to a row, the row must be erased before further programming to avoid program disturb. An erased byte will read \$00.

Programming of the FLASH memory is done on a page basis. A page consists of eight consecutive bytes starting from address \$XXX0 or \$XXX8. The purpose of the margin read mode is to ensure that data has been programmed with sufficient margin for long-term data retention. While performing a margin read, the operation is the same as for

ordinary read mode except that a built-in counter stretches the data access for an additional eight cycles to allow sensing of the lower cell current. Margin read mode imposes a more stringent read condition on the bitcell to ensure the bitcell is programmed with enough margin for long-term data retention. During these eight cycles, the COP counter continues to run. The user must account for these extra cycles within COP feed loops. A margin read cycle can only follow a page programming operation.

To program and margin read the FLASH memory, use this step-by-step algorithm. See [24.13 Memory Characteristics](#) for a detailed description of the times used in this algorithm.

1. Set the PGM bit. This configures the memory for program operation and enables the latching of address and data for programming.
2. Read from the block protect register (FLBPR1).
3. Write data to the eight bytes of the page being programmed. This requires eight separate write operations.
4. Set the HVEN bit.
5. Wait for a time, t_{PROG} .
6. Clear the HVEN bit.
7. Wait for a time, t_{HVTV} .
8. Set the MARGIN bit.
9. Wait for a time, t_{VTP} .
10. Clear the PGM bit.
11. Wait for a time, t_{HVD} .
12. Read back data in margin read mode. This is done in eight separate read operations which are each stretched by eight cycles.
13. Clear the MARGIN bit.

NOTE: *While these operations must be performed in the order shown, other unrelated operations may occur between the steps.*

This program/margin read sequence is repeated throughout the memory until all data is programmed. The smart programming algorithm shown in [Figure 4-2](#) is always required when programming any part of the array. This algorithm ensures the minimum possible program time and avoids the deleterious program disturb effect. (See [4.6 FLASH Erase Operation](#).)

NOTE: *In order to ensure the timing requirements of the high-voltage erase and program mode of the FLASH memory, interrupts must be masked (interrupt mask bit of CCR = 1) when the HVEN bit is set.*

4.8 FLASH Block Protection

NOTE: *In performing a program or erase operation, the FLASH block protect register must be read after setting the PGM or ERASE bit and before asserting the HVEN bit.*

Due to the ability of the on-board charge pump to erase and program the FLASH memory in the target application, provision is made for protecting blocks of memory from unintentional erase or program operations due to system malfunction. This protection is done by reserving a location in the memory for block protect information and requiring that this location be read from to enable setting of the HVEN bit. When the block protect register is read, its contents are latched by the FLASH control logic. If the address range for an erase or program operation includes a protected block, the PGM or ERASE bit is cleared which prevents the HVEN bit in the FLASH control register from being set so that no high voltage is allowed in the array.

When the block protect register is erased (all 0s), the entire memory is accessible for program and erase. When bits within the register are programmed, they lock blocks of memory address ranges as shown in [4.8.1 FLASH-1 Block Protect Register](#). The block protect register itself can be erased or programmed only with an external voltage V_{HI} present on the \overline{IRQ} pin. The presence of V_{HI} on the \overline{IRQ} pin also allows entry into monitor mode out of reset. Therefore, the ability to change the block protect register is voltage dependent and can occur in either user or monitor modes.

Page Program/Margin Read Procedure

Note: This algorithm is mandatory for programming the FLASH 2TS.

Note: This page program algorithm assumes the page/s to be programmed are initially erased.

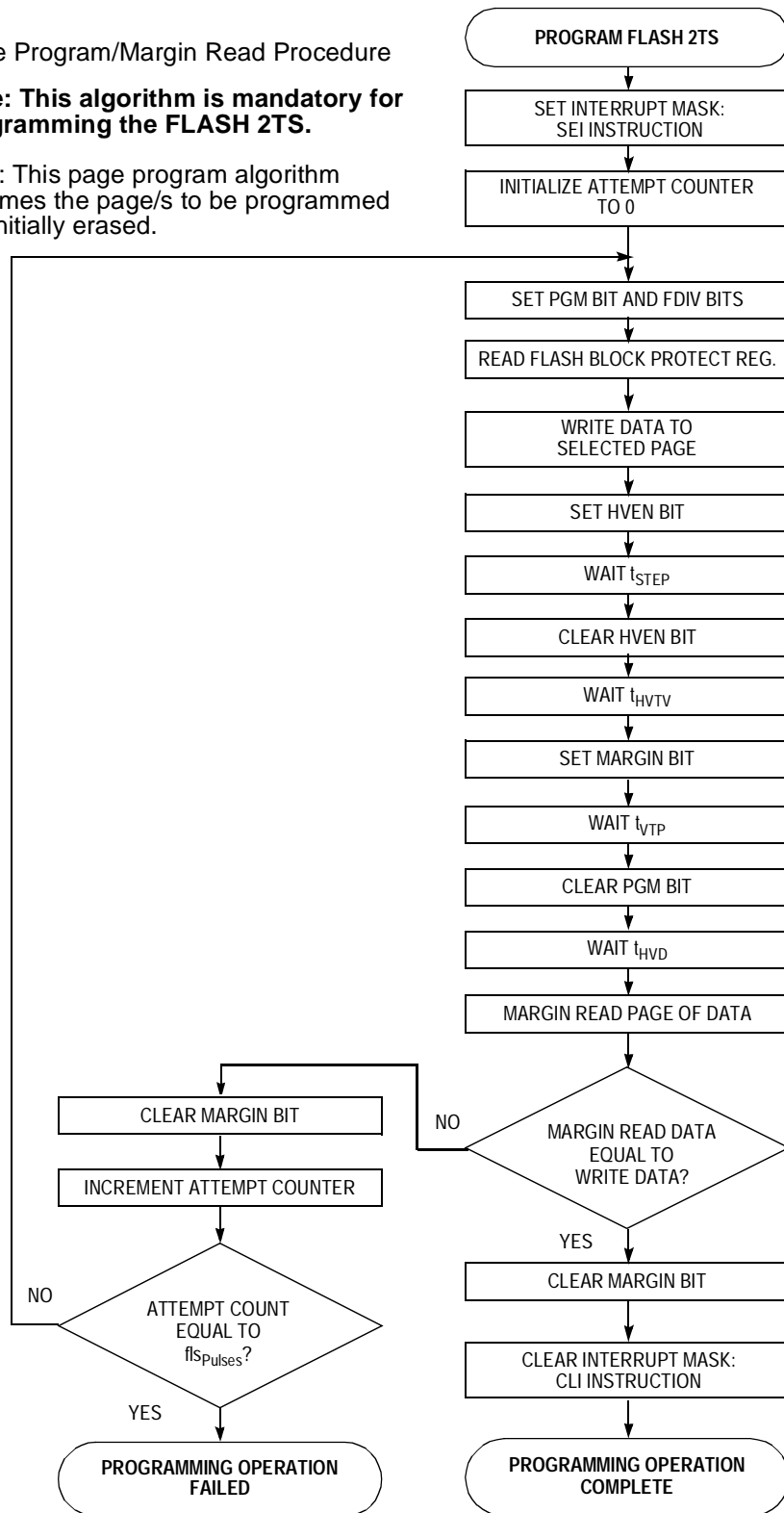

Figure 4-2. Smart Programming Algorithm

4.8.1 FLASH-1 Block Protect Register

The block protect register (FLBPR1) is implemented as a byte within the FLASH-1 memory. Each bit, when programmed, protects a range of addresses in the FLASH-1 array.

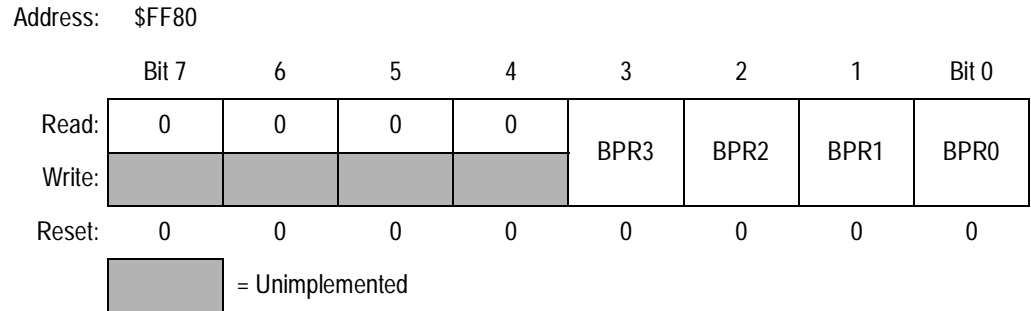

Figure 4-3. FLASH-1 Block Protect Register (FLBPR1)

BPR3 — Block Protect Register Bit 3

This bit protects the FLASH memory contents in the address range \$C000–\$FFFF.

- 1 = Address range protected from erase or program
- 0 = Address range open to erase or program

BPR2 — Block Protect Register Bit 2

This bit protects the FLASH memory contents in the address range \$A000–\$FFFF.

- 1 = Address range protected from erase or program
- 0 = Address range open to erase or program

BPR1 — Block Protect Register Bit 1

This bit protects the FLASH memory contents in the address range \$9000–\$FFFF.

- 1 = Address range protected from erase or program
- 0 = Address range open to erase or program

BPR0 — Block Protect Register Bit 0

This bit protects the FLASH memory contents in the address range \$8000–\$FFFF.

- 1 = Address range protected from erase or program
- 0 = Address range open to erase or program

By programming the block protect bits, a portion of the memory will be locked so that no further erase or program operations may be performed. Programming more than one bit at a time is redundant. If both bit 1 and bit 2 are set, for instance, the address range \$9000–\$FFFF is locked. If all bits are erased, then all of the memory is available for erase and program. The presence of a voltage V_{HI} on the \overline{IRQ} pin will bypass the block protection so that all of the memory, including the block protect register, is open for program and erase operations.

4.8.2 FLASH-2 Block Protect Register

NOTE: *This block protect register controls the FLASH-2 array block protection. However, since it is physically located in the FLASH-1 array, the FLASH-1 control register must be used to program/erase this register.*

The block protect register (FLBPR2) is implemented as a byte within the FLASH-1 memory. Each bit, when programmed, protects a range of addresses in the FLASH-2 array.

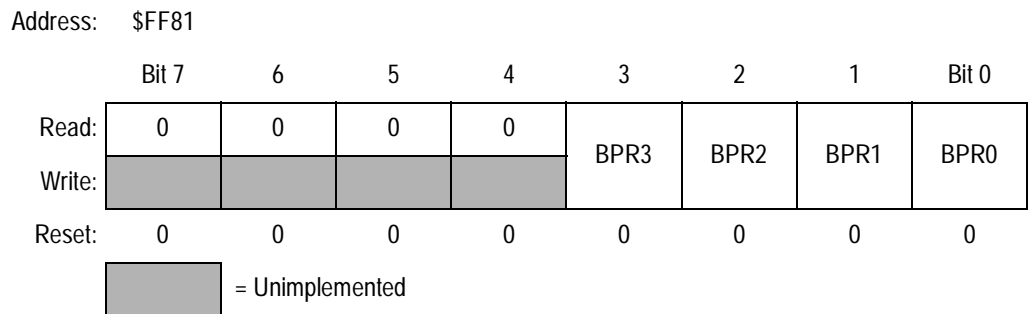

Figure 4-4. FLASH-2 Block Protect Register (FLBPR2)

BPR3 — Block Protect Register Bit 3

This bit protects the FLASH memory contents in the address range \$4000–\$7FFF.

- 1 = Address range protected from erase or program
- 0 = Address range open to erase or program

BPR2 — Block Protect Register Bit 2

This bit protects the FLASH memory contents in the address range \$2000–\$7FFF.

1 = Address range protected from erase or program

0 = Address range open to erase or program

BPR1 — Block Protect Register Bit 1

This bit protects the FLASH memory contents in the address range \$1000–\$7FFF.

1 = Address range protected from erase or program

0 = Address range open to erase or program

BPR0 — Block Protect Register Bit 0

This bit protects the FLASH memory contents in the address range \$0450–\$7FFF.

1 = Address range protected from erase or program

0 = Address range open to erase or program

By programming the block protect bits, a portion of the memory will be locked so that no further erase or program operations may be performed. Programming more than one bit at a time is redundant. If both bit 1 and bit 2 are set, for instance, the address range \$1000–\$FFFF is locked. If all bits are erased, then all of the memory is available for erase and program. The presence of a voltage V_{HI} on the \overline{IRQ} pin will bypass the block protection so that all of the memory, including the block protect register, is open for program and erase operations.

4.9 Low-Power Modes

The WAIT and STOP instructions put the MCU in low power-consumption standby modes.

4.9.1 Wait Mode

Putting the MCU into wait mode while the FLASH is in read mode does not affect the operation of the FLASH memory directly, but there will be no memory activity since the CPU is inactive.

The WAIT instruction should not be executed while performing a program or erase operation on the FLASH. When the MCU is put into wait mode, the charge pump for the FLASH is disabled so that neither a program nor erase operation will continue. If the memory is in either program mode (PGM = 1, HVEN = 1) or erase mode (ERASE = 1, HVEN = 1), then it will remain in that mode during wait. Exit from wait must now be done with a reset rather than an interrupt because if exiting wait with an interrupt, the memory will not be in read mode and the interrupt vector cannot be read from the memory.

4.9.2 Stop Mode

When the MCU is put into stop mode, if the FLASH is in read mode, it will be put into low-power standby.

The STOP instruction should not be executed while performing a program or erase operation on the FLASH. When the MCU is put into stop mode, the charge pump for the FLASH is disabled so that neither a program nor erase operation will continue. If the memory is in either program mode (PGM = 1, HVEN = 1) or erase mode (ERASE = 1, HVEN = 1), then it will remain in that mode during stop. Exit from stop must now be done with a reset rather than an interrupt because if exiting stop with an interrupt, the memory will not be in read mode and the interrupt vector cannot be read from the memory.

Section 5. FLASH-2 Memory

5.1 Contents

5.2	Introduction	77
5.3	Functional Description	78
5.4	FLASH Control Register	79
5.5	FLASH Charge Pump Frequency Control	81
5.6	FLASH Erase Operation	81
5.7	FLASH Program/Margin Read Operation	82
5.8	FLASH Block Protection	84
5.9	FLASH Block Protect Register	86
5.10	Low-Power Modes	86
5.10.1	Wait Mode	86
5.10.2	Stop Mode	86

5.2 Introduction

This section describes the operation of the embedded FLASH-2 memory. This memory can be read, programmed, and erased from a single external supply. The program and erase operations are enabled through the use of an internal charge pump.

5.3 Functional Description

The FLASH-2 memory is an array of up to 29,616 bytes. An erased bit reads as a logic 0 and a programmed bit reads as a logic 1. Program and erase operations are facilitated through control bits in a memory mapped register. Details for these operations appear later in this section. Memory in the FLASH array is organized into pages within rows. There are eight pages of memory per row with eight bytes per page. The minimum erase block size is a single row, 64 bytes. Programming is performed on a per-page basis, eight bytes at a time.

The address ranges for the user memory and the control register are:

- \$0450–\$05FF
- \$0E00–\$7FFF
- \$FE11, FLASH-2 control register

When programming the FLASH, just enough program time must be used to program a page. Too much program time can result in a program disturb condition, in which case an erased bit on the row being programmed becomes unintentionally programmed. Program disturb is avoided by using an iterative program and margin read technique known as the smart programming algorithm. The smart programming algorithm is required whenever programming the FLASH. See [5.7 FLASH Program/Margin Read Operation](#).

To avoid the program disturb issue, each storage page of the row should not be programmed more than once before it is erased. The eight program cycle maximum per row aligns with the architecture's eight pages of storage per row. The margin read step of the smart programming algorithm is used to ensure programmed bits are programmed to sufficient margin for data retention over the device lifetime.

The row architecture for this array is:

- \$7F40–\$7F7F (Row 509)
- \$7F80–\$7FBF (Row 510)
- \$7FC0–\$7FFF (Row 511)

Programming tools are available from Motorola. Contact a local Motorola representative for more information.

NOTE: A security feature prevents viewing of the FLASH contents.⁽¹⁾

5.4 FLASH Control Register

The FLASH-2 control register (FLCR2) controls FLASH-2 program, erase, and margin read operations.

Address: \$FE11

	Bit 7	6	5	4	3	2	1	Bit 0
Read:	FDIV1	FDIV0	BLK1	BLK0	HVEN	MARGIN	ERASE	PGM
Write:								
Reset:	0	0	0	0	0	0	0	0

Figure 5-1. FLASH-2 Control Register (FLCR2)

FDIV1 — Frequency Divide Control Bit

This read/write bit together with FDIV0 selects the factor by which the charge pump clock is divided from the system clock. See [5.5 FLASH Charge Pump Frequency Control](#).

FDIV0 — Frequency Divide Control Bit

This read/write bit together with FDIV1 selects the factor by which the charge pump clock is divided from the system clock. See [5.5 FLASH Charge Pump Frequency Control](#).

BLK1 — Block Erase Control Bit

This read/write bit together with BLK0 allows erasing of blocks of varying size. See [5.6 FLASH Erase Operation](#) for a description of available block sizes.

1. No security feature is absolutely secure. However, Motorola's strategy is to make reading or copying the FLASH difficult for unauthorized users.

BLK0 — Block Erase Control Bit

This read/write bit together with BLK1 allows erasing of blocks of varying size. See [5.6 FLASH Erase Operation](#) for a description of available block sizes.

HVEN — High-Voltage Enable Bit

This read/write bit enables the charge pump to drive high voltages for program and erase operations in the array. HVEN can be set only if either PGM = 1 or ERASE = 1 and the proper sequence for program/margin read or erase is followed.

- 1 = High voltage enabled to array and charge pump on
- 0 = High voltage disabled to array and charge pump off

MARGIN — Margin Read Control Bit

This read/write bit configures the memory for margin read operation. MARGIN cannot be set if the HVEN = 1. MARGIN will automatically return to unset (0) if asserted when HVEN = 1.

- 1 = Margin read operation selected
- 0 = Margin read operation unselected

ERASE — Erase Control Bit

This read/write bit configures the memory for erase operation. ERASE is interlocked with the PGM bit such that both bits cannot be set at the same time.

- 1 = Erase operation selected
- 0 = Erase operation unselected

PGM — Program Control Bit

This read/write bit configures the memory for program operation. PGM is interlocked with the ERASE bit such that both bits cannot be set at the same time.

- 1 = Program operation selected
- 0 = Program operation unselected

5.5 FLASH Charge Pump Frequency Control

The internal charge pump, required for program, margin read, and erase operations, is designed to operate most efficiently with a 2-MHz clock. The charge pump clock is derived from the bus clock. [Table 5-1](#) shows how the FDIV bits are used to select a charge pump frequency based on the bus clock frequency. Program, margin read, and erase operations cannot be performed if the bus clock frequency is below 2 MHz.

Table 5-1. Charge Pump Clock Frequency

FDIV1	FDIV0	Pump Clock Frequency	Bus Clock Frequency
0	0	Bus frequency \div 1	1.8–2.5 MHz
0	1	Bus frequency \div 2	3.6–5.0 MHz
1	0	Bus frequency \div 2	3.6–5.0 MHz
1	1	Bus frequency \div 4	7.2–8.4 MHz

5.6 FLASH Erase Operation

See [24.13 Memory Characteristics](#) for a detailed description of the times used in this algorithm. Use this step-by-step procedure to erase a block of FLASH-2 memory:

1. Set the ERASE, BLK0, BLK1, FDIV0, and FDIV1 bits in the FLASH control register. See [Table 5-2](#) for block sizes and [Table 5-1](#) for FDIV settings.
2. Ensure target portion of array is unprotected by reading the block protect register: address \$FF81. See [5.8 FLASH Block Protection](#) and [5.9 FLASH Block Protect Register](#) for more information.
3. Write to any FLASH address with any data within the block address range desired.
4. Set the HVEN bit.
5. Wait for a time, t_{Erase} .
6. Clear the HVEN bit.

7. Wait for a time, t_{kill} , for the high voltages to dissipate.
8. Clear the ERASE bit.
9. After a time, t_{HVD} , the memory can be accessed in read mode again.

NOTE: While these operations must be performed in the order shown, other unrelated operations may occur between the steps.

Table 5-2 shows the various block sizes which can be erased in one erase operation.

Table 5-2. Erase Block Sizes

BLK1	BLK0	Block Size, Addresses Cared
0	0	Full array: 24 Kbytes
0	1	One-half array: 16 Kbytes (A14)
1	0	Eight rows: 512 bytes (A14–A9)
1	1	Single row: 64 bytes (A14–A6)

In step 2 of the erase operation, the cared addresses are latched and used to determine the location of the block to be erased. For instance, with BLK0 = BLK1 = 0, writing to any FLASH address in the range \$0450–\$05FF or \$0E00–\$7FFF will enable the full-array erase.

NOTE: To ensure the timing requirements of the high-voltage erase and program mode of the FLASH memory, interrupts must be masked (interrupt mask bit of CCR = 1) when the HVEN bit is set.

5.7 FLASH Program/Margin Read Operation

NOTE: After a total of eight program operations have been applied to a row, the row must be erased before further programming to avoid program disturb. An erased byte will read \$00.

Programming of the FLASH memory is done on a page basis. A page consists of eight consecutive bytes starting from address \$XXX0 or \$XXX8. The purpose of the margin read, mode is to ensure that data has been programmed with sufficient margin for long-term data retention.

While performing a margin read, the operation is the same as for ordinary read mode except that a built-in counter stretches the data access for an additional eight cycles to allow sensing of the lower cell current. Margin read mode imposes a more stringent read condition on the bitcell to ensure the bitcell is programmed with enough margin for long-term data retention. During these eight cycles, the computer operating properly (COP) counter continues to run. The user must account for these extra cycles within COP feed loops. A margin read cycle can only follow a page programming operation.

To program and margin read the FLASH memory, use this step-by-step algorithm. See [24.13 Memory Characteristics](#) for a detailed description of the times used in this algorithm.

1. Set the PGM bit. This configures the memory for program operation and enables the latching of address and data for programming.
2. Read from the block protect register (FLBPR2).
3. Write data to the eight bytes of the page being programmed. This requires eight separate write operations.
4. Set the HVEN bit.
5. Wait for a time, t_{PROG} .
6. Clear the HVEN bit.
7. Wait for a time, t_{HVTV} .
8. Set the MARGIN bit.
9. Wait for a time, t_{VTP} .
10. Clear the PGM bit.
11. Wait for a time, t_{HVD} .
12. Read back data in margin read mode. This is done in eight separate read operations which are each stretched by eight cycles.
13. Clear the MARGIN bit.

NOTE: *While these operations must be performed in the order shown, other unrelated operations may occur between the steps.*

This program/margin read sequence is repeated throughout the memory until all data is programmed. The smart programming algorithm shown in [Figure 5-2](#) is always required when programming any part of the array. This algorithm ensures the minimum possible program time and avoids the deleterious program disturb effect. See [5.6 FLASH Erase Operation](#).

NOTE: *To ensure the timing requirements of the high-voltage erase and program mode of the FLASH memory, interrupts must be masked (interrupt mask bit of CCR = 1) when the HVEN bit is set.*

5.8 FLASH Block Protection

NOTE: *In performing a program or erase operation, the FLASH block protect register must be read after setting the PGM or ERASE bit and before asserting the HVEN bit.*

Due to the ability of the on-board charge pump to erase and program the FLASH memory in the target application, provision is made for protecting blocks of memory from unintentional erase or program operations due to system malfunction. This protection is done by reserving a location in the memory for block protect information and requiring that this location be read before setting the HVEN bit. When the block protect register is read, its contents are latched by the FLASH control logic. If the address range for an erase or program operation includes a protected block, the PGM or ERASE bit is cleared which prevents the HVEN bit in the FLASH control register from being set so that no high voltage is allowed in the array.

When the block protect register is erased (all 0s), the entire memory is accessible for program and erase. When bits within the register are programmed, they lock blocks of memory address ranges as shown in [5.9 FLASH Block Protect Register](#). The block protect register itself can be erased or programmed only with an external voltage V_{HI} present on the \overline{IRQ} pin. The presence of V_{HI} on the \overline{IRQ} pin also allows entry into monitor mode out of reset. Therefore, the ability to change the block protect register is voltage dependent and can occur in either user or monitor modes.

Page Program/Margin Read Procedure

Note: This algorithm is mandatory for programming the FLASH 2TS.

Note: This page program algorithm assumes the page/s to be programmed are initially erased.

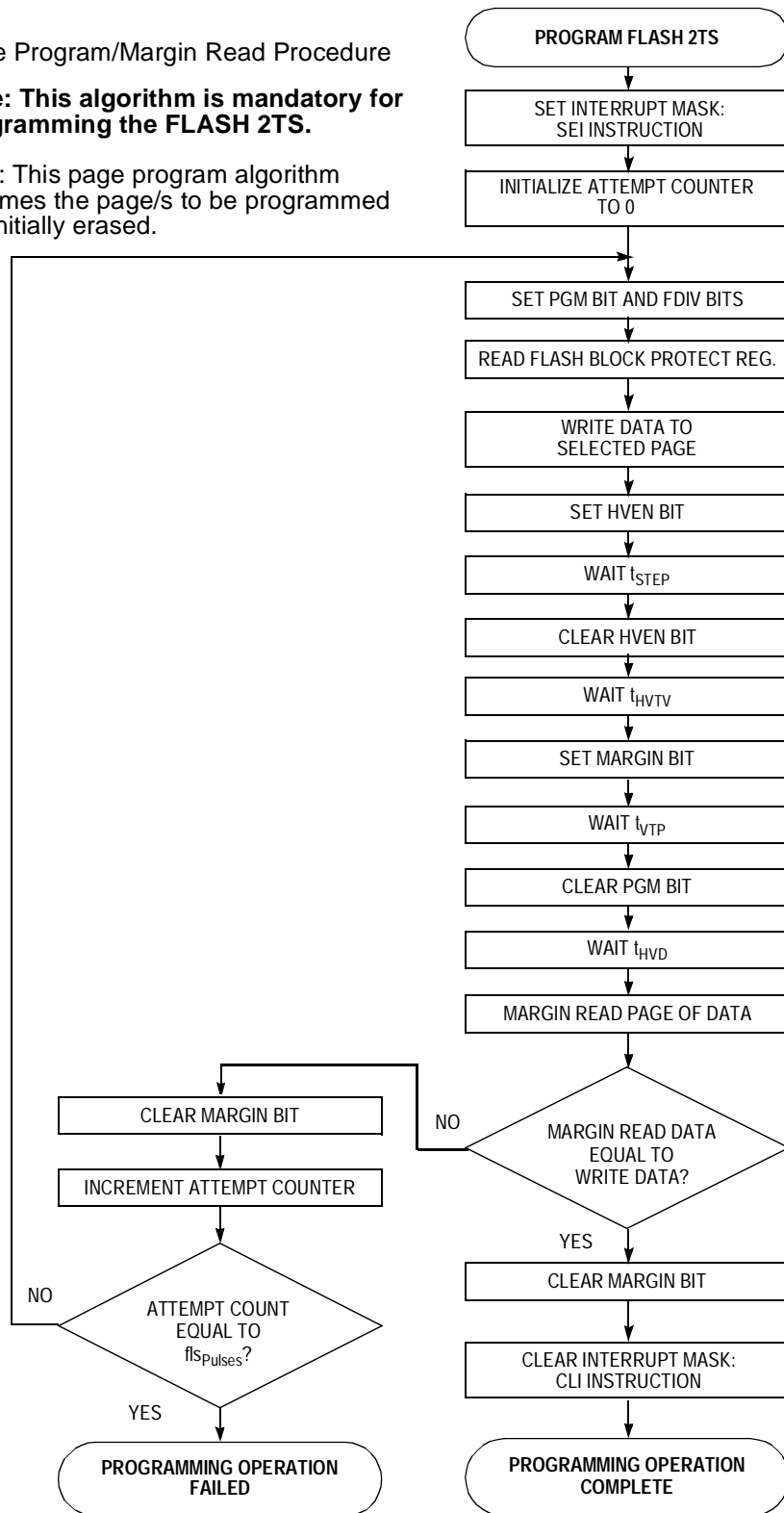

Figure 5-2. Smart Programming Algorithm

5.9 FLASH Block Protect Register

The block protect register for FLASH-2 is physically implemented as a byte within the FLASH-1 memory. Refer to [Figure 4-4. FLASH-2 Block Protect Register \(FLBPR2\)](#) for definition of this register. Each bit, when programmed, protects a range of addresses in the FLASH-2 array.

5.10 Low-Power Modes

The WAIT and STOP instructions put the MCU in low power-consumption standby modes.

5.10.1 Wait Mode

Putting the MCU into wait mode while the FLASH is in read mode does not affect the operation of the FLASH memory directly, but there will not be any memory activity since the CPU is inactive.

The WAIT instruction should not be executed while performing a program or erase operation on the FLASH. When the MCU is put into wait mode, the charge pump for the FLASH is disabled so that either a program or erase operation will not continue. If the memory is in either program mode (PGM = 1, HVEN = 1) or erase mode (ERASE = 1, HVEN = 1), then it will remain in that mode during wait. Exit from wait must now be done with a reset rather than an interrupt because if exiting wait with an interrupt, the memory will not be in read mode and the interrupt vector cannot be read from the memory.

5.10.2 Stop Mode

When the MCU is put into stop mode, if the FLASH is in read mode, it will be put into low-power standby.

The STOP instruction should not be executed while performing a program or erase operation on the FLASH. When the MCU is put into stop mode, the charge pump for the FLASH is disabled so that either a program or erase operation will not continue. If the memory is in either program mode (PGM = 1, HVEN = 1) or erase mode (ERASE = 1,

HVEN = 1), then it will remain in that mode during wait. Exit from stop must now be done with a reset rather than an interrupt because if exiting stop with an interrupt, the memory will not be in read mode and the interrupt vector cannot be read from the memory.

Section 6. EEPROM-1

6.1 Contents

6.2	Introduction	89
6.3	Features	90
6.4	Functional Description	90
6.4.1	EEPROM Programming	90
6.4.2	EEPROM Erasing	92
6.4.3	EEPROM Block Protection	94
6.4.4	EEPROM Redundant Mode	94
6.4.5	MCU Configuration	95
6.4.6	EEPROM Protection	95
6.4.7	EEPROM Control Register	96
6.4.8	EEPROM Non-Volatile Register and EEPROM Array Configuration Register	98
6.5	Low-Power Modes	100
6.5.1	Wait Mode	100
6.5.2	Stop Mode	100

6.2 Introduction

This section describes the electrically erasable programmable read-only memory (EEPROM). The 1024 bytes available on the MC68HC908AS60 are physically located in two 512-byte arrays. This section details the array covering the address range \$0800–\$09FF. For information relating to the array covering address range \$0600–\$07FF, see [Section 7. EEPROM-2](#).

6.3 Features

EEPROM features include:

- Byte, block, or bulk erasable
- Non-volatile redundant array option
- Non-volatile block protection option
- Non-volatile MCU configuration bits
- On-chip charge pump for programming/erasing
- Security option

6.4 Functional Description

The 512 bytes of EEPROM-1 can be programmed or erased without an external voltage supply. EEPROM cells are protected with a non-volatile block protection option. These options are stored in the EEPROM non-volatile register (EENVR1) and are loaded into the EEPROM array configuration register after reset (EEACR1) or a read of EENVR1. Hardware interlocks are provided to protect stored data corruption from accidental programming/erasing.

6.4.1 EEPROM Programming

The unprogrammed state is a logic 1. Programming changes the state to a logic 0. Only valid EEPROM bytes in the non-protected blocks and EENVR1 can be programmed. When the array is configured in the redundant mode, programming the first 256 bytes also will program the last 256 bytes with the same data. Programming the EEPROM in the non-redundant mode is recommended. Program the data to both locations before entering redundant mode.

Follow this step-by-step procedure to program a byte of EEPROM:

1. Clear EERAS1 and EERAS0 and set EELAT in the EECR1. (See notes a and b.)
2. Write the desired data to any user EEPROM address.
3. Set the EEPGM bit. (See note c.)
4. Wait for a time, t_{EEPGM} , to program the byte.
5. Clear EEPGM bit.
6. Wait for a time, t_{EEFPV} , for the programming voltage to fall.
7. Clear EELAT bits. (See note d.)
8. Repeat steps 1 to 7 for more EEPROM programming.

Notes:

- a. EERAS1 and EERAS0 must be cleared for programming. Otherwise, the part will be in erase mode.
- b. Setting EELAT bit configures the address and data buses to latch data for programming the array. Only data with valid EEPROM address will be latched. If another consecutive valid EEPROM write occurs, this address and data will override the previous address and data. Any attempts to read other EEPROM data will read the latched data. If EELAT is set, other writes to the EECR1 will be allowed only after a valid EEPROM write.
- c. To ensure proper programming sequence, the EEPGM bit cannot be set if the EELAT bit is cleared and a non-EEPROM write has occurred. When EEPGM is set, the on-board charge pump generates the program voltage and applies it to the user EEPROM array. When the EEPGM bit is cleared, the program voltage is removed from the array and the internal charge pump is turned off.
- d. Any attempt to clear both EEPGM and EELAT bits with a single instruction will only clear EEPGM. This is to allow time for removal of high voltage from the EEPROM array.

6.4.2 EEPROM Erasing

The unprogrammed state is a logic 1. Only the valid EEPROM bytes in the non-protected blocks and EENVR1 can be erased. When the array is configured in the redundant mode, erasing the first 256 bytes also will erase the last 256 bytes.

Using this step-by-step procedure erases EEPROM:

1. Clear/set EERAS1 and EERAS0 to select byte/block/bulk erase, and set EELAT in EECR1. (See note a.)
2. Write any data to the desired address for byte erase, to any address in the desired block for block erase, or to any array address for bulk erase.
3. Set the EEPGM bit. (See note b.)
4. Wait for a time, $t_{EEPGM}/t_{EEBLOCK}/t_{EEBULK}$.
5. Clear EEPGM bit.
6. Wait for a time, t_{EEFPV} , for the erasing voltage to fall.
7. Clear EELAT bits. (See note c.)
8. Repeat steps 1 to 7 for more EEPROM byte/block erasing.

EEBPx bit must be cleared to erase EEPROM data in the corresponding block. If any EEBPx is set, the corresponding block cannot be erased and bulk erase mode does not apply.

Notes:

- a. Setting EELAT bit configures the address and data buses to latch data for erasing the array. Only valid EEPROM addresses with their data will be latched. If another consecutive valid EEPROM write occurs, this address and data will override the previous address and data. In block erase mode, any EEPROM address in the block may be used in step 2. All locations within this block will be erased. In bulk erase mode, any EEPROM address may be used to erase the whole EEPROM. EENVR1 is not affected with block or bulk erase. Any attempts to read other EEPROM data will read the latched data. If EELAT is set, other writes to the EECR1 will be allowed only after a valid EEPROM write.

- b. The EEPGM bit cannot be set if the EELAT bit is cleared and a non-EEPROM write has occurred. This is to ensure proper erasing sequence. Once EEPGM is set, the type of erase mode cannot be modified. If EEPGM is set, the on-board charge pump generates the erase voltage and applies it to the user EEPROM array. When the EEPGM bit is cleared, the erase voltage is removed from the array and the internal charge pump is turned off.
- c. Any attempt to clear both EEPGM and EELAT bits with a single instruction will only clear EEPGM. This is to allow time for removal of high voltage from the EEPROM array.

In general, all bits should be erased before being programmed. However, if program/erase cycling is of concern, minimize bit cycling in each EEPROM byte. If any bit in a byte requires change from a 0 to a 1, the byte needs to be erased before programming. [Table 6-1](#) summarizes the conditions for erasing before programming

Table 6-1. EEPROM Program/Erase Cycling Reduction

EEPROM Data To Be Programmed	EEPROM Data Before Programming	Erase Before Programming?
0	0	No
0	1	No
1	0	Yes
1	1	No

6.4.3 EEPROM Block Protection

The 512 bytes of EEPROM are divided into four 128-byte blocks. Each of these blocks can be separately protected by EEBPx bit. Any attempt to program or erase memory locations within the protected block will not allow the program/erase voltage to be applied to the array. [Table 6-2](#) shows the address ranges within the blocks.

Table 6-2. EEPROM Array Address Blocks

Block Number (EEBPx)	Address Range
EEBP0	\$0800–\$087F
EEBP1	\$0880–\$08FF
EEBP2	\$0900–\$097F
EEBP3	\$0980–\$09FF

If EEBPx bit is set, that corresponding address block is protected. These bits are effective after a reset or a read to EENVR1 register. The block protect configuration can be modified by erasing/programming the corresponding bits in the EENVR1 register and then reading the EENVR1 register.

In redundant mode, EEBP3 and EEBP2 will have no meaning.

6.4.4 EEPROM Redundant Mode

To extend the EEPROM data retention, the array can be placed in redundant mode. In this mode, the first 256 bytes of user EEPROM array are mapped to the last 256 bytes. Reading, programming, and erasing of the first 256 EEPROM bytes will physically affect two bytes of EEPROM. Addressing the last 256 bytes will not be recognized. Block protection still applies but EEBP3 and EEBP2 are meaningless.

NOTE: *Programming the EEPROM in non-redundant mode and programming the data to its corresponding location before entering redundant mode is recommended.*

The EEPROM non-volatile register (EENVR1) contains configurations concerning block protection and redundancy. EENVR1 is physically located on the bottom of the EEPROM array. The contents are non-volatile and are not modified by reset. On reset, this special register loads the EEPROM configuration into a corresponding volatile EEPROM array configuration register (EEACR1). Thereafter, all reads to the EENVR1 will reload EEACR1.

The EEPROM configuration can be changed by programming/erasing the EENVR1 like a normal EEPROM byte. The new array configuration will take affect with a system reset or a read of the EENVR1.

6.4.5 MCU Configuration

The EEPROM non-volatile register (EENVR1) also contains general-purpose bits which can be used to enable/disable functions within the MCU which, for safety reasons, need to be controlled from non-volatile memory. On reset, this special register loads the MCU configuration into the volatile EEPROM array configuration register (EEACR1). Thereafter, all reads to the EENVR1 will reload EEACR1.

The MCU configuration can be changed by programming/erasing the EENVR1 like a normal EEPROM byte. Note that it is the user's responsibility to program the EENVR1 register to the correct system requirements and verify it prior to use. The new array configuration will take effect after a system reset or a read of the EENVR1.

6.4.6 EEPROM Protection

The MC68HC908AS60 has a special protection option which prevents program/erase access to memory locations \$08F0–\$08FF. This protect function is enabled by programming the EEPRTCT bit in the EENVR to 0.

In addition to the disabling of the program and erase operations on memory locations \$08F0–\$08FF, the enabling of the protect option has the following effects:

- Bulk and block erase modes are disabled.
- Programming and erasing of the EENVR are disabled.
- Unsecure locations (\$0800–\$08EF) can be erased using the single byte erase function as normal.
- Secured locations can be read as normal.
- Writing to a secure location no longer qualifies as a valid EEPROM write as detailed in [6.4.1 EEPROM Programming](#) note b and [6.4.2 EEPROM Erasing](#) note a.

NOTE: *Once armed, the protect option is permanently enabled. As a consequence, all functions in the EENVR will remain in the state they were in immediately before the security was enabled.*

6.4.7 EEPROM Control Register

This read/write register controls programming/erasing of the array.

Address: \$FE1D

	Bit 7	6	5	4	3	2	1	Bit 0
Read:	EEBCLK	0	EEOFF	EERAS1	EERAS0	EELAT	0	EEPGM
Write:								
Reset:	0	0	0	0	0	0	0	0

 = Unimplemented

Figure 6-1. EEPROM-1 Control Register (EECR1)

EEBCLK — EEPROM Bus Clock Enable Bit

This read/write bit determines which clock will be used to drive the internal charge pump for programming/erasing. Reset clears this bit.

1 = Bus clock drives charge pump.

0 = Internal RC oscillator drives charge pump.

NOTE: *It is recommended that the internal RC oscillator be used to drive the internal charge pump for applications that have a bus frequency of less than 8 MHz.*

EEOFF — EEPROM Power Down Bit

This read/write bit disables the EEPROM module for lower power consumption. Any attempts to access the array will give unpredictable results. Reset clears this bit.

1 = Disable EEPROM array

0 = Enable EEPROM array

NOTE: *The EEPROM requires a recovery time, t_{EEOFF} , to stabilize after clearing the EEOFF bit.*

EERAS1 and EERAS0 — Erase Bits

These read/write bits set the erase modes (see [Table 6-3](#)). Reset clears these bits.

Table 6-3. EEPROM Program/Erase Mode Select

EEBPx	EERAS1	EERAS0	MODE
0	0	0	Byte program
0	0	1	Byte erase
0	1	0	Block erase
0	1	1	Bulk erase
1	X	X	No erase/program

X = Don't care

EELAT — EEPROM Latch Control Bit

This read/write bit latches the address and data buses for programming the EEPROM array. EELAT cannot be cleared if EEPGM is still set. Reset clears this bit.

1 = Buses configured for EEPROM programming

0 = Buses configured for normal read operation

EEPGM — EEPROM Program/Erase Enable Bit

This read/write bit enables the internal charge pump and applies the programming/erasing voltage to the EEPROM array if the EELAT bit is set and a write to a valid EEPROM location has occurred. Reset clears the EEGPM bit.

- 1 = EEPROM programming/erasing power switched on
- 0 = EEPROM programming/erasing power switched off

NOTE: Writing logic 0s to both the EELAT and EEGPM bits with a single instruction will clear EEGPM only to allow time for the removal of high voltage.

6.4.8 EEPROM Non-Volatile Register and EEPROM Array Configuration Register

The EEPROM non-volatile register (EENVR1) and array configuration register (EEACR1) are shown in Figure 6-2 and Figure 6-3.

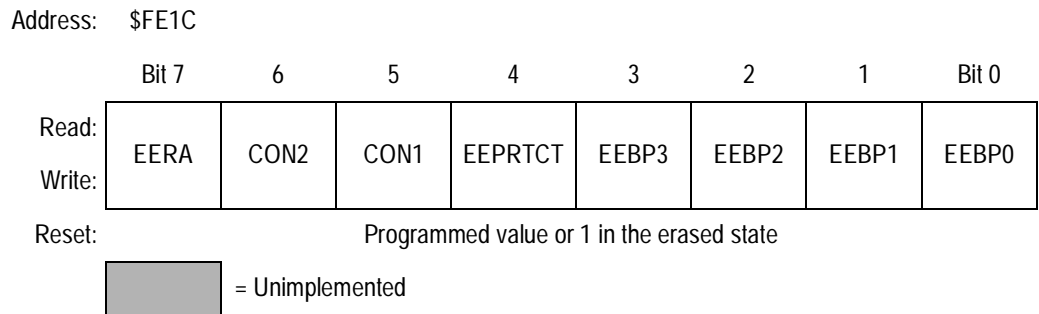

Figure 6-2. EEPROM-1 Non-Volatile Register (EENVR1)

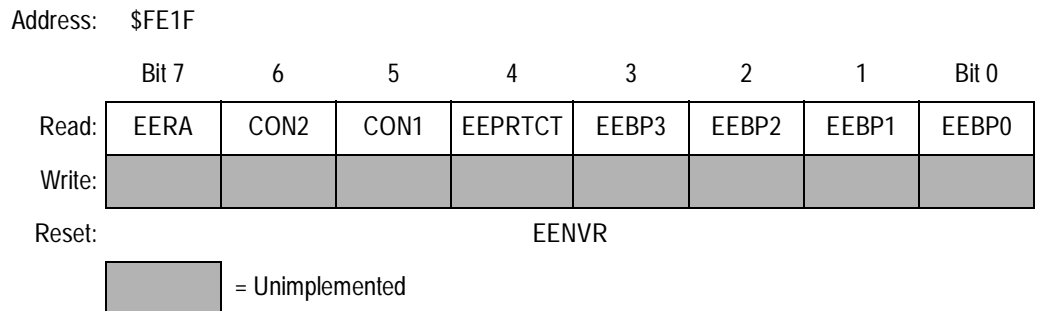

Figure 6-3. EEPROM-1 Array Control Register (EEACR1)

EERA — EEPROM Redundant Array Bit

This programmable/erasable/read bit in EENVR1 and read-only bit in EEACR1 configures the array in redundant mode. Reset loads EERA from EENVR1 to EEACR1.

1 = EEPROM array is in redundant mode configuration.

0 = EEPROM array is in normal mode configuration.

CON2 and CON1 — MCU Configuration Bits

These read/write bits can be used to enable/disable functions within the MCU. Reset loads CONx from EENVR1 to EEACR1.

NOTE: *The EEPROM protection feature is a write-once feature. Once the protection is enabled, it may not be disabled.*

EEPRTCT — EEPROM Protection Bit

This one-time programmable bit can be used to protect 16 bytes (\$8F0–\$8FF) from being erased or programmed.

1 = EEPROM protection disabled

0 = EEPROM protection enabled

EEBP3–EEBP0 — EEPROM Block Protection Bits

These read/write bits select blocks of EEPROM array from being programmed or erased. Reset loads EEBP3–EEBP0 from EENVR1 to EEACR1.

1 = EEPROM array block is protected.

0 = EEPROM array block is unprotected.

6.5 Low-Power Modes

The WAIT and STOP instructions can put the MCU in low power-consumption standby modes.

6.5.1 Wait Mode

The WAIT instruction does not affect the EEPROM. It is possible to program the EEPROM and put the MCU in wait mode. However, if the EEPROM is inactive, power can be reduced by setting the EEOFF bit before executing the WAIT instruction.

6.5.2 Stop Mode

The STOP instruction reduces the EEPROM power consumption to a minimum. The STOP instruction should not be executed while the high voltage is turned on (EEPGM = 1).

If stop mode is entered while program/erase is in progress, high voltage will be automatically turned off. However, the EEGPM bit will remain set. When stop mode is terminated, and if EEGPM is still set, the high voltage will be automatically turned back on. Program/erase time will need to be extended if program/erase is interrupted by entering stop mode.

The module requires a recovery time, t_{EESTOP} , to stabilize after leaving stop mode. Attempts to access the array during the recovery time will result in unpredictable behavior.

Section 7. EEPROM-2

7.1 Contents

7.2	Introduction	101
7.3	Features	102
7.4	Functional Description	102
7.4.1	EEPROM Programming	102
7.4.2	EEPROM Erasing	104
7.4.3	EEPROM Block Protection	106
7.4.4	EEPROM Redundant Mode	106
7.4.5	MCU Configuration	107
7.4.6	MC68HC908AS60 EEPROM Protect	107
7.4.7	EEPROM Control Register	108
7.4.8	EEPROM Non-Volatile Register and EEPROM Array Control Register	110
7.5	Low-Power Modes	112
7.5.1	Wait Mode	112
7.5.2	Stop Mode	112

7.2 Introduction

This section describes the electrically erasable programmable read-only memory (EEPROM-2) covering the address range \$0600–\$07FF.

7.3 Features

EEPROM-2 features include:

- Byte, block, or bulk erasable
- Non-volatile redundant array option
- Non-volatile block protection option
- Non-volatile MCU configuration bits
- On-chip charge pump for programming/erasing
- Security option

7.4 Functional Description

The 512 bytes of EEPROM-2 can be programmed or erased without an external voltage supply. EEPROM cells are protected with a non-volatile block protection option. These options are stored in the EEPROM non-volatile register (EENVR2) and are loaded into the EEPROM array configuration register after reset (EEACR2) or a read of EENVR2. Hardware interlocks are provided to protect stored data corruption from accidental programming/erasing.

7.4.1 EEPROM Programming

The unprogrammed state is a logic 1. Programming changes the state to a logic 0. Only valid EEPROM bytes in the non-protected blocks and EENVR2 can be programmed. When the array is configured in the redundant mode, programming the first 256 bytes also will program the last 256 bytes with the same data. Programming the EEPROM in the non-redundant mode is recommended. Program the data to both locations before entering redundant mode.

Follow this step-by-step procedure to program a byte of EEPROM:

1. Clear EERAS1 and EERAS0 and set EELAT in the EECTL. Set value of t_{EEPGM} . (See notes a and b.)
2. Write the desired data to any user EEPROM address.
3. Set the EEPGM bit. (See note c.)
4. Wait for a time, t_{EEPGM} , to program the byte.
5. Clear EEPGM bit.
6. Wait for a time, t_{EEFPV} , for the programming voltage to fall.
7. Clear EELAT bits. (See note d.)
8. Repeat steps 1 to 7 for more EEPROM programming.

Notes:

- a. EERAS1 and EERAS0 must be cleared for programming. Otherwise, the part will be in erase mode.
- b. Setting EELAT bit configures the address and data buses to latch data for programming the array. Only data with valid EEPROM address will be latched. If another consecutive valid EEPROM write occurs, this address and data will override the previous address and data. Any attempts to read other EEPROM data will read the latched data. If EELAT is set, other writes to the EECR2 will be allowed only after a valid EEPROM write.
- c. To ensure proper programming sequence, the EEPGM bit cannot be set if the EELAT bit is cleared and a non-EEPROM write has occurred. When EEPGM is set, the on-board charge pump generates the program voltage and applies it to the user EEPROM array. When the EEPGM bit is cleared, the program voltage is removed from the array and the internal charge pump is turned off.
- d. Any attempt to clear both EEPGM and EELAT bits with a single instruction will only clear EEPGM. This is to allow time for removal of high voltage from the EEPROM array.

7.4.2 EEPROM Erasing

The unprogrammed state is a logic 1. Only the valid EEPROM bytes in the non-protected blocks and EENVR2 can be erased. When the array is configured in the redundant mode, erasing the first 256 bytes also will erase the last 256 bytes.

Using this step-by-step procedure erases EEPROM:

1. Clear/set EERAS1 and EERAS0 to select byte/block/bulk erase, and set EELAT in EECR2. (See note a.)
2. Write any data to the desired address for byte erase, to any address in the desired block for block erase, or to any array address for bulk erase.
3. Set the EEPGM bit. (See note b.)
4. Wait for a time, $t_{EEPGM}/t_{EEBLOCK}/t_{EEBULK}$.
5. Clear EEPGM bit.
6. Wait for a time, t_{EEFPV} , for the erasing voltage to fall.
7. Clear EELAT bits. (See note c.)
8. Repeat steps 1 to 7 for more EEPROM byte/block erasing.

EEBPx bit must be cleared to erase EEPROM data in the corresponding block. If any EEBPx is set, the corresponding block cannot be erased and bulk erase mode does not apply.

Notes:

- a. Setting the EELAT bit configures the address and data buses to latch data for erasing the array. Only valid EEPROM addresses with their data will be latched. If another consecutive valid EEPROM write occurs, this address and data will override the previous address and data. In block erase mode, any EEPROM address in the block may be used in step 2. All locations within this block will be erased. In bulk erase mode, any EEPROM address may be used to erase the whole EEPROM. EENVR2 is not affected with block or bulk erase. Any attempts to read other EEPROM data will read the latched data. If EELAT is set, other writes to the EECR2 will be allowed after a valid EEPROM write.

- b. The EEPGM bit cannot be set if the EELAT bit is cleared and a non-EEPROM write has occurred. This is to ensure proper erasing sequence. Once EEPGM is set, the type of erase mode cannot be modified. If EEPGM is set, the onboard charge pump generates the erase voltage and applies it to the user EEPROM array. When the EEPGM bit is cleared, the erase voltage is removed from the array and the internal charge pump is turned off.
- c. Any attempt to clear both EEPGM and EELAT bits with a single instruction will only clear EEPGM. This is to allow time for removal of high voltage from the EEPROM array.

In general, all bits should be erased before being programmed. However, if program/erase cycling is of concern, minimize bit cycling in each EEPROM byte. If any bit in a byte requires change from a 0 to a 1, the byte needs be erased before programming. **Table 7-1** summarizes the conditions for erasing before programming

Table 7-1. EEPROM Program/Erase Cycling Reduction

EEPROM Data To Be Programmed	EEPROM Data Before Programming	Erase Before Programming?
0	0	No
0	1	No
1	0	Yes
1	1	No

7.4.3 EEPROM Block Protection

The 512 bytes of EEPROM are divided into four 128-byte blocks. Each of these blocks can be separately protected by EEBPx bit. Any attempt to program or erase memory locations within the protected block will not allow the program/erase voltage to be applied to the array. [Table 7-2](#) shows the address ranges within the blocks.

Table 7-2. EEPROM Array Address Blocks

Block Number (EEBPx)	Address Range
EEBP0	\$0600–\$067F
EEBP1	\$0680–\$06FF
EEBP2	\$0700–\$077F
EEBP3	\$0780–\$07FF

If the EEBPx bit is set, that corresponding address block is protected. These bits are effective after a reset or a read to the EENVR2 register. The block protect configuration can be modified by erasing/programming the corresponding bits in the EENVR2 register and then reading the EENVR2 register.

In redundant mode, EEBP3 and EEBP2 will have no meaning.

7.4.4 EEPROM Redundant Mode

To extend the EEPROM data retention, the array can be placed in redundant mode. In this mode, the first 256 bytes of user EEPROM array are mapped to the last 256 bytes. Reading, programming, and erasing of the first 256 EEPROM bytes will physically affect two bytes of EEPROM. Addressing the last 256 bytes will not be recognized. Block protection still applies but EEBP3 and EEBP2 are meaningless.

NOTE: *Programming the EEPROM in non-redundant mode and programming the data to its corresponding location before entering redundant mode is recommended.*

The EEPROM non-volatile register (EENVR2) contains configurations concerning block protection and redundancy. EENVR2 is physically located on the bottom of the EEPROM array. The contents are non-volatile and are not modified by reset. On reset, this special register loads the EEPROM configuration into a corresponding volatile EEPROM array configuration register (EEACR2). Thereafter, all reads to the EENVR2 will reload EEACR2.

The EEPROM configuration can be changed by programming/erasing the EENVR2 like a normal EEPROM byte. The new array configuration will take effect with a system reset or a read of the EENVR2.

7.4.5 MCU Configuration

The EEPROM non-volatile register (EENVR2) also contains general-purpose bits which can be used to enable/disable functions within the MCU which, for safety reasons, need to be controlled from non-volatile memory. On reset, this special register loads the MCU configuration into the volatile EEPROM array configuration register (EEACR2). Thereafter, all reads to the EENVR2 will reload EEACR2.

The MCU configuration can be changed by programming/erasing the EENVR2 like a normal EEPROM byte. Note that it is the users responsibility to program the EENVR2 register to the correct system requirements and verify it prior to use. The new array configuration will only take effect after a system reset or a read of the EENVR2.

7.4.6 MC68HC908AS60 EEPROM Protect

The MC68HC908AS60 has a special protect option which prevents program/erase access to memory locations \$06F0–\$06FF. This protect function is enabled by programming the EEPRTCT bit in the EENVR2 to 0.

In addition to the disabling of the program and erase operations on memory locations \$06F0–\$06FF, the enabling of the protect option has the following effects:

- Bulk and block erase modes are disabled.
- Programming and erasing of the EENVR are disabled.
- Unsecured locations (\$0600–\$06EF) can be erased using the single byte erase function as normal.
- Secured locations can be read as normal.
- Writing to a secured location no longer qualifies as a valid EEPROM write as detailed in [7.4.1 EEPROM Programming](#) note b and [7.4.2 EEPROM Erasing](#) note a.

NOTE: *Once armed, the security option is permanently enabled. As a consequence, all functions in the EENVR will remain in the state they were in immediately before the security was enabled.*

7.4.7 EEPROM Control Register

This read/write register controls programming/erasing of the array.

Address: \$FE19

	Bit 7	6	5	4	3	2	1	Bit 0
Read:	EEBCLK	0	EEOFF	EERAS1	EERAS0	EELAT	0	EEPGM
Write:								
Reset:	0	0	0	0	0	0	0	0

 = Unimplemented

Figure 7-1. EEPROM-2 Control Register (EECR2)

EEBCLK — EEPROM Bus Clock Enable Bit

This read/write bit determines which clock will be used to drive the internal charge pump for programming/erasing. Reset clears this bit.

1 = Bus clock drives charge pump.

0 = Internal RC oscillator drives charge pump.

NOTE: *It is recommended that the internal RC oscillator be used to drive the internal charge pump for applications that have a bus frequency of less than 8 MHz.*

EEOFF — EEPROM Power Down Bit

This read/write bit disables the EEPROM module for lower power consumption. Any attempts to access the array will give unpredictable results. Reset clears this bit.

- 1 = Disable EEPROM array
- 0 = Enable EEPROM array

NOTE: *The EEPROM requires a recovery time, t_{EEOFF} , to stabilize after clearing the EEOFF bit.*

EERAS1 and EERAS0 — Erase Bits

These read/write bits set the erase modes. Reset clears these bits.

Table 7-3. EEPROM Program/Erase Mode Select

EEBPx	EERAS1	EERAS0	MODE
0	0	0	Byte program
0	0	1	Byte erase
0	1	0	Block erase
0	1	1	Bulk erase
1	X	X	No erase/program

X = Don't care

EELAT — EEPROM Latch Control Bit

This read/write bit latches the address and data buses for programming the EEPROM array. EELAT cannot be cleared if EEPGM is still set. Reset clears this bit.

- 1 = Buses configured for EEPROM programming
- 0 = Buses configured for normal read operation

EEPGM — EEPROM Program/Erase Enable Bit

This read/write bit enables the internal charge pump and applies the programming/erasing voltage to the EEPROM array if the EELAT bit is set and a write to a valid EEPROM location has occurred. Reset clears the EEGPM bit.

- 1 = EEPROM programming/erasing power switched on
- 0 = EEPROM programming/erasing power switched off

NOTE: Writing logic 0s to both the EELAT and EEGPM bits with a single instruction will clear EEGPM only to allow time for the removal of high voltage.

7.4.8 EEPROM Non-Volatile Register and EEPROM Array Control Register

The EEPROM non-volatile register (EENVR2) and array control register (EEACR2) are shown in Figure 7-2 and Figure 7-3.

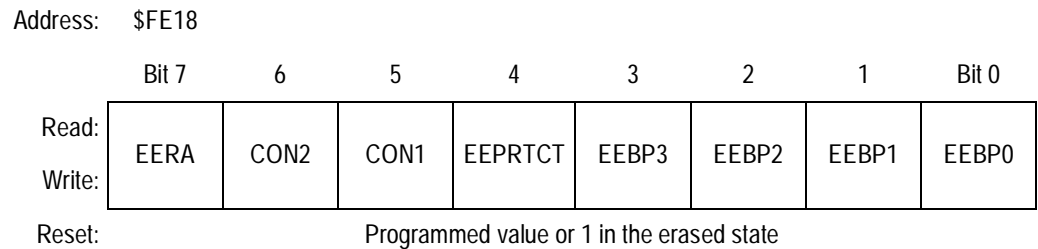

Figure 7-2. EEPROM-2 Non-Volatile Register (EENVR2)

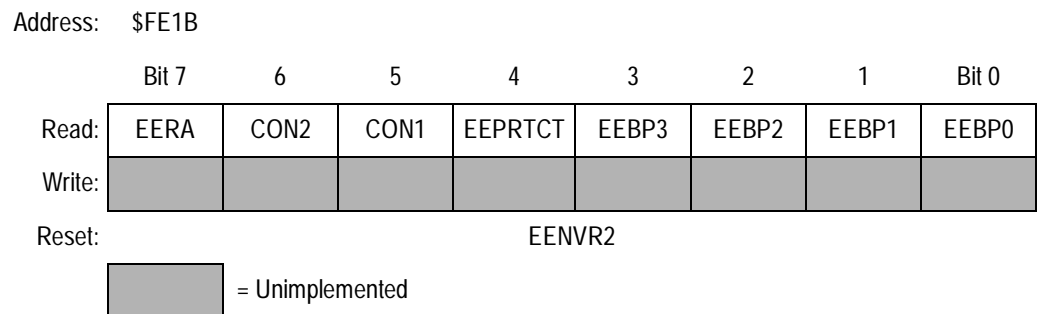

Figure 7-3. EEPROM-2 Array Control Register (EEACR2)

EERA — EEPROM Redundant Array Bit

This programmable/erasable/read bit in EENVR2 and read-only bit in EEACR2 configures the array in redundant mode. Reset loads EERA from EENVR2 to EEACR2.

1 = EEPROM array is in redundant mode configuration.

0 = EEPROM array is in normal mode configuration.

CON2 and CON1 — MCU Configuration Bits

These read/write bits can be used to enable/disable functions within the MCU. Reset loads CONx from EENVR2 to EEACR2.

NOTE: *The EEPROM protect feature is a write-once feature. Once the protection is enabled, it may not be disabled.*

EEPRTCT — EEPROM Protect Bit

This one-time programmable bit can be used to protect 16 bytes (\$6F0–\$6FF) from being erased or programmed.

1 = EEPROM protect disabled

0 = EEPROM protect enabled

EEBP3–EEBP0 — EEPROM Block Protection Bits

These read/write bits select blocks of EEPROM array from being programmed or erased. Reset loads EEBP3–EEBP0 from EENVR2 to EEACR2.

1 = EEPROM array block is protected.

0 = EEPROM array block is unprotected.

7.5 Low-Power Modes

The WAIT and STOP instructions can put the MCU in low power-consumption standby modes.

7.5.1 Wait Mode

The WAIT instruction does not affect the EEPROM. It is possible to program the EEPROM and put the MCU in wait mode. However, if the EEPROM is inactive, power can be reduced by setting the EEOFF bit before executing the WAIT instruction.

7.5.2 Stop Mode

The STOP instruction reduces the EEPROM power consumption to a minimum. The STOP instruction should not be executed while the high voltage is turned on (EEPGM = 1).

If stop mode is entered while program/erase is in progress, high voltage will be automatically turned off. However, the EEGPM bit will remain set. When stop mode is terminated, and if EEGPM is still set, the high voltage will be automatically turned back on. Program/erase time will need to be extended if program/erase is interrupted by entering stop mode.

The module requires a recovery time, t_{EESTOP} , to stabilize after leaving stop mode. Attempts to access the array during the recovery time will result in unpredictable behavior.

Section 8. Central Processor Unit (CPU)

8.1 Contents

8.2	Introduction	113
8.3	Features	114
8.4	CPU Registers	115
8.4.1	Accumulator (A)	116
8.4.2	Index Register (H:X)	116
8.4.3	Stack Pointer (SP)	117
8.4.4	Program Counter (PC)	118
8.4.5	Condition Code Register (CCR)	119
8.5	Arithmetic/Logic Unit (ALU)	121
8.6	Low-Power Modes	121
8.6.1	Wait Mode	121
8.6.2	Stop Mode	121
8.7	CPU During Break Interrupts	122
8.8	Instruction Set Summary	122
8.9	Opcode Map	130

8.2 Introduction

This section describes the central processor unit (CPU08). The M68HC08 CPU is an enhanced and fully object-code-compatible version of the M68HC05 CPU. The *CPU08 Reference Manual*, Motorola document order number CPU08RM/AD, contains a description of the CPU instruction set, addressing modes, and architecture.

8.3 Features

Features of the CPU08 include:

- Full upward, object-code compatibility with M68HC05 Family
- 16-bit stack pointer with stack manipulation instructions
- 16-bit index register with X-register manipulation instructions
- 8.4-MHz CPU internal bus frequency
- 64-Kbyte program/data memory space
- 16 addressing modes
- Memory-to-memory data moves without using accumulator
- Fast 8-bit by 8-bit multiply and 16-bit by 8-bit divide instructions
- Enhanced binary-coded decimal (BCD) data handling
- Modular architecture with expandable internal bus definition for extension of addressing range beyond 64 Kbytes
- Low-power stop and wait modes

8.4 CPU Registers

Figure 8-1 shows the five CPU registers. CPU registers are not part of the memory map.

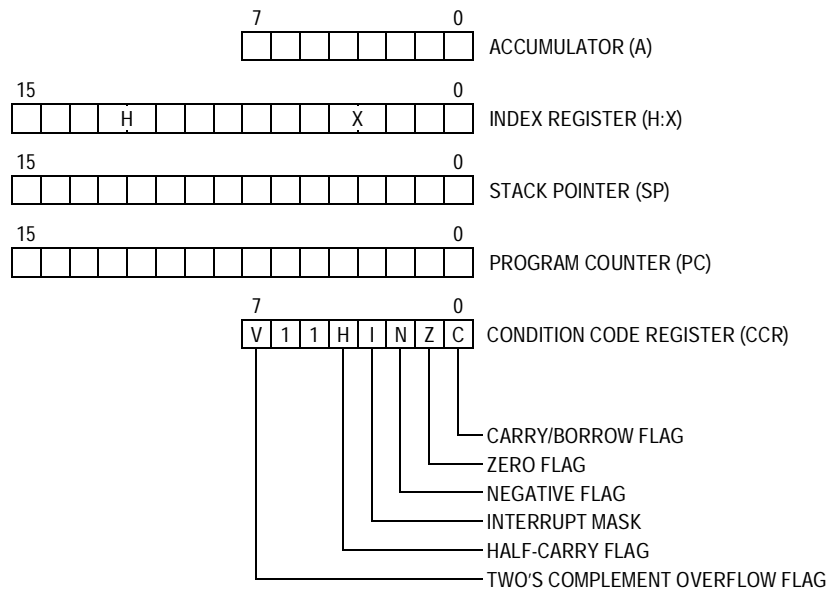

Figure 8-1. CPU Registers

8.4.1 Accumulator (A)

The accumulator is a general-purpose 8-bit register. The CPU uses the accumulator to hold operands and the results of arithmetic/logic operations.

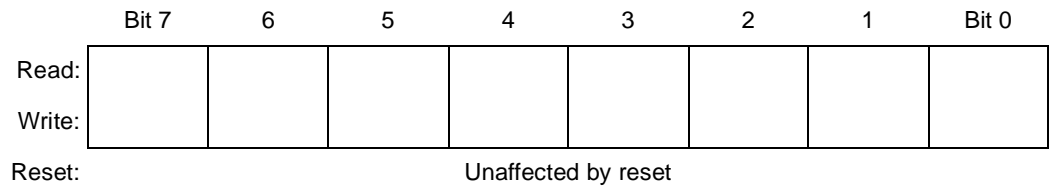

Figure 8-2. Accumulator (A)

8.4.2 Index Register (H:X)

The 16-bit index register allows indexed addressing of a 64-Kbyte memory space. H is the upper byte of the index register and X is the lower byte. H:X is the concatenated 16-bit index register.

In the indexed addressing modes, the CPU uses the contents of the index register to determine the conditional address of the operand.

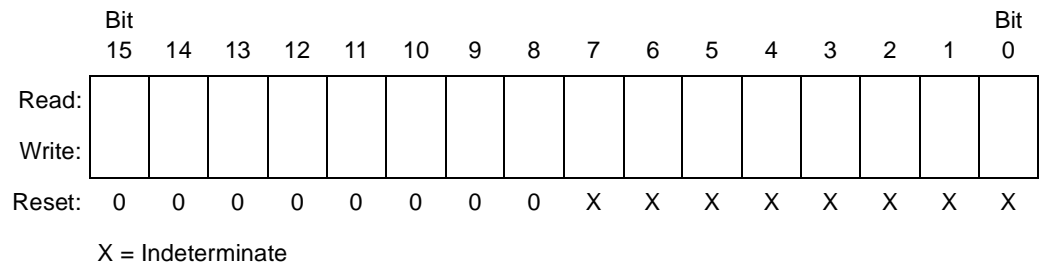

Figure 8-3. Index Register (H:X)

The index register can also be used as a temporary data storage location.

8.4.3 Stack Pointer (SP)

The stack pointer is a 16-bit register that contains the address of the next location on the stack. During a reset, the stack pointer is preset to \$00FF. The reset stack pointer (RSP) instruction sets the least-significant byte to \$FF and does not affect the most-significant byte. The stack pointer decrements as data is pushed onto the stack and increments as data is pulled from the stack.

In the stack pointer 8-bit offset and 16-bit offset addressing modes, the stack pointer can function as an index register to access data on the stack. The CPU uses the contents of the stack pointer to determine the conditional address of the operand.

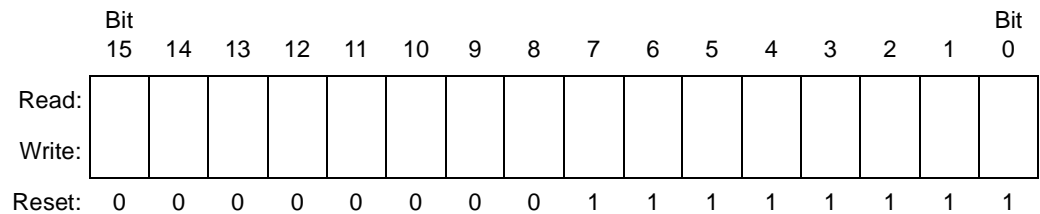

Figure 8-4. Stack Pointer (SP)

NOTE: *The location of the stack is arbitrary and may be relocated anywhere in RAM. Moving the SP out of page zero (\$0000–\$00FF) frees direct address (page zero) space. For correct operation, the stack pointer must point only to RAM locations.*

8.4.4 Program Counter (PC)

The program counter is a 16-bit register that contains the address of the next instruction or operand to be fetched.

Normally, the program counter automatically increments to the next sequential memory location every time an instruction or operand is fetched. Jump, branch, and interrupt operations load the program counter with an address other than that of the next sequential location.

During reset, the program counter is loaded with the reset vector address located at \$FFFE and \$FFFF. The vector address is the address of the first instruction to be executed after exiting the reset state.

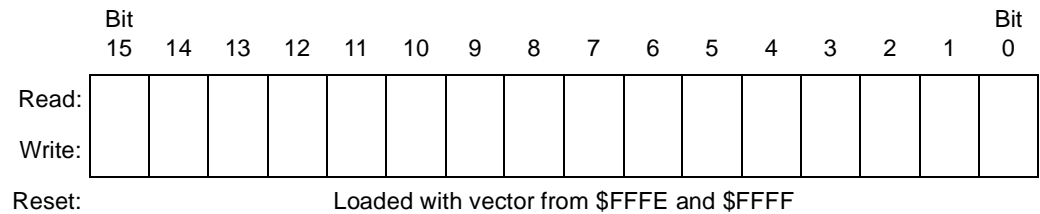

Figure 8-5. Program Counter (PC)

8.4.5 Condition Code Register (CCR)

The 8-bit condition code register contains the interrupt mask and five flags that indicate the results of the instruction just executed. Bits 6 and 5 are set permanently to 1.

	Bit 7	6	5	4	3	2	1	Bit 0
Read:	V	1	1	H	I	N	Z	C
Write:								
Reset:	X	1	1	X	1	X	X	X

X = Indeterminate

Figure 8-6. Condition Code Register (CCR)

V — Overflow Flag

The CPU sets the overflow flag when a two's complement overflow occurs. The signed branch instructions BGT, BGE, BLE, and BLT use the overflow flag.

- 1 = Overflow
- 0 = No overflow

H — Half-Carry Flag

The CPU sets the half-carry flag when a carry occurs between accumulator bits 3 and 4 during an ADD or ADC operation. The half-carry flag is required for binary-coded decimal (BCD) arithmetic operations. The DAA instruction uses the states of the H and C flags to determine the appropriate correction factor.

- 1 = Carry between bits 3 and 4
- 0 = No carry between bits 3 and 4

I — Interrupt Mask

When the interrupt mask is set, all maskable CPU interrupts are disabled. CPU interrupts are enabled when the interrupt mask is cleared. When a CPU interrupt occurs, the interrupt mask is set automatically after the CPU registers are saved on the stack, but before the interrupt vector is fetched.

- 1 = Interrupts disabled
- 0 = Interrupts enabled

NOTE: *To maintain M6805 compatibility, the upper byte of the index register (H) is not stacked automatically. If the interrupt service routine modifies H, then the user must stack and unstack H using the PSHH and PULH instructions.*

After the I bit is cleared, the highest-priority interrupt request is serviced first.

A return-from-interrupt (RTI) instruction pulls the CPU registers from the stack and restores the interrupt mask from the stack. After any reset, the interrupt mask is set and can be cleared only by the clear interrupt mask software instruction (CLI).

N — Negative Flag

The CPU sets the negative flag when an arithmetic operation, logic operation, or data manipulation produces a negative result, setting bit 7 of the result.

1 = Negative result

0 = Non-negative result

Z — Zero Flag

The CPU sets the zero flag when an arithmetic operation, logic operation, or data manipulation produces a result of \$00.

1 = Zero result

0 = Non-zero result

C — Carry/Borrow Flag

The CPU sets the carry/borrow flag when an addition operation produces a carry out of bit 7 of the accumulator or when a subtraction operation requires a borrow. Some instructions, such as bit test and branch, shift, and rotate, also clear or set the carry/borrow flag.

1 = Carry out of bit 7

0 = No carry out of bit 7

8.5 Arithmetic/Logic Unit (ALU)

The ALU performs the arithmetic and logic operations defined by the instruction set.

Refer to the *CPU08 Reference Manual* (Motorola document order number CPU08RM/AD) for a description of the instructions and addressing modes and more detail about CPU architecture.

8.6 Low-Power Modes

The WAIT and STOP instructions put the MCU in low power-consumption standby modes.

8.6.1 Wait Mode

The WAIT instruction:

- Clears the interrupt mask (I bit) in the condition code register, enabling interrupts. After exit from wait mode by interrupt, the I bit remains clear. After exit by reset, the I bit is set.
- Disables the CPU clock

8.6.2 Stop Mode

The STOP instruction:

- Clears the interrupt mask (I bit) in the condition code register, enabling external interrupts. After exit from stop mode by external interrupt, the I bit remains clear. After exit by reset, the I bit is set.
- Disables the CPU clock

After exiting stop mode, the CPU clock begins running after the oscillator stabilization delay.

8.7 CPU During Break Interrupts

If the break module is enabled, a break interrupt causes the CPU to execute the software interrupt instruction (SWI) at the completion of the current CPU instruction. See [Section 12. Break Module](#). The program counter vectors to \$FFFC–\$FFFD (\$FEFC–\$FEFD in monitor mode).

A return-from-interrupt instruction (RTI) in the break routine ends the break interrupt and returns the MCU to normal operation if the break interrupt has been deasserted.

8.8 Instruction Set Summary

[Table 8-1](#) provides a summary of the M68HC08 instruction set.

Table 8-1. Instruction Set Summary (Sheet 1 of 8)

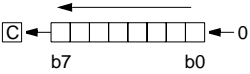
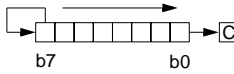
Source Form	Operation	Description	Effect on CCR						Address Mode	Opcode	Operand	Cycles
			V	H	I	N	Z	C				
ADC #opr ADC opr ADC opr ADC opr,X ADC opr,X ADC ,X ADC opr,SP ADC opr,SP	Add with Carry	$A \leftarrow (A) + (M) + (C)$	↑	↑	—	↑	↑	↑	IMM DIR EXT IX2 IX1 IX SP1 SP2	A9 B9 C9 D9 E9 F9 9EE9 9ED9	ii dd hh ll ee ff ff ff ff ee ff	2 3 4 4 3 2 4 5
ADD #opr ADD opr ADD opr ADD opr,X ADD opr,X ADD ,X ADD opr,SP ADD opr,SP	Add without Carry	$A \leftarrow (A) + (M)$	↑	↑	—	↑	↑	↑	IMM DIR EXT IX2 IX1 IX SP1 SP2	AB BB CB DB EB FB 9EEB 9EDB	ii dd hh ll ee ff ff ff ff ee ff	2 3 4 4 3 2 4 5
AIS #opr	Add Immediate Value (Signed) to SP	$SP \leftarrow (SP) + (16 \ll M)$	—	—	—	—	—	—	IMM	A7	ii	2
AIX #opr	Add Immediate Value (Signed) to H:X	$H:X \leftarrow (H:X) + (16 \ll M)$	—	—	—	—	—	—	IMM	AF	ii	2
AND #opr AND opr AND opr AND opr,X AND opr,X AND ,X AND opr,SP AND opr,SP	Logical AND	$A \leftarrow (A) \& (M)$	0	—	—	↑	↑	—	IMM DIR EXT IX2 IX1 IX SP1 SP2	A4 B4 C4 D4 E4 F4 9EE4 9ED4	ii dd hh ll ee ff ff ff ff ee ff	2 3 4 4 3 2 4 5
ASL opr ASLA ASLX ASL opr,X ASL ,X ASL opr,SP	Arithmetic Shift Left (Same as LSL)		↑	—	—	↑	↑	↑	DIR INH INH IX1 IX SP1	38 48 58 68 78 9E68	dd ff ff	4 1 1 4 3 5
ASR opr ASRA ASRX ASR opr,X ASR opr,X ASR opr,SP	Arithmetic Shift Right		↑	—	—	↑	↑	↑	DIR INH INH IX1 IX SP1	37 47 57 67 77 9E67	dd ff ff	4 1 1 4 3 5
BCC rel	Branch if Carry Bit Clear	$PC \leftarrow (PC) + 2 + rel \text{ ? } (C) = 0$	—	—	—	—	—	—	REL	24	rr	3
BCLR n, opr	Clear Bit n in M	$M_n \leftarrow 0$	—	—	—	—	—	—	DIR (b0) DIR (b1) DIR (b2) DIR (b3) DIR (b4) DIR (b5) DIR (b6) DIR (b7)	11 13 15 17 19 1B 1D 1F	dd dd dd dd dd dd dd dd	4 4 4 4 4 4 4 4

Central Processor Unit (CPU)

Table 8-1. Instruction Set Summary (Sheet 2 of 8)

Source Form	Operation	Description	Effect on CCR						Address Mode	Opcode	Operand	Cycles
			V	H	I	N	Z	C				
BCS <i>rel</i>	Branch if Carry Bit Set (Same as BLO)	$PC \leftarrow (PC) + 2 + rel ? (C) = 1$	-	-	-	-	-	-	REL	25	rr	3
BEQ <i>rel</i>	Branch if Equal	$PC \leftarrow (PC) + 2 + rel ? (Z) = 1$	-	-	-	-	-	-	REL	27	rr	3
BGE <i>opr</i>	Branch if Greater Than or Equal To (Signed Operands)	$PC \leftarrow (PC) + 2 + rel ? (N \oplus V) = 0$	-	-	-	-	-	-	REL	90	rr	3
BGT <i>opr</i>	Branch if Greater Than (Signed Operands)	$PC \leftarrow (PC) + 2 + rel ? (Z) (N \oplus V) = 0$	-	-	-	-	-	-	REL	92	rr	3
BHCC <i>rel</i>	Branch if Half Carry Bit Clear	$PC \leftarrow (PC) + 2 + rel ? (H) = 0$	-	-	-	-	-	-	REL	28	rr	3
BHCS <i>rel</i>	Branch if Half Carry Bit Set	$PC \leftarrow (PC) + 2 + rel ? (H) = 1$	-	-	-	-	-	-	REL	29	rr	3
BHI <i>rel</i>	Branch if Higher	$PC \leftarrow (PC) + 2 + rel ? (C) (Z) = 0$	-	-	-	-	-	-	REL	22	rr	3
BHS <i>rel</i>	Branch if Higher or Same (Same as BCC)	$PC \leftarrow (PC) + 2 + rel ? (C) = 0$	-	-	-	-	-	-	REL	24	rr	3
BIH <i>rel</i>	Branch if \overline{IRQ} Pin High	$PC \leftarrow (PC) + 2 + rel ? \overline{IRQ} = 1$	-	-	-	-	-	-	REL	2F	rr	3
BIL <i>rel</i>	Branch if \overline{IRQ} Pin Low	$PC \leftarrow (PC) + 2 + rel ? \overline{IRQ} = 0$	-	-	-	-	-	-	REL	2E	rr	3
BIT # <i>opr</i> BIT <i>opr</i> BIT <i>opr</i> BIT <i>opr</i> ,X BIT <i>opr</i> ,X BIT ,X BIT <i>opr</i> ,SP BIT <i>opr</i> ,SP	Bit Test	(A) & (M)	0	-	-	↓	↓	-	IMM DIR EXT IX2 IX1 IX SP1 SP2	A5 B5 C5 D5 E5 F5 9EE5 9ED5	ii dd hh ll ee ff ff ff ff ff	2 3 4 4 3 2 4 5
BLE <i>opr</i>	Branch if Less Than or Equal To (Signed Operands)	$PC \leftarrow (PC) + 2 + rel ? (Z) (N \oplus V) = 1$	-	-	-	-	-	-	REL	93	rr	3
BLO <i>rel</i>	Branch if Lower (Same as BCS)	$PC \leftarrow (PC) + 2 + rel ? (C) = 1$	-	-	-	-	-	-	REL	25	rr	3
BLS <i>rel</i>	Branch if Lower or Same	$PC \leftarrow (PC) + 2 + rel ? (C) (Z) = 1$	-	-	-	-	-	-	REL	23	rr	3
BLT <i>opr</i>	Branch if Less Than (Signed Operands)	$PC \leftarrow (PC) + 2 + rel ? (N \oplus V) = 1$	-	-	-	-	-	-	REL	91	rr	3
BMC <i>rel</i>	Branch if Interrupt Mask Clear	$PC \leftarrow (PC) + 2 + rel ? (I) = 0$	-	-	-	-	-	-	REL	2C	rr	3
BMI <i>rel</i>	Branch if Minus	$PC \leftarrow (PC) + 2 + rel ? (N) = 1$	-	-	-	-	-	-	REL	2B	rr	3
BMS <i>rel</i>	Branch if Interrupt Mask Set	$PC \leftarrow (PC) + 2 + rel ? (I) = 1$	-	-	-	-	-	-	REL	2D	rr	3
BNE <i>rel</i>	Branch if Not Equal	$PC \leftarrow (PC) + 2 + rel ? (Z) = 0$	-	-	-	-	-	-	REL	26	rr	3
BPL <i>rel</i>	Branch if Plus	$PC \leftarrow (PC) + 2 + rel ? (N) = 0$	-	-	-	-	-	-	REL	2A	rr	3
BRA <i>rel</i>	Branch Always	$PC \leftarrow (PC) + 2 + rel$	-	-	-	-	-	-	REL	20	rr	3
BRCLR <i>n,opr,rel</i>	Branch if Bit <i>n</i> in M Clear	$PC \leftarrow (PC) + 3 + rel ? (Mn) = 0$	-	-	-	-	-	↓	DIR (b0) DIR (b1) DIR (b2) DIR (b3) DIR (b4) DIR (b5) DIR (b6) DIR (b7)	01 03 05 07 09 0B 0D 0F	dd rr dd rr dd rr dd rr dd rr dd rr dd rr dd rr	5 5 5 5 5 5 5 5

Table 8-1. Instruction Set Summary (Sheet 3 of 8)

Source Form	Operation	Description	Effect on CCR						Address Mode	Opcode	Operand	Cycles
			V	H	I	N	Z	C				
BRN <i>rel</i>	Branch Never	$PC \leftarrow (PC) + 2$	-	-	-	-	-	-	REL	21	rr	3
BRSET <i>n,opr,rel</i>	Branch if Bit <i>n</i> in M Set	$PC \leftarrow (PC) + 3 + rel ? (Mn) = 1$	-	-	-	-	-	↑	DIR (b0) DIR (b1) DIR (b2) DIR (b3) DIR (b4) DIR (b5) DIR (b6) DIR (b7)	00 02 04 06 08 0A 0C 0E	dd rr dd rr dd rr dd rr dd rr dd rr dd rr dd rr	5 5 5 5 5 5 5 5
BSET <i>n,opr</i>	Set Bit <i>n</i> in M	$Mn \leftarrow 1$	-	-	-	-	-	-	DIR (b0) DIR (b1) DIR (b2) DIR (b3) DIR (b4) DIR (b5) DIR (b6) DIR (b7)	10 12 14 16 18 1A 1C 1E	dd dd dd dd dd dd dd dd	4 4 4 4 4 4 4 4
BSR <i>rel</i>	Branch to Subroutine	$PC \leftarrow (PC) + 2$; push (PCL) $SP \leftarrow (SP) - 1$; push (PCH) $SP \leftarrow (SP) - 1$ $PC \leftarrow (PC) + rel$	-	-	-	-	-	-	REL	AD	rr	4
CBEQ <i>opr,rel</i> CBEQA # <i>opr,rel</i> CBEQX # <i>opr,rel</i> CBEQ <i>opr,X+,rel</i> CBEQ <i>X+,rel</i> CBEQ <i>opr,SP,rel</i>	Compare and Branch if Equal	$PC \leftarrow (PC) + 3 + rel ? (A) - (M) = \00 $PC \leftarrow (PC) + 3 + rel ? (A) - (M) = \00 $PC \leftarrow (PC) + 3 + rel ? (X) - (M) = \00 $PC \leftarrow (PC) + 3 + rel ? (A) - (M) = \00 $PC \leftarrow (PC) + 2 + rel ? (A) - (M) = \00 $PC \leftarrow (PC) + 4 + rel ? (A) - (M) = \00	-	-	-	-	-	-	DIR IMM IMM IX1+ IX+ SP1	31 41 51 61 71 9E61	dd rr ii rr ii rr ff rr rr ff rr	5 4 4 5 4 6
CLC	Clear Carry Bit	$C \leftarrow 0$	-	-	-	-	-	0	INH	98		1
CLI	Clear Interrupt Mask	$I \leftarrow 0$	-	-	0	-	-	-	INH	9A		2
CLR <i>opr</i> CLRA CLR X CLR H CLR <i>opr,X</i> CLR <i>,X</i> CLR <i>opr,SP</i>	Clear	$M \leftarrow \$00$ $A \leftarrow \$00$ $X \leftarrow \$00$ $H \leftarrow \$00$ $M \leftarrow \$00$ $M \leftarrow \$00$ $M \leftarrow \$00$	0	-	-	0	1	-	DIR INH INH INH IX1 IX SP1	3F 4F 5F 8C 6F 7F 9E6F	dd ff ff ff	3 1 1 1 3 2 4
CMP # <i>opr</i> CMP <i>opr</i> CMP <i>opr</i> CMP <i>opr,X</i> CMP <i>opr,X</i> CMP <i>,X</i> CMP <i>opr,SP</i> CMP <i>opr,SP</i>	Compare A with M	$(A) - (M)$	↑	-	-	↑	↑	↑	IMM DIR EXT IX2 IX1 IX SP1 SP2	A1 B1 C1 D1 E1 F1 9EE1 9ED1	ii dd hh ll ee ff ff ff ff ff ee ff	2 3 4 4 3 2 4 5

Central Processor Unit (CPU)

Table 8-1. Instruction Set Summary (Sheet 4 of 8)

Source Form	Operation	Description	Effect on CCR						Address Mode	Opcode	Operand	Cycles
			V	H	I	N	Z	C				
COM <i>opr</i> COMA COMX COM <i>opr</i> ,X COM ,X COM <i>opr</i> ,SP	Complement (One's Complement)	M ← (M) = \$FF - (M) A ← (A) = \$FF - (M) X ← (X) = \$FF - (M) M ← (M) = \$FF - (M) M ← (M) = \$FF - (M) M ← (M) = \$FF - (M)	0	-	-	↑	↑	1	DIR INH INH IX1 IX SP1	33 43 53 63 73 9E63	dd ff ff	4 1 1 4 3 5
CPHX # <i>opr</i> CPHX <i>opr</i>	Compare H:X with M	(H:X) - (M:M + 1)	↑	-	-	↑	↑	↑	IMM DIR	65 75	ii ii+1 dd	3 4
CPX # <i>opr</i> CPX <i>opr</i> CPX <i>opr</i> CPX ,X CPX <i>opr</i> ,X CPX <i>opr</i> ,X CPX <i>opr</i> ,SP CPX <i>opr</i> ,SP	Compare X with M	(X) - (M)	↑	-	-	↑	↑	↑	IMM DIR EXT IX2 IX1 IX SP1 SP2	A3 B3 C3 D3 E3 F3 9EE3 9ED3	ii dd hh ll ee ff ff ff ff ee ff	2 3 4 4 3 2 4 5
DAA	Decimal Adjust A	(A) ₁₀	U	-	-	↑	↑	↑	INH	72		2
DBNZ <i>opr</i> , <i>rel</i> DBNZA <i>rel</i> DBNZX <i>rel</i> DBNZ <i>opr</i> ,X, <i>rel</i> DBNZ X, <i>rel</i> DBNZ <i>opr</i> ,SP, <i>rel</i>	Decrement and Branch if Not Zero	A ← (A) - 1 or M ← (M) - 1 or X ← (X) - 1 PC ← (PC) + 3 + <i>rel</i> ? (result) ≠ 0 PC ← (PC) + 2 + <i>rel</i> ? (result) ≠ 0 PC ← (PC) + 2 + <i>rel</i> ? (result) ≠ 0 PC ← (PC) + 3 + <i>rel</i> ? (result) ≠ 0 PC ← (PC) + 2 + <i>rel</i> ? (result) ≠ 0 PC ← (PC) + 4 + <i>rel</i> ? (result) ≠ 0	-	-	-	-	-	-	DIR INH INH IX1 IX SP1	3B 4B 5B 6B 7B 9E6B	dd rr rr rr ff rr rr ff rr	5 3 3 5 4 6
DEC <i>opr</i> DECA DECX DEC <i>opr</i> ,X DEC ,X DEC <i>opr</i> ,SP	Decrement	M ← (M) - 1 A ← (A) - 1 X ← (X) - 1 M ← (M) - 1 M ← (M) - 1 M ← (M) - 1	↑	-	-	↑	↑	-	DIR INH INH IX1 IX SP1	3A 4A 5A 6A 7A 9E6A	dd ff ff	4 1 1 4 3 5
DIV	Divide	A ← (H:A)/(X) H ← Remainder	-	-	-	-	↑	↑	INH	52		7
EOR # <i>opr</i> EOR <i>opr</i> EOR <i>opr</i> EOR <i>opr</i> ,X EOR <i>opr</i> ,X EOR ,X EOR <i>opr</i> ,SP EOR <i>opr</i> ,SP	Exclusive OR M with A	A ← (A ⊕ M)	0	-	-	↑	↑	-	IMM DIR EXT IX2 IX1 IX SP1 SP2	A8 B8 C8 D8 E8 F8 9EE8 9ED8	ii dd hh ll ee ff ff ff ff ee ff	2 3 4 4 3 2 4 5
INC <i>opr</i> INCA INCX INC <i>opr</i> ,X INC ,X INC <i>opr</i> ,SP	Increment	M ← (M) + 1 A ← (A) + 1 X ← (X) + 1 M ← (M) + 1 M ← (M) + 1 M ← (M) + 1	↑	-	-	↑	↑	-	DIR INH INH IX1 IX SP1	3C 4C 5C 6C 7C 9E6C	dd ff ff	4 1 1 4 3 5

Table 8-1. Instruction Set Summary (Sheet 5 of 8)

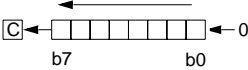
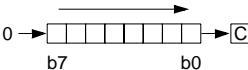
Source Form	Operation	Description	Effect on CCR						Address Mode	Opcode	Operand	Cycles
			V	H	I	N	Z	C				
JMP <i>opr</i> JMP <i>opr</i> JMP <i>opr</i> ,X JMP <i>opr</i> ,X JMP ,X	Jump	PC ← Jump Address	-	-	-	-	-	-	DIR EXT IX2 IX1 IX	BC CC DC EC FC	dd hh ll ee ff ff	2 3 4 3 2
JSR <i>opr</i> JSR <i>opr</i> JSR <i>opr</i> ,X JSR <i>opr</i> ,X JSR ,X	Jump to Subroutine	PC ← (PC) + <i>n</i> (<i>n</i> = 1, 2, or 3) Push (PCL); SP ← (SP) - 1 Push (PCH); SP ← (SP) - 1 PC ← Unconditional Address	-	-	-	-	-	-	DIR EXT IX2 IX1 IX	BD CD DD ED FD	dd hh ll ee ff ff	4 5 6 5 4
LDA # <i>opr</i> LDA <i>opr</i> LDA <i>opr</i> LDA <i>opr</i> ,X LDA <i>opr</i> ,X LDA ,X LDA <i>opr</i> ,SP LDA <i>opr</i> ,SP	Load A from M	A ← (M)	0	-	-	↑	↓	-	IMM DIR EXT IX2 IX1 IX SP1 SP2	A6 B6 C6 D6 E6 F6 9EE6 9ED6	ii dd hh ll ee ff ff	2 3 4 4 3 2 4 5
LDHX # <i>opr</i> LDHX <i>opr</i>	Load H:X from M	H:X ← (M:M + 1)	0	-	-	↑	↓	-	IMM DIR	45 55	ii jj dd	3 4
LDX # <i>opr</i> LDX <i>opr</i> LDX <i>opr</i> LDX <i>opr</i> ,X LDX <i>opr</i> ,X LDX ,X LDX <i>opr</i> ,SP LDX <i>opr</i> ,SP	Load X from M	X ← (M)	0	-	-	↑	↓	-	IMM DIR EXT IX2 IX1 IX SP1 SP2	AE BE CE DE EE FE 9EEE 9EDE	ii dd hh ll ee ff ff	2 3 4 4 3 2 4 5
LSL <i>opr</i> LSLA LSLX LSL <i>opr</i> ,X LSL ,X LSL <i>opr</i> ,SP	Logical Shift Left (Same as ASL)		↑	-	-	↓	↓	↓	DIR INH INH IX1 IX SP1	38 48 58 68 78 9E68	dd ff	4 1 1 4 3 5
LSR <i>opr</i> LSRA LSRX LSR <i>opr</i> ,X LSR ,X LSR <i>opr</i> ,SP	Logical Shift Right		↑	-	-	0	↑	↓	DIR INH INH IX1 IX SP1	34 44 54 64 74 9E64	dd ff	4 1 1 4 3 5
MOV <i>opr</i> , <i>opr</i> MOV <i>opr</i> ,X+ MOV # <i>opr</i> , <i>opr</i> MOV X+, <i>opr</i>	Move	(M) _{Destination} ← (M) _{Source} H:X ← (H:X) + 1 (IX+D, DIX+)	0	-	-	↑	↓	-	DD DIX+ IMD IX+D	4E 5E 6E 7E	dd dd ii dd dd	5 4 4 4
MUL	Unsigned multiply	X:A ← (X) × (A)	-	0	-	-	-	0	INH	42		5

Central Processor Unit (CPU)

Table 8-1. Instruction Set Summary (Sheet 6 of 8)

Source Form	Operation	Description	Effect on CCR						Address Mode	Opcode	Operand	Cycles
			V	H	I	N	Z	C				
NEG <i>opr</i> NEGA NEGX NEG <i>opr,X</i> NEG ,X NEG <i>opr,SP</i>	Negate (Two's Complement)	$M \leftarrow -(M) = \$00 - (M)$ $A \leftarrow -(A) = \$00 - (A)$ $X \leftarrow -(X) = \$00 - (X)$ $M \leftarrow -(M) = \$00 - (M)$ $M \leftarrow -(M) = \$00 - (M)$	↓	-	-	↓	↓	↓	DIR INH INH IX1 IX SP1	30 40 50 60 70 9E60	dd ff ff	4 1 1 4 3 5
NOP	No Operation	None	-	-	-	-	-	-	INH	9D		1
NSA	Nibble Swap A	$A \leftarrow (A[3:0]:A[7:4])$	-	-	-	-	-	-	INH	62		3
ORA # <i>opr</i> ORA <i>opr</i> ORA <i>opr</i> ORA <i>opr,X</i> ORA <i>opr,X</i> ORA ,X ORA <i>opr,SP</i> ORA <i>opr,SP</i>	Inclusive OR A and M	$A \leftarrow (A) (M)$	0	-	-	↓	↓	-	IMM DIR EXT IX2 IX1 IX SP1 SP2	AA BA CA DA EA FA 9EEA 9EDA	ii dd hh ll ee ff ff ff ff ee ff	2 3 4 4 3 2 4 5
PSHA	Push A onto Stack	Push (A); $SP \leftarrow (SP) - 1$	-	-	-	-	-	-	INH	87		2
PSHH	Push H onto Stack	Push (H); $SP \leftarrow (SP) - 1$	-	-	-	-	-	-	INH	8B		2
PSHX	Push X onto Stack	Push (X); $SP \leftarrow (SP) - 1$	-	-	-	-	-	-	INH	89		2
PULA	Pull A from Stack	$SP \leftarrow (SP) + 1$; Pull (A)	-	-	-	-	-	-	INH	86		2
PULH	Pull H from Stack	$SP \leftarrow (SP) + 1$; Pull (H)	-	-	-	-	-	-	INH	8A		2
PULX	Pull X from Stack	$SP \leftarrow (SP) + 1$; Pull (X)	-	-	-	-	-	-	INH	88		2
ROL <i>opr</i> ROLA ROLX ROL <i>opr,X</i> ROL ,X ROL <i>opr,SP</i>	Rotate Left through Carry		↓	-	-	↓	↓	↓	DIR INH INH IX1 IX SP1	39 49 59 69 79 9E69	dd ff ff	4 1 1 4 3 5
ROR <i>opr</i> RORA RORX ROR <i>opr,X</i> ROR ,X ROR <i>opr,SP</i>	Rotate Right through Carry		↓	-	-	↓	↓	↓	DIR INH INH IX1 IX SP1	36 46 56 66 76 9E66	dd ff ff	4 1 1 4 3 5
RSP	Reset Stack Pointer	$SP \leftarrow \$FF$	-	-	-	-	-	-	INH	9C		1
RTI	Return from Interrupt	$SP \leftarrow (SP) + 1$; Pull (CCR) $SP \leftarrow (SP) + 1$; Pull (A) $SP \leftarrow (SP) + 1$; Pull (X) $SP \leftarrow (SP) + 1$; Pull (PCH) $SP \leftarrow (SP) + 1$; Pull (PCL)	↓	↓	↓	↓	↓	↓	INH	80		7
RTS	Return from Subroutine	$SP \leftarrow SP + 1$; Pull (PCH) $SP \leftarrow SP + 1$; Pull (PCL)	-	-	-	-	-	-	INH	81		4

Freescale Semiconductor, Inc.

Table 8-1. Instruction Set Summary (Sheet 7 of 8)

Source Form	Operation	Description	Effect on CCR						Address Mode	Opcode	Operand	Cycles
			V	H	I	N	Z	C				
SBC #opr SBC opr SBC opr SBC opr,X SBC opr,X SBC ,X SBC opr,SP SBC opr,SP	Subtract with Carry	$A \leftarrow (A) - (M) - (C)$	↑	-	-	↑	↑	↑	IMM DIR EXT IX2 IX1 IX SP1 SP2	A2 B2 C2 D2 E2 F2 9EE2 9ED2	ii dd hh ll ee ff ff ff ff ee ff	2 3 4 4 3 2 4 5
SEC	Set Carry Bit	$C \leftarrow 1$	-	-	-	-	-	1	INH	99		1
SEI	Set Interrupt Mask	$I \leftarrow 1$	-	-	1	-	-	-	INH	9B		2
STA opr STA opr STA opr,X STA opr,X STA ,X STA opr,SP STA opr,SP	Store A in M	$M \leftarrow (A)$	0	-	-	↑	↑	-	DIR EXT IX2 IX1 IX SP1 SP2	B7 C7 D7 E7 F7 9EE7 9ED7	dd hh ll ee ff ff ff ff ee ff	3 4 4 3 2 4 5
STHX opr	Store H:X in M	$(M:M + 1) \leftarrow (H:X)$	0	-	-	↑	↑	-	DIR	35	dd	4
STOP	Enable \overline{IRQ} Pin; Stop Oscillator	$I \leftarrow 0$; Stop Oscillator	-	-	0	-	-	-	INH	8E		1
STX opr STX opr STX opr,X STX opr,X STX ,X STX opr,SP STX opr,SP	Store X in M	$M \leftarrow (X)$	0	-	-	↑	↑	-	DIR EXT IX2 IX1 IX SP1 SP2	BF CF DF EF FF 9EEF 9EDF	dd hh ll ee ff ff ff ff ee ff	3 4 4 3 2 4 5
SUB #opr SUB opr SUB opr SUB opr,X SUB opr,X SUB ,X SUB opr,SP SUB opr,SP	Subtract	$A \leftarrow (A) - (M)$	↑	-	-	↑	↑	↑	IMM DIR EXT IX2 IX1 IX SP1 SP2	A0 B0 C0 D0 E0 F0 9EE0 9ED0	ii dd hh ll ee ff ff ff ff ee ff	2 3 4 4 3 2 4 5
SWI	Software Interrupt	PC \leftarrow (PC) + 1; Push (PCL) SP \leftarrow (SP) - 1; Push (PCH) SP \leftarrow (SP) - 1; Push (X) SP \leftarrow (SP) - 1; Push (A) SP \leftarrow (SP) - 1; Push (CCR) SP \leftarrow (SP) - 1; I \leftarrow 1 PCH \leftarrow Interrupt Vector High Byte PCL \leftarrow Interrupt Vector Low Byte	-	-	1	-	-	-	INH	83		9
TAP	Transfer A to CCR	$CCR \leftarrow (A)$	↑	↑	↑	↑	↑	↑	INH	84		2
TAX	Transfer A to X	$X \leftarrow (A)$	-	-	-	-	-	-	INH	97		1
TPA	Transfer CCR to A	$A \leftarrow (CCR)$	-	-	-	-	-	-	INH	85		1

Table 8-1. Instruction Set Summary (Sheet 8 of 8)

Source Form	Operation	Description	Effect on CCR						Address Mode	Opcode	Operand	Cycles
			V	H	I	N	Z	C				
TST <i>opr</i> TSTA TSTX TST <i>opr,X</i> TST ,X TST <i>opr,SP</i>	Test for Negative or Zero	(A) – \$00 or (X) – \$00 or (M) – \$00	0	–	–	↕	↕	–	DIR INH INH IX1 IX SP1	3D 4D 5D 6D 7D 9E6D	dd ff ff	3 1 1 3 2 4
TSX	Transfer SP to H:X	H:X ← (SP) + 1	–	–	–	–	–	–	INH	95		2
TXA	Transfer X to A	A ← (X)	–	–	–	–	–	–	INH	9F		1
TXS	Transfer H:X to SP	(SP) ← (H:X) – 1	–	–	–	–	–	–	INH	94		2

- | | | | |
|-------|---|------------|---|
| A | Accumulator | <i>n</i> | Any bit |
| C | Carry/borrow bit | <i>opr</i> | Operand (one or two bytes) |
| CCR | Condition code register | PC | Program counter |
| dd | Direct address of operand | PCH | Program counter high byte |
| dd rr | Direct address of operand and relative offset of branch instruction | PCL | Program counter low byte |
| DD | Direct to direct addressing mode | REL | Relative addressing mode |
| DIR | Direct addressing mode | <i>rel</i> | Relative program counter offset byte |
| DIX+ | Direct to indexed with post increment addressing mode | rr | Relative program counter offset byte |
| ee ff | High and low bytes of offset in indexed, 16-bit offset addressing | SP1 | Stack pointer, 8-bit offset addressing mode |
| EXT | Extended addressing mode | SP2 | Stack pointer 16-bit offset addressing mode |
| ff | Offset byte in indexed, 8-bit offset addressing | SP | Stack pointer |
| H | Half-carry bit | U | Undefined |
| H | Index register high byte | V | Overflow bit |
| hh ll | High and low bytes of operand address in extended addressing | X | Index register low byte |
| I | Interrupt mask | Z | Zero bit |
| ii | Immediate operand byte | & | Logical AND |
| IMD | Immediate source to direct destination addressing mode | | Logical OR |
| IMM | Immediate addressing mode | ⊕ | Logical EXCLUSIVE OR |
| INH | Inherent addressing mode | () | Contents of |
| IX | Indexed, no offset addressing mode | –() | Negation (two's complement) |
| IX+ | Indexed, no offset, post increment addressing mode | # | Immediate value |
| IX+D | Indexed with post increment to direct addressing mode | « | Sign extend |
| IX1 | Indexed, 8-bit offset addressing mode | ← | Loaded with |
| IX1+ | Indexed, 8-bit offset, post increment addressing mode | ? | If |
| IX2 | Indexed, 16-bit offset addressing mode | : | Concatenated with |
| M | Memory location | ↕ | Set or cleared |
| N | Negative bit | — | Not affected |

8.9 Opcode Map

The opcode map is provided in [Table 8-2](#).

Table 8-2. Opcode Map

MSB LSB	Bit Manipulation			Branch			Read-Modify-Write			Control			Register/Memory					IX		
	DIR	DIR	REL	REL	DIR	REL	INH	INH	IX	INH	INH	IMM	DIR	EXT	IX2	SP2	IX1		SP1	
0	BRSET0 3 DIR	BSET0 4 DIR	BRA 2 REL	NEG 2 DIR	NEG 1 INH	NEG 1 INH	NEG 1 INH	NEG 1 INH	NEG 1 IX	RTI 1 INH	BGE 3 REL	SUB 2 IMM	SUB 3 DIR	SUB 3 EXT	SUB 4 IX2	SUB 5 SP2	SUB 3 IX1	SUB 4 SP1	9EE	F
1	BRCLR0 3 DIR	BCLR0 4 DIR	BRI 2 REL	CBEQ 3 DIR	CBEQ 3 IMM	CBEQ 3 IMM	CBEQ 3 IMM	CBEQ 3 IX+	CBEQ 2 IX+	RTS 1 INH	BIT 2 REL	CMP 2 IMM	CMP 2 DIR	CMP 3 EXT	CMP 4 IX2	CMP 5 SP2	CMP 2 IX1	CMP 3 SP1		CHMP IX
2	BRSET1 3 DIR	BSET1 4 DIR	BHI 2 REL	MUL 3 REL	DIV 1 INH	DIV 1 INH	DIV 1 INH	NSA 1 INH	DAI 1 INH		BGT 2 REL	SBC 2 IMM	SBC 2 DIR	SBC 3 EXT	SBC 4 IX2	SBC 5 SP2	SBC 3 IX1	SBC 4 SP1		SBC IX
3	BRCLR1 3 DIR	BCLR1 4 DIR	BLS 2 REL	COM 3 DIR	COM 1 INH	COM 1 INH	COM 1 INH	COM 2 IX+	COM 3 SP1	SWI 1 INH	BLE 3 REL	CPX 2 IMM	CPX 2 DIR	CPX 3 EXT	CPX 4 IX2	CPX 5 SP2	CPX 3 IX1	CPX 4 SP1		CPX IX
4	BRSET2 3 DIR	BSET2 4 DIR	BCC 2 REL	LSR 3 DIR	LSR 1 INH	LSR 1 INH	LSR 1 INH	LSR 2 IX+	LSR 3 SP1	TAP 1 INH	TXS 2 REL	AND 2 IMM	AND 2 DIR	AND 3 EXT	AND 4 IX2	AND 5 SP2	AND 3 IX1	AND 4 SP1		AND IX
5	BRCLR2 3 DIR	BCLR2 4 DIR	BCS 2 REL	STHX 3 DIR	LDHX 3 IMM	LDHX 3 IMM	LDHX 3 IMM	CPHX 3 IMM	CPHX 2 DIR	TPA 1 INH	TSX 1 INH	BIT 2 IMM	BIT 2 DIR	BIT 3 EXT	BIT 4 IX2	BIT 5 SP2	BIT 3 IX1	BIT 4 SP1		BIT IX
6	BRSET3 3 DIR	BSET3 4 DIR	BNE 2 REL	ROR 3 DIR	ROR 1 INH	ROR 1 INH	ROR 1 INH	ROR 2 IX+	ROR 3 SP1	PULA 2 INH		LDA 2 IMM	LDA 2 DIR	LDA 3 EXT	LDA 4 IX2	LDA 5 SP2	LDA 3 IX1	LDA 4 SP1		LDA IX
7	BRCLR3 3 DIR	BCLR3 4 DIR	BEO 2 REL	ASR 3 DIR	ASRX 1 INH	ASRX 1 INH	ASR 2 IX+	ASR 3 SP1	ASR 3 SP1	PSHA 2 INH	TAX 1 INH	AIS 2 IMM	STA 2 DIR	STA 3 EXT	STA 4 IX2	STA 5 SP2	STA 3 IX1	STA 4 SP1		STA IX
8	BRSET4 3 DIR	BSET4 4 DIR	BHCC 2 REL	LSL 3 DIR	LSL 1 INH	LSL 1 INH	LSL 2 IX+	LSL 3 SP1	LSL 3 SP1	PULX 2 INH	CLC 1 INH	EOR 2 IMM	EOR 2 DIR	EOR 3 EXT	EOR 4 IX2	EOR 5 SP2	EOR 3 IX1	EOR 4 SP1		EOR IX
9	BRCLR4 3 DIR	BCLR4 4 DIR	BHCS 2 REL	ROL 3 DIR	ROLY 1 INH	ROLY 1 INH	ROL 2 IX+	ROL 3 SP1	ROL 3 SP1	PSHX 2 INH	SEC 1 INH	ADC 2 IMM	ADC 2 DIR	ADC 3 EXT	ADC 4 IX2	ADC 5 SP2	ADC 3 IX1	ADC 4 SP1		ADC IX
A	BRSET5 3 DIR	BSET5 4 DIR	BPL 2 REL	DEC 3 DIR	DECX 1 INH	DECX 1 INH	DEC 2 IX+	DEC 3 SP1	DEC 3 SP1	PULH 2 INH	CLI 2 INH	ORA 2 IMM	ORA 2 DIR	ORA 3 EXT	ORA 4 IX2	ORA 5 SP2	ORA 3 IX1	ORA 4 SP1		ORA IX
B	BRCLR5 3 DIR	BCLR5 4 DIR	BMI 2 REL	DBNZ 3 DIR	DBNZX 2 INH	DBNZX 2 INH	DBNZ 3 IX+	DBNZ 4 SP1	DBNZ 4 SP1	PSHH 2 INH	SEI 2 INH	ADD 2 IMM	ADD 2 DIR	ADD 3 EXT	ADD 4 IX2	ADD 5 SP2	ADD 3 IX1	ADD 4 SP1		ADD IX
C	BRSET6 3 DIR	BSET6 4 DIR	BMC 2 REL	INC 3 DIR	INCA 1 INH	INCA 1 INH	INC 2 IX+	INC 3 SP1	INC 3 SP1	CLRH 1 INH	RSP 1 INH	JMP 2 IMM	JMP 2 DIR	JMP 3 EXT	JMP 4 IX2	JMP 5 SP2	JMP 3 IX1	JMP 4 SP1		JMP IX
D	BRCLR6 3 DIR	BCLR6 4 DIR	BMS 2 REL	TST 3 DIR	TSTA 1 INH	TSTA 1 INH	TST 2 IX+	TST 3 SP1	TST 3 SP1		NOP 1 INH	BSR 2 REL	JSR 2 DIR	JSR 3 EXT	JSR 4 IX2	JSR 5 SP2	JSR 3 IX1	JSR 4 SP1		JSR IX
E	BRSET7 3 DIR	BSET7 4 DIR	BIL 2 REL	MOV 3 DIR	MOV 4 DD	MOV 4 DD	MOV 4 IMD	MOV 4 SP1	MOV 4 SP1	STOP 1 INH		LDX 2 IMM	LDX 2 DIR	LDX 3 EXT	LDX 4 IX2	LDX 5 SP2	LDX 3 IX1	LDX 4 SP1		LDX IX
F	BRCLR7 3 DIR	BCLR7 4 DIR	BIH 2 REL	CLR 3 DIR	CLRX 1 INH	CLRX 1 INH	CLR 2 IX+	CLR 3 SP1	CLR 3 SP1	WAIT 1 INH	TXA 1 INH	AIX 2 IMM	STX 2 DIR	STX 3 EXT	STX 4 IX2	STX 5 SP2	STX 3 IX1	STX 4 SP1		STX IX

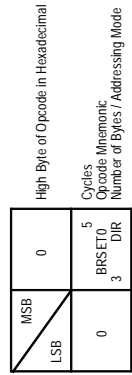

High Byte of Opcode in Hexadecimal
Cycles
Opcode Mnemonic
Number of Bytes / Addressing Mode

Low Byte of Opcode in Hexadecimal

SP1 Stack Pointer, 8-Bit Offset
SP2 Stack Pointer, 16-Bit Offset
IX+ Indexed, No Offset with Post-Increment
IX1+ Indexed, 1-Byte Offset with Post-Increment

REL Relative
IX Indexed, No Offset
IX1 Indexed, 8-Bit Offset
IX2 Indexed, 16-Bit Offset
IMD Immediate, Direct
DIR Direct
DIR+ Direct-Indexed
IX+D Indexed-Indexed
*Pre-byte for stack pointer indexed instructions

Section 9. System Integration Module (SIM)

9.1 Contents

9.2	Introduction	134
9.3	SIM Bus Clock Control and Generation	137
9.3.1	Bus Timing	137
9.3.2	Clock Startup from POR or LVI Reset	137
9.3.3	Clocks in Stop Mode and Wait Mode	138
9.4	Reset and System Initialization	138
9.4.1	External Pin Reset	139
9.4.2	Active Resets from Internal Sources	139
9.4.2.1	Power-On Reset (POR)	140
9.4.2.2	Computer Operating Properly (COP) Reset	141
9.4.2.3	Illegal Opcode Reset	141
9.4.2.4	Illegal Address Reset	141
9.4.2.5	Low-Voltage Inhibit (LVI) Reset	142
9.5	SIM Counter	142
9.5.1	SIM Counter During Power-On Reset	142
9.5.2	SIM Counter During Stop Mode Recovery	143
9.5.3	SIM Counter and Reset States	143
9.6	Program Exception Control	143
9.6.1	Interrupts	143
9.6.1.1	Hardware Interrupts	146
9.6.1.2	SWI Instruction	146
9.6.2	Reset	147
9.6.3	Break Interrupts	147
9.6.4	Status Flag Protection in Break Mode	147
9.7	Low-Power Modes	148
9.7.1	Wait Mode	148
9.7.2	Stop Mode	149

9.8	SIM Registers	151
9.8.1	SIM Break Status Register	151
9.8.2	SIM Reset Status Register	153
9.8.3	SIM Break Flag Control Register	154

9.2 Introduction

This section describes the system integration module (SIM), which supports up to 32 external and/or internal interrupts. Together with the central processor unit (CPU), the SIM controls all MCU activities. The SIM is a system state controller that coordinates CPU and exception timing. A block diagram of the SIM is shown in [Figure 9-1](#). [Figure 9-2](#) is a summary of the SIM input/output (I/O) registers.

The SIM is responsible for:

- Bus clock generation and control for CPU and peripherals:
 - Stop/wait/reset/break entry and recovery
 - Internal clock control
- Master reset control, including power-on reset (POR) and computer operating properly (COP) timeout
- Interrupt control:
 - Acknowledge timing
 - Arbitration control timing
 - Vector address generation
- CPU enable/disable timing
- Modular architecture expandable to 128 interrupt sources

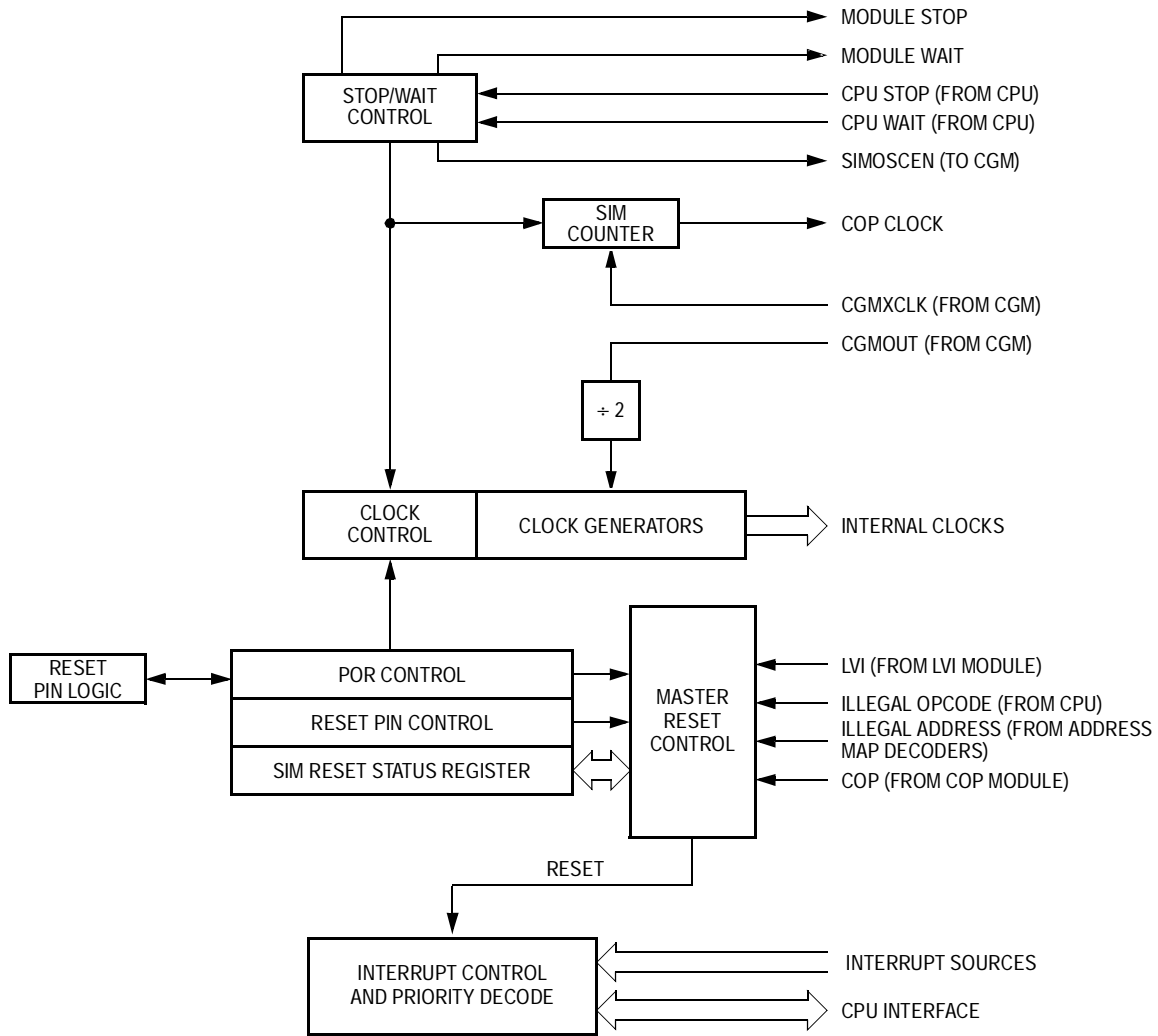

Figure 9-1. SIM Block Diagram

System Integration Module (SIM)

Addr.	Register Name	Bit 7	6	5	4	3	2	1	Bit 0	
\$FE00	SIM Break Status Register (SBSR) <i>See page 151.</i>	Read:	R	R	R	R	R	SBSW	R	
		Write:						See Note		
		Reset:	0							
\$FE01	SIM Reset Status Register (SRSR) <i>See page 153.</i>	Read:	POR	PIN	COP	ILOP	ILAD	0	LVI	0
		Write:								
		Reset:	1	0	0	0	0	0	0	0
\$FE03	SIM Break Flag Control Register (SBFCR) <i>See page 154.</i>	Read:	BCFE	R	R	R	R	R	R	R
		Write:								
		Reset:	0							

Note: Writing a logic 0 clears SBSW. = Unimplemented R = Reserved

Figure 9-2. SIM I/O Register Summary

Table 9-1 shows the internal signal names used in this section.

Table 9-1. Signal Name Conventions

Signal Name	Description
CGMXCLK	Buffered version of OSC1 from clock generator module (CGM)
CGMVCLK	PLL output
CGMOUT	PLL-based or OSC1-based clock output from clock generator module (CGM) Bus clock = CGMOUT divided by two
IAB	Internal address bus
IDB	Internal data bus
PORRST	Signal from the power-on reset (POR) module to the SIM
IRST	Internal reset signal
R/ \bar{W}	Read/write signal

9.3 SIM Bus Clock Control and Generation

The bus clock generator provides system clock signals for the CPU and peripherals on the MCU. The system clocks are generated from an incoming clock, CGMOUT, as shown in **Figure 9-3**. This clock can come from either an external oscillator or from the on-chip phase-locked loop (PLL). See **Section 10. Clock Generator Module (CGM)**.

9.3.1 Bus Timing

In user mode, the internal bus frequency is either the crystal oscillator output (CGMXCLK) divided by four or the PLL output (CGMVCLK) divided by four. See **Section 10. Clock Generator Module (CGM)**.

9.3.2 Clock Startup from POR or LVI Reset

When the power-on reset (POR) module or the low-voltage inhibit (LVI) module generates a reset, the clocks to the CPU and peripherals are inactive and held in an inactive phase until after 4096 CGMXCLK cycles. The \overline{RST} pin is driven low by the SIM during this entire period. The bus clocks start upon completion of the timeout.

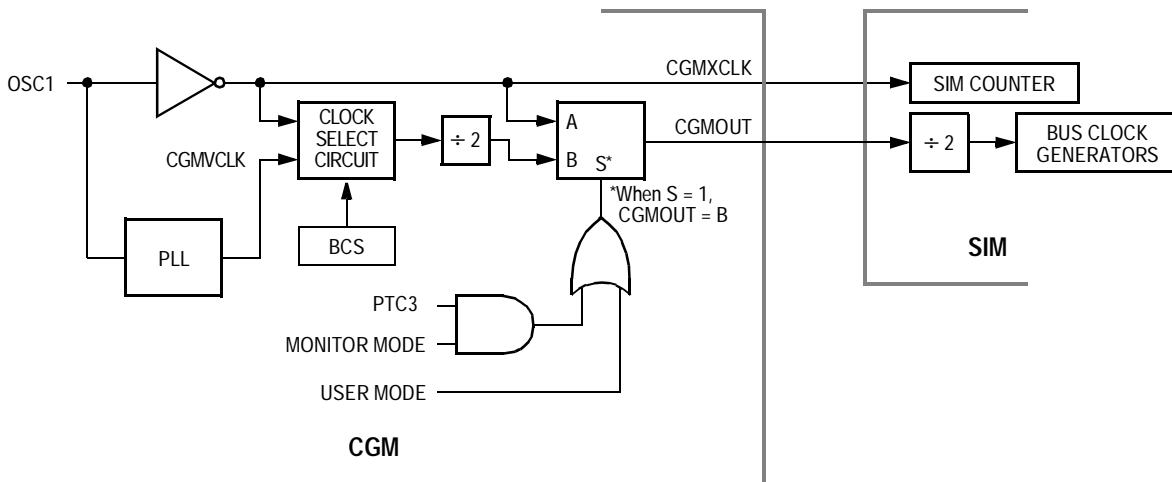

Figure 9-3. CGM Clock Signals

9.3.3 Clocks in Stop Mode and Wait Mode

Upon exit from stop mode by an interrupt, break, or reset, the SIM allows CGMXCLK to clock the SIM counter. The CPU and peripheral clocks do not become active until after the stop delay timeout. This timeout is selectable as 4096 or 32 CGMXCLK cycles. See [9.7.2 Stop Mode](#).

In wait mode, the CPU clocks are inactive. Refer to the wait mode subsection of each module to see if the module is active or inactive in wait mode. Some modules can be programmed to be active in wait mode.

9.4 Reset and System Initialization

The MCU has these reset sources:

- Power-on reset module (POR)
- External reset pin ($\overline{\text{RST}}$)
- Computer operating properly module (COP)
- Low-voltage inhibit module (LVI)
- Illegal opcode
- Illegal address

All of these resets produce the vector \$FFFE–FFFF (\$FEFE–FEFF in monitor mode) and assert the internal reset signal (IRST). IRST causes all registers to be returned to their default values and all modules to be returned to their reset states.

An internal reset clears the SIM counter (see [9.5 SIM Counter](#)), but an external reset does not. Each of the resets sets a corresponding bit in the SIM reset status register (SRSR). See [9.8 SIM Registers](#).

9.4.1 External Pin Reset

Pulling the asynchronous $\overline{\text{RST}}$ pin low halts all processing. The PIN bit of the SIM reset status register (SRSR) is set as long as $\overline{\text{RST}}$ is held low for a minimum of 67 CGMXCLK cycles, assuming that neither the POR nor the LVI was the source of the reset. See [Table 9-2](#) for details. [Figure 9-4](#) shows the relative timing.

Table 9-2. PIN Bit Set Timing

Reset Type	Number of Cycles Required to Set PIN
POR/LVI	4163 (4096 + 64 + 3)
All others	67 (64 + 3)

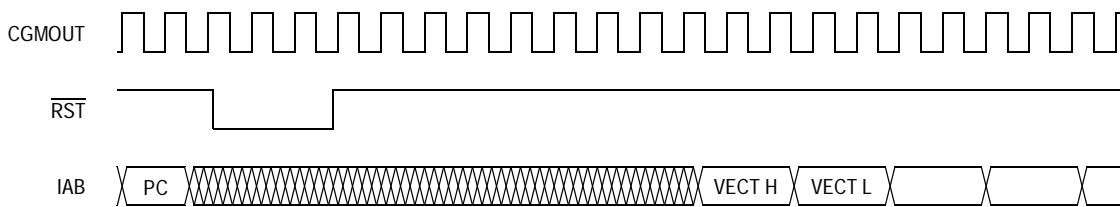

Figure 9-4. External Reset Timing

9.4.2 Active Resets from Internal Sources

All internal reset sources actively pull the $\overline{\text{RST}}$ pin low for 32 CGMXCLK cycles to allow resetting of external peripherals. The internal reset signal IRST continues to be asserted for an additional 32 cycles. See [Figure 9-5](#). An internal reset can be caused by an illegal address, illegal opcode, COP timeout, LVI, or POR. See [Figure 9-6](#). Note that for LVI or POR resets, the SIM cycles through 4096 CGMXCLK cycles during which the SIM forces the $\overline{\text{RST}}$ pin low. The internal reset signal then follows the sequence from the falling edge of $\overline{\text{RST}}$ shown in [Figure 9-5](#).

The COP reset is asynchronous to the bus clock.

The active reset feature allows the part to issue a reset to peripherals and other chips within a system built around the MCU.

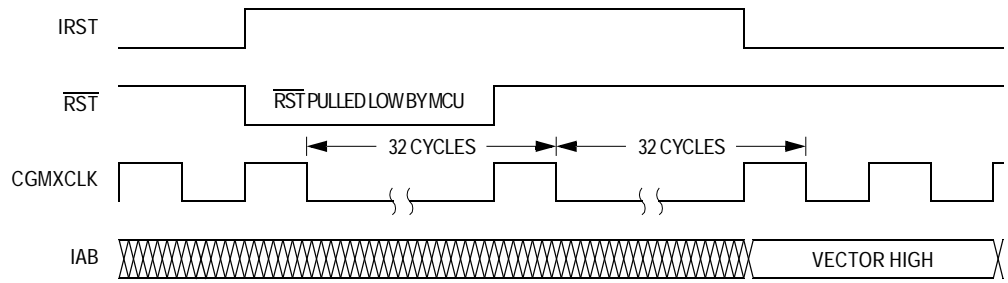

Figure 9-5. Internal Reset Timing

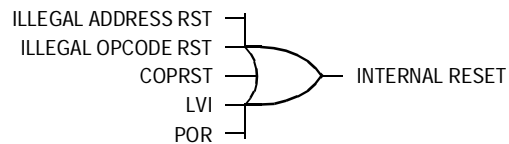

Figure 9-6. Sources of Internal Reset

9.4.2.1 Power-On Reset (POR)

When power is first applied to the MCU, the POR generates a pulse to indicate that power-on has occurred. The external reset pin ($\overline{\text{RST}}$) is held low while the SIM counter counts out 4096 CGMXCLK cycles. Another 64 CGMXCLK cycles later, the CPU and memories are released from reset to allow the reset vector sequence to occur.

At power-on, these events occur:

- A POR pulse is generated.
- The internal reset signal is asserted.
- The SIM enables CGMOUT .
- Internal clocks to the CPU and modules are held inactive for 4096 CGMXCLK cycles to allow stabilization of the oscillator.
- The $\overline{\text{RST}}$ pin is driven low during the oscillator stabilization time.
- The POR bit of the SIM reset status register (SRSR) is set and all other bits in the register are cleared.

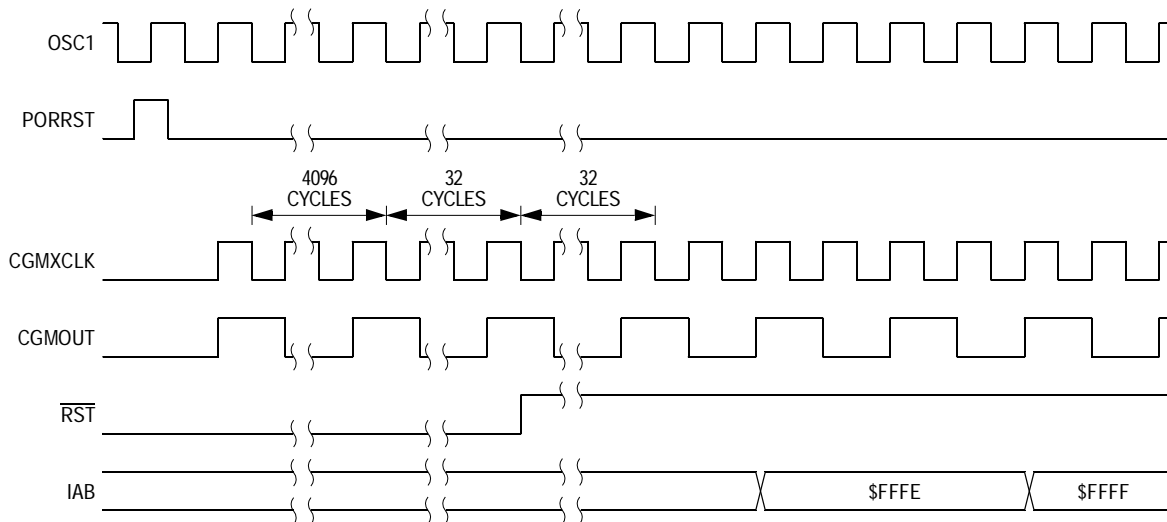

Figure 9-7. POR Recovery

9.4.2.2 Computer Operating Properly (COP) Reset

The overflow of the COP counter causes an internal reset and sets the COP bit in the SIM reset status register (SRSR) if the COPD bit in the CONFIG-1 register is at logic 0. See [Section 14. Computer Operating Properly \(COP\) Module](#).

9.4.2.3 Illegal Opcode Reset

The SIM decodes signals from the CPU to detect illegal instructions. An illegal instruction sets the ILOP bit in the SIM reset status register (SRSR) and causes a reset.

If the stop enable bit, STOP, in the CONFIG-1 register is logic 0, the SIM treats the STOP instruction as an illegal opcode and causes an illegal opcode reset.

9.4.2.4 Illegal Address Reset

An opcode fetch from an unmapped address generates an illegal address reset. The SIM verifies that the CPU is fetching an opcode prior to asserting the ILAD bit in the SIM reset status register (SRSR) and resetting the MCU. A data fetch from an unmapped address using

indexed addressing and PUL/PSH instructions will also generate an illegal address reset.

WARNING: *Extra care should be exercised when using this emulator part for development of code to be run in ROM-based M68HC08AS Family parts with a smaller memory size since some legal addresses will become illegal addresses on the smaller ROM memory map device and may, as a result, generate unwanted resets.*

9.4.2.5 Low-Voltage Inhibit (LVI) Reset

The low-voltage inhibit (LVI) module asserts its output to the SIM when the V_{DD} voltage falls to the V_{LVIL} voltage. The LVI bit in the SIM reset status register (SRSR) is set and a chip reset is asserted if the LVIPWRD and LVIRSTD bits in the CONFIG-1 register are at logic 0. The \overline{RST} pin will be held low until the SIM counts 4096 CGMXCLK cycles after V_{DD} rises above V_{LVIR} . Another 64 CGMXCLK cycles later, the CPU is released from reset to allow the reset vector sequence to occur. See [Section 15. Low-Voltage Inhibit \(LVI\) Module](#).

9.5 SIM Counter

The SIM counter is used by the power-on reset module (POR) and in stop mode recovery to allow the oscillator time to stabilize before enabling the internal bus (IBUS) clocks. The SIM counter also serves as a prescaler for the computer operating properly module (COP). The SIM counter overflow supplies the clock for the COP module. The SIM counter is 12 bits long and is clocked by the falling edge of CGMXCLK.

9.5.1 SIM Counter During Power-On Reset

The POR detects power applied to the MCU. At power-on, the POR circuit asserts the signal PORRST. Once the SIM is initialized, it enables the clock generation module (CGM) to drive the bus clock state machine.

9.5.2 SIM Counter During Stop Mode Recovery

The SIM counter also is used for stop mode recovery. The STOP instruction clears the SIM counter. After an interrupt, break, or reset, the SIM senses the state of the short stop recovery bit, SSREC, in the CONFIG-1 register. If the SSREC bit is a logic 1, then the stop recovery is reduced from the normal delay of 4096 CGMXCLK cycles down to 32 CGMXCLK cycles. This is ideal for applications using canned oscillators that do not require long startup times from stop mode. External crystal applications should use the full stop recovery time, that is, with SSREC cleared.

9.5.3 SIM Counter and Reset States

External reset has no effect on the SIM counter (see [9.7.2 Stop Mode](#) for details). The SIM counter is free-running after all reset states. See [9.4.2 Active Resets from Internal Sources](#) for counter control and internal reset recovery sequences.

9.6 Program Exception Control

Normal, sequential program execution can be changed in three different ways:

1. Interrupts:
 - a. Maskable hardware CPU interrupts
 - b. Non-maskable software interrupt instruction (SWI)
2. Reset
3. Break interrupts

9.6.1 Interrupts

At the beginning of an interrupt, the CPU saves the CPU register contents on the stack and sets the interrupt mask (I bit) to prevent additional interrupts. At the end of an interrupt, the RTI instruction recovers the CPU register contents from the stack so that normal processing can resume. [Figure 9-8](#) shows interrupt entry timing. [Figure 9-9](#) shows interrupt recovery timing.

System Integration Module (SIM)

Interrupts are latched, and arbitration is performed in the SIM at the start of interrupt processing. The arbitration result is a constant that the CPU uses to determine which vector to fetch. Once an interrupt is latched by the SIM, no other interrupt can take precedence, regardless of priority, until the latched interrupt is serviced (or the I bit is cleared).

See [Figure 9-10](#).

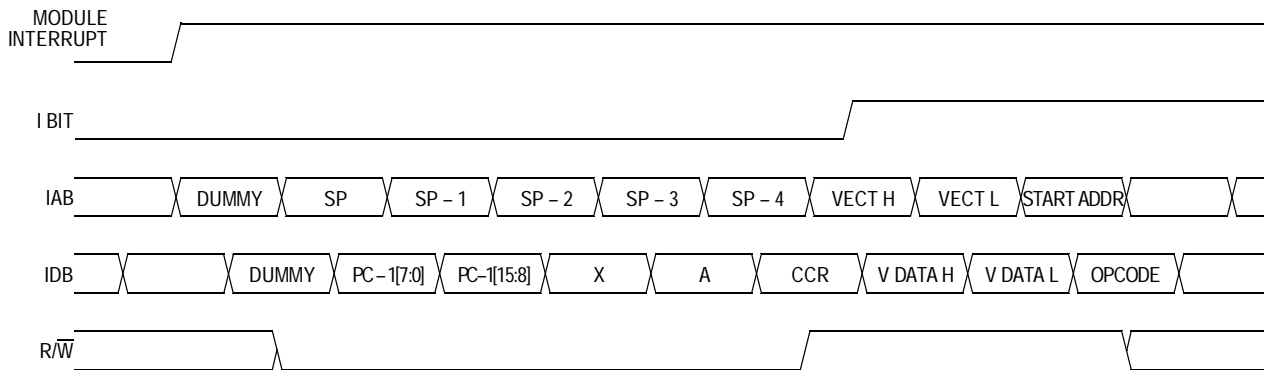

Figure 9-8. Interrupt Entry

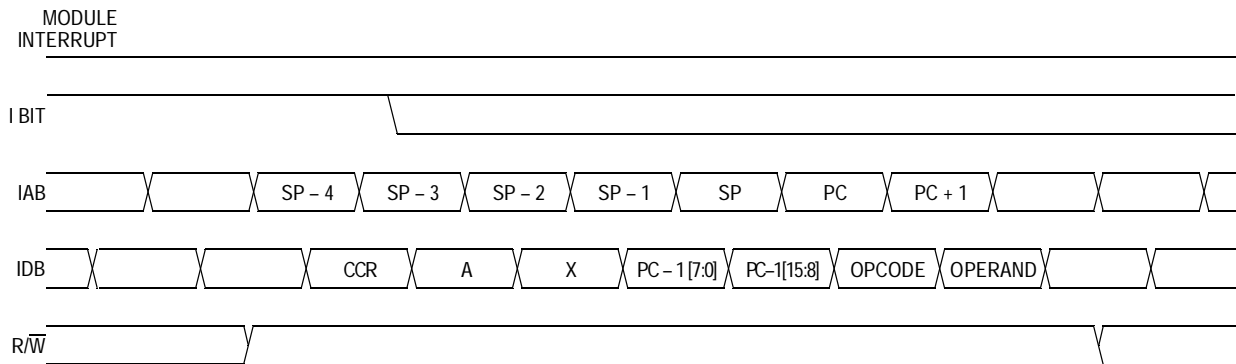

Figure 9-9. Interrupt Recovery

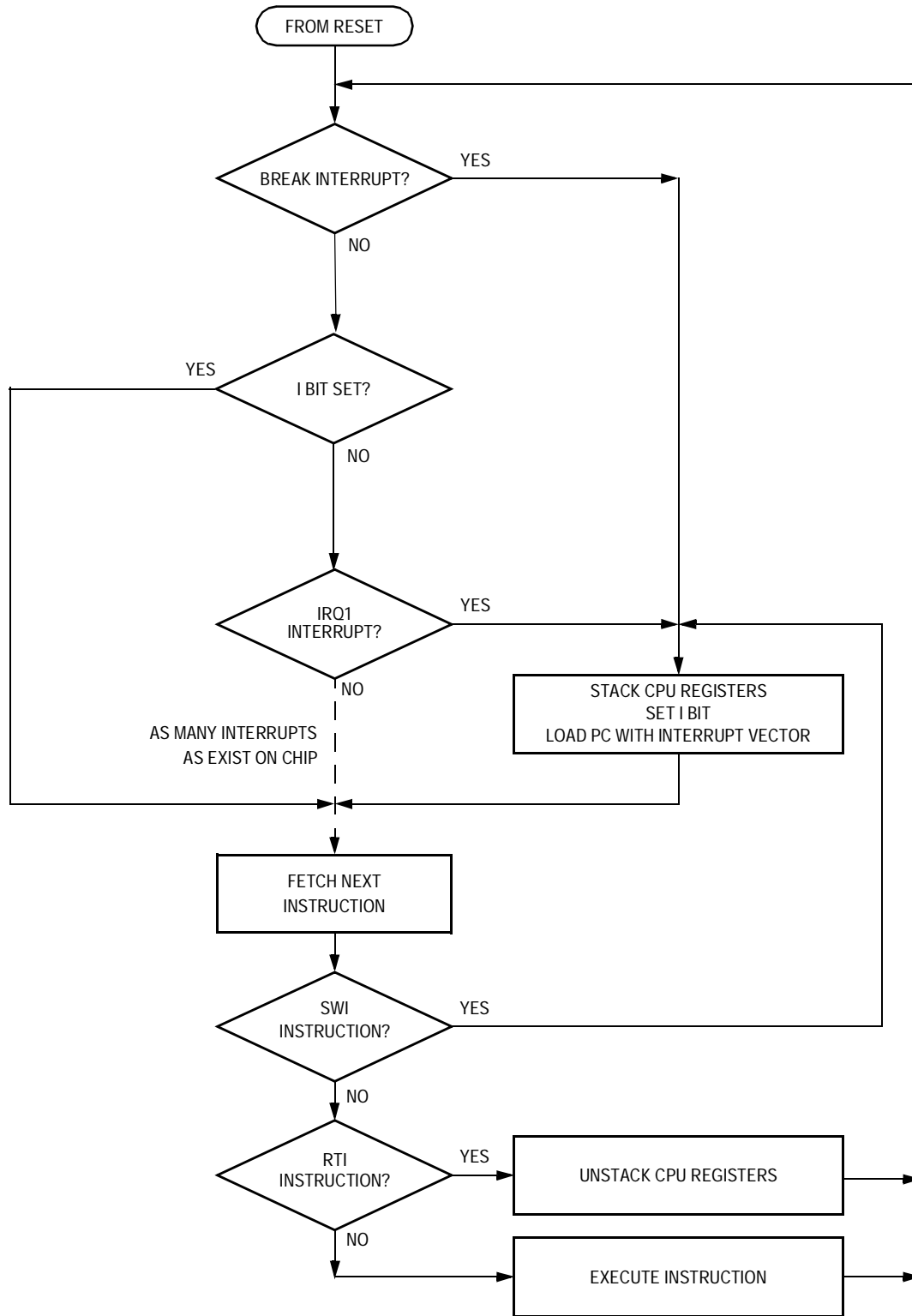

Figure 9-10. Interrupt Processing

9.6.1.1 Hardware Interrupts

A hardware interrupt does not stop the current instruction. Processing of a hardware interrupt begins after completion of the current instruction. When the current instruction is complete, the SIM checks all pending hardware interrupts. If interrupts are not masked (I bit clear in the condition code register), and if the corresponding interrupt enable bit is set, the SIM proceeds with interrupt processing; otherwise, the next instruction is fetched and executed.

If more than one interrupt is pending at the end of an instruction execution, the highest priority interrupt is serviced first. **Figure 9-11** demonstrates what happens when two interrupts are pending. If an interrupt is pending upon exit from the original interrupt service routine, the pending interrupt is serviced before the LDA instruction is executed.

The LDA opcode is prefetched by both the INT1 and INT2 RTI instructions. However, in the case of the INT1 RTI prefetch, this is a redundant operation.

NOTE: *To maintain compatibility with the M6805, M146805, and M68HC05 Families, the H register is not pushed on the stack during interrupt entry. If the interrupt service routine modifies the H register or uses the indexed addressing mode, software should save the H register and then restore it prior to exiting the routine.*

9.6.1.2 SWI Instruction

The SWI instruction is a non-maskable instruction that causes an interrupt regardless of the state of the interrupt mask (I bit) in the condition code register.

NOTE: *A software interrupt pushes PC onto the stack. A software interrupt does **not** push PC – 1, as a hardware interrupt does.*

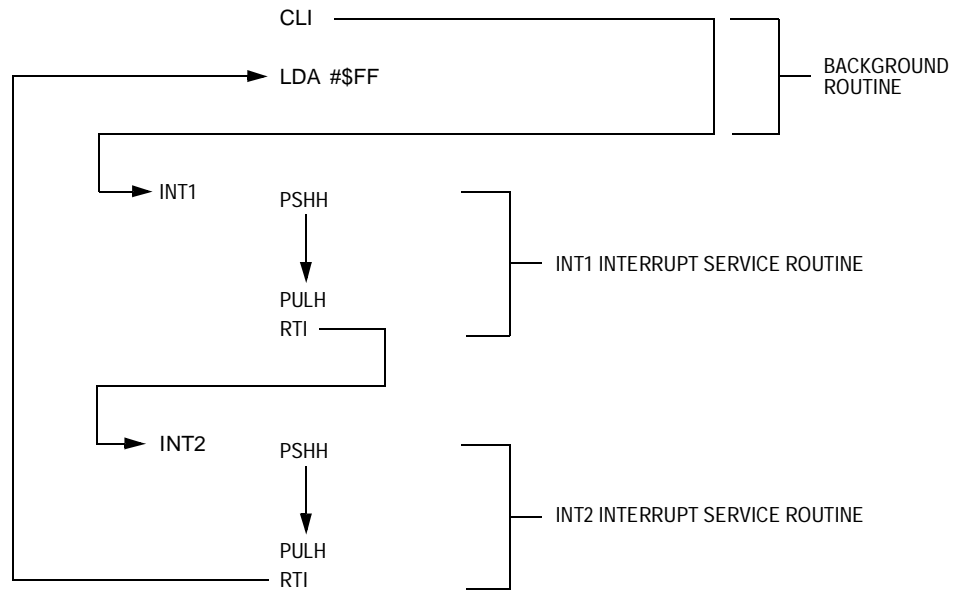

Figure 9-11. Interrupt Recognition Example

9.6.2 Reset

All reset sources always have higher priority than interrupts and cannot be arbitrated.

9.6.3 Break Interrupts

The break module can stop normal program flow at a software-programmable break point by asserting its break interrupt output. See [Section 12. Break Module](#). The SIM puts the CPU into the break state by forcing it to the SWI vector location. Refer to the break interrupt subsection of each module to see how each module is affected by the break state.

9.6.4 Status Flag Protection in Break Mode

The SIM controls whether status flags contained in other modules can be cleared during break mode. The user can select whether flags are protected from being cleared by properly initializing the break clear flag enable bit (BCFE) in the SIM break flag control register (SBFCR).

Protecting flags in break mode ensures that set flags will not be cleared while in break mode. This protection allows registers to be freely read and written during break mode without losing status flag information.

Setting the BCFE bit enables the clearing mechanisms. Once cleared in break mode, a flag remains cleared even when break mode is exited. Status flags with a 2-step clearing mechanism — for example, a read of one register followed by the read or write of another — are protected, even when the first step is accomplished prior to entering break mode. Upon leaving break mode, execution of the second step will clear the flag as normal.

9.7 Low-Power Modes

Executing the WAIT or STOP instruction puts the MCU in a low power-consumption mode for standby situations. The SIM holds the CPU in a non-clocked state. The operation of each of these modes is described in this section. Both STOP and WAIT clear the interrupt mask (I) in the condition code register, allowing interrupts to occur.

9.7.1 Wait Mode

In wait mode, the CPU clocks are inactive while one set of peripheral clocks continues to run. [Figure 9-12](#) shows the timing for wait mode entry.

A module that is active during wait mode can wake up the CPU with an interrupt if the interrupt is enabled. Stacking for the interrupt begins one cycle after the WAIT instruction during which the interrupt occurred. Refer to the wait mode subsection of each module to see if the module is active or inactive in wait mode. Some modules can be programmed to be active in wait mode.

Wait mode can also be exited by a reset or break. A break interrupt during wait mode sets the SIM break stop/wait bit, SBSW, in the SIM break status register (SBSR). If the COP disable bit, COPD, in the configuration register is logic 0, then the computer operating properly module (COP) is enabled and remains active in wait mode.

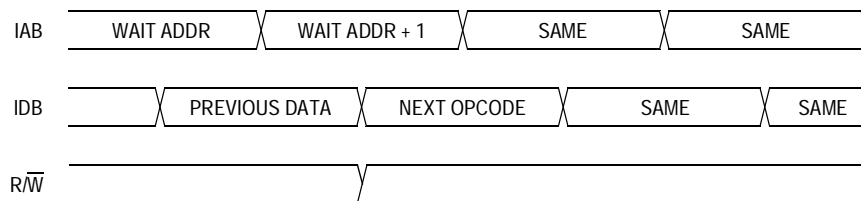

Note: Previous data can be operand data or the WAIT opcode, depending on the last instruction.

Figure 9-12. Wait Mode Entry Timing

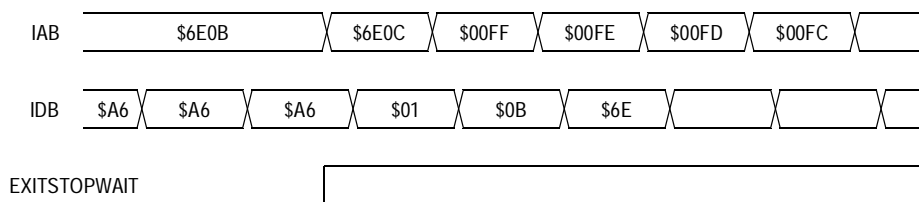

Note: EXITSTOPWAIT = $\overline{\text{RST}}$ pin or CPU interrupt OR break interrupt

Figure 9-13. Wait Recovery from Interrupt or Break

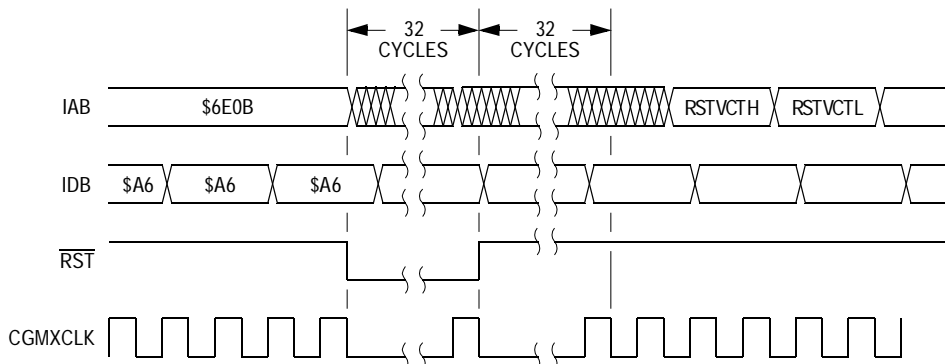

Figure 9-14. Wait Recovery from Internal Reset

9.7.2 Stop Mode

In stop mode, the SIM counter is reset and the system clocks are disabled. An interrupt request from a module can cause an exit from stop mode. Stacking for interrupts begins after the selected stop recovery time has elapsed. Reset or break also causes an exit from stop mode.

System Integration Module (SIM)

The SIM disables the clock generator module outputs (CGMOUT and CGMXCLK) in stop mode, stopping the CPU and peripherals. Stop recovery time is selectable using the SSREC bit in the configuration register (CONFIG-1). If SSREC is set, stop recovery is reduced from the normal delay of 4096 CGMXCLK cycles down to 32. This is ideal for applications using canned oscillators that do not require long startup times from stop mode.

NOTE: External crystal applications should use the full stop recovery time by clearing the SSREC bit.

A break interrupt during stop mode sets the SIM break stop/wait bit (SBSW) in the SIM break status register (SBSR).

The SIM counter is held in reset from the execution of the STOP instruction until the beginning of stop recovery. It is then used to time the recovery period. Figure 9-15 shows stop mode entry timing.

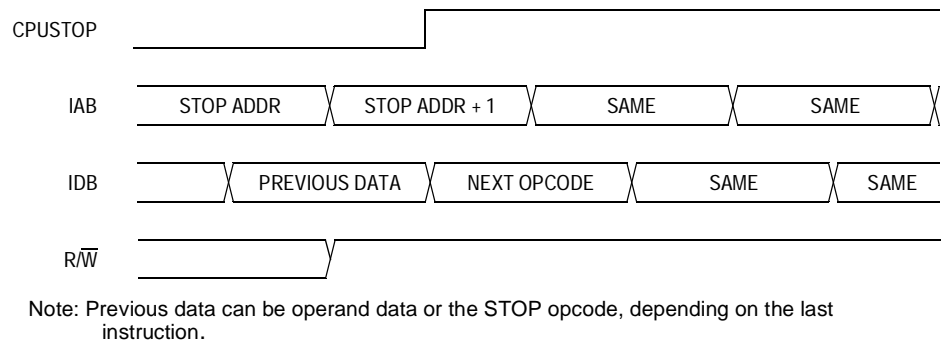

Figure 9-15. Stop Mode Entry Timing

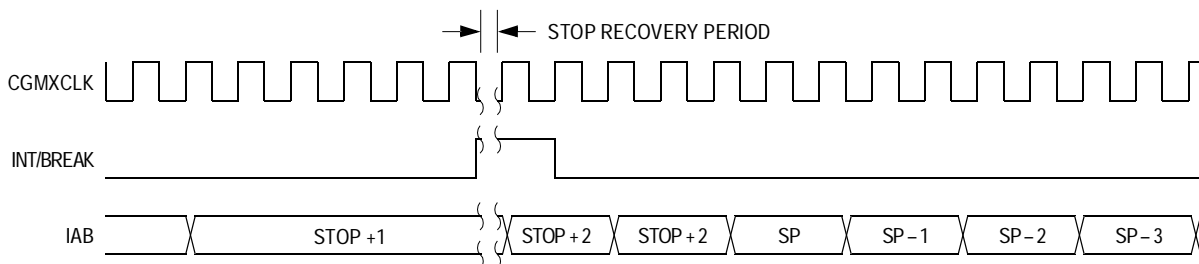

Figure 9-16. Stop Mode Recovery from Interrupt or Break

9.8 SIM Registers

The SIM has three memory mapped registers:

- Break status register, SBSR
- Reset status register, SRSR
- Break flag control register, SBFCR

9.8.1 SIM Break Status Register

The SIM break status register contains a flag to indicate that a break caused an exit from stop or wait mode.

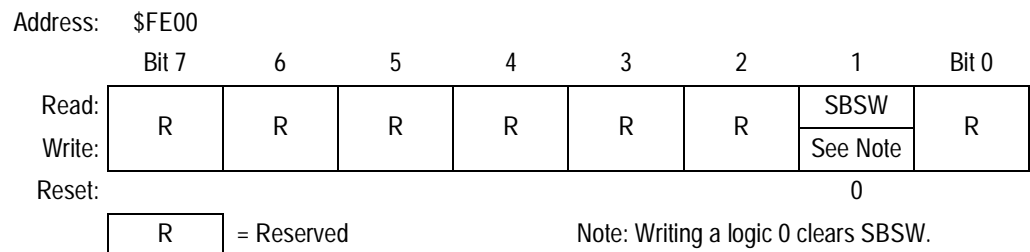

Figure 9-17. SIM Break Status Register (SBSR)

SBSW — SIM Break Stop/Wait

This status bit is useful in applications requiring a return to wait or stop mode after exiting from a break interrupt. Clear SBSW by writing a logic 0 to it. Reset clears SBSW.

1 = Stop mode or wait mode was exited by break interrupt

0 = Stop mode or wait mode was not exited by break interrupt

SBSW can be read within the break state SWI routine. The user can modify the return address on the stack by subtracting one from it. The code given here is an example of this. Writing 0 to the SBSW bit clears it.

System Integration Module (SIM)

```
; This code works if the H register has been pushed onto the stack in the break
; service routine software. This code should be executed at the end of the
; break service routine software.
```

```
HIBYTE EQU 5
```

```
LOBYTE EQU 6
```

```
; If not SBSW, do RTI
```

```
BRCLR SBSW,SBSR, RETURN ; See if wait mode or stop mode was exited
; by break.
```

```
TST LOBYTE,SP ; If RETURNLO is not zero,
```

```
BNE DOLO ; then just decrement low byte.
```

```
DEC HIBYTE,SP ; Else deal with high byte, too.
```

```
DOLO DEC LOBYTE,SP ; Point to WAIT/STOP opcode.
```

```
RETURN PULH ; Restore H register.
RTI
```

9.8.2 SIM Reset Status Register

This register contains six flags that show the source of the last reset. The status register will automatically clear after reading it. A power-on reset sets the POR bit and clears all other bits in the register.

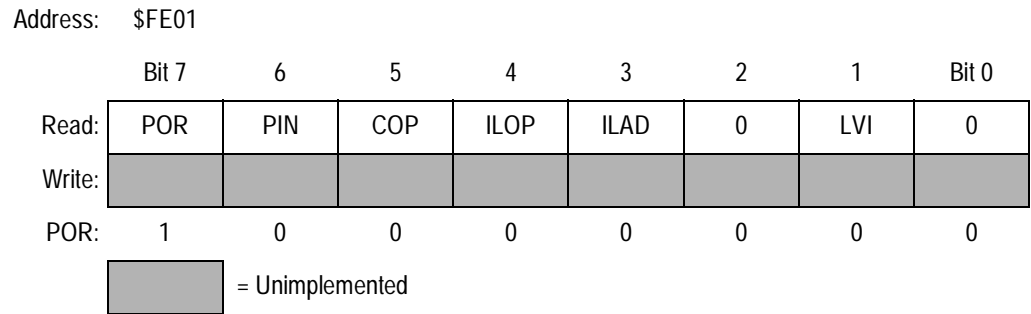

Figure 9-18. SIM Reset Status Register (SRSR)

POR — Power-On Reset Bit

- 1 = Last reset caused by POR circuit
- 0 = Read of SRSR

PIN — External Reset Bit

- 1 = Last reset caused by external reset pin (\overline{RST})
- 0 = POR or read of SRSR

COP — Computer Operating Properly Reset Bit

- 1 = Last reset caused by COP counter
- 0 = POR or read of SRSR

ILOP — Illegal Opcode Reset Bit

- 1 = Last reset caused by an illegal opcode
- 0 = POR or read of SRSR

ILAD — Illegal Address Reset Bit (opcode fetches only)

- 1 = Last reset caused by an opcode fetch from an illegal address
- 0 = POR or read of SRSR

LVI — Low-Voltage Inhibit Reset Bit

- 1 = Last reset was caused by the LVI circuit
- 0 = POR or read of SRSR

9.8.3 SIM Break Flag Control Register

The SIM break control register contains a bit that enables software to clear status bits while the MCU is in a break state.

Address: \$FE03

	Bit 7	6	5	4	3	2	1	Bit 0
Read:	BCFE	R	R	R	R	R	R	R
Write:								

Reset: 0

R

 = Reserved

Figure 9-19. SIM Break Flag Control Register (SBFCR)

BCFE — Break Clear Flag Enable Bit

This read/write bit enables software to clear status bits by accessing status registers while the MCU is in a break state. To clear status bits during the break state, the BCFE bit must be set.

1 = Status bits clearable during break

0 = Status bits not clearable during break

Section 10. Clock Generator Module (CGM)

10.1 Contents

10.2	Introduction	156
10.3	Features	156
10.4	Functional Description	157
10.4.1	Crystal Oscillator Circuit	157
10.4.2	Phase-Locked Loop Circuit (PLL)	159
10.4.2.1	Circuits	159
10.4.2.2	Acquisition and Tracking Modes	161
10.4.2.3	Manual and Automatic PLL Bandwidth Modes	161
10.4.2.4	Programming the PLL	163
10.4.2.5	Special Programming Exceptions	165
10.4.3	Base Clock Selector Circuit	165
10.4.4	CGM External Connections	166
10.5	I/O Signals	167
10.5.1	Crystal Amplifier Input Pin (OSC1)	167
10.5.2	Crystal Amplifier Output Pin (OSC2)	167
10.5.3	External Filter Capacitor Pin (CGMXFC)	167
10.5.4	Analog Power Pin (V_{DDA})	168
10.5.5	Oscillator Enable Signal (SIMOSCEN)	168
10.5.6	Crystal Output Frequency Signal (CGMXCLK)	168
10.5.7	CGM Base Clock Output (CGMOUT)	168
10.5.8	CGM CPU Interrupt (CGMINT)	168
10.6	CGM Registers	169
10.6.1	PLL Control Register	169
10.6.2	PLL Bandwidth Control Register	171
10.6.3	PLL Programming Register	173
10.7	Interrupts	174

10.8	Low-Power Modes	175
10.8.1	Wait Mode	175
10.8.2	Stop Mode	175
10.9	CGM During Break Interrupts	175
10.10	Acquisition/Lock Time Specifications	176
10.10.1	Acquisition/Lock Time Definitions	176
10.10.2	Parametric Influences on Reaction Time	177
10.10.3	Choosing a Filter Capacitor	178

10.2 Introduction

The clock generator module (CGM) generates the crystal clock signal, CGMXCLK, which operates at the frequency of the crystal. The CGM also generates the base clock signal, CGMOUT, from which the system clocks are derived. CGMOUT is based on either the crystal clock divided by two or the phase-locked loop (PLL) clock, CGMVCLK, divided by two. The PLL is a frequency generator designed for use with 1-MHz to 8-MHz crystals or ceramic resonators. The PLL can generate an 8-MHz bus frequency without using a 32-MHz crystal.

10.3 Features

Features of the CGM include:

- Phase-locked loop with output frequency in integer multiples of the crystal reference
- Programmable hardware voltage-controlled oscillator (VCO) for low-jitter operation
- Automatic bandwidth control mode for low-jitter operation
- Automatic frequency lock detector
- CPU interrupt on entry or exit from locked condition

10.4 Functional Description

The CGM consists of three major submodules:

1. Crystal oscillator circuit — The crystal oscillator circuit generates the constant crystal frequency clock, CGMXCLK.
2. Phase-locked loop (PLL) — The PLL generates the programmable VCO frequency clock CGMVCLK.
3. Base clock selector circuit — This software-controlled circuit selects either CGMXCLK divided by two or the VCO clock, CGMVCLK, divided by two as the base clock, CGMOUT. The system clocks are derived from CGMOUT.

Figure 10-1 shows the structure of the CGM.

10.4.1 Crystal Oscillator Circuit

The crystal oscillator circuit consists of an inverting amplifier and an external crystal. The OSC1 pin is the input to the amplifier and the OSC2 pin is the output. The SIMOSCEN signal enables the crystal oscillator circuit.

The CGMXCLK signal is the output of the crystal oscillator circuit and runs at a rate equal to the crystal frequency. CGMXCLK is then buffered to produce CGMRCLK, the PLL reference clock.

CGMXCLK can be used by other modules which require precise timing for operation. The duty cycle of CGMXCLK is not guaranteed to be 50 percent and depends on external factors, including the crystal and related external components.

An externally generated clock also can feed the OSC1 pin of the crystal oscillator circuit. Connect the external clock to the OSC1 pin and let the OSC2 pin float.

Clock Generator Module (CGM)

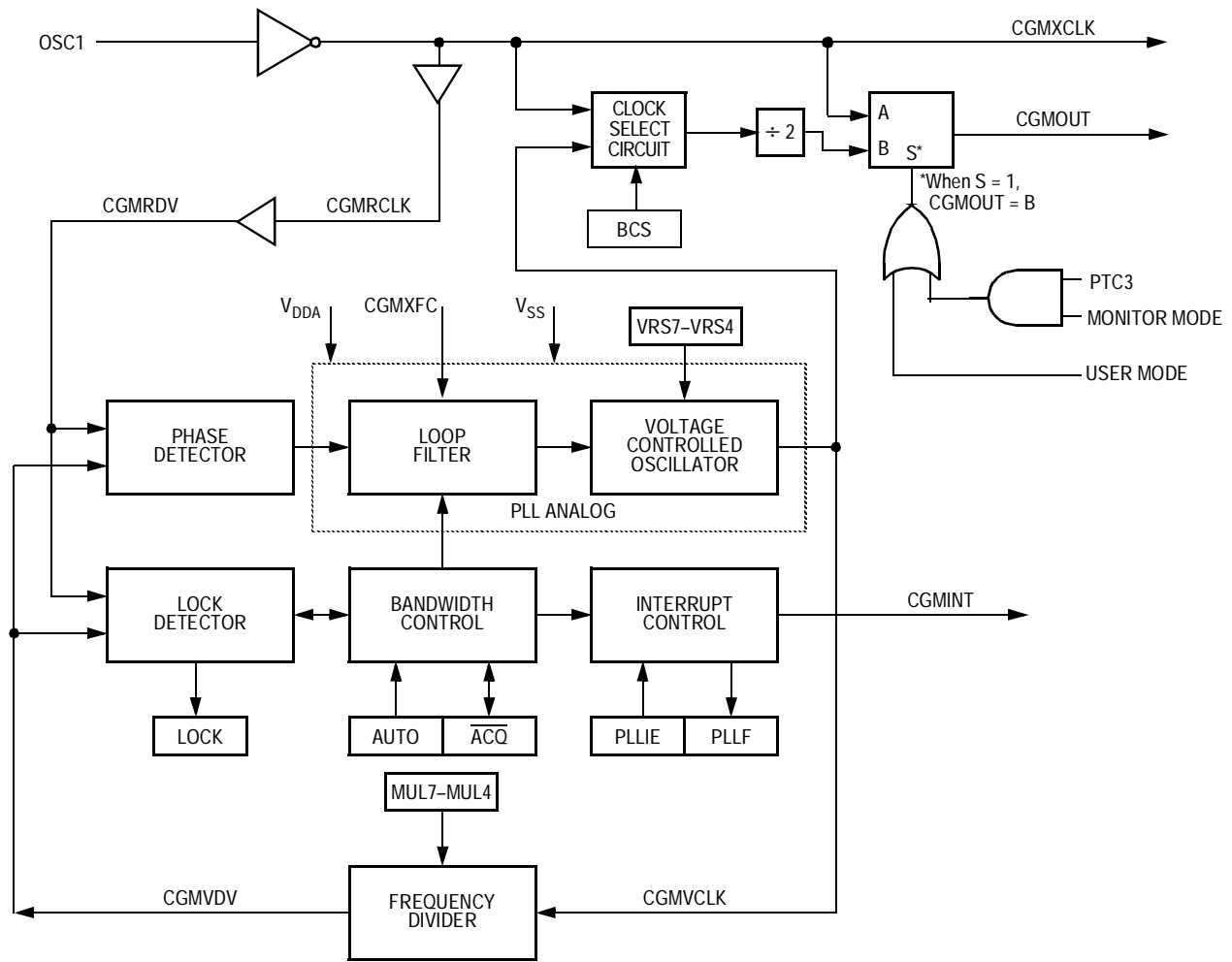

Figure 10-1. CGM Block Diagram

Freescale Semiconductor, Inc.

Addr.	Register Name	Bit 7	6	5	4	3	2	1	Bit 0	
\$001C	PLL Control Register (PCTL) See page 169.	Read:	PLLIE	PLL F	PLLON	BCS	1	1	1	1
		Write:								
		Reset:	0	0	1	0	1	1	1	1
\$001D	PLL Bandwidth Control Register (PBWC) See page 171.	Read:	AUTO	LOCK	\overline{ACQ}	XLD	0	0	0	0
		Write:								
		Reset:	0	0	0	0	0	0	0	0
\$001E	PLL Programming Register (PPG) See page 173.	Read:	MUL7	MUL6	MUL5	MUL4	VRS7	VRS6	VRS5	VRS4
		Write:								
		Reset:	0	1	1	0	0	1	1	0

 = Unimplemented

Figure 10-2. I/O Register Summary

10.4.2 Phase-Locked Loop Circuit (PLL)

The PLL is a frequency generator that can operate in either acquisition mode or tracking mode, depending on the accuracy of the output frequency. The PLL can change between acquisition and tracking modes either automatically or manually.

10.4.2.1 Circuits

The PLL consists of these circuits:

- Voltage-controlled oscillator (VCO)
- Modulo VCO frequency divider
- Phase detector
- Loop filter
- Lock detector

The operating range of the VCO is programmable for a wide range of frequencies and for maximum immunity to external noise, including supply and CGMXFC noise. The VCO frequency is bound to a range from roughly one-half to twice the center-of-range frequency, f_{VRS} . Modulating the voltage on the CGMXFC pin changes the frequency within this range. By design, f_{VRS} is equal to the nominal center-of-range frequency, f_{NOM} , (4.9152 MHz) times a linear factor L or $(L)f_{NOM}$.

CGMRCLK is the PLL reference clock, a buffered version of CGMXCLK. CGMRCLK runs at a frequency, f_{RCLK} , and is fed to the PLL through a buffer. The buffer output is the final reference clock, CGMRDV, running at a frequency $f_{RDV} = f_{RCLK}$.

The VCO's output clock, CGMVCLK, running at a frequency f_{VCLK} , is fed back through a programmable modulo divider. The modulo divider reduces the VCO clock by a factor, N . The divider's output is the VCO feedback clock, CGMVDV, running at a frequency $f_{VDV} = f_{VCLK}/N$. See [10.4.2.4 Programming the PLL](#) for more information.

The phase detector then compares the VCO feedback clock, CGMVDV, with the final reference clock, CGMRDV. A correction pulse is generated based on the phase difference between the two signals. The loop filter then slightly alters the dc voltage on the external capacitor connected to CGMXFC based on the width and direction of the correction pulse. The filter can make fast or slow corrections depending on its mode, as described in [10.4.2.2 Acquisition and Tracking Modes](#). The value of the external capacitor and the reference frequency determines the speed of the corrections and the stability of the PLL.

The lock detector compares the frequencies of the VCO feedback clock, CGMVDV, and the final reference clock, CGMRDV. Therefore, the speed of the lock detector is directly proportional to the final reference frequency, f_{RDV} . The circuit determines the mode of the PLL and the lock condition based on this comparison.

10.4.2.2 Acquisition and Tracking Modes

The PLL filter is manually or automatically configurable into one of two operating modes:

1. Acquisition mode — In acquisition mode, the filter can make large frequency corrections to the VCO. This mode is used at PLL startup or when the PLL has suffered a severe noise hit and the VCO frequency is far off the desired frequency. When in acquisition mode, the $\overline{\text{ACQ}}$ bit is clear in the PLL bandwidth control register. See [10.6.2 PLL Bandwidth Control Register](#).
2. Tracking mode — In tracking mode, the filter makes only small corrections to the frequency of the VCO. PLL jitter is much lower in tracking mode, but the response to noise is also slower. The PLL enters tracking mode when the VCO frequency is nearly correct, such as when the PLL is selected as the base clock source. See [10.4.3 Base Clock Selector Circuit](#). The PLL is automatically in tracking mode when it's not in acquisition mode or when the $\overline{\text{ACQ}}$ bit is set.

10.4.2.3 Manual and Automatic PLL Bandwidth Modes

The PLL can change the bandwidth or operational mode of the loop filter manually or automatically.

In automatic bandwidth control mode (AUTO = 1), the lock detector automatically switches between acquisition and tracking modes. Automatic bandwidth control mode also is used to determine when the VCO clock, CGMVCLK, is safe to use as the source for the base clock, CGMOUT. See [10.6.2 PLL Bandwidth Control Register](#). If PLL CPU interrupt requests are enabled, the software can wait for a PLL CPU interrupt request and then check the LOCK bit. If CPU interrupts are disabled, software can poll the LOCK bit continuously (during PLL startup, usually) or at periodic intervals. In either case, when the LOCK bit is set, the VCO clock is safe to use as the source for the base clock. See [10.4.3 Base Clock Selector Circuit](#). If the VCO is selected as the source for the base clock and the LOCK bit is clear, the PLL has suffered a severe noise hit and the software must take appropriate action, depending on the application. See [10.7 Interrupts](#).

These conditions apply when the PLL is in automatic bandwidth control mode:

- The $\overline{\text{ACQ}}$ bit (see [10.6.2 PLL Bandwidth Control Register](#)) is a read-only indicator of the mode of the filter. See [10.4.2.2 Acquisition and Tracking Modes](#).
- The $\overline{\text{ACQ}}$ bit is set when the VCO frequency is within a certain tolerance, Δ_{TRK} , and is cleared when the VCO frequency is out of a certain tolerance, Δ_{UNT} . See [24.2 Maximum Ratings](#).
- The LOCK bit is a read-only indicator of the locked state of the PLL.
- The LOCK bit is set when the VCO frequency is within a certain tolerance, Δ_{Lock} , and is cleared when the VCO frequency is out of a certain tolerance, Δ_{unl} . See [24.2 Maximum Ratings](#).
- CPU interrupts can occur if enabled ($\text{PLLIE} = 1$) when the PLL's lock condition changes, toggling the LOCK bit. See [10.6.1 PLL Control Register](#).

The PLL also can operate in manual mode ($\text{AUTO} = 0$). Manual mode is used by systems that do not require an indicator of the lock condition for proper operation. Such systems typically operate well below f_{BUSMAX} and require fast startup.

These conditions apply when in manual mode:

- $\overline{\text{ACQ}}$ is a writable control bit that controls the mode of the filter. Before turning on the PLL in manual mode, the $\overline{\text{ACQ}}$ bit must be clear.
- Before entering tracking mode ($\overline{\text{ACQ}} = 1$), software must wait a given time, t_{acq} (see [24.2 Maximum Ratings](#)), after turning on the PLL by setting PLLON in the PLL control register (PCTL).
- Software must wait a given time, t_{AL} , after entering tracking mode before selecting the PLL as the clock source to CGMOUT ($\text{BCS} = 1$).
- The LOCK bit is disabled.
- CPU interrupts from the CGM are disabled.

10.4.2.4 Programming the PLL

Use this 9-step procedure to program the PLL. **Table 10-1** lists the variables used and their meaning.

Table 10-1. Variable Definitions

Variable	Definition
f_{BUSDES}	Desired bus clock frequency
f_{VCLKDES}	Desired VCO clock frequency
f_{RCLK}	Chosen reference crystal frequency
f_{VCLK}	Calculated VCO clock frequency
f_{BUS}	Calculated bus clock frequency
f_{NOM}	Nominal VCO center frequency
f_{VRS}	Shifted VCO center frequency

1. Choose the desired bus frequency, f_{BUSDES} .
Example: $f_{\text{BUSDES}} = 8 \text{ MHz}$
2. Calculate the desired VCO frequency, f_{VCLKDES} .
 $f_{\text{VCLKDES}} = 4 \times f_{\text{BUSDES}}$
Example: $f_{\text{VCLKDES}} = 4 \times 8 \text{ MHz} = 32 \text{ MHz}$
3. Using a reference frequency, f_{RCLK} , equal to the crystal frequency, calculate the VCO frequency multiplier, N. Round the result to the nearest integer.

$$N = \frac{f_{\text{VCLKDES}}}{f_{\text{RCLK}}}$$

$$\text{Example: } N = \frac{32 \text{ MHz}}{4 \text{ MHz}} = 8$$

4. Calculate the VCO frequency, f_{VCLK} .

$$f_{\text{VCLK}} = N \times f_{\text{RCLK}}$$

$$\text{Example: } f_{\text{VCLK}} = 8 \times 4 \text{ MHz} = 32 \text{ MHz}$$

Clock Generator Module (CGM)

Freescale Semiconductor, Inc.

5. Calculate the bus frequency, f_{BUS} , and compare f_{BUS} with f_{BUSDES} .

$$f_{BUS} = \frac{f_{VCLK}}{4}$$

Example: $f_{BUS} = \frac{32 \text{ MHz}}{4} = 8 \text{ MHz}$

6. If the calculated f_{BUS} is not within the tolerance limits of the application, select another f_{BUSDES} or another f_{RCLK} .
7. Using the value 4.9152 MHz for f_{NOM} , calculate the VCO linear range multiplier, L. The linear range multiplier controls the frequency range of the PLL.

$$L = \text{round}\left(\frac{f_{VCLK}}{f_{NOM}}\right)$$

Example: $L = \frac{32 \text{ MHz}}{4.9152 \text{ MHz}} = 7$

8. Calculate the VCO center-of-range frequency, f_{VRS} . The center-of-range frequency is the midpoint between the minimum and maximum frequencies attainable by the PLL.

$$f_{VRS} = L \times f_{NOM}$$

Example: $f_{VRS} = 7 \times 4.9152 \text{ MHz} = 34.4 \text{ MHz}$

NOTE: For proper operation, $f_{VRS} - f_{VCLK} \leq \frac{f_{NOM}}{2}$.

Exceeding the recommended maximum bus frequency or VCO frequency can crash the MCU.

9. Program the PLL registers accordingly:
 - a. In the upper four bits of the PLL programming register (PPG), program the binary equivalent of N.
 - b. In the lower four bits of the PLL programming register (PPG), program the binary equivalent of L.

10.4.2.5 Special Programming Exceptions

The programming method, described in [10.4.2.4 Programming the PLL](#), does not account for two possible exceptions. A value of 0 for N or L is meaningless when used in the equations given. To account for these exceptions:

- A 0 value for N is interpreted the same as a value of 1.
- A 0 value for L disables the PLL and prevents its selection as the source for the base clock. See [10.4.3 Base Clock Selector Circuit](#).

10.4.3 Base Clock Selector Circuit

This circuit is used to select either the crystal clock, CGMXCLK, or the VCO clock, CGMVCLK, as the source of the base clock, CGMOUT. The two input clocks go through a transition control circuit that waits up to three CGMXCLK cycles and three CGMVCLK cycles to change from one clock source to the other. During this time, CGMOUT is held in stasis. The output of the transition control circuit is then divided by two to correct the duty cycle. Therefore, the bus clock frequency, which is one-half of the base clock frequency, is one-fourth the frequency of the selected clock (CGMXCLK or CGMVCLK).

The BCS bit in the PLL control register (PCTL) selects which clock drives CGMOUT. The VCO clock cannot be selected as the base clock source if the PLL is not turned on. The PLL cannot be turned off if the VCO clock is selected. The PLL cannot be turned on or off simultaneously with the selection or deselection of the VCO clock. The VCO clock also cannot be selected as the base clock source if the factor L is programmed to a 0. This value would set up a condition inconsistent with the operation of the PLL, so that the PLL would be disabled and the crystal clock would be forced as the source of the base clock.

10.4.4 CGM External Connections

In its typical configuration, the CGM requires seven external components. Five of these are for the crystal oscillator and two are for the PLL.

The crystal oscillator is normally connected in a Pierce oscillator configuration, as shown in [Figure 10-3](#). [Figure 10-3](#) shows only the logical representation of the internal components and may not represent actual circuitry. The oscillator configuration uses five components:

1. Crystal, X_1
2. Fixed capacitor, C_1
3. Tuning capacitor, C_2 (can also be a fixed capacitor)
4. Feedback resistor, R_B
5. Series resistor, R_S (optional)

The series resistor (R_S) may not be required for all ranges of operation, especially with high-frequency crystals. Refer to the crystal manufacturer's data for more information.

[Figure 10-3](#) also shows the external components for the PLL:

1. Bypass capacitor, C_{BYP}
2. Filter capacitor, C_F

Routing should be done with great care to minimize signal cross talk and noise. See [10.10 Acquisition/Lock Time Specifications](#) for routing information and more information on the filter capacitor's value and its effects on PLL performance.

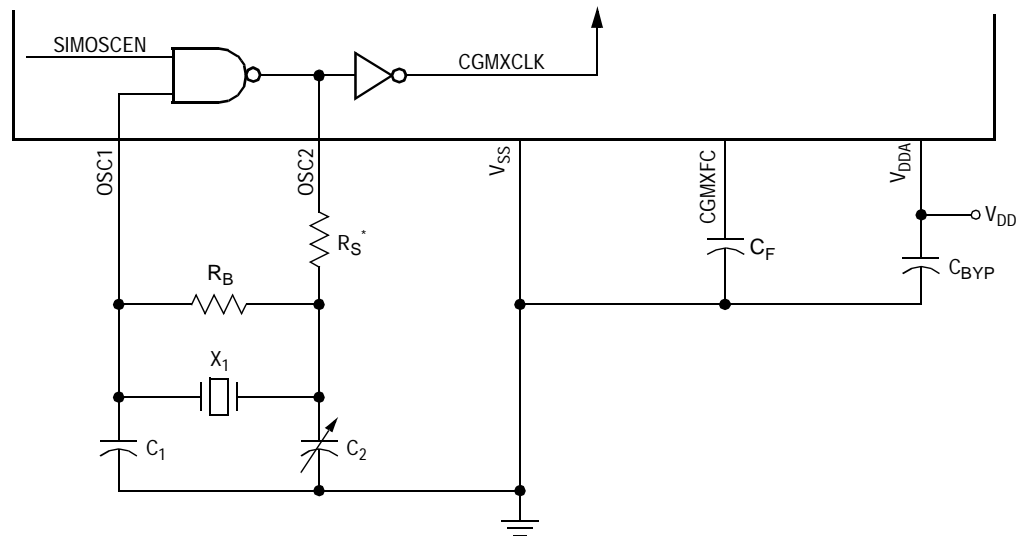

* R_S can be 0 (shorted) when used with higher-frequency crystals. Refer to manufacturer's data.

Figure 10-3. CGM External Connections

10.5 I/O Signals

The following paragraphs describe the CGM input/output (I/O) signals.

10.5.1 Crystal Amplifier Input Pin (OSC1)

The OSC1 pin is an input to the crystal oscillator amplifier.

10.5.2 Crystal Amplifier Output Pin (OSC2)

The OSC2 pin is the output of the crystal oscillator inverting amplifier.

10.5.3 External Filter Capacitor Pin (CGMXFC)

The CGMXFC pin is required by the loop filter to filter out phase corrections. A small external capacitor is connected to this pin.

NOTE: To prevent noise problems, C_F should be placed as close to the CGMXFC pin as possible with minimum routing distances and no routing of other signals across the C_F connection.

Clock Generator Module (CGM)

10.5.4 Analog Power Pin (V_{DDA})

V_{DDA} is a power pin used by the analog portions of the PLL. Connect the V_{DDA} pin to the same voltage potential as the V_{DD} pin.

NOTE: Route V_{DDA} carefully for maximum noise immunity and place bypass capacitors as close as possible to the package.

10.5.5 Oscillator Enable Signal (SIMOSCEN)

The SIMOSCEN signal enables the oscillator and PLL.

10.5.6 Crystal Output Frequency Signal (CGMXCLK)

CGMXCLK is the crystal oscillator output signal. It runs at the full speed of the crystal (f_{XCLK}) and comes directly from the crystal oscillator circuit. **Figure 10-3** shows only the logical relation of CGMXCLK to OSC1 and OSC2 and may not represent the actual circuitry. The duty cycle of CGMXCLK is unknown and may depend on the crystal and other external factors. Also, the frequency and amplitude of CGMXCLK can be unstable at startup.

10.5.7 CGM Base Clock Output (CGMOUT)

CGMOUT is the clock output of the CGM. This signal is used to generate the MCU clocks. CGMOUT is a 50 percent duty cycle clock running at twice the bus frequency. CGMOUT is software programmable to be either the oscillator output, CGMXCLK, divided by two or the VCO clock, CGMVCLK, divided by two.

10.5.8 CGM CPU Interrupt (CGMINT)

CGMINT is the CPU interrupt signal generated by the PLL lock detector.

10.6 CGM Registers

Three registers control and monitor operation of the CGM:

1. PLL control register (PCTL)
2. PLL bandwidth control register (PBWC)
3. PLL programming register (PPG)

10.6.1 PLL Control Register

The PLL control register (PCTL) contains the interrupt enable and flag bits, the on/off switch, and the base clock selector bit.

Address: \$001C

	Bit 7	6	5	4	3	2	1	Bit 0
Read:	PLLIE	PLLIF	PLLON	BCS	1	1	1	1
Write:								
Reset:	0	0	1	0	1	1	1	1

 = Unimplemented

Figure 10-4. PLL Control Register (PCTL)

PLLIE — PLL Interrupt Enable Bit

This read/write bit enables the PLL to generate a CPU interrupt request when the LOCK bit toggles, setting the PLL flag, PLLIF. When the AUTO bit in the PLL bandwidth control register (PBWC) is clear, PLLIE cannot be written and reads as logic 0. Reset clears the PLLIE bit.

- 1 = PLL CPU interrupt requests enabled
- 0 = PLL CPU interrupt requests disabled

PLLIF — PLL Flag Bit

This read-only bit is set whenever the LOCK bit toggles. PLLIF generates a CPU interrupt request if the PLLIE bit also is set. PLLIF always reads as logic 0 when the AUTO bit in the PLL bandwidth control register (PBWC) is clear. Clear the PLLIF bit by reading the PLL control register. Reset clears the PLLIF bit.

- 1 = Change in lock condition
- 0 = No change in lock condition

Clock Generator Module (CGM)

NOTE: Do not inadvertently clear the PLLF bit. Be aware that any read or read-modify-write operation on the PLL control register clears the PLLF bit.

PLLON — PLL On Bit

This read/write bit activates the PLL and enables the VCO clock, CGMVCLK. PLLON cannot be cleared if the VCO clock is driving the base clock, CGMOUT (BCS = 1). See [10.4.3 Base Clock Selector Circuit](#). Reset sets this bit so that the loop can stabilize as the MCU is powering up.

1 = PLL on

0 = PLL off

BCS — Base Clock Select Bit

This read/write bit selects either the crystal oscillator output, CGMXCLK, or the VCO clock, CGMVCLK, as the source of the CGM output, CGMOUT. CGMOUT frequency is one-half the frequency of the selected clock. BCS cannot be set while the PLLON bit is clear. After toggling BCS, it may take up to three CGMXCLK and three CGMVCLK cycles to complete the transition from one source clock to the other. During the transition, CGMOUT is held in stasis. See [10.4.3 Base Clock Selector Circuit](#). Reset and the STOP instruction clear the BCS bit.

1 = CGMVCLK divided by two drives CGMOUT.

0 = CGMXCLK divided by two drives CGMOUT.

NOTE: PLLON and BCS have built-in protection that prevents the base clock selector circuit from selecting the VCO clock as the source of the base clock if the PLL is off. Therefore, PLLON cannot be cleared when BCS is set, and BCS cannot be set when PLLON is clear. If the PLL is off (PLLON = 0), selecting CGMVCLK requires two writes to the PLL control register. See [10.4.3 Base Clock Selector Circuit](#).

PCTL3–PCTL0 — Unimplemented

These bits provide no function and always read as logic 1s.

10.6.2 PLL Bandwidth Control Register

The PLL bandwidth control register (PBWC):

- Selects automatic or manual (software-controlled) bandwidth control mode
- Indicates when the PLL is locked
- In automatic bandwidth control mode, indicates when the PLL is in acquisition or tracking mode
- In manual operation, forces the PLL into acquisition or tracking mode

Address: \$001D

	Bit 7	6	5	4	3	2	1	Bit 0
Read:	AUTO	LOCK	\overline{ACQ}	XLD	0	0	0	0
Write:								
Reset:	0	0	0	0	0	0	0	0

 = Unimplemented

Figure 10-5. PLL Bandwidth Control Register (PBWC)

AUTO — Automatic Bandwidth Control Bit

This read/write bit selects automatic or manual bandwidth control. When initializing the PLL for manual operation (AUTO = 0), clear the \overline{ACQ} bit before turning on the PLL. Reset clears the AUTO bit.

- 1 = Automatic bandwidth control
- 0 = Manual bandwidth control

LOCK — Lock Indicator Bit

When the AUTO bit is set, LOCK is a read-only bit that becomes set when the VCO clock, CGMVCLK, is locked (running at the programmed frequency). When the AUTO bit is clear, LOCK reads as logic 0 and has no meaning. Reset clears the LOCK bit.

- 1 = VCO frequency correct or locked
- 0 = VCO frequency incorrect or unlocked

\overline{ACQ} — Acquisition Mode Bit

When the AUTO bit is set, \overline{ACQ} is a read-only bit that indicates whether the PLL is in acquisition mode or tracking mode. When the AUTO bit is clear, \overline{ACQ} is a read/write bit that controls whether the PLL is in acquisition or tracking mode.

In automatic bandwidth control mode (AUTO = 1), the last-written value from manual operation is stored in a temporary location and is recovered when manual operation resumes. Reset clears this bit, enabling acquisition mode.

- 1 = Tracking mode
- 0 = Acquisition mode

XLD — Crystal Loss Detect Bit

When the VCO output, CGMVCLK, is driving CGMOUT, this read/write bit can indicate whether the crystal reference frequency is active or not.

- 1 = Crystal reference not active
- 0 = Crystal reference active

To check the status of the crystal reference:

1. Write a logic 1 to XLD.
2. Wait $N \times 4$ cycles. N is the VCO frequency multiplier.
3. Read XLD.

The crystal loss detect function works only when the BCS bit is set, selecting CGMVCLK to drive CGMOUT. When BCS is clear, XLD always reads as logic 0.

Bits 3–0 — Reserved for Test

These bits enable test functions not available in user mode. To ensure software portability from development systems to user applications, software should write 0s to bits 3–0 when writing to PBWC.

10.6.3 PLL Programming Register

The PLL programming register (PPG) contains the programming information for the modulo feedback divider and the programming information for the hardware configuration of the VCO.

Address: \$001E

	Bit 7	6	5	4	3	2	1	Bit 0
Read:	MUL7	MUL6	MUL5	MUL4	VRS7	VRS6	VRS5	VRS4
Write:								
Reset:	0	1	1	0	0	1	1	0

Figure 10-6. PLL Programming Register (PPG)

MUL7–MUL4 — Multiplier Select Bits

These read/write bits control the modulo feedback divider that selects the VCO frequency multiplier, N. (See [10.4.2.1 Circuits](#) and [10.4.2.4 Programming the PLL](#).) A value of \$0 in the multiplier select bits configures the modulo feedback divider the same as a value of \$1. Reset initializes these bits to \$6 to give a default multiply value of 6.

Table 10-2. VCO Frequency Multiplier (N) Selection

MUL7:MUL6:MUL5:MUL4	VCO Frequency Multiplier (N)
0000	1
0001	1
0010	2
0011	3
↓	↓
1101	13
1110	14
1111	15

NOTE: The multiplier select bits have built-in protection that prevents them from being written when the PLL is on (PLLON = 1).

VRS7–VRS4 — VCO Range Select Bits

These read/write bits control the hardware center-of-range linear multiplier L, which controls the hardware center-of-range frequency, f_{VRS} . (See [10.4.2.1 Circuits](#), [10.4.2.4 Programming the PLL](#), and [10.6.1 PLL Control Register](#).) VRS7–VRS4 cannot be written when the PLLON bit in the PLL control register (PCTL) is set. See [10.4.2.5 Special Programming Exceptions](#). A value of \$0 in the VCO range select bits disables the PLL and clears the BCS bit in the PCTL. (See [10.4.3 Base Clock Selector Circuit](#) and [10.4.2.5 Special Programming Exceptions](#) for more information.) Reset initializes the bits to \$6 to give a default range multiply value of 6.

NOTE: *The VCO range select bits have built-in protection that prevents them from being written when the PLL is on (PLLON = 1) and prevents selection of the VCO clock as the source of the base clock (BCS = 1) if the VCO range select bits are all clear.*

The VCO range select bits must be programmed correctly. Incorrect programming can result in failure of the PLL to achieve lock.

10.7 Interrupts

When the AUTO bit is set in the PLL bandwidth control register (PBWC), the PLL can generate a CPU interrupt request every time the LOCK bit changes state. The PLLIE bit in the PLL control register (PCTL) enables CPU interrupt requests from the PLL. PLLF, the interrupt flag in the PCTL, becomes set whether CPU interrupt requests are enabled or not. When the AUTO bit is clear, CPU interrupt requests from the PLL are disabled and PLLF reads as logic 0.

Software should read the LOCK bit after a PLL CPU interrupt request to see if the request was due to an entry into lock or an exit from lock. When the PLL enters lock, the VCO clock, CGMVCLK, divided by two can be selected as the CGMOUT source by setting BCS in the PCTL. When the PLL exits lock, the VCO clock frequency is corrupt, and appropriate precautions should be taken. If the application is not frequency sensitive, CPU interrupt requests should be disabled to prevent PLL interrupt

service routines from impeding software performance or from exceeding stack limitations.

NOTE: *Software can select the CGMVCLK divided by two as the CGMOUT source even if the PLL is not locked (LOCK = 0). Therefore, software should make sure the PLL is locked before setting the BCS bit.*

10.8 Low-Power Modes

The WAIT and STOP instructions put the MCU in low power-consumption standby modes.

10.8.1 Wait Mode

The CGM remains active in wait mode. Before entering wait mode, software can disengage and turn off the PLL by clearing the BCS and PLLON bits in the PLL control register (PCTL). Less power-sensitive applications can disengage the PLL without turning it off. Applications that require the PLL to wake the MCU from wait mode also can deselect the PLL output without turning off the PLL.

10.8.2 Stop Mode

The STOP instruction disables the CGM and holds low all CGM outputs (CGMXCLK, CGMOUT, and CGMINT).

If CGMOUT is being driven by CGMVCLK and a STOP instruction is executed, the PLL will clear the BCS bit in the PLL control register, causing CGMOUT to be driven by CGMXCLK. When the MCU recovers from STOP, the crystal clock divided by two drives CGMOUT and BCS remains clear.

10.9 CGM During Break Interrupts

The BCFE bit in the break flag control register (BFCR) enables software to clear status bits during the break state. See [Section 12. Break Module](#).

To allow software to clear status bits during a break interrupt, write a logic 1 to the BCFE bit. If a status bit is cleared during the break state, it remains cleared when the MCU exits the break state.

To protect the PLLF bit during the break state, write a logic 0 to the BCFE bit. With BCFE at logic 0 (its default state), software can read and write the PLL control register during the break state without affecting the PLLF bit.

10.10 Acquisition/Lock Time Specifications

The acquisition and lock times of the PLL are, in many applications, the most critical PLL design parameters. Proper design and use of the PLL ensures the highest stability and lowest acquisition/lock times.

10.10.1 Acquisition/Lock Time Definitions

Typical control systems refer to the acquisition time or lock time as the reaction time, within specified tolerances, of the system to a step input. In a PLL, the step input occurs when the PLL is turned on or when it suffers a noise hit. The tolerance is usually specified as a percent of the step input or when the output settles to the desired value plus or minus a percent of the frequency change. Therefore, the reaction time is constant in this definition, regardless of the size of the step input. For example, consider a system with a 5 percent acquisition time tolerance. If a command instructs the system to change from 0 Hz to 1 MHz, the acquisition time is the time taken for the frequency to reach 1 MHz \pm 50 kHz. Fifty kHz = 5 percent of the 1-MHz step input. If the system is operating at 1 MHz and suffers a -100 kHz noise hit, the acquisition time is the time taken to return from 900 kHz to 1 MHz \pm 5 kHz. Five kHz = 5 percent of the 100-kHz step input.

Other systems refer to acquisition and lock times as the time the system takes to reduce the error between the actual output and the desired output to within specified tolerances. Therefore, the acquisition or lock time varies according to the original error in the output. Minor errors may not even be registered. Typical PLL applications prefer to use this definition because the system requires the output frequency to be within

a certain tolerance of the desired frequency regardless of the size of the initial error.

The discrepancy in these definitions makes it difficult to specify an acquisition or lock time for a typical PLL. Therefore, the definitions for acquisition and lock times for this module are:

- Acquisition time, t_{ACQ} , is the time the PLL takes to reduce the error between the actual output frequency and the desired output frequency to less than the tracking mode entry tolerance, Δ_{trk} . Acquisition time is based on an initial frequency error, $(f_{DES} - f_{ORIG})/f_{DES}$, of not more than ± 100 percent. In automatic bandwidth control mode (see [10.4.2.3 Manual and Automatic PLL Bandwidth Modes](#)), acquisition time expires when the \overline{ACQ} bit becomes set in the PLL bandwidth control register (PBWC).
- Lock time, t_{LOCK} , is the time the PLL takes to reduce the error between the actual output frequency and the desired output frequency to less than the lock mode entry tolerance, Δ_{LOCK} . Lock time is based on an initial frequency error, $(f_{DES} - f_{ORIG})/f_{DES}$, of not more than ± 100 percent. In automatic bandwidth control mode, lock time expires when the LOCK bit becomes set in the PLL bandwidth control register (PBWC). See [10.4.2.3 Manual and Automatic PLL Bandwidth Modes](#).

Obviously, the acquisition and lock times can vary according to how large the frequency error is and may be shorter or longer in many cases.

10.10.2 Parametric Influences on Reaction Time

Acquisition and lock times are designed to be as short as possible while still providing the highest possible stability. These reaction times are not constant, however. Many factors directly and indirectly affect the acquisition time.

The most critical parameter which affects the reaction times of the PLL is the reference frequency, f_{RDV} . This frequency is the input to the phase detector and controls how often the PLL makes corrections. For stability, the corrections must be small compared to the desired frequency, so several corrections are required to reduce the frequency error.

Therefore, the slower the reference the longer it takes to make these corrections. This parameter is also under user control via the choice of crystal frequency f_{XCLK} .

Another critical parameter is the external filter capacitor. The PLL modifies the voltage on the VCO by adding or subtracting charge from this capacitor. Therefore, the rate at which the voltage changes for a given frequency error (thus a change in charge) is proportional to the capacitor size. The size of the capacitor also is related to the stability of the PLL. If the capacitor is too small, the PLL cannot make small enough adjustments to the voltage and the system cannot lock. If the capacitor is too large, the PLL may not be able to adjust the voltage in a reasonable time. See [10.10.3 Choosing a Filter Capacitor](#).

Also important is the operating voltage potential applied to V_{DDA} . The power supply potential alters the characteristics of the PLL. A fixed value is best. Variable supplies, such as batteries, are acceptable if they vary within a known range at very slow speeds. Noise on the power supply is not acceptable, because it causes small frequency errors which continually change the acquisition time of the PLL.

Temperature and processing also can affect acquisition time because the electrical characteristics of the PLL change. The part operates as specified as long as these influences stay within the specified limits. External factors, however, can cause drastic changes in the operation of the PLL. These factors include noise injected into the PLL through the filter capacitor, filter capacitor leakage, stray impedances on the circuit board, and even humidity or circuit board contamination.

10.10.3 Choosing a Filter Capacitor

As described in [10.10.2 Parametric Influences on Reaction Time](#), the external filter capacitor, C_F , is critical to the stability and reaction time of the PLL. The PLL is also dependent on reference frequency and supply voltage. The value of the capacitor must, therefore, be chosen with supply potential and reference frequency in mind. For proper operation, the external filter capacitor must be chosen according to this equation:

$$C_F = C_{Fact} \left(\frac{V_{DDA}}{f_{RDV}} \right)$$

For acceptable values of C_{Fact} , see [24.2 Maximum Ratings](#). For the value of V_{DDA} , choose the voltage potential at which the MCU is operating. If the power supply is variable, choose a value near the middle of the range of possible supply values.

This equation does not always yield a commonly available capacitor size, so round to the nearest available size. If the value is between two different sizes, choose the higher value for better stability. Choosing the lower size may seem attractive for acquisition time improvement, but the PLL may become unstable. Also, always choose a capacitor with a tight tolerance (± 20 percent or better) and low dissipation.

Section 11. Configuration Register (CONFIG-1)

11.1 Contents

11.2	Introduction	181
11.3	Functional Description	181

11.2 Introduction

This section describes the configuration register (CONFIG-1), which contains bits that configure these options:

- Resets caused by the low-voltage inhibit (LVI) module
- Power to the LVI module
- LVI enabled during stop mode
- Stop mode recovery time (32 CGMXCLK cycles or 4096 CGMXCLK cycles)
- Computer operating properly (COP) module
- STOP instruction enable/disable

11.3 Functional Description

The configuration register is a write-once register. Out of reset, the configuration register will read the default value. Once the register is written, further writes will have no effect until a reset occurs.

NOTE: *If the LVI module and the LVI reset signal are enabled, a reset occurs when V_{DD} falls to a voltage, LVI_{TRIPF} , and remains at or below that level for at least nine consecutive CPU cycles. Once an LVI reset occurs, the MCU remains in reset until V_{DD} rises to a voltage, LVI_{TRIPR} .*

Configuration Register (CONFIG-1)

Address: \$001F

	Bit 7	6	5	4	3	2	1	Bit 0
Read:	LVISTOP	R	LVIRST	LVIPWR	SSREC	COPL	STOP	COPD
Write:								
Reset:	0	1	1	1	0	0	0	0

R = Reserved

Figure 11-1. Configuration Write-Once Register (CONFIG-1)

LVISTOP — LVI Stop Mode Enable Bit

LVISTOP enables the LVI module in stop mode. See [Section 15. Low-Voltage Inhibit \(LVI\) Module](#).

- 1 = LVI enabled during stop mode
- 0 = LVI disabled during stop mode

NOTE: *To have the LVI enabled in stop mode, the LVIPWR must be at a logic 1 and the LVISTOP bit must be at a logic 1. Take note that by enabling the LVI in stop mode, the stop I_{DD} current will be higher and for compatibility when using a MC68HC08AS20 a register bit will have to be written. See the LVI section of the MC68HC08AS20 Advance Information (Motorola document order number MC68HC08AS20/D.)*

LVIRST — LVI Reset Enable Bit

LVIRST enables the reset signal from the LVI module. See [Section 15. Low-Voltage Inhibit \(LVI\) Module](#).

- 1 = LVI module resets enabled
- 0 = LVI module resets disabled

LVIPWR — LVI Power Enable Bit

LVIPWR enables the LVI module. See [Section 15. Low-Voltage Inhibit \(LVI\) Module](#).

- 1 = LVI module power enabled
- 0 = LVI module power disabled

SSREC — Short Stop Recovery Bit

SSREC enables the CPU to exit stop mode with a delay of 32 CGMXCLK cycles instead of a 4096-CGMXCLK cycle delay. See [9.7.2 Stop Mode](#).

- 1 = Stop mode recovery after 32 CGMXCLK cycles
- 0 = Stop mode recovery after 4096 CGMXCLK cycles

NOTE: *If using an external crystal oscillator, do not set the SSREC bit.*

COPL — COP Long Timeout Bit

COPL enables the shorter COP timeout period. See [Section 14. Computer Operating Properly \(COP\) Module](#).

- 1 = COP timeout period is 8,176 CGMXCLK cycles.
- 0 = COP timeout period is 262,128 CGMXCLK cycles.

STOP — STOP Instruction Enable Bit

STOP enables the STOP instruction.

- 1 = STOP instruction enabled
- 0 = STOP instruction treated as illegal opcode

COPD — COP Disable Bit

COPD disables the COP module. See [Section 14. Computer Operating Properly \(COP\) Module](#).

- 1 = COP module disabled
- 0 = COP module enabled

WARNING: *Extra care should be exercised when using this emulation part for development of code to be run in ROM-based M68HC08AS Family parts that the options selected by setting the CONFIG-1 register match exactly the options selected on any ROM code request submitted. The enable/disable logic is not necessarily identical in all parts of the AS Family. If there is any doubt, check with a local field applications representative.*

Configuration Register (CONFIG-1)

The bit in the CONFIG register or MOR (mask option register) used to control the short and long COP timeout has some variation within the A-Family of devices. [Table 11-1](#) is intended to clarify bit 2 within the CONFIG or MOR of a FLASH or ROM device, respectively.

Table 11-1. COP Time Clarification

Device	Register/Bit Location	Bit Name	Value	Definition
MC68HC908AS60	CONFIG-1/bit 2	COPL	1	Short COP timeout
			0	Long COP timeout
MC68HC908AZ60	CONFIG-1/bit 2	COPL	1	Short COP timeout
			0	Long COP timeout
MC68HC08AS32	MOR/bit 2	COPRS	1	Short COP timeout
			0	Long COP timeout
MC68HC08AS20	MOR/bit 2	COPL	1	Short COP timeout
			0	Long COP timeout

Definition:

Short COP timeout: 8,176 CGMXCLK cycles

Long COP timeout: 262,128 CGMXCLK cycles

CGMXCLK is the output of the crystal oscillator circuit and runs at a rate equal to the crystal frequency.

Section 12. Break Module

12.1 Contents

12.2	Introduction	185
12.3	Features	185
12.4	Functional Description	186
12.4.1	Flag Protection During Break Interrupts	187
12.4.2	CPU During Break Interrupts	187
12.4.3	TIM During Break Interrupts	187
12.4.4	COP During Break Interrupts	188
12.5	Low-Power Modes	188
12.5.1	Wait Mode	188
12.5.2	Stop Mode	188
12.6	Break Module Registers	188
12.6.1	Break Status and Control Register	189
12.6.2	Break Address Registers	190

12.2 Introduction

The break module can generate a break interrupt that stops normal program flow at a defined address to enter a background program.

12.3 Features

Features of the break module include:

- Accessible input/output (I/O) registers during break interrupts
- CPU-generated break interrupts
- Software-generated break interrupts
- Computer operating properly (COP) disabling during break interrupts

12.4 Functional Description

When the internal address bus matches the value written in the break address registers, the break module issues a breakpoint signal to the CPU. The CPU then loads the instruction register with a software interrupt instruction (SWI) after completion of the current CPU instruction. The program counter vectors to \$FFFC and \$FFFD (\$FEFC and \$FEFD in monitor mode).

These two events can cause a break interrupt to occur:

- A CPU-generated address (the address in the program counter) matches the contents of the break address registers.
- Software writes a logic 1 to the BRKA bit in the break status and control register.

When a CPU-generated address matches the contents of the break address registers, the break interrupt begins after the CPU completes its current instruction. A return-from-interrupt instruction (RTI) in the break routine ends the break interrupt and returns the MCU to normal operation. [Figure 12-1](#) shows the structure of the break module.

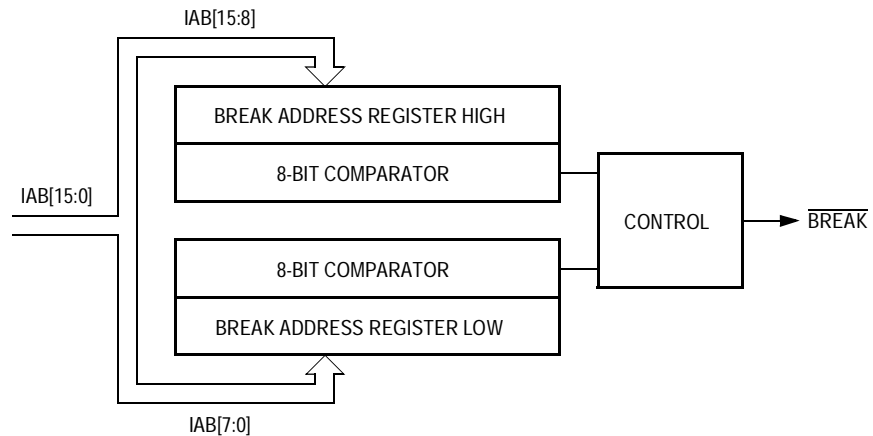

Figure 12-1. Break Module Block Diagram

Addr.	Register Name	Bit 7	6	5	4	3	2	1	Bit 0	
\$FE0C	Break Address Register High (BRKH) See page 190.	Read:	Bit 15	14	13	12	11	10	9	Bit 8
		Write:								
		Reset:	0	0	0	0	0	0	0	0
\$FE0D	Break Address Register Low (BRKL) See page 190.	Read:	Bit 7	6	5	4	3	2	1	Bit 0
		Write:								
		Reset:	0	0	0	0	0	0	0	0
\$FE0E	Break Status and Control Register (BSCR) See page 189.	Read:	BRKE	BRKA	0	0	0	0	0	0
		Write:								
		Reset:	0	0	0	0	0	0	0	0

= Unimplemented

Figure 12-2. I/O Register Summary

12.4.1 Flag Protection During Break Interrupts

The BCFE bit in the break flag control register (BFCR) enables software to clear status bits during the break state.

12.4.2 CPU During Break Interrupts

The CPU starts a break interrupt by:

- Loading the instruction register with the SWI instruction
- Loading the program counter with \$FFFC and \$FFFD (\$FEFC and \$FEFD in monitor mode)

The break interrupt begins after completion of the CPU instruction in progress. If the break address register match occurs on the last cycle of a CPU instruction, the break interrupt begins immediately.

12.4.3 TIM During Break Interrupts

A break interrupt stops the timer counter.

12.4.4 COP During Break Interrupts

The COP is disabled during a break interrupt when V_{HI} is present on the \overline{RST} pin.

12.5 Low-Power Modes

The WAIT and STOP instructions put the MCU in low power-consumption standby modes.

12.5.1 Wait Mode

If enabled, the break module is active in wait mode. The SIM break stop/wait bit (SBSW) in the SIM break status register indicates whether wait was exited by a break interrupt. If so, the user can modify the return address on the stack by subtracting one from it. (See [9.8.1 SIM Break Status Register](#).)

12.5.2 Stop Mode

The break module is inactive in stop mode. The STOP instruction does not affect break module register states. A break interrupt will cause an exit from stop mode and sets the SBSW bit in the SIM break status register.

12.6 Break Module Registers

These registers control and monitor operation of the break module:

- Break address register high, BRKH
- Break address register low, BRKL
- Break status and control register, BSCR

12.6.1 Break Status and Control Register

The break status and control register (BSCR) contains break module enable and status bits.

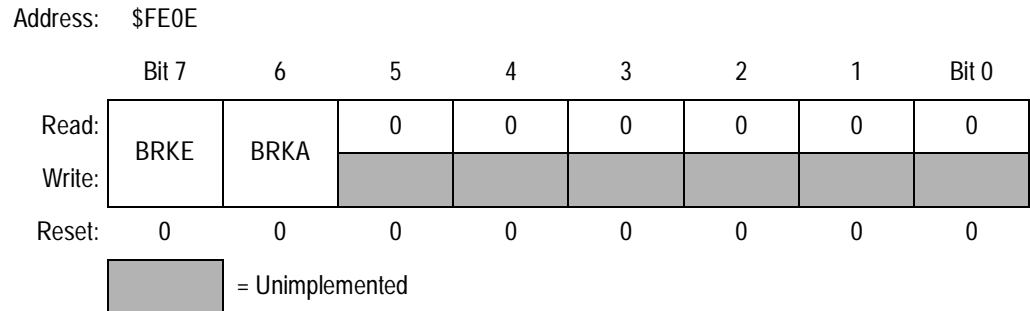

Figure 12-3. Break Status and Control Register (BSCR)

BRKE — Break Enable Bit

This read/write bit enables breaks on break address register matches. Clear BRKE by writing a logic 0 to bit 7. Reset clears the BRKE bit.

- 1 = Breaks enabled on 16-bit address match
- 0 = Breaks disabled on 16-bit address match

BRKA — Break Active Bit

This read/write status and control bit is set when a break address match occurs. Writing a logic 1 to BRKA generates a break interrupt. Clear BRKA by writing a logic 0 to it before exiting the break routine. Reset clears the BRKA bit.

- 1 = When read, break address match
- 0 = When read, no break address match

12.6.2 Break Address Registers

The break address registers (BRKH and BRKL) contain the high and low bytes of the desired breakpoint address. Reset clears the break address registers.

Register Name and Address: BRKH — \$FE0C

	Bit 7	6	5	4	3	2	1	Bit 0
Read:	Bit 15	14	13	12	11	10	9	Bit 8
Write:								
Reset:	0	0	0	0	0	0	0	0

Register Name and Address: BRKL — \$FE0D

	Bit 7	6	5	4	3	2	1	Bit 0
Read:								
Write:								
Reset:	0	0	0	0	0	0	0	0

Figure 12-4. Break Address Registers (BRKH and BRKL)

Section 13. Monitor ROM (MON)

13.1 Contents

13.2	Introduction	191
13.3	Features	192
13.4	Functional Description	192
13.4.1	Entering Monitor Mode	194
13.4.2	Data Format	195
13.4.3	Echoing	196
13.4.4	Break Signal	196
13.4.5	Commands	197
13.4.6	Baud Rate	199
13.4.7	Security	199

13.2 Introduction

This section describes the monitor ROM (MON). The monitor ROM allows complete testing of the MCU through a single-wire interface with a host computer.

13.3 Features

Features of the monitor ROM include:

- Normal user-mode pin functionality
- One pin dedicated to serial communication between monitor ROM and host computer
- Standard mark/space non-return-to-zero (NRZ) communication with host computer
- 4800 baud–28.8 Kbaud communication with host computer
- Execution of code in RAM or FLASH
- FLASH security
- FLASH programming

13.4 Functional Description

Monitor ROM receives and executes commands from a host computer. **Figure 13-1** shows a sample circuit used to enter monitor mode and communicate with a host computer via a standard RS-232 interface.

While simple monitor commands can access any memory address, the MC68HC908AS60 has a FLASH security feature to prevent external viewing of the contents of FLASH. Proper procedures must be followed to verify FLASH content. Access to the FLASH is denied to unauthorized users of customer-specified software (see **13.4.7 Security**).

In monitor mode, the MCU can execute host-computer code in RAM while all MCU pins except PTA0 retain normal operating mode functions. All communication between the host computer and the MCU is through the PTA0 pin. A level-shifting and multiplexing interface is required between PTA0 and the host computer. PTA0 is used in a wired-OR configuration and requires a pullup resistor.

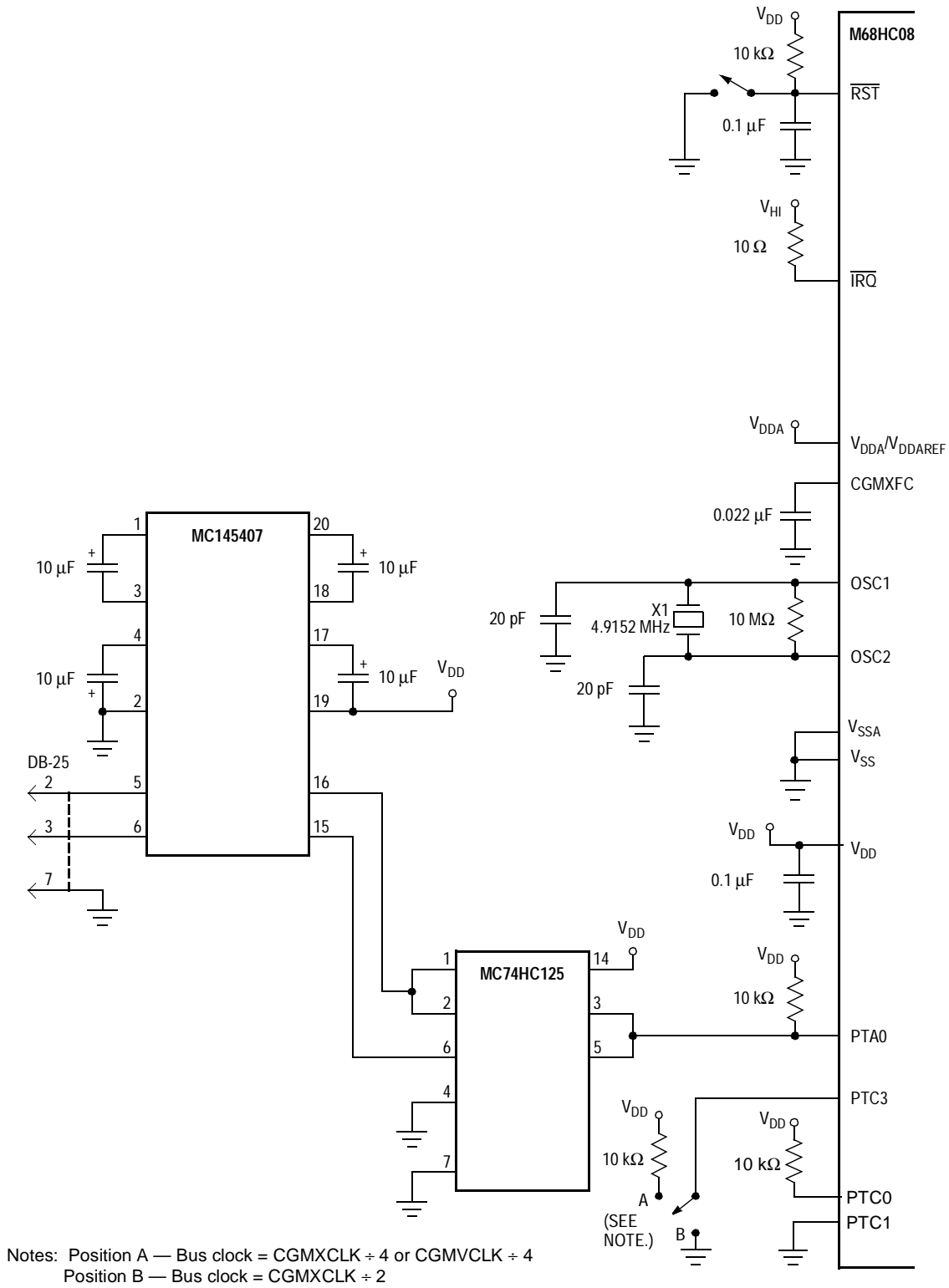

Figure 13-1. Monitor Mode Circuit

13.4.1 Entering Monitor Mode

Table 13-1 shows the pin conditions for entering monitor mode.

Table 13-1. Mode Selection

IRQ Pin	PTC0 Pin	PTC1 Pin	PTA0 Pin	PTC3 Pin	Mode	CGMOUT	Bus Frequency
V _{HI} ⁽¹⁾	1	0	1	1	Monitor	$\frac{CGMXCLK}{2}$ or $\frac{CGMVCLK}{2}$	$\frac{CGMOUT}{2}$
V _{HI} ⁽¹⁾	1	0	1	0	Monitor	CGMXCLK	$\frac{CGMOUT}{2}$

1. For V_{HI}, see 24.5 5.0 Volt DC Electrical Characteristics and 24.2 Maximum Ratings.

Enter monitor mode by either:

- Executing a software interrupt instruction (SWI), or
- Applying a logic 0 and then a logic 1 to the \overline{RST} pin

Once out of reset, the MCU waits for the host to send eight security bytes (see 13.4.7 Security). After the security bytes, the MCU sends a break signal (10 consecutive logic 0s) to the host computer, indicating that it is ready to receive a command.

Monitor mode uses alternate vectors for reset, SWI, and break interrupt. The alternate vectors are in the \$FE page instead of the \$FF page and allow code execution from the internal monitor firmware instead of user code. The COP module is disabled in monitor mode as long as V_{HI} (see 24.5 5.0 Volt DC Electrical Characteristics), is applied to either the \overline{IRQ} pin or the \overline{RST} pin. See Section 9. System Integration Module (SIM) for more information on modes of operation.

NOTE: Holding the PTC3 pin low when entering monitor mode causes a bypass of a divide-by-two stage at the oscillator. The CGMOUT frequency is equal to the CGMXCLK frequency, and the OSC1 input directly generates internal bus clocks. In this case, the OSC1 signal must have a 50 percent duty cycle at maximum bus frequency.

Table 13-2 is a summary of the differences between user mode and monitor mode.

Table 13-2. Mode Differences

Modes	Functions						
	COP	Reset Vector High	Reset Vector Low	Break Vector High	Break Vector Low	SWI Vector High	SWI Vector Low
User	Enabled	\$FFFE	\$FFFF	\$FFFC	\$FFFD	\$FFFC	\$FFFD
Monitor	Disabled ⁽¹⁾	\$FEFE	\$FEFF	\$FEFC	\$FEFD	\$FEFC	\$FEFD

1. If the high voltage (V_{HI}) is removed from the \overline{IRQ} pin while in monitor mode, the SIM asserts its COP enable output. The COP is a mask option enabled or disabled by the COPD bit in the configuration register. See 24.5 5.0 Volt DC Electrical Characteristics.

13.4.2 Data Format

Communication with the MON is in standard non-return-to-zero (NRZ) mark/space data format. (See Figure 13-2 and Figure 13-3.)

The data transmit and receive rate can be anywhere from 4800 baud to 28.8 Kbaud. Transmit and receive baud rates must be identical.

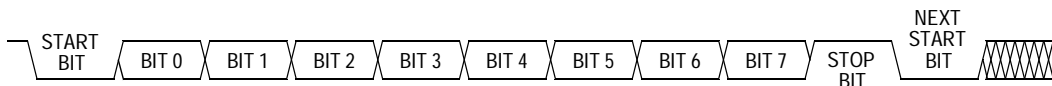

Figure 13-2. Monitor Data Format

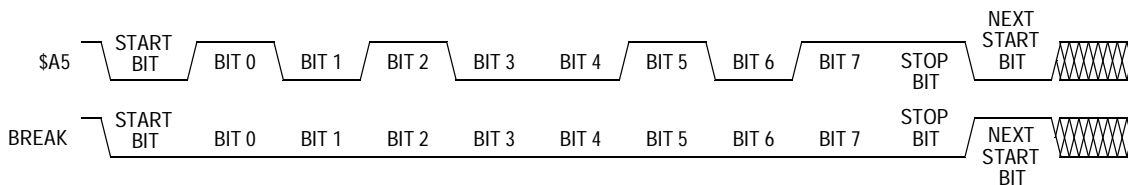

Figure 13-3. Sample Monitor Waveforms

Monitor ROM (MON)

13.4.3 Echoing

As shown in **Figure 13-4**, the MON immediately echoes each received byte back to the PTA0 pin for error checking.

Any result of a command appears after the echo of the last byte of the command.

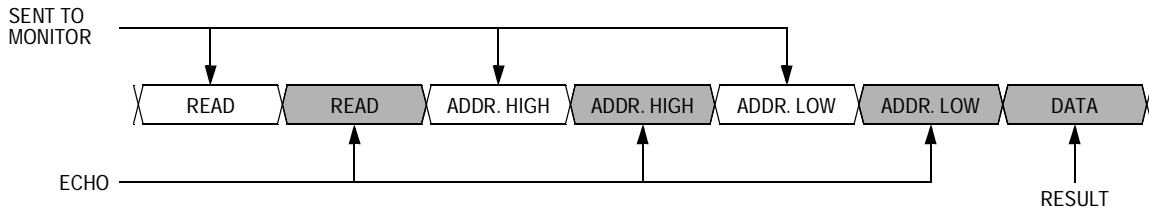

Figure 13-4. Read Transaction

13.4.4 Break Signal

A start bit followed by nine low bits is a break signal. See **Figure 13-5**. When the monitor receives a break signal, it drives the PTA0 pin high for the duration of two bits before echoing the break signal.

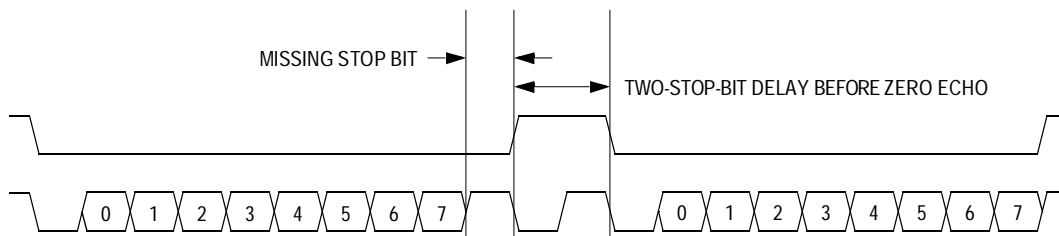

Figure 13-5. Break Transaction

13.4.5 Commands

The monitor ROM uses these commands:

- READ, read memory
- WRITE, write memory
- IREAD, indexed read
- IWRITE, indexed write
- READSP, read stack pointer
- RUN, run user program

A sequence of IREAD or IWRITE commands can access a block of memory sequentially over the full 64-Kbyte memory map.

Table 13-3. READ (Read Memory) Command

Description	Read byte from memory
Operand	Specifies 2-byte address in high byte:low byte order
Data Returned	Returns contents of specified address
Opcode	\$4A
<p>Command Sequence</p>	

Table 13-4. WRITE (Write Memory) Command

Description	Write byte to memory
Operand	Specifies 2-byte address in high byte:low byte order; low byte followed by data byte
Data Returned	None
Opcode	\$49
<p>Command Sequence</p>	

Monitor ROM (MON)

Table 13-5. IREAD (Indexed Read) Command

Description	Read next 2 bytes in memory from last address accessed
Operand	Specifies 2-byte address in high byte:low byte order
Data Returned	Returns contents of next two addresses
Opcode	\$1A
Command Sequence	
<p>The diagram shows a sequence of four blocks: IREAD, IREAD, DATA, and DATA. An arrow labeled 'SENT TO MONITOR' points to the first IREAD block. An arrow labeled 'ECHO' points to the second IREAD block. An arrow labeled 'RESULT' points to the first DATA block. An arrow labeled 'ECHO' also points to the second DATA block.</p>	

Table 13-6. IWRITE (Indexed Write) Command

Description	Write to last address accessed + 1
Operand	Specifies single data byte
Data Returned	None
Opcode	\$19
Command Sequence	
<p>The diagram shows a sequence of four blocks: IWRITE, IWRITE, DATA, and DATA. An arrow labeled 'SENT TO MONITOR' points to the first IWRITE block. An arrow labeled 'ECHO' points to the second IWRITE block. An arrow labeled 'ECHO' also points to the second DATA block.</p>	

Table 13-7. READSP (Read Stack Pointer) Command

Description	Reads stack pointer
Operand	None
Data Returned	Returns stack pointer in high byte:low byte order
Opcode	\$0C
Command Sequence	
<p>The diagram shows a sequence of four blocks: READSP, READSP, SP HIGH, and SP LOW. An arrow labeled 'SENT TO MONITOR' points to the first READSP block. An arrow labeled 'ECHO' points to the second READSP block. An arrow labeled 'RESULT' points to the SP HIGH block. An arrow labeled 'ECHO' also points to the SP LOW block.</p>	

Table 13-8. RUN (Run User Program) Command

Description	Executes RTI instruction
Operand	None
Data Returned	None
Opcode	\$28
<p>Command Sequence</p>	

13.4.6 Baud Rate

With a 4.9152-MHz crystal and the PTC3 pin at logic 1 during reset, data is transferred between the monitor and host at 4800 baud. If the PTC3 pin is at logic 0 during reset, the monitor baud rate is 9600. When the CGM output, CGMOUT, is driven by the PLL, the baud rate is determined by the MUL[7:4] bits in the PLL programming register (PPG). See [Section 10. Clock Generator Module \(CGM\)](#).

Table 13-9. Monitor Baud Rate Selection

Monitor Baud Rate	VCO Frequency Multiplier (N)					
	1	2	3	4	5	6
4.9152 MHz	4800	9600	14,400	19,200	24,000	28,800
4.194 MHz	4096	8192	12,288	16,384	20,480	24,576

13.4.7 Security

A security feature discourages unauthorized reading of FLASH locations while in monitor mode. The host can bypass the security feature at monitor mode entry by sending eight security bytes that match the bytes at locations \$FFF6–\$FFFD. Locations \$FFF6–\$FFFD contain user-defined data.

Monitor ROM (MON)

NOTE: Do not leave locations \$FFF6–\$FFFD blank. For security reasons, program locations \$FFF6–\$FFFD even if they are not used for vectors. If FLASH is unprogrammed, the eight security byte values to be sent are \$FF, the unprogrammed state of FLASH.

During monitor mode entry, the MCU waits after the power-on reset for the host to send the eight security bytes on pin PA0.

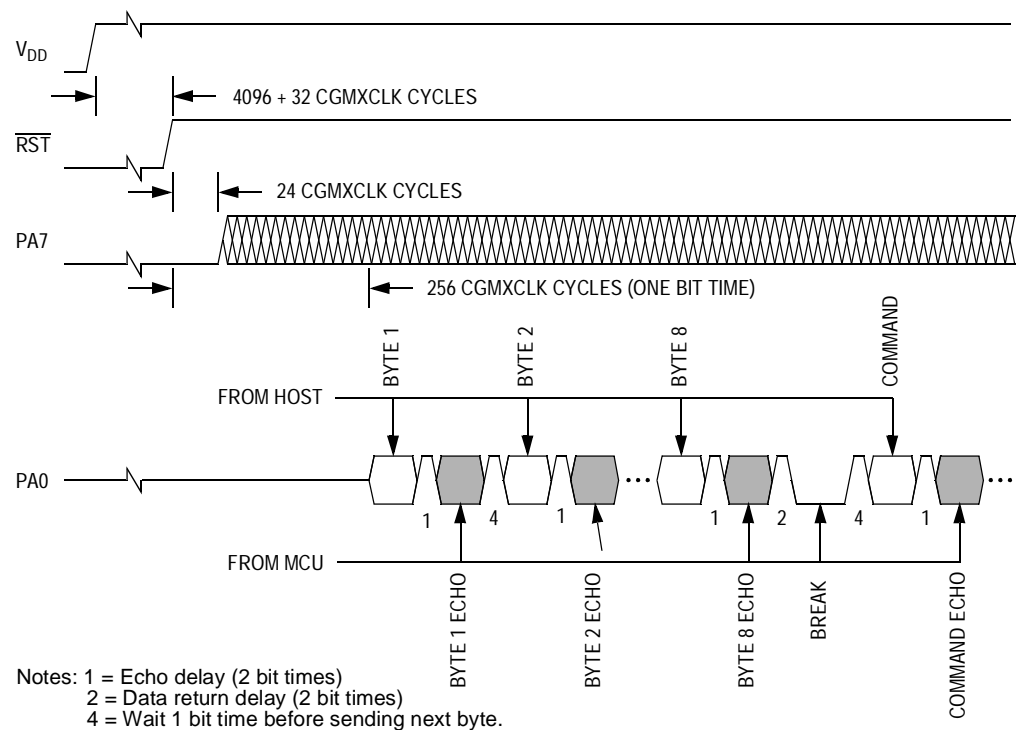

Figure 13-6. Monitor Mode Entry Timing

If the received bytes match those at locations \$FFF6–\$FFFD, the host bypasses the security feature and can read all FLASH locations and execute code from FLASH. Security remains bypassed until a power-on reset occurs. After the host bypasses security, any reset other than a power-on reset requires the host to send another eight bytes. If the reset was not a power-on reset, the security remains bypassed regardless of the data that the host sends.

If the received bytes do not match the data at locations \$FFF6–\$FFFD, the host fails to bypass the security feature. The MCU remains in monitor

mode, but reading FLASH locations returns undefined data, and trying to execute code from FLASH causes an illegal address reset. After the host fails to bypass security, any reset other than a power-on reset causes an endless loop of illegal address resets.

After receiving the eight security bytes from the host, the MCU transmits a break character signalling that it is ready to receive a command.

NOTE: *The MCU does not transmit a break character until after the host sends the eight security bytes.*

Section 14. Computer Operating Properly (COP) Module

14.1 Contents

14.2	Introduction	203
14.3	Functional Description	204
14.4	I/O Signals	205
14.4.1	CGMXCLK	205
14.4.2	STOP Instruction	205
14.4.3	COPCTL Write	206
14.4.4	Power-On Reset	206
14.4.5	Internal Reset	206
14.4.6	Reset Vector Fetch	206
14.4.7	COPD	206
14.4.8	COPL	206
14.5	COP Control Register	207
14.6	Interrupts	207
14.7	Monitor Mode	207
14.8	Low-Power Modes	207
14.8.1	Wait Mode	207
14.8.2	Stop Mode	208
14.9	COP Module During Break Interrupts	208

14.2 Introduction

The computer operating properly (COP) module contains a free-running counter that generates a reset if allowed to overflow. The COP module helps software recover from runaway code. Prevent a COP reset by periodically clearing the COP counter.

14.3 Functional Description

The COP counter is a free-running 6-bit counter preceded by a 12-bit prescaler. If not cleared by software, the COP counter overflows and generates an asynchronous reset after 8,176 or 262,128 CGMXCLK cycles, depending on the state of the COP long timeout bit, COPL, in the CONFIG-1.

$$\text{COP timeout period} = 8,176 \text{ or } 22,128 / f_{\text{OSC}}$$

When COPL = 1, a 4.9152-MHz crystal gives a COP timeout period of 53.3 ms. Writing any value to location \$FFFF before an overflow occurs prevents a COP reset by clearing the COP counter and stages 4–12 of the SIM counter.

NOTE: *Service the COP immediately after reset and before entering or after exiting stop mode to guarantee the maximum time before the first COP counter overflow.*

A COP reset pulls the $\overline{\text{RST}}$ pin low for 32 CGMXCLK cycles and sets the COP bit in the reset status register (RSR).

In monitor mode, the COP is disabled if the $\overline{\text{RST}}$ pin or the $\overline{\text{IRQ}}$ pin is held at V_{HI} . During the break state, V_{HI} on the $\overline{\text{RST}}$ pin disables the COP.

NOTE: *Place COP clearing instructions in the main program and not in an interrupt subroutine. Such an interrupt subroutine could keep the COP from generating a reset even while the main program is not working properly.*

14.4 I/O Signals

This subsection describes the signals shown in [Figure 14-1](#).

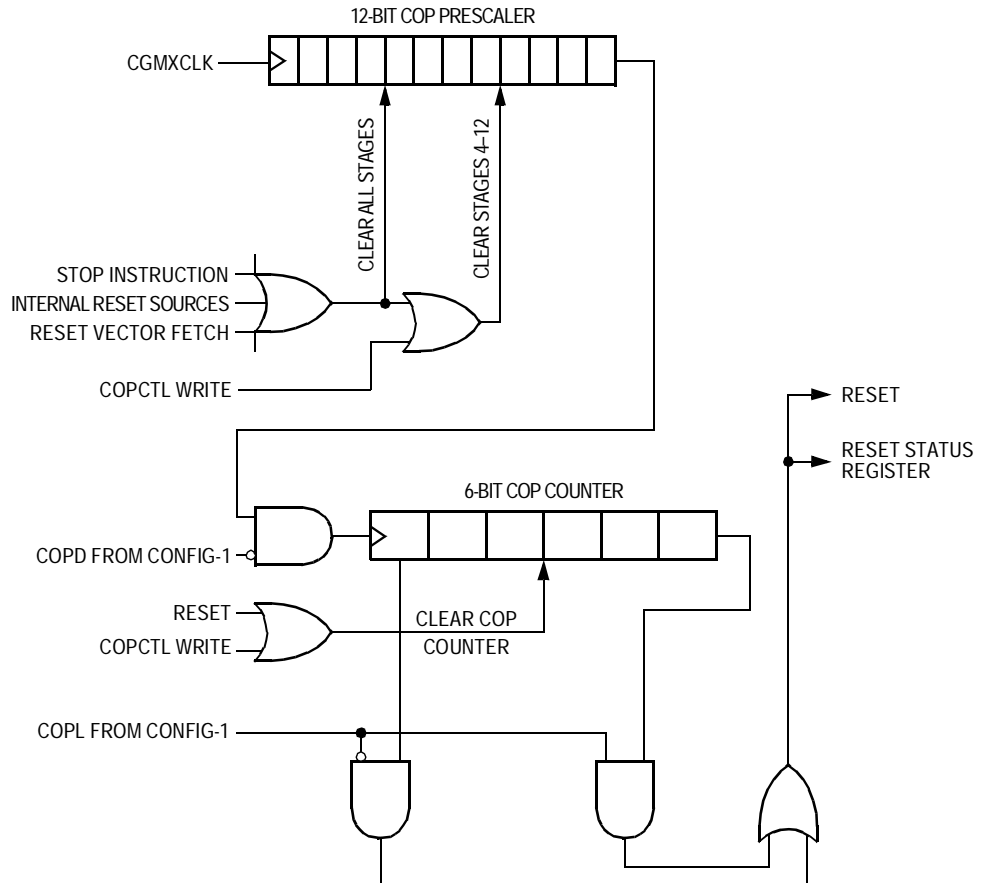

Figure 14-1. COP Block Diagram

14.4.1 CGMXCLK

CGMXCLK is the crystal oscillator output signal. CGMXCLK frequency is equal to the crystal frequency.

14.4.2 STOP Instruction

The STOP instruction clears the COP prescaler.

Computer Operating Properly (COP) Module

14.4.3 COPCTL Write

Writing any value to the COP control register (COPCTL) (see [14.5 COP Control Register](#)) clears the COP counter and clears stages 12 through 4 of the COP prescaler. Reading the COP control register returns the reset vector.

14.4.4 Power-On Reset

The power-on reset (POR) circuit clears the COP prescaler 4096 CGMXCLK cycles after power-up.

14.4.5 Internal Reset

An internal reset clears the COP prescaler and the COP counter.

14.4.6 Reset Vector Fetch

A reset vector fetch occurs when the vector address appears on the data bus. A reset vector fetch clears the COP prescaler.

14.4.7 COPD

The COPD signal reflects the state of the COP disable bit (COPD) in the configuration register. See [Section 11. Configuration Register \(CONFIG-1\)](#).

14.4.8 COPL

The COPL signal reflects the state of the COP rate select bit (COPL) in the configuration register. See [Section 11. Configuration Register \(CONFIG-1\)](#).

14.5 COP Control Register

The COP control register is located at address \$FFFF and overlaps the reset vector. Writing any value to \$FFFF clears the COP counter and starts a new timeout period. Reading location \$FFFF returns the low byte of the reset vector.

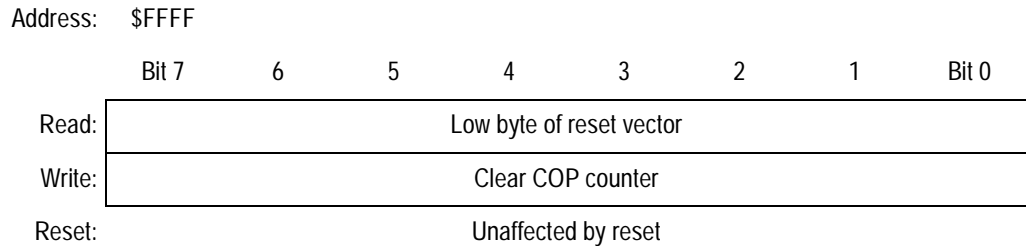

Figure 14-2. COP Control Register (COPCTL)

14.6 Interrupts

The COP does not generate CPU interrupt requests.

14.7 Monitor Mode

The COP is disabled in monitor mode when V_{HI} is present on the \overline{IRQ} pin or on the \overline{RST} pin.

14.8 Low-Power Modes

The WAIT and STOP instructions put the MCU in low power-consumption standby modes.

14.8.1 Wait Mode

The COP remains active in wait mode. To prevent a COP reset during wait mode, periodically clear the COP counter in a CPU interrupt routine.

14.8.2 Stop Mode

Stop mode turns off the CGMXCLK input to the COP and clears the COP prescaler. Service the COP immediately before entering or after exiting stop mode to ensure a full COP timeout period after entering or exiting stop mode.

The STOP bit in the configuration register (CONFIG) enables the STOP instruction. To prevent inadvertently turning off the COP with a STOP instruction, disable the STOP instruction by clearing the STOP bit.

14.9 COP Module During Break Interrupts

The COP is disabled during a break interrupt when V_{HI} is present on the \overline{RST} pin.

Section 15. Low-Voltage Inhibit (LVI) Module

15.1 Contents

15.2	Introduction	209
15.3	Features	210
15.4	Functional Description	210
15.4.1	Polled LVI Operation	211
15.4.2	Forced Reset Operation	211
15.4.3	False Reset Protection	212
15.5	LVI Status Register	212
15.6	LVI Interrupts	213
15.7	Low-Power Modes	213
15.7.1	Wait Mode	213
15.7.2	Stop Mode	213

15.2 Introduction

This section describes the low-voltage inhibit module (LVI47, Version A), which monitors the voltage on the V_{DD} pin and can force a reset when the V_{DD} voltage falls to the LVI trip voltage.

15.3 Features

Features of the LVI module include:

- Programmable LVI reset
- Programmable power consumption
- Digital filtering of V_{DD} pin level

15.4 Functional Description

Figure 15-1 shows the structure of the LVI module. The LVI is enabled out of reset. The LVI module contains a bandgap reference circuit and comparator. The LVI power bit, LVIPWR, enables the LVI to monitor V_{DD} voltage. The LVI reset bit, LVIRST, enables the LVI module to generate a reset when V_{DD} falls below a voltage, LVI_{TRIPF} , and remains at or below that level for nine or more consecutive CPU cycles. LVISTOP enables the LVI module during stop mode. This will ensure when the STOP instruction is implemented, and the LVI will continue to monitor the voltage level on V_{DD} . LVIPWR, LVISTOP, and LVIRST are in the configuration register (CONFIG-1). See **Section 11. Configuration Register (CONFIG-1)**.

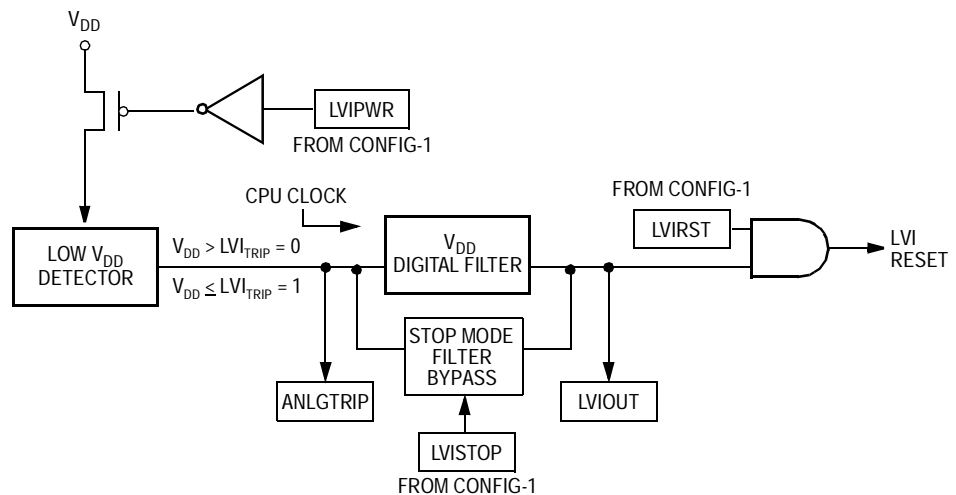

Figure 15-1. LVI Module Block Diagram

Once an LVI reset occurs, the MCU remains in reset until V_{DD} rises above a voltage, LVI_{TRIPR} . V_{DD} must be above LVI_{TRIPR} for only one CPU cycle to bring the MCU out of reset. See **15.4.2 Forced Reset Operation**. The output of the comparator controls the state of the LVIOOUT flag in the LVI status register (LVISR).

An LVI reset also drives the \overline{RST} pin low to provide low-voltage protection to external peripheral devices.

Addr.	Register Name	Bit 7	6	5	4	3	2	1	Bit 0
\$FE0F	LVI Status Register (LVISR) <i>See page 212.</i>	Read:	LVIOOUT	0	0	0	0	0	0
		Write:							
		Reset:	0	0	0	0	0	0	0

= Unimplemented

Figure 15-2. LVI I/O Register Summary

15.4.1 Polled LVI Operation

In applications that can operate at V_{DD} levels below the LVI_{TRIPF} level, software can monitor V_{DD} by polling the LVIOOUT bit. In the configuration register, the LVIPWR bit must be at logic 1 to enable the LVI module, and the LVIRST bit must be at logic 0 to disable LVI resets.

15.4.2 Forced Reset Operation

In applications that require V_{DD} to remain above the LVI_{TRIPF} level, enabling LVI resets allows the LVI module to reset the MCU when V_{DD} falls to the LVI_{TRIPF} level and remains at or below that level for nine or more consecutive CPU cycles. In the configuration register, the LVIPWR and LVIRST bits must be at logic 1 to enable the LVI module and to enable LVI resets.

Low-Voltage Inhibit (LVI) Module

15.4.3 False Reset Protection

The V_{DD} pin level is digitally filtered to reduce false resets due to power supply noise. In order for the LVI module to reset the MCU, V_{DD} must remain at or below the LVI_{TRIPF} level for nine or more consecutive CPU cycles. V_{DD} must be above LVI_{TRIPR} for only one CPU cycle to bring the MCU out of reset.

15.5 LVI Status Register

The LVI status register (LVISR) flags V_{DD} voltages below the LVI_{TRIPF} level.

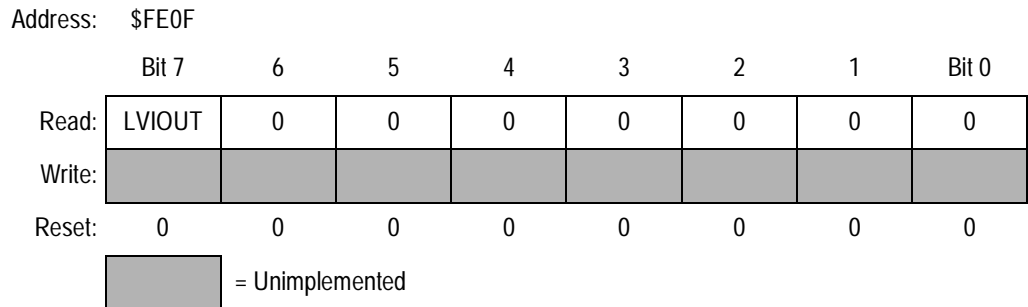

Figure 15-3. LVI Status Register (LVISR)

LVIOUT — LVI Output Bit

This read-only flag becomes set when the V_{DD} voltage falls below the LVI_{TRIPF} voltage for 32 to 40 CGMXCLK cycles. See [Table 15-1](#). Reset clears the LVIOUT bit.

Table 15-1. LVIOUT Bit Indication

V_{DD}		LVIOUT
At Level:	For Number of CGMXCLK Cycles:	
$V_{DD} > LVI_{TRIPR}$	Any	0
$V_{DD} < LVI_{TRIPF}$	< 32 CGMXCLK cycles	0
$V_{DD} < LVI_{TRIPF}$	Between 32 and 40 CGMXCLK Cycles	0 or 1
$V_{DD} < LVI_{TRIPF}$	> 40 CGMXCLK cycles	1
$LVI_{TRIPF} < V_{DD} < LVI_{TRIPR}$	Any	Previous value

15.6 LVI Interrupts

The LVI module does not generate interrupt requests.

15.7 Low-Power Modes

The WAIT and STOP instructions put the MCU in low power-consumption standby modes.

15.7.1 Wait Mode

With the LVIPWR bit in the configuration register programmed to logic 1, the LVI module is active after a WAIT instruction.

With the LVIRST bit in the configuration register programmed to logic 1, the LVI module can generate a reset and bring the MCU out of wait mode.

15.7.2 Stop Mode

With the LVISTOP and LVIPWR bits in the configuration register programmed to a logic 1, the LVI module will be active after a STOP instruction. Because CPU clocks are disabled during stop mode, the LVI trip must bypass the digital filter to generate a reset and bring the MCU out of stop.

With the LVIPWR bit in the configuration register programmed to logic 1 and the LVISTOP bit at a logic 0, the LVI module will be inactive after a STOP instruction.

Section 16. External Interrupt Module (IRQ)

16.1 Contents

16.2	Introduction	215
16.3	Features	215
16.4	Functional Description	216
16.5	$\overline{\text{IRQ}}$ Pin	219
16.6	IRQ Module During Break Interrupts	220
16.7	IRQ Status and Control Register	220

16.2 Introduction

This section describes the non-maskable external interrupt (IRQ) input.

16.3 Features

Features include:

- Dedicated external interrupt pin ($\overline{\text{IRQ}}$)
- Hysteresis buffer
- Programmable edge-only or edge- and level-interrupt sensitivity
- Automatic interrupt acknowledge

External Interrupt Module (IRQ)

16.4 Functional Description

A logic 0 applied to the external interrupt pin can latch a CPU interrupt request. Figure 16-1 shows the structure of the IRQ module.

Interrupt signals on the $\overline{\text{IRQ}}$ pin are latched into the IRQ1 latch. An interrupt latch remains set until one of the following actions occurs:

- Vector fetch — A vector fetch automatically generates an interrupt acknowledge signal that clears the latch that caused the vector fetch.
- Software clear — Software can clear an interrupt latch by writing to the appropriate acknowledge bit in the interrupt status and control register (ISCR). Writing a logic 1 to the ACK1 bit clears the IRQ1 latch.
- Reset — A reset automatically clears both interrupt latches.

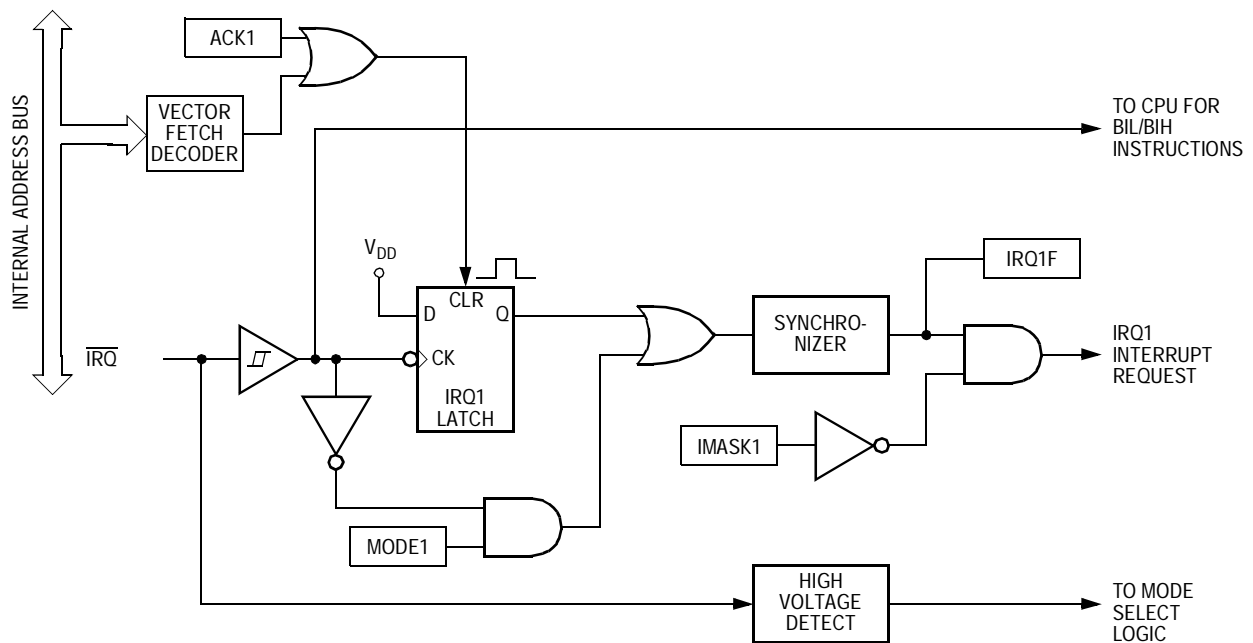

Figure 16-1. IRQ Block Diagram

Addr.	Register Name	Bit 7	6	5	4	3	2	1	Bit 0	
\$001A	IRQ Status and Control Register (ISCR) See page 220.	Read:	0	0	0	0	IRQF1	0	IMASK1	MODE1
		Write:	R	R	R	R	R	ACK1		
		Reset:	0	0	0	0	0	0	0	0

R = Reserved

Figure 16-2. IRQ I/O Register Summary

The external interrupt pin is falling-edge triggered and is software-configurable to be both falling-edge and low-level triggered. The MODE1 bit in the ISCR controls the triggering sensitivity of the \overline{IRQ} pin.

When an interrupt pin is edge-triggered only, the interrupt latch remains set until a vector fetch, software clear, or reset occurs.

When an interrupt pin is both falling-edge and low-level-triggered, the interrupt latch remains set until both of the following occur:

- Vector fetch or software clear
- Return of the interrupt pin to logic 1

The vector fetch or software clear may occur before or after the interrupt pin returns to logic 1. As long as the pin is low, the interrupt request remains pending. A reset will clear the latch and the MODE1 control bit, thereby clearing the interrupt even if the pin stays low.

When set, the IMASK1 bit in the ISCR masks all external interrupt requests. A latched interrupt request is not presented to the interrupt priority logic unless the corresponding IMASK bit is clear.

NOTE: *The interrupt mask (I) in the condition code register (CCR) masks all interrupt requests, including external interrupt requests. (See [Figure 16-3](#).)*

External Interrupt Module (IRQ)

Freescale Semiconductor, Inc.

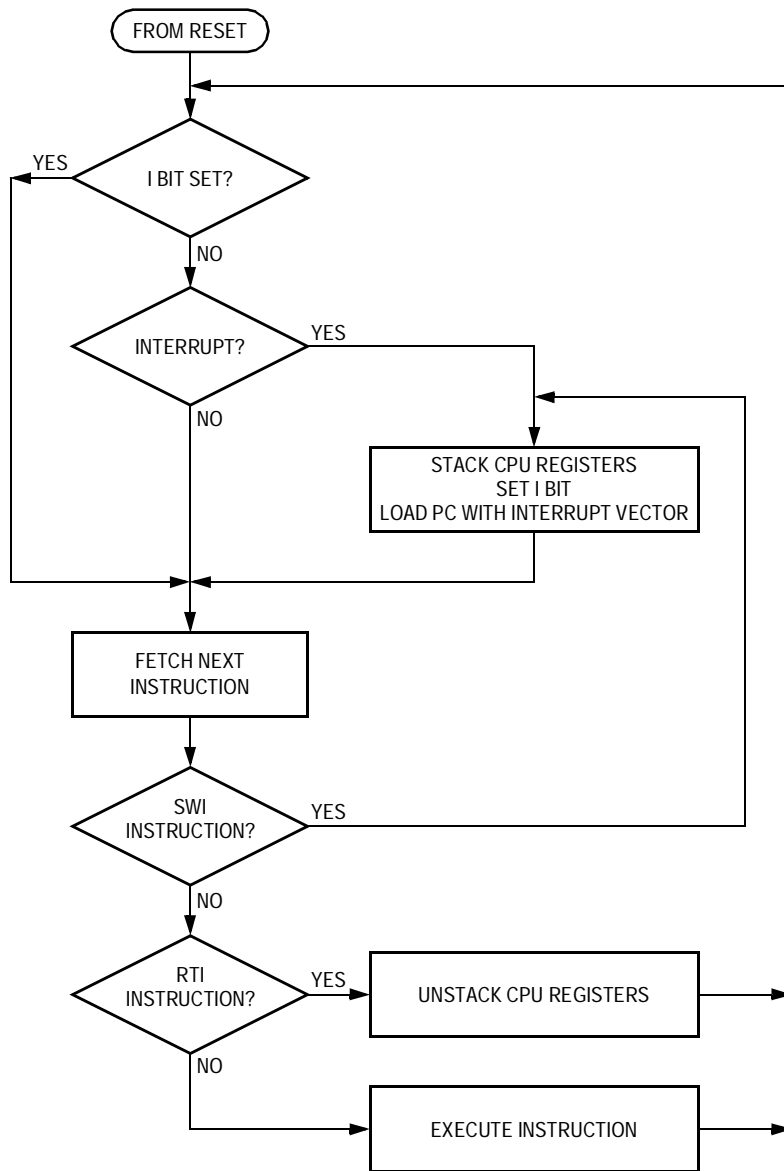

Figure 16-3. IRQ Interrupt Flowchart

16.5 $\overline{\text{IRQ}}$ Pin

A logic 0 on the $\overline{\text{IRQ}}$ pin can latch an interrupt request into the IRQ1 latch. A vector fetch, software clear, or reset clears the IRQ1 latch.

If the MODE1 bit is set, the $\overline{\text{IRQ}}$ pin is both falling-edge sensitive and low-level sensitive. With MODE1 set, both of the following actions must occur to clear the IRQ1 latch:

- Vector fetch or software clear — A vector fetch generates an interrupt acknowledge signal to clear the latch. Software may generate the interrupt acknowledge signal by writing a logic 1 to the ACK1 bit in the interrupt status and control register (ISCR). The ACK1 bit is useful in applications that poll the $\overline{\text{IRQ}}$ pin and require software to clear the IRQ1 latch. Writing to the ACK1 bit can also prevent spurious interrupts due to noise. Setting ACK1 does not affect subsequent transitions on the $\overline{\text{IRQ}}$ pin. A falling edge on $\overline{\text{IRQ}}$ that occurs after writing to the ACK1 bit latches another interrupt request. If the IRQ1 mask bit, IMASK1, is clear, the CPU loads the program counter with the vector address at locations \$FFFA and \$FFFB.
- Return of the $\overline{\text{IRQ}}$ pin to logic 1 — As long as the $\overline{\text{IRQ}}$ pin is at logic 0, the IRQ1 latch remains set.

The vector fetch or software clear and the return of the $\overline{\text{IRQ}}$ pin to logic 1 can occur in any order. The interrupt request remains pending as long as the $\overline{\text{IRQ}}$ pin is at logic 0. A reset will clear the latch and the MODE1 control bit, thereby clearing the interrupt even if the pin stays low.

If the MODE1 bit is clear, the $\overline{\text{IRQ}}$ pin is falling-edge sensitive only. With MODE1 clear, a vector fetch or software clear immediately clears the IRQ1 latch.

The IRQF1 bit in ISCR can be used to check for pending interrupts. The IRQF1 bit is not affected by the IMASK1 bit, which makes it useful in applications where polling is preferred.

Use the BIH or BIL instruction to read the logic level on the $\overline{\text{IRQ}}$ pin.

NOTE: *When using the level-sensitive interrupt trigger, avoid false interrupts by masking interrupt requests in the interrupt routine.*

16.6 IRQ Module During Break Interrupts

The system integration module (SIM) controls whether the IRQ1 interrupt latch can be cleared during the break state. The BCFE bit in the SIM break flag control register (SBFCR) enables software to clear the latches during the break state. See [9.8.3 SIM Break Flag Control Register](#).

To allow software to clear the IRQ1 latch during a break interrupt, write a logic 1 to the BCFE bit. If a latch is cleared during the break state, it remains cleared when the MCU exits the break state.

To protect the latch during the break state, write a logic 0 to the BCFE bit. With BCFE at logic 0 (its default state), writing to the ACK1 bit in the IRQ status and control register during the break state has no effect on the IRQ latch.

16.7 IRQ Status and Control Register

The IRQ status and control register (ISCR) controls and monitors operation of the IRQ module. The ISCR has these functions:

- Shows the state of the IRQ1 interrupt flag
- Clears the IRQ1 interrupt latch
- Masks IRQ1 interrupt request
- Controls triggering sensitivity of the $\overline{\text{IRQ}}$ interrupt pin

Address: \$001A

	Bit 7	6	5	4	3	2	1	Bit 0
Read:	0	0	0	0	IRQF1	0	IMASK1	MODE1
Write:	R	R	R	R	R	ACK1		
Reset:	0	0	0	0	0	0	0	0

R

 = Reserved

Figure 16-4. IRQ Status and Control Register (ISCR)

IRQ1F — IRQ1 Flag Bit

This read-only status bit is high when the IRQ1 interrupt is pending.

1 = $\overline{\text{IRQ}}$ interrupt pending

0 = $\overline{\text{IRQ}}$ interrupt not pending

ACK1 — IRQ1 Interrupt Request Acknowledge Bit

Writing a logic 1 to this write-only bit clears the IRQ1 latch. ACK1 always reads as logic 0. Reset clears ACK1.

IMASK1 — IRQ1 Interrupt Mask Bit

Writing a logic 1 to this read/write bit disables IRQ1 interrupt requests.

Reset clears IMASK1.

1 = IRQ1 interrupt requests disabled

0 = IRQ1 interrupt requests enabled

MODE1 — IRQ1 Edge/Level Select Bit

This read/write bit controls the triggering sensitivity of the $\overline{\text{IRQ}}$ pin.

Reset clears MODE1.

1 = $\overline{\text{IRQ}}$ interrupt requests on falling edges and low levels

0 = $\overline{\text{IRQ}}$ interrupt requests on falling edges only

Section 17. Serial Communications Interface (SCI)

17.1 Contents

17.2	Introduction	224
17.3	Features	224
17.4	Pin Name Conventions	225
17.5	Functional Description	226
17.5.1	Data Format	228
17.5.2	Transmitter	228
17.5.2.1	Character Length	228
17.5.2.2	Character Transmission	228
17.5.2.3	Break Characters	230
17.5.2.4	Idle Characters	230
17.5.2.5	Inversion of Transmitted Output	231
17.5.2.6	Transmitter Interrupts	231
17.5.3	Receiver	232
17.5.3.1	Character Length	233
17.5.3.2	Character Reception	233
17.5.3.3	Data Sampling	233
17.5.3.4	Framing Errors	236
17.5.3.5	Baud Rate Tolerance	236
17.5.3.6	Receiver Wakeup	238
17.5.3.7	Receiver Interrupts	239
17.5.3.8	Error Interrupts	239
17.6	Low-Power Modes	240
17.6.1	Wait Mode	240
17.6.2	Stop Mode	240
17.7	SCI During Break Module Interrupts	241
17.8	I/O Signals	241
17.8.1	PTE0/SCTxD (Transmit Data)	241
17.8.2	PTE1/SCRxD (Receive Data)	242

17.9 I/O Registers 242

17.9.1 SCI Control Register 1 242

17.9.2 SCI Control Register 2 245

17.9.3 SCI Control Register 3 248

17.9.4 SCI Status Register 1 250

17.9.5 SCI Status Register 2 253

17.9.6 SCI Data Register 254

17.9.7 SCI Baud Rate Register 255

17.2 Introduction

The serial communications interface (SCI) allows asynchronous communications with peripheral devices and other MCUs.

17.3 Features

The SCI module’s features include:

- Full-duplex operation
- Standard mark/space non-return-to-zero (NRZ) format
- 32 programmable baud rates
- Programmable 8-bit or 9-bit character length
- Separately enabled transmitter and receiver
- Separate receiver and transmitter CPU interrupt requests
- Programmable transmitter output polarity
- Two receiver wakeup methods:
 - Idle line wakeup
 - Address mark wakeup

- Interrupt-driven operation with eight interrupt flags:
 - Transmitter empty
 - Transmission complete
 - Receiver full
 - Idle receiver input
 - Receiver overrun
 - Noise error
 - Framing error
 - Parity error
- Receiver framing error detection
- Hardware parity checking
- 1/16 bit-time noise detection

17.4 Pin Name Conventions

The generic names of the SCI input/output (I/O) pins are:

- RxD (receive data)
- TxD (transmit data)

SCI I/O lines are implemented by sharing parallel I/O port pins. The full name of an SCI input or output reflects the name of the shared port pin. **Table 17-1** shows the full names and the generic names of the SCI I/O pins.

The generic pin names appear in the text of this section.

Table 17-1. Pin Name Conventions

Generic Pin Names	RxD	TxD
Full Pin Names	PTE1/SCRxD	PTE0/SCTxD

Serial Communications Interface (SCI)

17.5 Functional Description

Figure 17-1 shows the structure of the SCI module. The SCI allows full-duplex, asynchronous, NRZ serial communication between the MCU and remote devices, including other MCUs. The transmitter and receiver of the SCI operate independently, although they use the same baud rate generator. During normal operation, the CPU monitors the status of the SCI, writes the data to be transmitted, and processes received data.

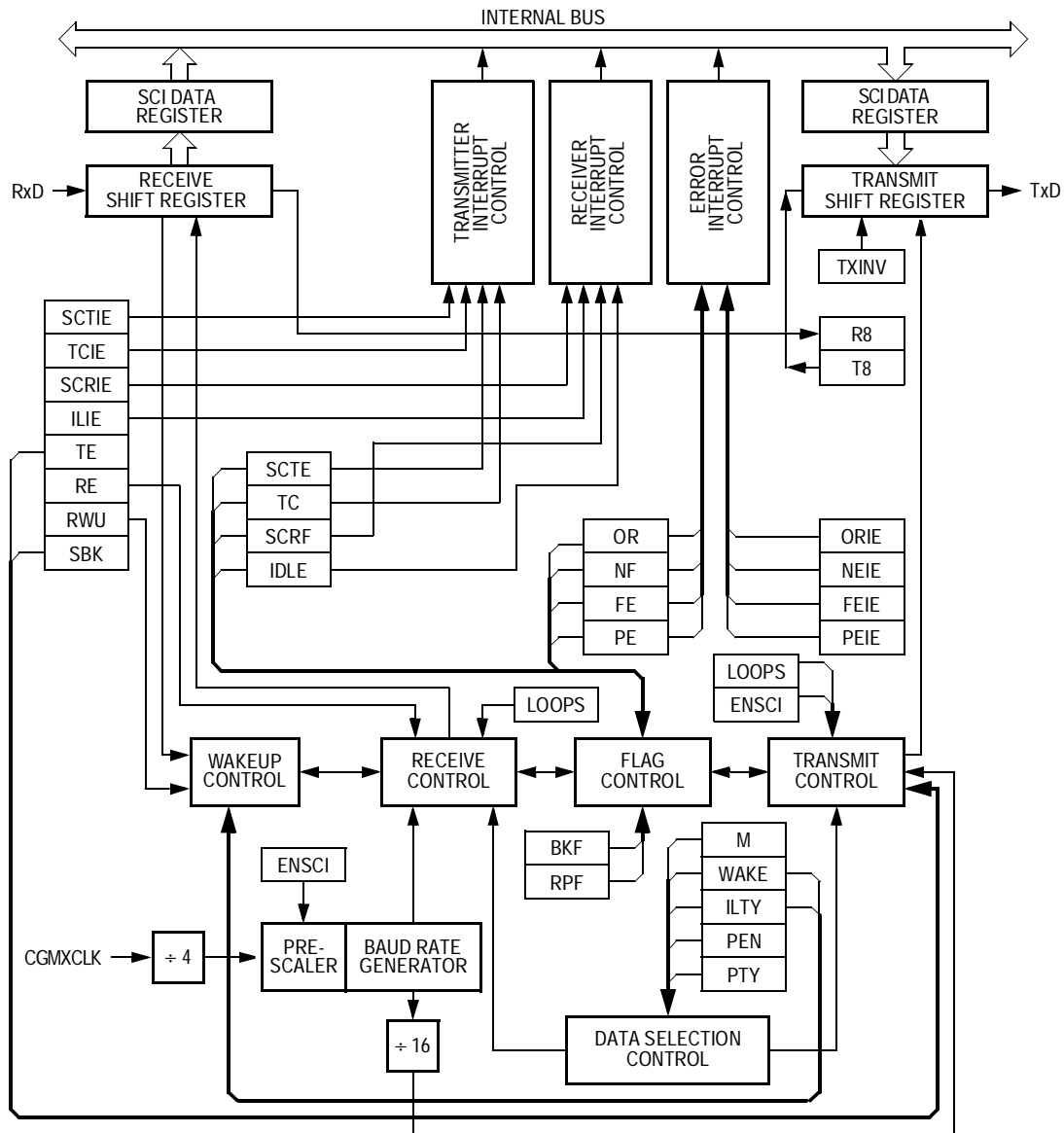

Figure 17-1. SCI Module Block Diagram

Addr.	Register Name	Bit 7	6	5	4	3	2	1	Bit 0	
\$0013	SCI Control Register 1 (SCC1) See page 243.	Read:	LOOPS	ENSCI	TXINV	M	WAKE	ILTY	PEN	PTY
		Write:								
		Reset:	0	0	0	0	0	0	0	0
\$0014	SCI Control Register 2 (SCC2) See page 246.	Read:	SCTIE	TCIE	SCRIE	ILIE	TE	RE	RWU	SBK
		Write:								
		Reset:	0	0	0	0	0	0	0	0
\$0015	SCI Control Register 3 (SCC3) See page 248.	Read:	R8	T8	R	R	ORIE	NEIE	FEIE	PEIE
		Write:								
		Reset:	U	U	0	0	0	0	0	0
\$0016	SCI Status Register 1 (SCS1) See page 250.	Read:	SCTE	TC	SCRF	IDLE	OR	NF	FE	PE
		Write:								
		Reset:	1	1	0	0	0	0	0	0
\$0017	SCI Status Register 2 (SCS2) See page 253.	Read:							BKF	RPF
		Write:								
		Reset:	0	0	0	0	0	0	0	0
\$0018	SCI Data Register (SCDR) See page 254.	Read:	R7	R6	R5	R4	R3	R2	R1	R0
		Write:	T7	T6	T5	T4	T3	T2	T1	T0
		Reset:	Unaffected by reset							
\$0019	SCI Baud Rate Register (SCBR) See page 255.	Read:			SCP1	SCP0	R	SCR2	SCR1	SCR0
		Write:								
		Reset:	0	0	0	0	0	0	0	0

= Unimplemented
 R = Reserved
 U = Unaffected

Figure 17-2. SCI I/O Register Summary

Serial Communications Interface (SCI)

17.5.1 Data Format

The SCI uses the standard non-return-to-zero mark/space data format illustrated in [Figure 17-3](#).

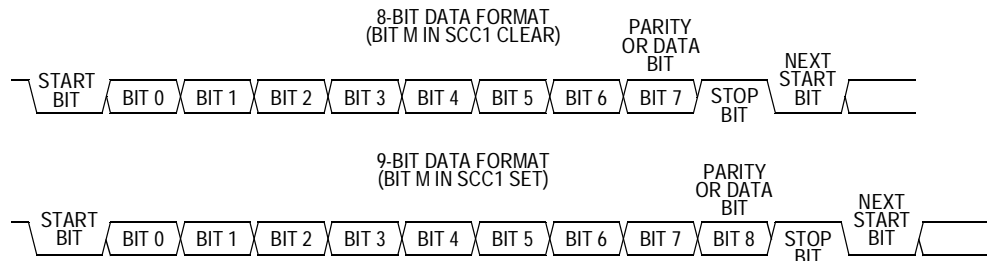

Figure 17-3. SCI Data Formats

17.5.2 Transmitter

[Figure 17-4](#) shows the structure of the SCI transmitter.

17.5.2.1 Character Length

The transmitter can accommodate either 8-bit or 9-bit data. The state of the M bit in SCI control register 1 (SCC1) determines character length. When transmitting 9-bit data, bit T8 in SCI control register 3 (SCC3) is the ninth bit (bit 8).

17.5.2.2 Character Transmission

During an SCI transmission, the transmit shift register shifts a character out to the TxD pin. The SCI data register (SCDR) is the write-only buffer between the internal data bus and the transmit shift register. To initiate an SCI transmission:

1. Enable the SCI by writing a logic 1 to the enable SCI bit (ENSCI) in SCI control register 1 (SCC1).
2. Enable the transmitter by writing a logic 1 to the transmitter enable bit (TE) in SCI control register 2 (SCC2).
3. Clear the SCI transmitter empty bit (SCTE) by first reading SCI status register 1 (SCS1) and then writing to the SCDR.
4. Repeat step 3 for each subsequent transmission.

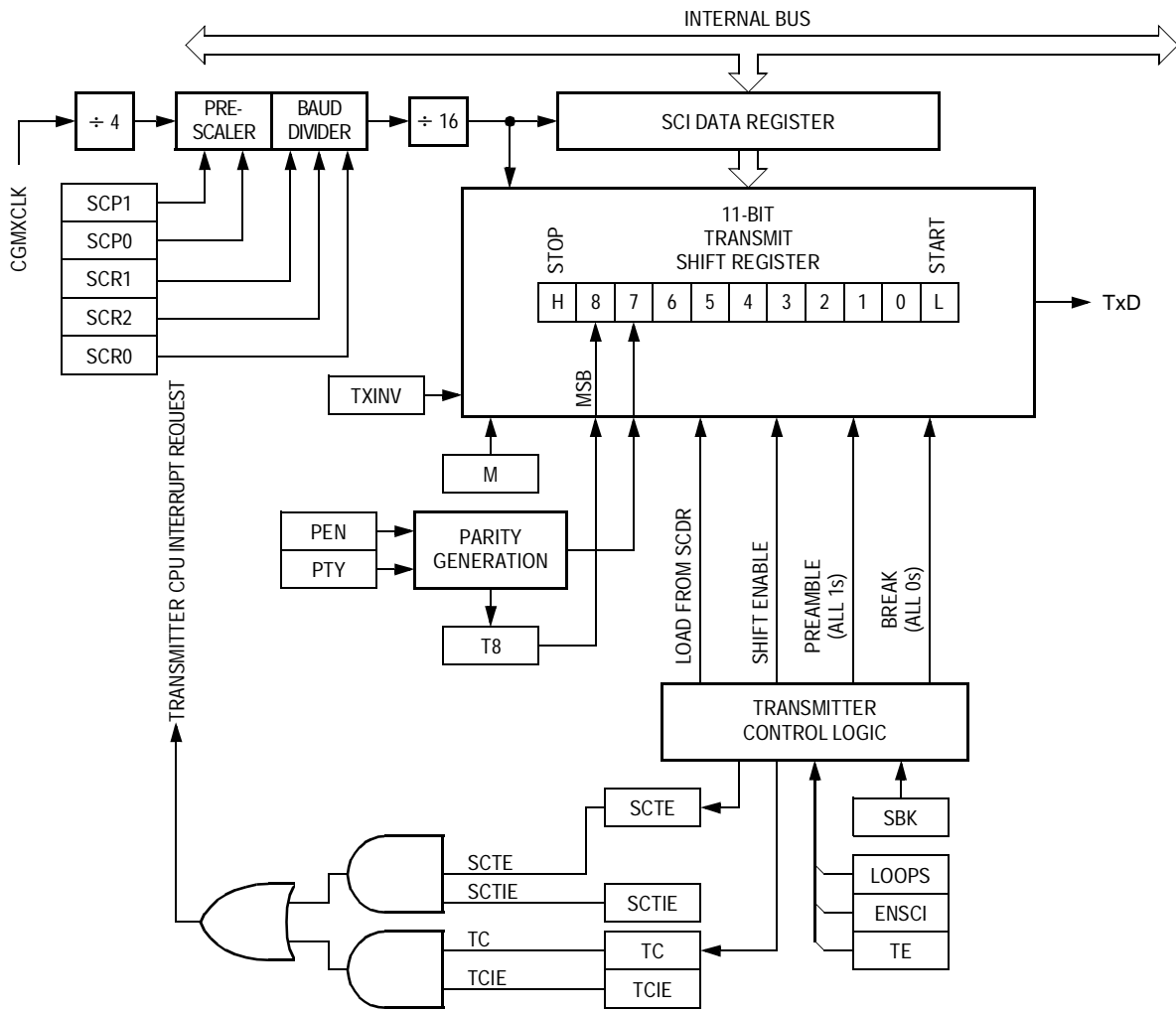

Figure 17-4. SCI Transmitter

At the start of a transmission, transmitter control logic automatically loads the transmit shift register with a preamble of logic 1s. After the preamble shifts out, control logic transfers the SCDR data into the transmit shift register. A logic 0 start bit automatically goes into the least significant bit position of the transmit shift register. A logic 1 stop bit goes into the most significant bit position.

The SCI transmitter empty bit, SCTE, in SCS1 becomes set when the SCDR transfers a byte to the transmit shift register. The SCTE bit indicates that the SCDR can accept new data from the internal data bus.

If the SCI transmit interrupt enable bit, SCTIE, in SCC2 is also set, the SCTE bit generates a transmitter CPU interrupt request.

When the transmit shift register is not transmitting a character, the TxD pin goes to the idle condition, logic 1. If at any time software clears the ENSCI bit in SCI control register 1 (SCC1), the transmitter and receiver relinquish control of the port E pins.

17.5.2.3 Break Characters

Writing a logic 1 to the send break bit, SBK, in SCC2 loads the transmit shift register with a break character. A break character contains all logic 0s and has no start, stop, or parity bit. Break character length depends on the M bit in SCC1. As long as SBK is at logic 1, transmitter logic continuously loads break characters into the transmit shift register. After software clears the SBK bit, the shift register finishes transmitting the last break character and then transmits at least one logic 1. The automatic logic 1 at the end of a break character guarantees the recognition of the start bit of the next character.

The SCI recognizes a break character when a start bit is followed by eight or nine logic 0 data bits and a logic 0 where the stop bit should be. Receiving a break character has these effects on SCI registers:

- Sets the framing error bit (FE) in SCS1
- Sets the SCI receiver full bit (SCRF) in SCS1
- Clears the SCI data register (SCDR)
- Clears the R8 bit in SCC3
- Sets the break flag bit (BKF) in SCS2
- May set the overrun (OR), noise flag (NF), parity error (PE), or reception-in-progress flag (RPF) bits

17.5.2.4 Idle Characters

An idle character contains all logic 1s and has no start, stop, or parity bit. Idle character length depends on the M bit in SCC1. The preamble is a synchronizing idle character that begins every transmission.

If the TE bit is cleared during a transmission, the TxD pin becomes idle after completion of the transmission in progress. Clearing and then setting the TE bit during a transmission queues an idle character to be sent after the character currently being transmitted.

NOTE: *When queuing an idle character, return the TE bit to logic 1 before the stop bit of the current character shifts out to the TxD pin. Setting TE after the stop bit appears on TxD causes data previously written to the SCDR to be lost.*

A good time to toggle the TE bit for a queued idle character is when the SCTE bit becomes set and just before writing the next byte to the SCDR.

17.5.2.5 Inversion of Transmitted Output

The transmit inversion bit (TXINV) in SCI control register 1 (SCC1) reverses the polarity of transmitted data. All transmitted values, including idle, break, start, and stop bits, are inverted when TXINV is at logic 1. See [17.9.1 SCI Control Register 1](#).

17.5.2.6 Transmitter Interrupts

These conditions can generate CPU interrupt requests from the SCI transmitter:

- SCI transmitter empty (SCTE) — The SCTE bit in SCS1 indicates that the SCDR has transferred a character to the transmit shift register. SCTE can generate a transmitter CPU interrupt request. Setting the SCI transmit interrupt enable bit, SCTIE, in SCC2 enables the SCTE bit to generate transmitter CPU interrupt requests.
- Transmission complete (TC) — The TC bit in SCS1 indicates that the transmit shift register and the SCDR are empty and that no break or idle character has been generated. The transmission complete interrupt enable bit, TCIE, in SCC2 enables the TC bit to generate transmitter CPU interrupt requests.

Serial Communications Interface (SCI)

17.5.3 Receiver

Figure 17-5 shows the structure of the SCI receiver.

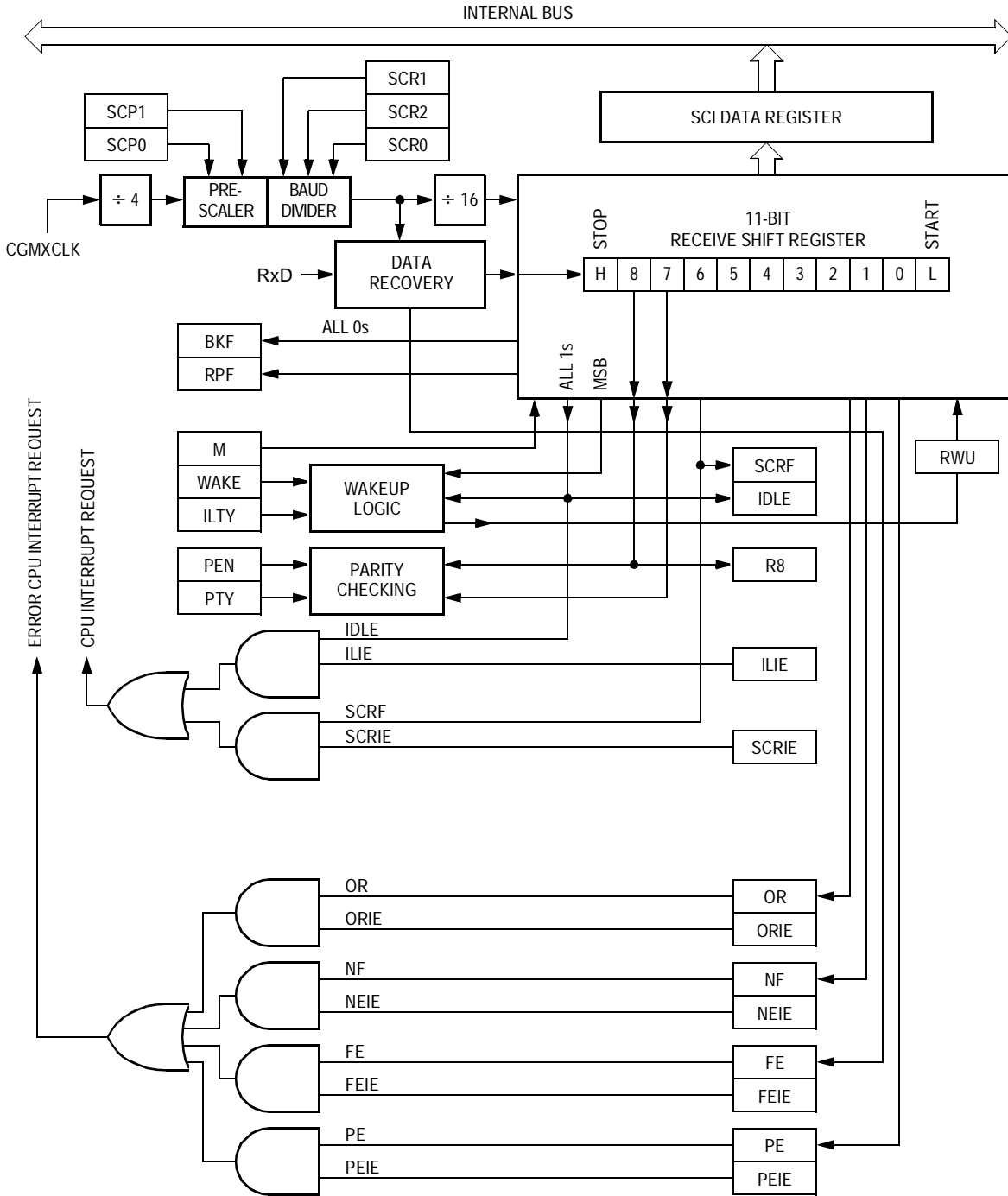

Figure 17-5. SCI Receiver Block Diagram

17.5.3.1 Character Length

The receiver can accommodate either 8-bit or 9-bit data. The state of the M bit in SCI control register 1 (SCC1) determines character length. When receiving 9-bit data, bit R8 in SCI control register 2 (SCC2) is the ninth bit (bit 8). When receiving 8-bit data, bit R8 is a copy of the eighth bit (bit 7).

17.5.3.2 Character Reception

During an SCI reception, the receive shift register shifts characters in from the RxD pin. The SCI data register (SCDR) is the read-only buffer between the internal data bus and the receive shift register.

After a complete character shifts into the receive shift register, the data portion of the character transfers to the SCDR. The SCI receiver full bit, SCRF, in SCI status register 1 (SCS1) becomes set, indicating that the received byte can be read. If the SCI receive interrupt enable bit, SCRIE, in SCC2 is also set, the SCRF bit generates a receiver CPU interrupt request.

17.5.3.3 Data Sampling

The receiver samples the RxD pin at the RT clock rate. The RT clock is an internal signal with a frequency 16 times the baud rate. To adjust for baud rate mismatch, the RT clock is resynchronized at the following times (see [Figure 17-6](#)):

- After every start bit
- After the receiver detects a data bit change from logic 1 to logic 0 (after the majority of data bit samples at RT8, RT9, and RT10 returns a valid logic 1 and the majority of the next RT8, RT9, and RT10 samples returns a valid logic 0)

To locate the start bit, data recovery logic does an asynchronous search for a logic 0 preceded by three logic 1s. When the falling edge of a possible start bit occurs, the RT clock begins to count to 16.

Serial Communications Interface (SCI)

Freescale Semiconductor, Inc.

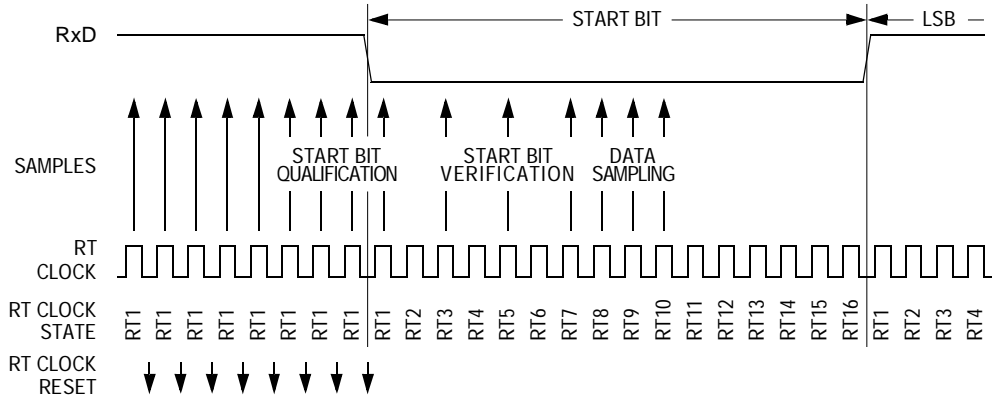

Figure 17-6. Receiver Data Sampling

To verify the start bit and to detect noise, data recovery logic takes samples at RT3, RT5, and RT7. Table 17-2 summarizes the results of the start bit verification samples.

Table 17-2. Start Bit Verification

RT3, RT5, and RT7 Samples	Start Bit Verification	Noise Flag
000	Yes	0
001	Yes	1
010	Yes	1
011	No	0
100	Yes	1
101	No	0
110	No	0
111	No	0

If start bit verification is not successful, the RT clock is reset and a new search for a start bit begins.

To determine the value of a data bit and to detect noise, recovery logic takes samples at RT8, RT9, and RT10. **Table 17-3** summarizes the results of the data bit samples.

Table 17-3. Data Bit Recovery

RT8, RT9, and RT10 Samples	Data Bit Determination	Noise Flag
000	0	0
001	0	1
010	0	1
011	1	1
100	0	1
101	1	1
110	1	1
111	1	0

NOTE: *The RT8, RT9, and RT10 samples do not affect start bit verification. If any or all of the RT8, RT9, and RT10 start bit samples are logic 1s following a successful start bit verification, the noise flag (NF) is set and the receiver assumes that the bit is a start bit.*

To verify a stop bit and to detect noise, recovery logic takes samples at RT8, RT9, and RT10. **Table 17-4** summarizes the results of the stop bit samples.

Table 17-4. Stop Bit Recovery

RT8, RT9, and RT10 Samples	Framing Error Flag	Noise Flag
000	1	0
001	1	1
010	1	1
011	0	1
100	1	1
101	0	1
110	0	1
111	0	0

17.5.3.4 Framing Errors

If the data recovery logic does not detect a logic 1 where the stop bit should be in an incoming character, it sets the framing error bit, FE, in SCS1. A break character also sets the FE bit because a break character has no stop bit. The FE bit is set at the same time that the SCRF bit is set.

17.5.3.5 Baud Rate Tolerance

A transmitting device may be operating at a baud rate below or above the receiver baud rate. Accumulated bit time misalignment can cause one of the three stop bit data samples to fall outside the actual stop bit. Then a noise error occurs. If more than one of the samples is outside the stop bit, a framing error occurs. In most applications, the baud rate tolerance is much more than the degree of misalignment that is likely to occur.

As the receiver samples an incoming character, it resynchronizes the RT clock on any valid falling edge within the character. Resynchronization within characters corrects misalignments between transmitter bit times and receiver bit times.

Slow Data Tolerance

Figure 17-7 shows how much a slow received character can be misaligned without causing a noise error or a framing error. The slow stop bit begins at RT8 instead of RT1 but arrives in time for the stop bit data samples at RT8, RT9, and RT10.

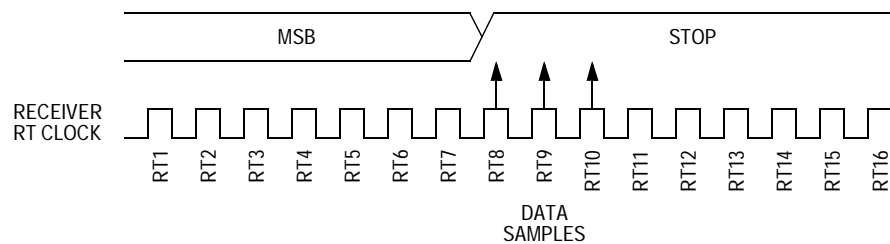

Figure 17-7. Slow Data

For an 8-bit character, data sampling of the stop bit takes the receiver 9 bit times \times 16 RT cycles + 10 RT cycles = 154 RT cycles.

With the misaligned character shown in [Figure 17-7](#), the receiver counts 154 RT cycles at the point when the count of the transmitting device is 9 bit times \times 16 RT cycles + 3 RT cycles = 147 RT cycles.

The maximum percent difference between the receiver count and the transmitter count of a slow 8-bit character with no errors is

$$\left| \frac{154 - 147}{154} \right| \times 100 = 4.54\%$$

For a 9-bit character, data sampling of the stop bit takes the receiver 10 bit times \times 16 RT cycles + 10 RT cycles = 170 RT cycles.

With the misaligned character shown in [Figure 17-7](#), the receiver counts 170 RT cycles at the point when the count of the transmitting device is 10 bit times \times 16 RT cycles + 3 RT cycles = 163 RT cycles.

The maximum percent difference between the receiver count and the transmitter count of a slow 9-bit character with no errors is

$$\left| \frac{170 - 163}{170} \right| \times 100 = 4.12\%$$

Fast Data Tolerance

[Figure 17-8](#) shows how much a fast received character can be misaligned without causing a noise error or a framing error. The fast stop bit ends at RT10 instead of RT16 but is still there for the stop bit data samples at RT8, RT9, and RT10.

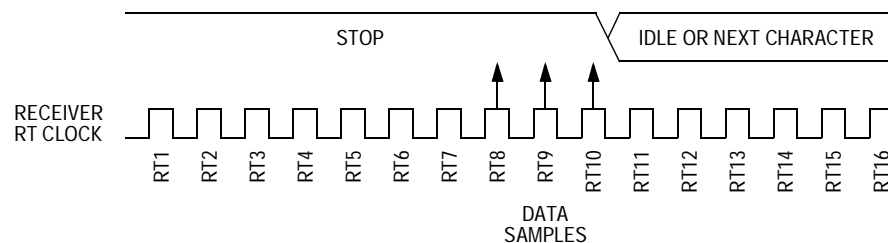

Figure 17-8. Fast Data

For an 8-bit character, data sampling of the stop bit takes the receiver 9 bit times \times 16 RT cycles + 10 RT cycles = 154 RT cycles.

With the misaligned character shown in [Figure 17-8](#), the receiver counts 154 RT cycles at the point when the count of the transmitting device is 10 bit times \times 16 RT cycles = 160 RT cycles.

The maximum percent difference between the receiver count and the transmitter count of a fast 8-bit character with no errors is

$$\left| \frac{154 - 160}{154} \right| \times 100 = 3.90\%$$

For a 9-bit character, data sampling of the stop bit takes the receiver 10 bit times \times 16 RT cycles + 10 RT cycles = 170 RT cycles.

With the misaligned character shown in [Figure 17-8](#), the receiver counts 170 RT cycles at the point when the count of the transmitting device is 11 bit times \times 16 RT cycles = 176 RT cycles.

The maximum percent difference between the receiver count and the transmitter count of a fast 9-bit character with no errors is

$$\left| \frac{170 - 176}{170} \right| \times 100 = 3.53\%$$

17.5.3.6 Receiver Wakeup

So that the MCU can ignore transmissions intended only for other receivers in multiple-receiver systems, the receiver can be put into a standby state. Setting the receiver wakeup bit, RWU, in SCC2 puts the receiver into a standby state during which receiver interrupts are disabled.

Depending on the state of the WAKE bit in SCC1, either of two conditions on the RxD pin can bring the receiver out of the standby state:

- Address mark — An address mark is a logic 1 in the most significant bit position of a received character. When the WAKE bit is set, an address mark wakes the receiver from the standby state by clearing the RWU bit. The address mark also sets the SCI receiver full bit, SCRF. Software can then compare the character containing the address mark to the user-defined address of the

receiver. If they are the same, the receiver remains awake and processes the characters that follow. If they are not the same, software can set the RWU bit and put the receiver back into the standby state.

- Idle input line condition — When the WAKE bit is clear, an idle character on the RxD pin wakes the receiver from the standby state by clearing the RWU bit. The idle character that wakes the receiver does not set the receiver idle bit, IDLE, or the SCI receiver full bit, SCRF. The idle line type bit, ILTY, determines whether the receiver begins counting logic 1s as idle character bits after the start bit or after the stop bit.

NOTE: *With the WAKE bit clear, setting the RWU bit after the RxD pin has been idle may cause the receiver to wake up immediately.*

17.5.3.7 Receiver Interrupts

These sources can generate CPU interrupt requests from the SCI receiver:

- SCI receiver full (SCRF) — The SCRF bit in SCS1 indicates that the receive shift register has transferred a character to the SCDR. SCRF can generate a receiver CPU interrupt request. Setting the SCI receive interrupt enable bit, SCRIE, in SCC2 enables the SCRF bit to generate receiver CPU interrupts.
- Idle input (IDLE) — The IDLE bit in SCS1 indicates that 10 or 11 consecutive logic 1s shifted in from the RxD pin. The idle line interrupt enable bit, ILIE, in SCC2 enables the IDLE bit to generate CPU interrupt requests.

17.5.3.8 Error Interrupts

These receiver error flags in SCS1 can generate CPU interrupt requests:

- Receiver overrun (OR) — The OR bit indicates that the receive shift register shifted in a new character before the previous character was read from the SCDR. The previous character

remains in the SCDR, and the new character is lost. The overrun interrupt enable bit, ORIE, in SCC3 enables OR to generate SCI error CPU interrupt requests.

- Noise flag (NF) — The NF bit is set when the SCI detects noise on incoming data or break characters, including start, data, and stop bits. The noise error interrupt enable bit, NEIE, in SCC3 enables NF to generate SCI error CPU interrupt requests.
- Framing error (FE) — The FE bit in SCS1 is set when a logic 0 occurs where the receiver expects a stop bit. The framing error interrupt enable bit, FEIE, in SCC3 enables FE to generate SCI error CPU interrupt requests.
- Parity error (PE) — The PE bit in SCS1 is set when the SCI detects a parity error in incoming data. The parity error interrupt enable bit, PEIE, in SCC3 enables PE to generate SCI error CPU interrupt requests.

17.6 Low-Power Modes

The WAIT and STOP instructions put the MCU in low power-consumption standby modes.

17.6.1 Wait Mode

The SCI module remains active in wait mode. Any enabled CPU interrupt request from the SCI module can bring the MCU out of wait mode.

If SCI module functions are not required during wait mode, reduce power consumption by disabling the module before executing the WAIT instruction.

17.6.2 Stop Mode

The SCI module is inactive in stop mode. The STOP instruction does not affect SCI register states. SCI module operation resumes after the MCU exits stop mode.

Because the internal clock is inactive during stop mode, entering stop mode during an SCI transmission or reception results in invalid data.

17.7 SCI During Break Module Interrupts

The BCFE bit in the break flag control register (BFCR) enables software to clear status bits during the break state. (See [Section 12. Break Module](#).)

To allow software to clear status bits during a break interrupt, write a logic 1 to the BCFE bit. If a status bit is cleared during the break state, it remains cleared when the MCU exits the break state.

To protect status bits during the break state, write a logic 0 to the BCFE bit. With BCFE at logic 0 (its default state), software can read and write I/O registers during the break state without affecting status bits. Some status bits have a 2-step read/write clearing procedure. If software does the first step on such a bit before the break, the bit cannot change during the break state as long as BCFE is at logic 0. After the break, doing the second step clears the status bit.

17.8 I/O Signals

Port E shares two of its pins with the SCI module. The two SCI I/O pins are:

1. PTE0/SCTxD — Transmit data
2. PTE1/SCRxD — Receive data

17.8.1 PTE0/SCTxD (Transmit Data)

The PTE0/SCTxD pin is the serial data output from the SCI transmitter. The SCI shares the PTE0/SCTxD pin with port E. When the SCI is enabled, the PTE0/SCTxD pin is an output regardless of the state of the DDRE2 bit in data direction register E (DDRE).

17.8.2 PTE1/SCRxD (Receive Data)

The PTE1/SCRxD pin is the serial data input to the SCI receiver. The SCI shares the PTE1/SCRxD pin with port E. When the SCI is enabled, the PTE1/SCRxD pin is an input regardless of the state of the DDRE1 bit in data direction register E (DDRE).

17.9 I/O Registers

These I/O registers control and monitor SCI operation:

- SCI control register 1 (SCC1)
- SCI control register 2 (SCC2)
- SCI control register 3 (SCC3)
- SCI status register 1 (SCS1)
- SCI status register 2 (SCS2)
- SCI data register (SCDR)
- SCI baud rate register (SCBR)

17.9.1 SCI Control Register 1

SCI control register 1:

- Enables loop mode operation
- Enables the SCI
- Controls output polarity
- Controls character length
- Controls SCI wakeup method
- Controls idle character detection
- Enables parity function
- Controls parity type

Address: \$0013

	Bit 7	6	5	4	3	2	1	Bit 0
Read:	LOOPS	ENSCI	TXINV	M	WAKE	ILTY	PEN	PTY
Write:								
Reset:	0	0	0	0	0	0	0	0

Figure 17-9. SCI Control Register 1 (SCC1)

LOOPS — Loop Mode Select Bit

This read/write bit enables loop mode operation. In loop mode the RxD pin is disconnected from the SCI, and the transmitter output goes into the receiver input. Both the transmitter and the receiver must be enabled to use loop mode. Reset clears the LOOPS bit.

- 1 = Loop mode enabled
- 0 = Normal operation enabled

ENSCI — Enable SCI Bit

This read/write bit enables the SCI and the SCI baud rate generator. Clearing ENSCI sets the SCTE and TC bits in SCI status register 1 and disables transmitter interrupts. Reset clears the ENSCI bit.

- 1 = SCI enabled
- 0 = SCI disabled

TXINV — Transmit Inversion Bit

This read/write bit reverses the polarity of transmitted data. Reset clears the TXINV bit.

- 1 = Transmitter output inverted
- 0 = Transmitter output not inverted

NOTE: *Setting the TXINV bit inverts all transmitted values, including idle, break, start, and stop bits.*

M — Mode (Character Length) Bit

This read/write bit determines whether SCI characters are eight or nine bits long. (See [Table 17-5](#).) The ninth bit can serve as an extra stop bit, as a receiver wakeup signal, or as a parity bit. Reset clears the M bit.

- 1 = 9-bit SCI characters
- 0 = 8-bit SCI characters

WAKE — Wakeup Condition Bit

This read/write bit determines which condition wakes up the SCI: a logic 1 (address mark) in the most significant bit position of a received character or an idle condition on the RxD pin. Reset clears the WAKE bit.

- 1 = Address mark wakeup
- 0 = Idle line wakeup

ILTY — Idle Line Type Bit

This read/write bit determines when the SCI starts counting logic 1s as idle character bits. The counting begins either after the start bit or after the stop bit. If the count begins after the start bit, then a string of logic 1s preceding the stop bit may cause false recognition of an idle character. Beginning the count after the stop bit avoids false idle character recognition, but requires properly synchronized transmissions. Reset clears the ILTY bit.

- 1 = Idle character bit count begins after stop bit.
- 0 = Idle character bit count begins after start bit.

PEN — Parity Enable Bit

This read/write bit enables the SCI parity function. (See [Table 17-5](#).) When enabled, the parity function inserts a parity bit in the most significant bit position. (See [Table 17-4](#).) Reset clears the PEN bit.

- 1 = Parity function enabled
- 0 = Parity function disabled

PTY — Parity Bit

This read/write bit determines whether the SCI generates and checks for odd parity or even parity. (See [Table 17-5](#).) Reset clears the PTY bit.

- 1 = Odd parity
- 0 = Even parity

NOTE: *Changing the PTY bit in the middle of a transmission or reception can generate a parity error.*

Table 17-5. Character Format Selection

Control Bits		Character Format				
M	PEN:PTY	Start Bits	Data Bits	Parity	Stop Bits	Character Length
0	0X	1	8	None	1	10 Bits
1	0X	1	9	None	1	11 Bits
0	10	1	7	Even	1	10 Bits
0	11	1	7	Odd	1	10 Bits
1	10	1	8	Even	1	11 Bits
1	11	1	8	Odd	1	11 Bits

17.9.2 SCI Control Register 2

SCI control register 2:

- Enables the following CPU interrupt requests:
 - Enables the SCTE bit to generate transmitter CPU interrupt requests
 - Enables the TC bit to generate transmitter CPU interrupt requests
 - Enables the SCRF bit to generate receiver CPU interrupt requests
 - Enables the IDLE bit to generate receiver CPU interrupt requests
- Enables the transmitter
- Enables the receiver
- Enables SCI wakeup
- Transmits SCI break characters

Serial Communications Interface (SCI)

Address: \$0014

	Bit 7	6	5	4	3	2	1	Bit 0
Read:	SCTIE	TCIE	SCRIE	ILIE	TE	RE	RWU	SBK
Write:								
Reset:	0	0	0	0	0	0	0	0

Figure 17-10. SCI Control Register 2 (SCC2)

SCTIE — SCI Transmit Interrupt Enable Bit

This read/write bit enables the SCTE bit to generate SCI transmitter CPU interrupt requests. Setting the SCTIE bit in SCC3 enables the SCTE bit to generate CPU interrupt requests. Reset clears the SCTIE bit.

- 1 = SCTE enabled to generate CPU interrupt
- 0 = SCTE not enabled to generate CPU interrupt

TCIE — Transmission Complete Interrupt Enable Bit

This read/write bit enables the TC bit to generate SCI transmitter CPU interrupt requests. Reset clears the TCIE bit.

- 1 = TC enabled to generate CPU interrupt requests
- 0 = TC not enabled to generate CPU interrupt requests

SCRIE — SCI Receive Interrupt Enable Bit

This read/write bit enables the SCRF bit to generate SCI receiver CPU interrupt requests. Setting the SCRIE bit in SCC3 enables the SCRF bit to generate CPU interrupt requests. Reset clears the SCRIE bit.

- 1 = SCRF enabled to generate CPU interrupt
- 0 = SCRF not enabled to generate CPU interrupt

ILIE — Idle Line Interrupt Enable Bit

This read/write bit enables the IDLE bit to generate SCI receiver CPU interrupt requests. Reset clears the ILIE bit.

- 1 = IDLE enabled to generate CPU interrupt requests
- 0 = IDLE not enabled to generate CPU interrupt requests

TE — Transmitter Enable Bit

Setting this read/write bit begins the transmission by sending a preamble of 10 or 11 logic 1s from the transmit shift register to the TxD pin. If software clears the TE bit, the transmitter completes any transmission in progress before the TxD returns to the idle condition (logic 1). Clearing and then setting TE during a transmission queues an idle character to be sent after the character currently being transmitted. Reset clears the TE bit.

- 1 = Transmitter enabled
- 0 = Transmitter disabled

NOTE: *Writing to the TE bit is not allowed when the enable SCI bit (ENSCI) is clear. ENSCI is in SCI control register 1.*

RE — Receiver Enable Bit

Setting this read/write bit enables the receiver. Clearing the RE bit disables the receiver but does not affect receiver interrupt flag bits. Reset clears the RE bit.

- 1 = Receiver enabled
- 0 = Receiver disabled

NOTE: *Writing to the RE bit is not allowed when the enable SCI bit (ENSCI) is clear. ENSCI is in SCI control register 1.*

RWU — Receiver Wakeup Bit

This read/write bit puts the receiver in a standby state during which receiver interrupts are disabled. The WAKE bit in SCC1 determines whether an idle input or an address mark brings the receiver out of the standby state and clears the RWU bit. Reset clears the RWU bit.

- 1 = Standby state
- 0 = Normal operation

SBK — Send Break Bit

Setting and then clearing this read/write bit transmits a break character followed by a logic 1. The logic 1 after the break character guarantees recognition of a valid start bit. If SBK remains set, the

Serial Communications Interface (SCI)

transmitter continuously transmits break characters with no logic 1s between them. Reset clears the SBK bit.

- 1 = Transmit break characters
- 0 = No break characters being transmitted

NOTE: Do not toggle the SBK bit immediately after setting the SCTE bit. Toggling SBK before the preamble begins causes the SCI to send a break character instead of a preamble.

17.9.3 SCI Control Register 3

SCI control register 3:

- Stores the ninth SCI data bit received and the ninth SCI data bit to be transmitted
- Enables these interrupts:
 - Receiver overrun interrupts
 - Noise error interrupts
 - Framing error interrupts
 - Parity error interrupts

Address: \$0015

	Bit 7	6	5	4	3	2	1	Bit 0
Read:	R8	T8	R	R	ORIE	NEIE	FEIE	PEIE
Write:								
Reset:	U	U	0	0	0	0	0	0

= Unimplemented
 R = Reserved
 U = Unaffected

Figure 17-11. SCI Control Register 3 (SCC3)

R8 — Received Bit 8

When the SCI is receiving 9-bit characters, R8 is the read-only ninth bit (bit 8) of the received character. R8 is received at the same time that the SCDR receives the other eight bits.

When the SCI is receiving 8-bit characters, R8 is a copy of the eighth bit (bit 7). Reset has no effect on the R8 bit.

T8 — Transmitted Bit 8

When the SCI is transmitting 9-bit characters, T8 is the read/write ninth bit (bit 8) of the transmitted character. T8 is loaded into the transmit shift register at the same time that the SCDR is loaded into the transmit shift register. Reset has no effect on the T8 bit.

ORIE — Receiver Overrun Interrupt Enable Bit

This read/write bit enables SCI error CPU interrupt requests generated by the receiver overrun bit, OR.

- 1 = SCI error CPU interrupt requests from OR bit enabled
- 0 = SCI error CPU interrupt requests from OR bit disabled

NEIE — Receiver Noise Error Interrupt Enable Bit

This read/write bit enables SCI error CPU interrupt requests generated by the noise error bit, NE. Reset clears NEIE.

- 1 = SCI error CPU interrupt requests from NE bit enabled
- 0 = SCI error CPU interrupt requests from NE bit disabled

FEIE — Receiver Framing Error Interrupt Enable Bit

This read/write bit enables SCI error CPU interrupt requests generated by the framing error bit, FE. Reset clears FEIE.

- 1 = SCI error CPU interrupt requests from FE bit enabled
- 0 = SCI error CPU interrupt requests from FE bit disabled

PEIE — Receiver Parity Error Interrupt Enable Bit

This read/write bit enables SCI receiver CPU interrupt requests generated by the parity error bit, PE. Reset clears PEIE.

- 1 = SCI error CPU interrupt requests from PE bit enabled
- 0 = SCI error CPU interrupt requests from PE bit disabled

Serial Communications Interface (SCI)

17.9.4 SCI Status Register 1

SCI status register 1 contains flags to signal these conditions:

- Transfer of SCDR data to transmit shift register complete
- Transmission complete
- Transfer of receive shift register data to SCDR complete
- Receiver input idle
- Receiver overrun
- Noisy data
- Framing error
- Parity error

Address: \$0016

	Bit 7	6	5	4	3	2	1	Bit 0
Read:	SCTE	TC	SCRIF	IDLE	OR	NF	FE	PE
Write:								
Reset:	1	1	0	0	0	0	0	0

 = Unimplemented

Figure 17-12. SCI Status Register 1 (SCS1)

SCTE — SCI Transmitter Empty Bit

This clearable, read-only bit is set when the SCDR transfers a character to the transmit shift register. SCTE can generate an SCI transmitter CPU interrupt request. When the SCTIE bit in SCC2 is set, SCTE generates an SCI transmitter CPU interrupt request. In normal operation, clear the SCTE bit by reading SCS1 with SCTE set and then writing to SCDR. Reset sets the SCTE bit.

- 1 = SCDR data transferred to transmit shift register
- 0 = SCDR data not transferred to transmit shift register

TC — Transmission Complete Bit

This read-only bit is set when the SCTE bit is set, and no data, preamble, or break character is being transmitted. TC generates an SCI transmitter CPU interrupt request if the TCIE bit in SCC2 is also set. TC is cleared automatically when data, preamble, or break is

queued and ready to be sent. There may be up to 1.5 transmitter clocks of latency between queueing data, preamble, and break and the transmission actually starting. Reset sets the TC bit.

1 = No transmission in progress

0 = Transmission in progress

SCRF — SCI Receiver Full Bit

This clearable, read-only bit is set when the data in the receive shift register transfers to the SCI data register. SCRF can generate an SCI receiver CPU interrupt request. When the SCRIE bit in SCC2 is set, the SCRF generates a CPU interrupt request. In normal operation, clear the SCRF bit by reading SCS1 with SCRF set and then reading the SCDR. Reset clears SCRF.

1 = Received data available in SCDR

0 = Data not available in SCDR

IDLE — Receiver Idle Bit

This clearable, read-only bit is set when 10 or 11 consecutive logic 1s appear on the receiver input. IDLE generates an SCI error CPU interrupt request if the ILIE bit in SCC2 is also set. Clear the IDLE bit by reading SCS1 with IDLE set and then reading the SCDR. After the receiver is enabled, it must receive a valid character that sets the SCRF bit before an idle condition can set the IDLE bit. Also, after the IDLE bit has been cleared, a valid character must again set the SCRF bit before an idle condition can set the IDLE bit. Reset clears the IDLE bit.

1 = Receiver input idle

0 = Receiver input active (or idle since the IDLE bit was cleared)

OR — Receiver Overrun Bit

This clearable, read-only bit is set when software fails to read the SCDR before the receive shift register receives the next character. The OR bit generates an SCI error CPU interrupt request if the ORIE bit in SCC3 is also set. The data in the shift register is lost, but the data already in the SCDR is not affected. Clear the OR bit by reading SCS1 with OR set and then reading the SCDR. Reset clears the OR bit.

1 = Receive shift register full and SCRF = 1

0 = No receiver overrun

Serial Communications Interface (SCI)

Software latency may allow an overrun to occur between reads of SCS1 and SCDR in the flag-clearing sequence. Figure 17-13 shows the normal flag-clearing sequence and an example of an overrun caused by a delayed flag-clearing sequence. The delayed read of SCDR does not clear the OR bit because OR was not set when SCS1 was read. Byte 2 caused the overrun and is lost. The next flag-clearing sequence reads byte 3 in the SCDR instead of byte 2.

In applications that are subject to software latency or in which it is important to know which byte is lost due to an overrun, the flag-clearing routine can check the OR bit in a second read of SCS1 after reading the data register.

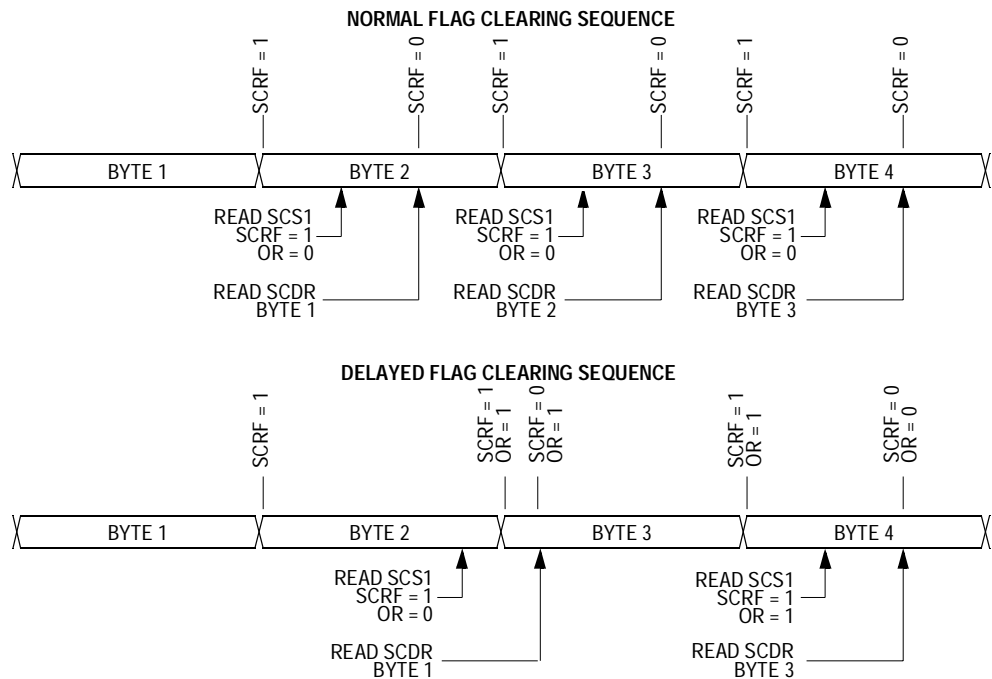

Figure 17-13. Flag Clearing Sequence

NF — Receiver Noise Flag Bit

This clearable, read-only bit is set when the SCI detects noise on the RxD pin. NF generates an NF CPU interrupt request if the NEIE bit in SCC3 is also set. Clear the NF bit by reading SCS1 and then reading the SCDR. Reset clears the NF bit.

- 1 = Noise detected
- 0 = No noise detected

FE — Receiver Framing Error Bit

This clearable, read-only bit is set when a logic 0 is accepted as the stop bit. FE generates an SCI error CPU interrupt request if the FEIE bit in SCC3 also is set. Clear the FE bit by reading SCS1 with FE set and then reading the SCDR. Reset clears the FE bit.

- 1 = Framing error detected
- 0 = No framing error detected

PE — Receiver Parity Error Bit

This clearable, read-only bit is set when the SCI detects a parity error in incoming data. PE generates a PE CPU interrupt request if the PEIE bit in SCC3 is also set. Clear the PE bit by reading SCS1 with PE set and then reading the SCDR. Reset clears the PE bit.

- 1 = Parity error detected
- 0 = No parity error detected

17.9.5 SCI Status Register 2

SCI status register 2 contains flags to signal these conditions:

- Break character detected
- Incoming data

Address: \$0017

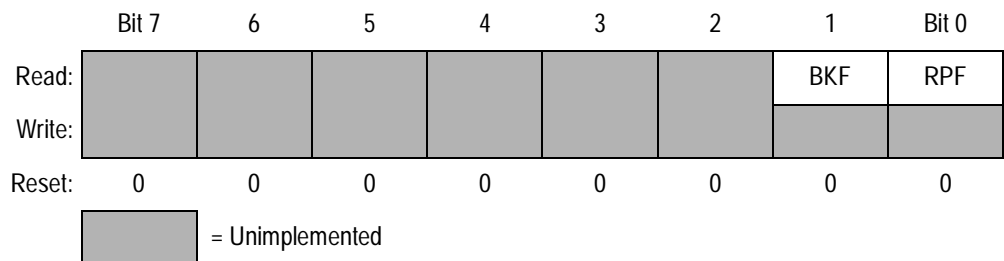

Figure 17-14. SCI Status Register 2 (SCS2)

BKF — Break Flag Bit

This clearable, read-only bit is set when the SCI detects a break character on the RxD pin. In SCS1, the FE and SCRF bits are also set. In 9-bit character transmissions, the R8 bit in SCC3 is cleared. BKF does not generate a CPU interrupt request. Clear BKF by

Serial Communications Interface (SCI)

Freescale Semiconductor, Inc.

reading SCS2 with BKF set and then reading the SCDR. Once cleared, BKF can become set again only after logic 1s again appear on the RxD pin followed by another break character. Reset clears the BKF bit.

- 1 = Break character detected
- 0 = No break character detected

RPF — Reception-in-Progress Flag Bit

This read-only bit is set when the receiver detects a logic 0 during the RT1 time period of the start bit search. RPF does not generate an interrupt request. RPF is reset after the receiver detects false start bits (usually from noise or a baud rate mismatch) or when the receiver detects an idle character. Polling RPF before disabling the SCI module or entering stop mode can show whether a reception is in progress.

- 1 = Reception in progress
- 0 = No reception in progress

17.9.6 SCI Data Register

The SCI data register is the buffer between the internal data bus and the receive and transmit shift registers. Reset has no effect on data in the SCI data register.

Address: \$0018

	Bit 7	6	5	4	3	2	1	Bit 0
Read:	R7	R6	R5	R4	R3	R2	R1	R0
Write:	T7	T6	T5	T4	T3	T2	T1	T0
Reset:	Unaffected by reset							

Figure 17-15. SCI Data Register (SCDR)

R7/T7:R0/T0 — Receive/Transmit Data Bits

Reading address \$0018 accesses the read-only received data bits, R7:R0. Writing to address \$0018 writes the data to be transmitted, T7:T0. Reset has no effect on the SCI data register.

NOTE: Do not use read-modify-write instructions on the SCI data register.

17.9.7 SCI Baud Rate Register

The baud rate register selects the baud rate for both the receiver and the transmitter.

Address: \$0019

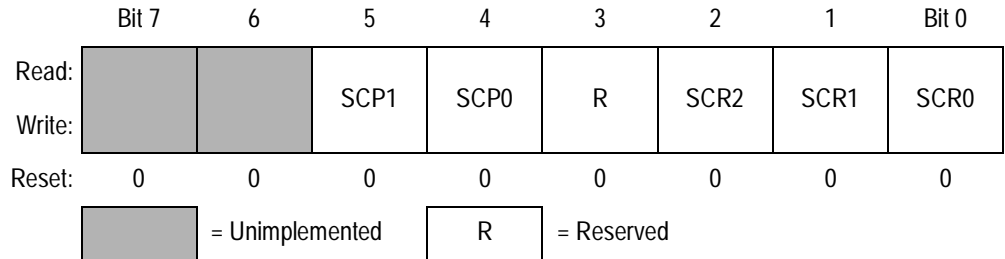

Figure 17-16. SCI Baud Rate Register (SCBR)

SCP1 and SCP0 — SCI Baud Rate Prescaler Bits

These read/write bits select the baud rate prescaler divisor as shown in [Table 17-6](#). Reset clears SCP1 and SCP0.

Table 17-6. SCI Baud Rate Prescaling

SCP[1:0]	Prescaler Divisor (PD)
00	1
01	3
10	4
11	13

SCR2 – SCR0 — SCI Baud Rate Select Bits

These read/write bits select the SCI baud rate divisor as shown in [Table 17-7](#). Reset clears SCR2–SCR0.

Table 17-7. SCI Baud Rate Selection

SCR[2:1:0]	Baud Rate Divisor (BD)
000	1
001	2
010	4
011	8
100	16
101	32
110	64
111	128

Use this formula to calculate the SCI baud rate:

$$\text{Baud rate} = \frac{f_{\text{Crystal}}}{64 \times \text{PD} \times \text{BD}}$$

where:

f_{Crystal} = crystal frequency

PD = prescaler divisor

BD = baud rate divisor

[Table 17-8](#) shows the SCI baud rates that can be generated with a 4.9152-MHz crystal.

Table 17-8. SCI Baud Rate Selection Examples

SCP[1:0]	Prescaler Divisor (PD)	SCR[2:1:0]	Baud Rate Divisor (BD)	Baud Rate (f _{Crystal} = 4.9152 MHz)
00	1	000	1	76,800
00	1	001	2	38,400
00	1	010	4	19,200
00	1	011	8	9600
00	1	100	16	4800
00	1	101	32	2400
00	1	110	64	1200
00	1	111	128	600
01	3	000	1	25,600
01	3	001	2	12,800
01	3	010	4	6400
01	3	011	8	3200
01	3	100	16	1600
01	3	101	32	800
01	3	110	64	400
01	3	111	128	200
10	4	000	1	19,200
10	4	001	2	9600
10	4	010	4	4800
10	4	011	8	2400
10	4	100	16	1200
10	4	101	32	600
10	4	110	64	300
10	4	111	128	150
11	13	000	1	5908
11	13	001	2	2954
11	13	010	4	1477
11	13	011	8	739
11	13	100	16	369
11	13	101	32	185
11	13	110	64	92
11	13	111	128	46

Section 18. Serial Peripheral Interface (SPI)

18.1 Contents

18.2	Introduction	260
18.3	Features	260
18.4	Pin Name and Register Name Conventions	261
18.5	Functional Description	262
18.5.1	Master Mode	263
18.5.2	Slave Mode	265
18.6	Transmission Formats	266
18.6.1	Clock Phase and Polarity Controls	266
18.6.2	Transmission Format When CPHA = 0	267
18.6.3	Transmission Format When CPHA = 1	268
18.6.4	Transmission Initiation Latency	269
18.7	Error Conditions	269
18.7.1	Overflow Error	271
18.7.2	Mode Fault Error	273
18.8	Interrupts	274
18.9	Queuing Transmission Data	276
18.10	Resetting the SPI	277
18.11	Low-Power Modes	278
18.11.1	Wait Mode	278
18.11.2	Stop Mode	278
18.12	SPI During Break Interrupts	278
18.13	I/O Signals	279
18.13.1	MISO (Master In/Slave Out)	280
18.13.2	MOSI (Master Out/Slave In)	280

18.13.3	SPSCK (Serial Clock).....	280
18.13.4	\overline{SS} (Slave Select).....	281
18.13.5	V_{SS} (Clock Ground).....	282
18.14	I/O Registers.....	282
18.14.1	SPI Control Register.....	283
18.14.2	SPI Status and Control Register.....	285
18.14.3	SPI Data Register.....	288

18.2 Introduction

This section describes the serial peripheral interface (SPI) module, which allows full-duplex, synchronous, serial communications with peripheral devices.

18.3 Features

Features of the SPI module include:

- Full-duplex operation
- Master and slave modes
- Double-buffered operation with separate transmit and receive registers
- Four master mode frequencies (maximum = bus frequency \div 2)
- Maximum slave mode frequency = bus frequency
- Serial clock with programmable polarity and phase
- Two separately enabled interrupts with CPU service:
 - SPRF (SPI receiver full)
 - SPTE (SPI transmitter empty)
- Mode fault error flag with CPU interrupt capability
- Overflow error flag with CPU interrupt capability
- Programmable wired-OR mode
- I²C (inter-integrated circuit) compatibility

18.4 Pin Name and Register Name Conventions

The generic names of the SPI input/output (I/O) pins are:

- \overline{SS} (slave select)
- SPSCK (SPI serial clock)
- MOSI (master out/slave in)
- MISO (master in/slave out)

The SPI shares four I/O pins with a parallel I/O port. The full name of an SPI pin reflects the name of the shared port pin. **Table 18-1** shows the full names of the SPI I/O pins. The generic pin names appear in the text that follows.

Table 18-1. Pin Name Conventions

SPI Generic Pin Name	MISO	MOSI	\overline{SS}	SPSCK
Full SPI Pin Name	PTE5/MISO	PTE6/MOSI	PTE4/ \overline{SS}	PTE7/SPSCK

The generic names of the SPI I/O registers are:

- SPI control register (SPCR)
- SPI status and control register (SPSCR)
- SPI data register (SPDR)

Table 18-2 shows the names and the addresses of the SPI I/O registers.

Table 18-2. I/O Register Addresses

Register Name	Address
SPI control register (SPCR)	\$0010
SPI status and control register (SPSCR)	\$0011
SPI data register (SPDR)	\$0012

Serial Peripheral Interface (SPI)

18.5 Functional Description

Figure 18-1 summarizes the SPI I/O registers and Figure 18-2 shows the structure of the SPI module.

Addr.	Register Name	Bit 7	6	5	4	3	2	1	Bit 0	
\$0010	SPI Control Register (SPCR) See page 283.	Read:	SPRIE	R	SPMSTR	CPOL	CPHA	SPWOM	SPE	SPTIE
		Write:								
		Reset:	0	0	1	0	1	0	0	0
\$0011	SPI Status and Control Register (SPSCR) See page 286.	Read:	SPRF	ERRIE	OVRF	MODF	SPTIE	MODFEN	SPR1	SPR0
		Write:	R		R	R	R			
		Reset:	0	0	0	0	1	0	0	0
\$0012	SPI Data Register (SPDR) See page 289.	Read:	R7	R6	R5	R4	R3	R2	R1	R0
		Write:	T7	T6	T5	T4	T3	T2	T1	T0
		Reset:	Unaffected by reset							

R = Reserved

Figure 18-1. SPI I/O Register Summary

The SPI module allows full-duplex, synchronous, serial communication among the MCU and peripheral devices, including other MCUs. Software can poll the SPI status flags or SPI operation can be interrupt driven. All SPI interrupts can be serviced by the CPU.

This subsection describes the operation of the SPI module.

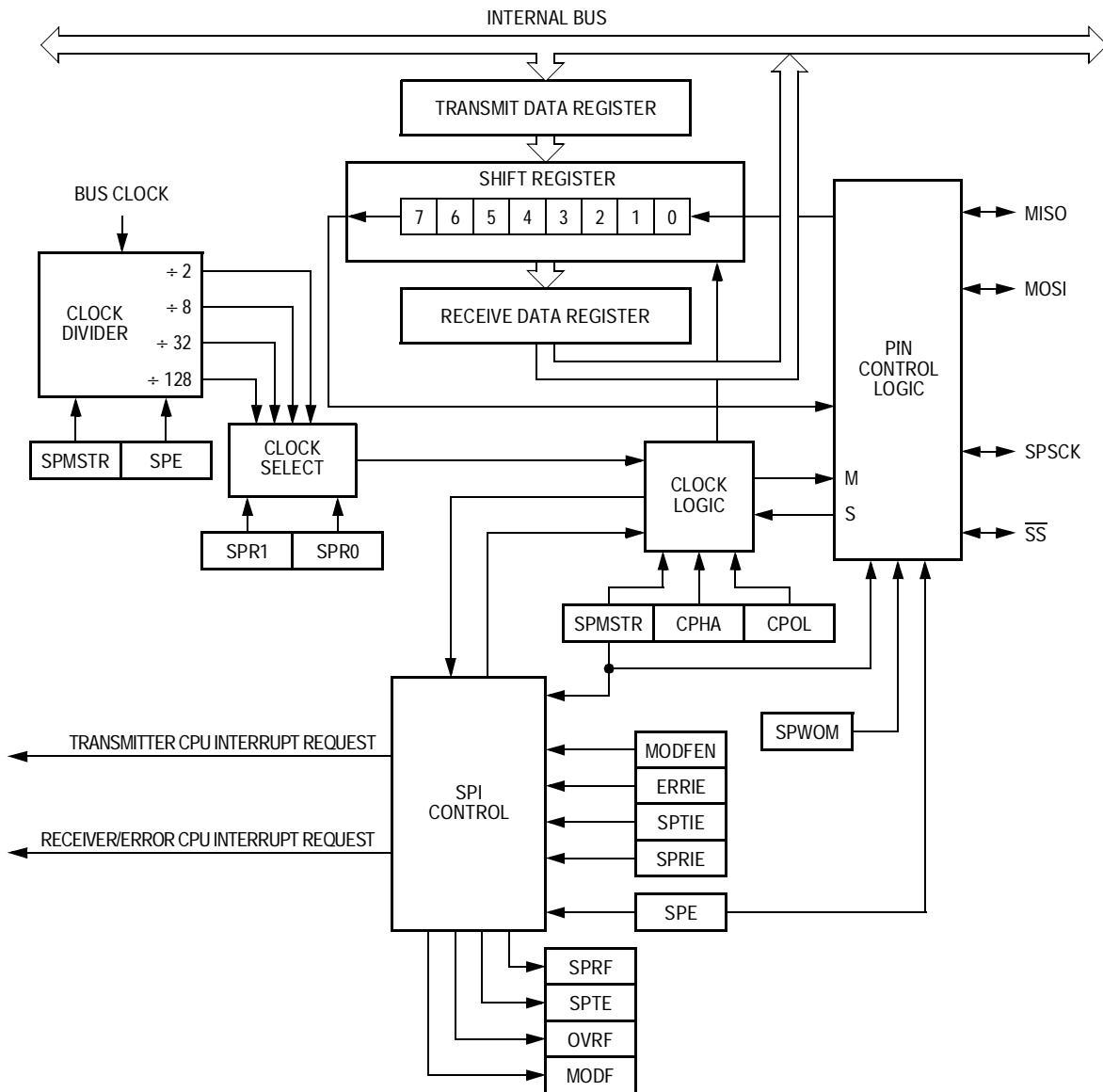

Figure 18-2. SPI Module Block Diagram

18.5.1 Master Mode

The SPI operates in master mode when the SPI master bit, SPMSTR (SPCR \$0010), is set.

NOTE: Configure the SPI modules as master and slave before enabling them. Enable the master SPI before enabling the slave SPI. Disable the slave SPI before disabling the master SPI. See [18.14.1 SPI Control Register](#).

Serial Peripheral Interface (SPI)

Only a master SPI module can initiate transmissions. Software begins the transmission from a master SPI module by writing to the SPI data register. If the shift register is empty, the byte immediately transfers to the shift register, setting the SPI transmitter empty bit, SPTE (SPSCR \$0011). The byte begins shifting out on the MOSI pin under the control of the serial clock. (See [18.8 Interrupts](#).)

The SPR1 and SPR0 bits control the baud rate generator and determine the speed of the shift register. (See [18.14.2 SPI Status and Control Register](#).) Through the SPSCK pin, the baud rate generator of the master also controls the shift register of the slave peripheral.

As the byte shifts out on the MOSI pin of the master, another byte shifts in from the slave on the master's MISO pin. The transmission ends when the receiver full bit, SPRF (SPSCR), becomes set. At the same time that SPRF becomes set, the byte from the slave transfers to the receive data register. In normal operation, SPRF signals the end of a transmission. Software clears SPRF by reading the SPI status and control register and then reading the SPI data register. Writing to the SPI data register clears the SPTE bit.

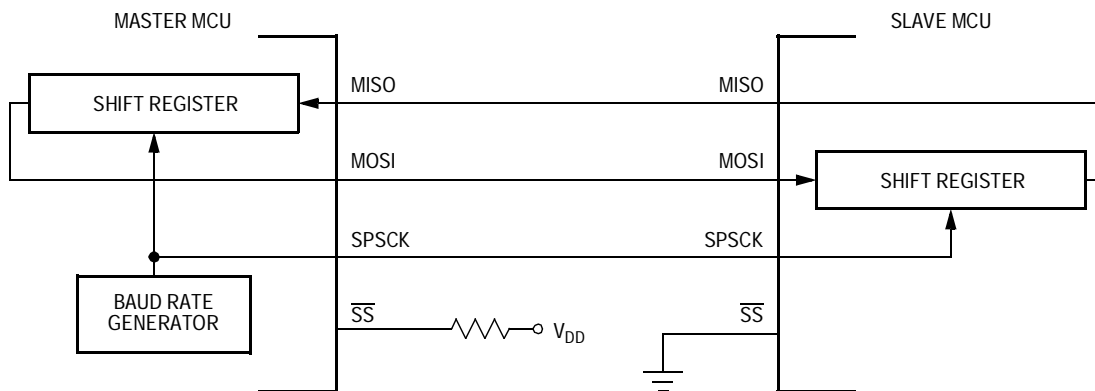

Figure 18-3. Full-Duplex Master-Slave Connections

18.5.2 Slave Mode

The SPI operates in slave mode when the SPMSTR bit (SPCR, \$0010) is clear. In slave mode the SPSCCK pin is the input for the serial clock from the master MCU. Before a data transmission occurs, the \overline{SS} pin of the slave MCU must be at logic 0. \overline{SS} must remain low until the transmission is complete. (See [18.7.2 Mode Fault Error](#).)

In a slave SPI module, data enters the shift register under the control of the serial clock from the master SPI module. After a byte enters the shift register of a slave SPI, it is transferred to the receive data register, and the SPRF bit (SPSCR) is set. To prevent an overflow condition, slave software then must read the SPI data register before another byte enters the shift register.

The maximum frequency of the SPSCCK for an SPI configured as a slave is the bus clock speed, which is twice as fast as the fastest master SPSCCK clock that can be generated. The frequency of the SPSCCK for an SPI configured as a slave does not have to correspond to any SPI baud rate. The baud rate only controls the speed of the SPSCCK generated by an SPI configured as a master. Therefore, the frequency of the SPSCCK for an SPI configured as a slave can be any frequency less than or equal to the bus speed.

When the master SPI starts a transmission, the data in the slave shift register begins shifting out on the MISO pin. The slave can load its shift register with a new byte for the next transmission by writing to its transmit data register. The slave must write to its transmit data register at least one bus cycle before the master starts the next transmission. Otherwise, the byte already in the slave shift register shifts out on the MISO pin. Data written to the slave shift register during a transmission remains in a buffer until the end of the transmission.

When the clock phase bit (CPHA) is set, the first edge of SPSCCK starts a transmission. When CPHA is clear, the falling edge of \overline{SS} starts a transmission. (See [18.6 Transmission Formats](#).)

If the write to the data register is late, the SPI transmits the data already in the shift register from the previous transmission.

NOTE: *To prevent SPSCCK from appearing as a clock edge, SPSCCK must be in the proper idle state before the slave is enabled.*

18.6 Transmission Formats

During an SPI transmission, data is simultaneously transmitted (shifted out serially) and received (shifted in serially). A serial clock line synchronizes shifting and sampling on the two serial data lines. A slave select line allows individual selection of a slave SPI device; slave devices that are not selected do not interfere with SPI bus activities. On a master SPI device, the slave select line can be used optionally to indicate a multiple-master bus contention.

18.6.1 Clock Phase and Polarity Controls

Software can select any of four combinations of serial clock (SCK) phase and polarity using two bits in the SPI control register (SPCR). The clock polarity is specified by the CPOL control bit, which selects an active high or low clock and has no significant effect on the transmission format.

The clock phase (CPHA) control bit (SPCR) selects one of two fundamentally different transmission formats. The clock phase and polarity should be identical for the master SPI device and the communicating slave device. In some cases, the phase and polarity are changed between transmissions to allow a master device to communicate with peripheral slaves having different requirements.

NOTE: *Before writing to the CPOL bit or the CPHA bit (SPCR), disable the SPI by clearing the SPI enable bit (SPE).*

18.6.2 Transmission Format When CPHA = 0

Figure 18-4 shows an SPI transmission in which CPHA (SPCR) is logic 0. The figure should not be used as a replacement for data sheet parametric information. Two waveforms are shown for SCK: one for CPOL = 0 and another for CPOL = 1. The diagram may be interpreted as a master or slave timing diagram since the serial clock (SCK), master in/slave out (MISO), and master out/slave in (MOSI) pins are directly connected between the master and the slave. The MISO signal is the output from the slave, and the MOSI signal is the output from the master. The \overline{SS} line is the slave select input to the slave. The slave SPI drives its MISO output only when its slave select input (\overline{SS}) is at logic 0, so that only the selected slave drives to the master. The \overline{SS} pin of the master is not shown but is assumed to be inactive. The \overline{SS} pin of the master must be high or must be reconfigured as general-purpose I/O not affecting the SPI. (See 18.7.2 Mode Fault Error.) When CPHA = 0, the first SPSCCK edge is the MSB capture strobe. Therefore, the slave must begin driving its data before the first SPSCCK edge, and a falling edge on the \overline{SS} pin is used to start the transmission. The \overline{SS} pin must be toggled high and then low again between each byte transmitted.

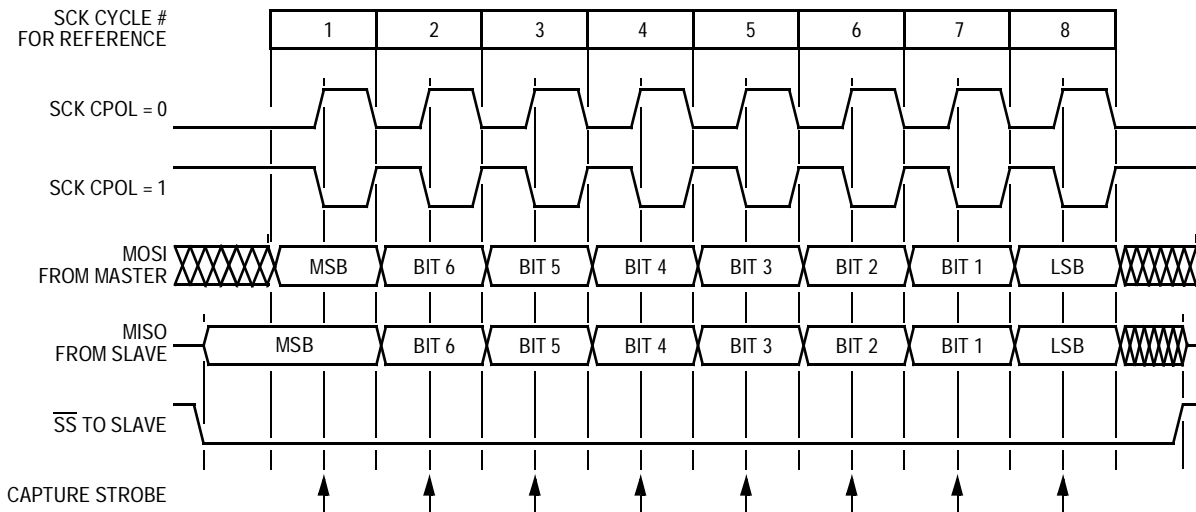

Figure 18-4. Transmission Format (CPHA = 0)

Serial Peripheral Interface (SPI)

18.6.3 Transmission Format When CPHA = 1

Figure 18-5 shows an SPI transmission in which CPHA (SPCR) is logic 1. The figure should not be used as a replacement for data sheet parametric information. Two waveforms are shown for SCK: one for CPOL = 0 and another for CPOL = 1. The diagram may be interpreted as a master or slave timing diagram since the serial clock (SCK), master in/slave out (MISO), and master out/slave in (MOSI) pins are directly connected between the master and the slave. The MISO signal is the output from the slave, and the MOSI signal is the output from the master. The \overline{SS} line is the slave select input to the slave. The slave SPI drives its MISO output only when its slave select input (\overline{SS}) is at logic 0, so that only the selected slave drives to the master. The \overline{SS} pin of the master is not shown but is assumed to be inactive. The \overline{SS} pin of the master must be high or must be reconfigured as general-purpose I/O not affecting the SPI. (See 18.7.2 Mode Fault Error.) When CPHA = 1, the master begins driving its MOSI pin on the first SPSCCK edge. Therefore, the slave uses the first SPSCCK edge as a start transmission signal. The \overline{SS} pin can remain low between transmissions. This format may be preferable in systems having only one master and only one slave driving the MISO data line.

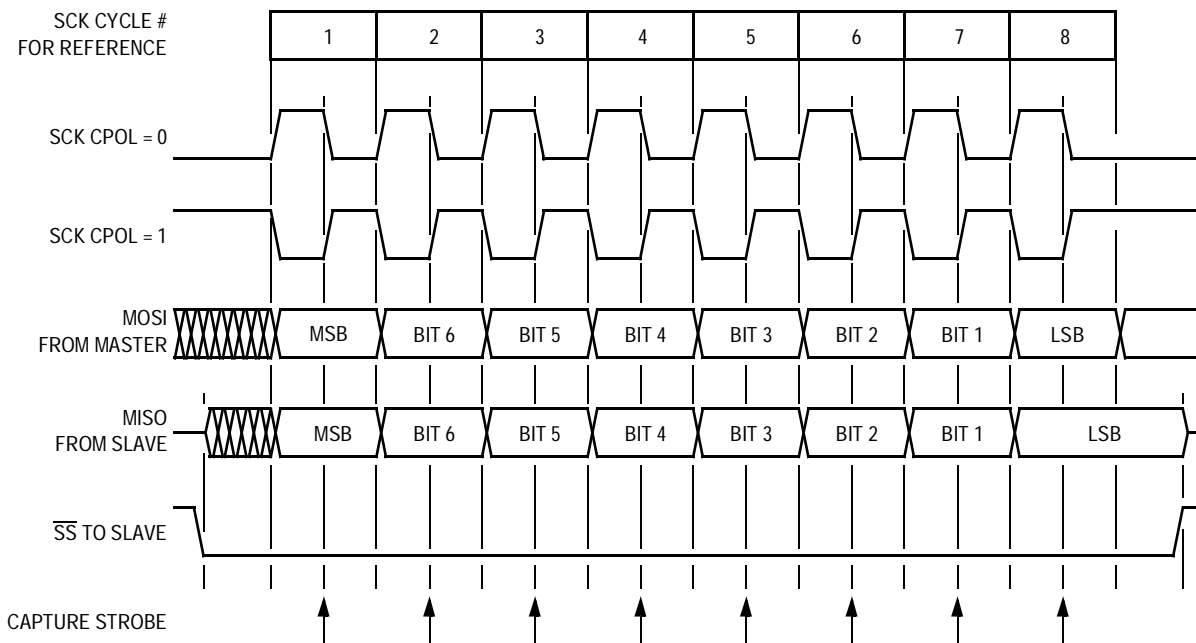

Figure 18-5. Transmission Format (CPHA = 1)

18.6.4 Transmission Initiation Latency

When the SPI is configured as a master ($SPMSTR = 1$), transmissions are started by a software write to the SPDR (\$0012). CPHA has no effect on the delay to the start of the transmission, but it does affect the initial state of the SCK signal. When $CPHA = 0$, the SCK signal remains inactive for the first half of the first SCK cycle. When $CPHA = 1$, the first SCK cycle begins with an edge on the SCK line from its inactive to its active level. The SPI clock rate (selected by $SPR1$ – $SPR0$) affects the delay from the write to SPDR and the start of the SPI transmission. (See [Figure 18-6](#).) The internal SPI clock in the master is a free-running derivative of the internal MCU clock. It is only enabled when both the SPE and SPMSTR bits (SPCR) are set to conserve power. SCK edges occur half way through the low time of the internal MCU clock. Since the SPI clock is free-running, it is uncertain where the write to the SPDR will occur relative to the slower SCK. This uncertainty causes the variation in the initiation delay shown in [Figure 18-6](#). This delay will be no longer than a single SPI bit time. That is, the maximum delay between the write to SPDR and the start of the SPI transmission is two MCU bus cycles for DIV2, eight MCU bus cycles for DIV8, 32 MCU bus cycles for DIV32, and 128 MCU bus cycles for DIV128.

18.7 Error Conditions

Two flags signal SPI error conditions:

1. Overflow (OVRFin SPSCR) — Failing to read the SPI data register before the next byte enters the shift register sets the OVRF bit. The new byte does not transfer to the receive data register, and the unread byte still can be read by accessing the SPI data register. OVRF is in the SPI status and control register.
2. Mode fault error (MODF in SPSCR) — The MODF bit indicates that the voltage on the slave select pin (\overline{SS}) is inconsistent with the mode of the SPI. MODF is in the SPI status and control register.

Serial Peripheral Interface (SPI)

Freescale Semiconductor, Inc.

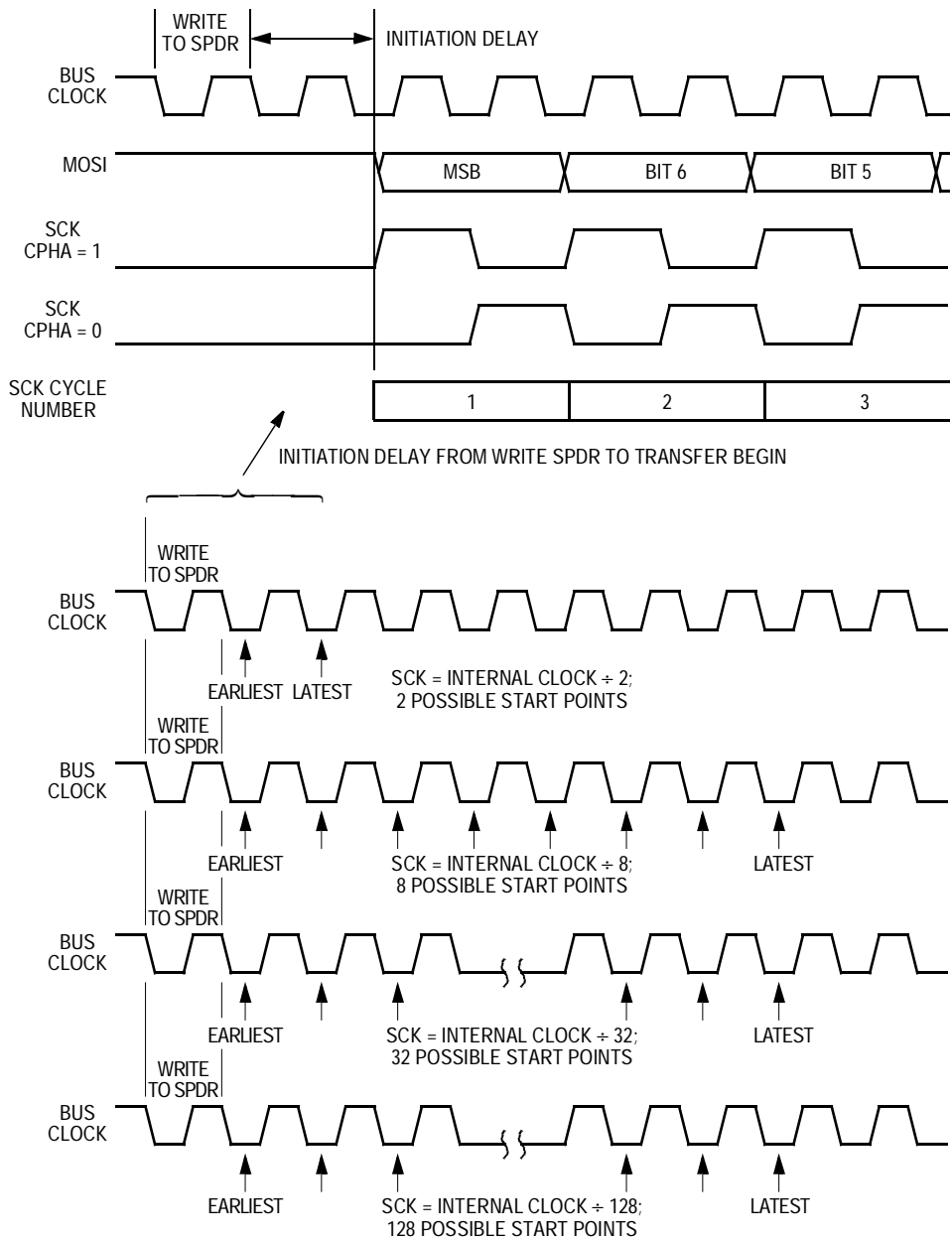

Figure 18-6. Transmission Start Delay (Master)

18.7.1 Overflow Error

The overflow flag (OVRF in SPSCR) becomes set if the SPI receive data register still has unread data from a previous transmission when the capture strobe of bit 1 of the next transmission occurs. (See **Figure 18-4** and **Figure 18-5**.) If an overflow occurs, the data being received is not transferred to the receive data register so that the unread data can still be read. Therefore, an overflow error always indicates the loss of data.

OVRF generates a receiver/error CPU interrupt request if the error interrupt enable bit (ERRIE in SPSCR) is also set. MODF and OVRF can generate a receiver/error CPU interrupt request. (See **Figure 18-9**.) It is not possible to enable only MODF or OVRF to generate a receiver/error CPU interrupt request. However, leaving MODFEN low prevents MODF from being set.

If an end-of-block transmission interrupt was meant to pull the MCU out of wait, having an overflow condition without overflow interrupts enabled causes the MCU to hang in wait mode. If the OVRF is enabled to generate an interrupt, it can pull the MCU out of wait mode instead.

If the CPU SPRF interrupt is enabled and the OVRF interrupt is not, watch for an overflow condition. **Figure 18-7** shows how it is possible to miss an overflow.

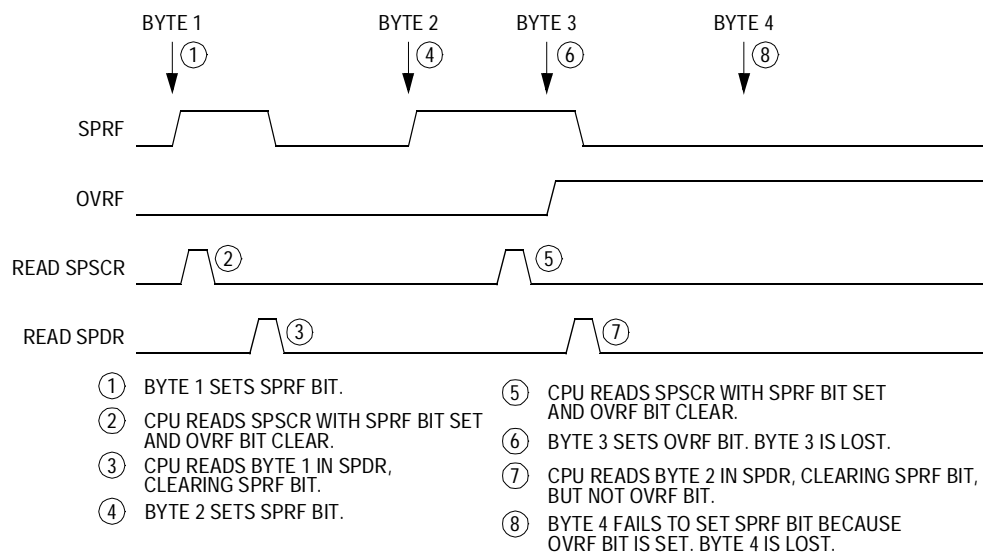

Figure 18-7. Missed Read of Overflow Condition

Serial Peripheral Interface (SPI)

The first part of **Figure 18-7** shows how to read the SPSCR and SPDR to clear the SPRF without problems. However, as illustrated by the second transmission example, the OVRF flag can be set in between the time that SPSCR and SPDR are read.

In this case, an overflow can be easily missed. Since no more SPRF interrupts can be generated until this OVRF is serviced, it will not be obvious that bytes are being lost as more transmissions are completed. To prevent this, either enable the OVRF interrupt or do another read of the SPSCR after the read of the SPDR. This ensures that the OVRF was not set before the SPRF was cleared and that future transmissions will complete with an SPRF interrupt. **Figure 18-8** illustrates this process. Generally, to avoid this second SPSCR read, enable the OVRF to the CPU by setting the ERRIE bit (SPSCR).

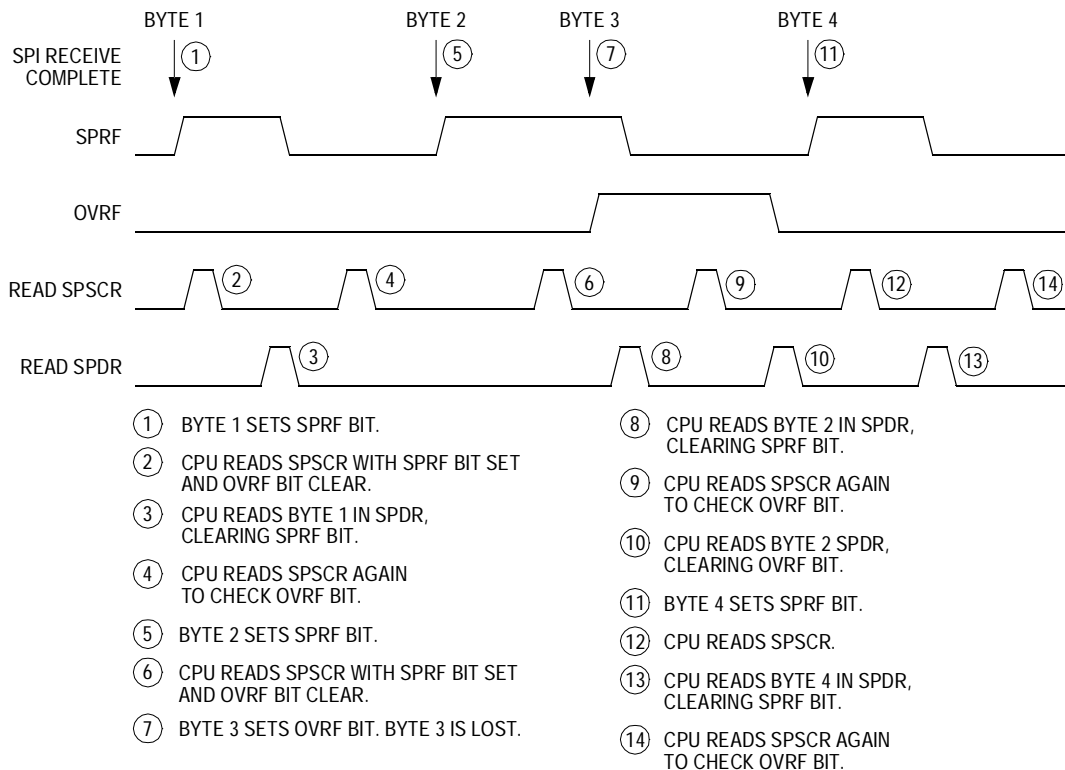

Figure 18-8. Clearing SPRF When OVRF Interrupt Is Not Enabled

18.7.2 Mode Fault Error

For the MODF flag (in SPSCR) to be set, the mode fault error enable bit (MODFEN in SPSCR) must be set. Clearing the MODFEN bit does not clear the MODF flag but does prevent MODF from being set again after MODF is cleared.

MODF generates a receiver/error CPU interrupt request if the error interrupt enable bit (ERRIE in SPSCR) is also set. The SPRF, MODF, and OVRF interrupts share the same CPU interrupt vector. MODF and OVRF can generate a receiver/error CPU interrupt request. (See [Figure 18-9](#).) It is not possible to enable only MODF or OVRF to generate a receiver/error CPU interrupt request. However, leaving MODFEN low prevents MODF from being set.

In a master SPI with the mode fault enable bit (MODFEN) set, the mode fault flag (MODF) is set if \overline{SS} goes to logic 0. A mode fault in a master SPI causes the following events to occur:

- If ERRIE = 1, the SPI generates an SPI receiver/error CPU interrupt request.
- The SPE bit is cleared.
- The SPTE bit is set.
- The SPI state counter is cleared.
- The data direction register of the shared I/O port regains control of port drivers.

NOTE: To prevent bus contention with another master SPI after a mode fault error, clear all data direction register (DDR) bits associated with the SPI shared port pins.

NOTE: Setting the MODF flag (SPSCR) does not clear the SPMSTR bit. Reading SPMSTR when MODF = 1 will indicate a MODE fault error occurred in either master mode or slave mode.

When configured as a slave (SPMSTR = 0), the MODF flag is set if \overline{SS} goes high during a transmission. When CPHA = 0, a transmission begins when \overline{SS} goes low and ends once the incoming SPSCCK returns to its idle level after the shift of the eighth data bit. When CPHA = 1, the

Serial Peripheral Interface (SPI)

transmission begins when the SPSCCK leaves its idle level and \overline{SS} is already low. The transmission continues until the SPSCCK returns to its IDLE level after the shift of the last data bit. (See [18.6 Transmission Formats](#)).

NOTE: When $CPHA = 0$, a $MODF$ occurs if a slave is selected (\overline{SS} is at logic 0) and later unselected (\overline{SS} is at logic 1) even if no SPSCCK is sent to that slave. This happens because \overline{SS} at logic 0 indicates the start of the transmission (MISO driven out with the value of MSB) for $CPHA = 0$. When $CPHA = 1$, a slave can be selected and then later unselected with no transmission occurring. Therefore, $MODF$ does not occur since a transmission was never begun.

In a slave SPI ($MSTR = 0$), the $MODF$ bit generates an SPI receiver/error CPU interrupt request if the $ERRIE$ bit is set. The $MODF$ bit does not clear the SPE bit or reset the SPI in any way. Software can abort the SPI transmission by toggling the SPE bit of the slave.

NOTE: A logic 1 voltage on the \overline{SS} pin of a slave SPI puts the MISO pin in a high impedance state. Also, the slave SPI ignores all incoming SPSCCK clocks, even if a transmission has begun.

To clear the $MODF$ flag, read the $SPSCR$ and then write to the $SPCR$ register. This entire clearing procedure must occur with no $MODF$ condition existing or else the flag will not be cleared.

18.8 Interrupts

The four SPI status flags that can be enabled to generate CPU interrupt requests are listed in [Table 18-3](#).

Table 18-3. SPI Interrupts

Flag	Request
SPTIE (transmitter empty)	SPI transmitter CPU interrupt request ($SPTIE = 1$)
SPRF (receiver full)	SPI receiver CPU interrupt request ($SPRIE = 1$)
OVRF (overflow)	SPI receiver/error interrupt request ($ERRIE = 1$)
MODF (mode fault)	SPI receiver/error interrupt request ($ERRIE = 1, MODFEN = 1$)

The SPI transmitter interrupt enable bit (SPTIE) enables the SPTE flag to generate transmitter CPU interrupt requests.

The SPI receiver interrupt enable bit (SPRIE) enables the SPRF bit to generate receiver CPU interrupt, provided that the SPI is enabled (SPE = 1).

The error interrupt enable bit (ERRIE) enables both the MODF and OVRF flags to generate a receiver/error CPU interrupt request.

The mode fault enable bit (MODFEN) can prevent the MODF flag from being set so that only the OVRF flag is enabled to generate receiver/error CPU interrupt requests.

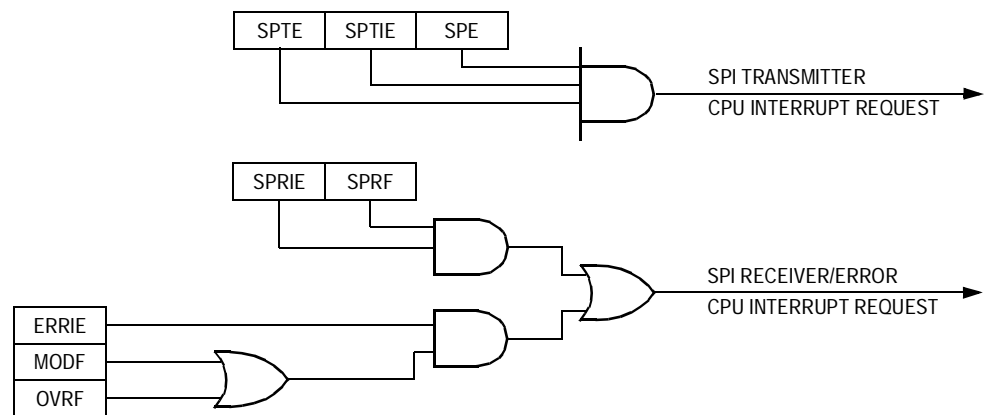

Figure 18-9. SPI Interrupt Request Generation

Two sources in the SPI status and control register can generate CPU interrupt requests:

1. SPI receiver full bit (SPRF) — The SPRF bit becomes set every time a byte transfers from the shift register to the receive data register. If the SPI receiver interrupt enable bit, SPRIE, is also set, SPRF can generate an SPI receiver/error CPU interrupt request.
2. SPI transmitter empty (SPTE) — The SPTE bit becomes set every time a byte transfers from the transmit data register to the shift register. If the SPI transmit interrupt enable bit, SPTIE, is also set, SPTE can generate an SPTE CPU interrupt request.

Serial Peripheral Interface (SPI)

18.9 Queuing Transmission Data

The double-buffered transmit data register allows a data byte to be queued and transmitted. For an SPI configured as a master, a queued data byte is transmitted immediately after the previous transmission has completed. The SPI transmitter empty flag (SPTE in SPSCR) indicates when the transmit data buffer is ready to accept new data. Write to the SPI data register only when the SPTE bit is high. Figure 18-10 shows the timing associated with doing back-to-back transmissions with the SPI (SPSCK has CPHA:CPOL = 1:0).

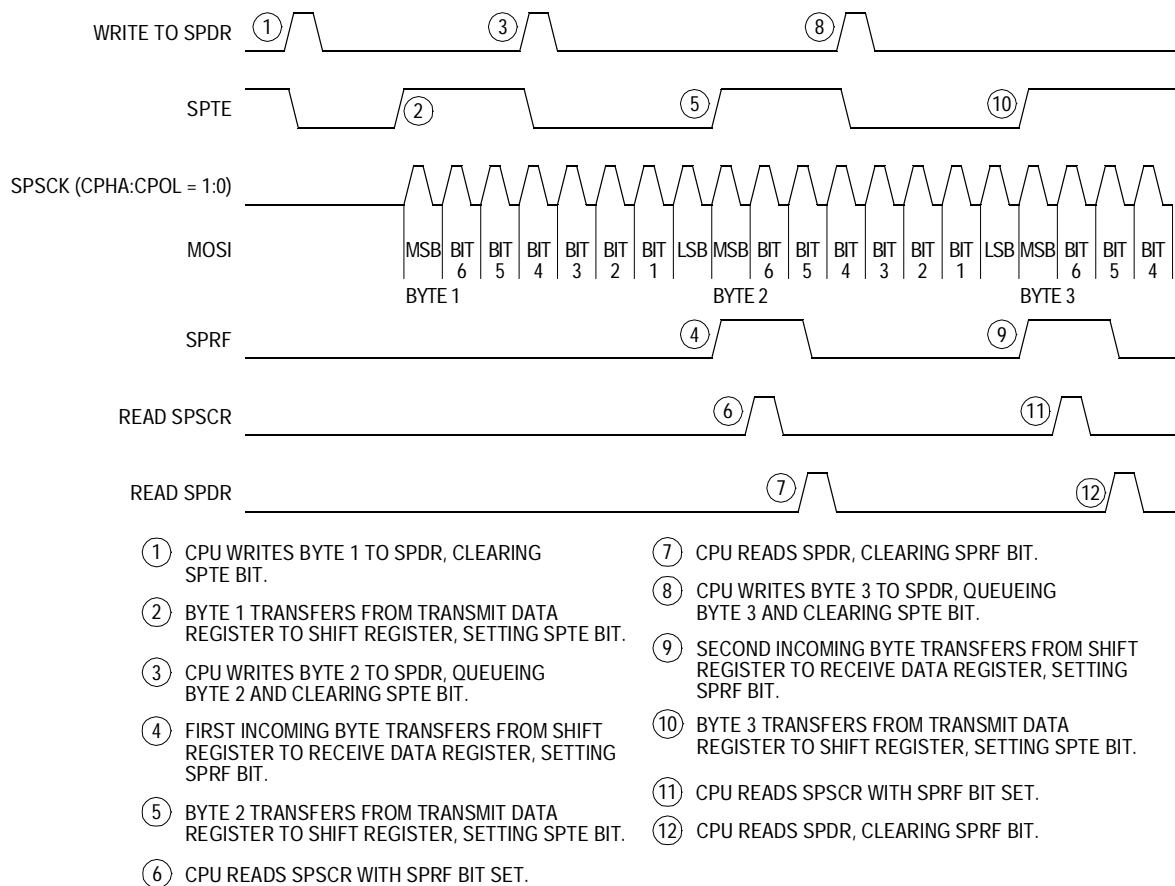

Figure 18-10. SPRF/SPTE CPU Interrupt Timing

For a slave, the transmit data buffer allows back-to-back transmissions to occur without the slave having to time the write of its data between the transmissions. Also, if no new data is written to the data buffer, the last value contained in the shift register will be the next data word transmitted.

18.10 Resetting the SPI

Any system reset completely resets the SPI. Partial reset occurs whenever the SPI enable bit (SPE) is low. Whenever SPE is low, these occur:

- The SPTE flag is set.
- Any transmission currently in progress is aborted.
- The shift register is cleared.
- The SPI state counter is cleared, making it ready for a new complete transmission.
- All the SPI port logic is defaulted back to being general-purpose I/O.

These additional items are reset only by a system reset:

- All control bits in the SPCR register
- All control bits in the SPSCR register (MODFEN, ERRIE, SPR1, and SPR0)
- The status flags SPRF, OVRF, and MODF

By not resetting the control bits when SPE is low, the user can clear SPE between transmissions without having to reset all control bits when SPE is set back to high for the next transmission.

By not resetting the SPRF, OVRF, and MODF flags, the user can still service these interrupts after the SPI has been disabled. The user can disable the SPI by writing 0 to the SPE bit. The SPI also can be disabled by a mode fault occurring in an SPI that was configured as a master with the MODFEN bit set.

18.11 Low-Power Modes

The WAIT and STOP instructions put the MCU in low power-consumption standby modes.

18.11.1 Wait Mode

The SPI module remains active after the execution of a WAIT instruction. In wait mode, the SPI module registers are not accessible by the CPU. Any enabled CPU interrupt request from the SPI module can bring the MCU out of wait mode.

If SPI module functions are not required during wait mode, reduce power consumption by disabling the SPI module before executing the WAIT instruction.

To exit wait mode when an overflow condition occurs, enable the OVRF bit to generate CPU interrupt requests by setting the error interrupt enable bit (ERRIE). (See [18.8 Interrupts](#).)

18.11.2 Stop Mode

The SPI module is inactive after the execution of a STOP instruction. The STOP instruction does not affect register conditions. SPI operation resumes after the MCU exits stop mode. If stop mode is exited by reset, any transfer in progress is aborted and the SPI is reset.

18.12 SPI During Break Interrupts

The system integration module (SIM) controls whether status bits in other modules can be cleared during the break state. The BCFE bit in the SIM break flag control register (SBFCR, \$FE03) enables software to clear status bits during the break state. See [9.8.3 SIM Break Flag Control Register](#).

To allow software to clear status bits during a break interrupt, write a logic 1 to the BCFE bit. If a status bit is cleared during the break state, it remains cleared when the MCU exits the break state.

To protect status bits during the break state, write a logic 0 to the BCFE bit. With BCFE at logic 0 (its default state), software can read and write I/O registers during the break state without affecting status bits. Some status bits have a 2-step read/write clearing procedure. If software does the first step on such a bit before the break, the bit cannot change during the break state as long as BCFE is at logic 0. After the break, doing the second step clears the status bit.

Since the SPTE bit cannot be cleared during a break with the BCFE bit cleared, a write to the data register in break mode will not initiate a transmission nor will this data be transferred into the shift register. Therefore, a write to the SPDR in break mode with the BCFE bit cleared has no effect.

18.13 I/O Signals

The SPI module has four I/O pins and shares three of them with a parallel I/O port.

- MISO — Data received
- MOSI — Data transmitted
- SPCK — Serial clock
- \overline{SS} — Slave select
- V_{SS} — Clock ground

The SPI has limited inter-integrated circuit (I^2C) capability (requiring software support) as a master in a single-master environment. To communicate with I^2C peripherals, MOSI becomes an open-drain output when the SPWOM bit in the SPI control register is set. In I^2C communication, the MOSI and MISO pins are connected to a bidirectional pin from the I^2C peripheral and through a pullup resistor to V_{DD} .

Serial Peripheral Interface (SPI)**18.13.1 MISO (Master In/Slave Out)**

MISO is one of the two SPI module pins that transmit serial data. In full duplex operation, the MISO pin of the master SPI module is connected to the MISO pin of the slave SPI module. The master SPI simultaneously receives data on its MISO pin and transmits data from its MOSI pin.

Slave output data on the MISO pin is enabled only when the SPI is configured as a slave. The SPI is configured as a slave when its SPMSTR bit is logic 0 and its \overline{SS} pin is at logic 0. To support a multiple-slave system, a logic 1 on the \overline{SS} pin puts the MISO pin in a high-impedance state.

When enabled, the SPI controls data direction of the MISO pin regardless of the state of the data direction register of the shared I/O port.

18.13.2 MOSI (Master Out/Slave In)

MOSI is one of the two SPI module pins that transmit serial data. In full duplex operation, the MOSI pin of the master SPI module is connected to the MOSI pin of the slave SPI module. The master SPI simultaneously transmits data from its MOSI pin and receives data on its MISO pin.

When enabled, the SPI controls data direction of the MOSI pin regardless of the state of the data direction register of the shared I/O port.

18.13.3 SPSCCK (Serial Clock)

The serial clock synchronizes data transmission between master and slave devices. In a master MCU, the SPSCCK pin is the clock output. In a slave MCU, the SPSCCK pin is the clock input. In full duplex operation, the master and slave MCUs exchange a byte of data in eight serial clock cycles.

When enabled, the SPI controls data direction of the SPSCCK pin regardless of the state of the data direction register of the shared I/O port.

18.13.4 \overline{SS} (Slave Select)

The \overline{SS} pin has various functions depending on the current state of the SPI. For an SPI configured as a slave, the \overline{SS} is used to select a slave. For CPHA = 0, the \overline{SS} is used to define the start of a transmission. (See [18.6 Transmission Formats](#).) Since it is used to indicate the start of a transmission, the \overline{SS} must be toggled high and low between each byte transmitted for the CPHA = 0 format. However, it can remain low throughout the transmission for the CPHA = 1 format. See [Figure 18-11](#).

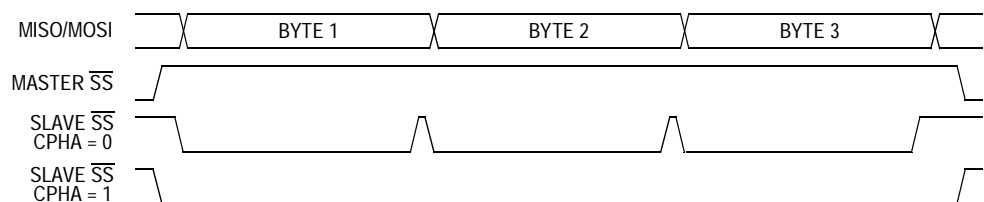
Figure 18-11. CPHA/ \overline{SS} Timing

When an SPI is configured as a slave, the \overline{SS} pin is always configured as an input. It cannot be used as a general-purpose I/O regardless of the state of the MODFEN control bit. However, the MODFEN bit can still prevent the state of the \overline{SS} from creating a MODF error. (See [18.14.2 SPI Status and Control Register](#).)

NOTE: A logic 1 voltage on the \overline{SS} pin of a slave SPI puts the MISO pin in a high-impedance state. The slave SPI ignores all incoming SPSCCK clocks, even if a transmission already has begun.

When an SPI is configured as a master, the \overline{SS} input can be used in conjunction with the MODF flag to prevent multiple masters from driving MOSI and SPSCCK. (See [18.7.2 Mode Fault Error](#).) For the state of the \overline{SS} pin to set the MODF flag, the MODFEN bit in the SPSCCK register must be set. If the MODFEN bit is low for an SPI master, the \overline{SS} pin can be used as a general-purpose I/O under the control of the data direction register of the shared I/O port. With MODFEN high, it is an input-only pin to the SPI regardless of the state of the data direction register of the shared I/O port.

Serial Peripheral Interface (SPI)

The CPU can always read the state of the \overline{SS} pin by configuring the appropriate pin as an input and reading the data register. See [Table 18-4](#).

Table 18-4. SPI Configuration

SPE	SPMSTR	MODFEN	SPI Configuration	State of \overline{SS} Logic
0	X	X	Not enabled	General-purpose I/O; \overline{SS} ignored by SPI
1	0	X	Slave	Input-only to SPI
1	1	0	Master without MODF	General-purpose I/O; \overline{SS} ignored by SPI
1	1	1	Master with MODF	Input-only to SPI

X = Don't care

18.13.5 V_{SS} (Clock Ground)

V_{SS} is the ground return for the serial clock pin, SPSCCK, and the ground for the port output buffers. To reduce the ground return path loop and minimize radio frequency (RF) emissions, connect the ground pin of the slave to the V_{SS} pin.

18.14 I/O Registers

Three registers control and monitor SPI operation:

1. SPI control register (SPCR, \$0010)
2. SPI status and control register (SPSCR, \$0011)
3. SPI data register (SPDR, \$0012)

18.14.1 SPI Control Register

The SPI control register:

- Enables SPI module interrupt requests
- Selects CPU interrupt requests
- Configures the SPI module as master or slave
- Selects serial clock polarity and phase
- Configures the SPCK, MOSI, and MISO pins as open-drain outputs
- Enables the SPI module

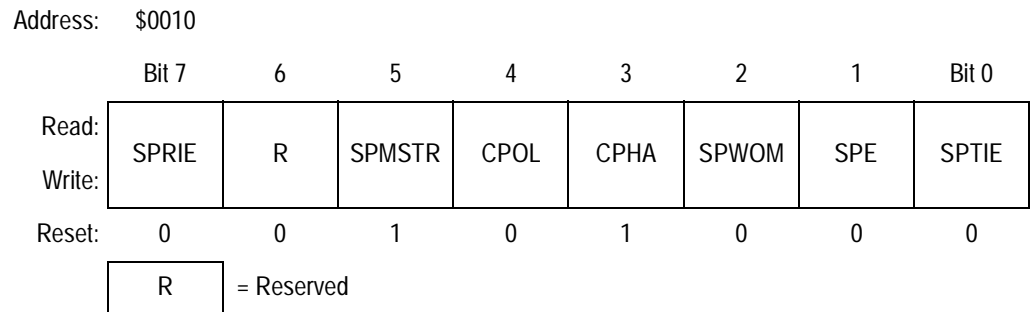

Figure 18-12. SPI Control Register (SPCR)

SPRIE — SPI Receiver Interrupt Enable Bit

This read/write bit enables CPU interrupt requests generated by the SPRF bit. The SPRF bit is set when a byte transfers from the shift register to the receive data register. Reset clears the SPRIE bit.

- 1 = SPRF CPU interrupt requests enabled
- 0 = SPRF CPU interrupt requests disabled

SPMSTR — SPI Master Bit

This read/write bit selects master mode operation or slave mode operation. Reset sets the SPMSTR bit.

- 1 = Master mode
- 0 = Slave mode

Serial Peripheral Interface (SPI)

CPOL — Clock Polarity Bit

This read/write bit determines the logic state of the SPSCCK pin between transmissions. (See [Figure 18-4](#) and [Figure 18-5](#).) To transmit data between SPI modules, the SPI modules must have identical CPOL bits. Reset clears the CPOL bit.

CPHA — Clock Phase Bit

This read/write bit controls the timing relationship between the serial clock and SPI data. (See [Figure 18-4](#) and [Figure 18-5](#).) To transmit data between SPI modules, the SPI modules must have identical CPHA bits. When CPHA = 0, the \overline{SS} pin of the slave SPI module must be set to logic 1 between bytes. (See [Figure 18-11](#).) Reset sets the CPHA bit.

When CPHA = 0 for a slave, the falling edge of \overline{SS} indicates the beginning of the transmission. This causes the SPI to leave its idle state and begin driving the MISO pin with the most significant bit (MSB) of its data. Once the transmission begins, no new data is allowed into the shift register from the data register. Therefore, the slave data register must be loaded with the desired transmit data before the falling edge of \overline{SS} . Any data written after the falling edge is stored in the data register and transferred to the shift register at the current transmission.

When CPHA = 1 for a slave, the first edge of the SPSCCK indicates the beginning of the transmission. The same applies when \overline{SS} is high for a slave. The MISO pin is held in a high-impedance state, and the incoming SPSCCK is ignored. In certain cases, it may also cause the MODF flag to be set. (See [18.7.2 Mode Fault Error](#).) A logic 1 on the \overline{SS} pin does not in any way affect the state of the SPI state machine.

SPWOM — SPI Wired-OR Mode Bit

This read/write bit disables the pullup devices on pins SPSCCK, MOSI, and MISO so that those pins become open-drain outputs.

1 = Wired-OR SPSCCK, MOSI, and MISO pins

0 = Normal push-pull SPSCCK, MOSI, and MISO pins

SPE — SPI Enable Bit

This read/write bit enables the SPI module. Clearing SPE causes a partial reset of the SPI. (See **18.10 Resetting the SPI.**) Reset clears the SPE bit.

- 1 = SPI module enabled
- 0 = SPI module disabled

SPTIE — SPI Transmit Interrupt Enable Bit

This read/write bit enables CPU interrupt requests generated by the SPTIE bit. SPTIE is set when a byte transfers from the transmit data register to the shift register. Reset clears the SPTIE bit.

- 1 = SPTIE CPU interrupt requests enabled
- 0 = SPTIE CPU interrupt requests disabled

18.14.2 SPI Status and Control Register

The SPI status and control register contains flags to signal these conditions:

- Receive data register full
- Failure to clear SPRF bit before next byte is received (overflow error)
- Inconsistent logic level on \overline{SS} pin (mode fault error)
- Transmit data register empty

The SPI status and control register also contains bits that perform these functions:

- Enable error interrupts
- Enable mode fault error detection
- Select master SPI baud rate

Serial Peripheral Interface (SPI)

Address: \$0011

	Bit 7	6	5	4	3	2	1	Bit 0
Read:	SPRF	ERRIE	OVRF	MODF	SPTF	MODFEN	SPR1	SPR0
Write:	R		R	R	R			
Reset:	0	0	0	0	1	0	0	0

R = Reserved

Figure 18-13. SPI Status and Control Register (SPSCR)

SPRF — SPI Receiver Full Bit

This clearable, read-only flag is set each time a byte transfers from the shift register to the receive data register. SPRF generates a CPU interrupt request if the SPRIE bit in the SPI control register is set also. During an SPRF CPU interrupt, the CPU clears SPRF by reading the SPI status and control register with SPRF set and then reading the SPI data register. Any read of the SPI data register clears the SPRF bit.

Reset clears the SPRF bit.

- 1 = Receive data register full
- 0 = Receive data register not full

ERRIE — Error Interrupt Enable Bit

This read-only bit enables the MODF and OVRF flags to generate CPU interrupt requests. Reset clears the ERRIE bit.

- 1 = MODF and OVRF can generate CPU interrupt requests.
- 0 = MODF and OVRF cannot generate CPU interrupt requests.

OVRF — Overflow Bit

This clearable, read-only flag is set if software does not read the byte in the receive data register before the next byte enters the shift register. In an overflow condition, the byte already in the receive data register is unaffected, and the byte that shifted in last is lost. Clear the OVRF bit by reading the SPI status and control register with OVRF set and then reading the SPI data register. Reset clears the OVRF flag.

- 1 = Overflow
- 0 = No overflow

MODF — Mode Fault Bit

This clearable, read-only flag is set in a slave SPI if the \overline{SS} pin goes high during a transmission. In a master SPI, the MODF flag is set if the \overline{SS} pin goes low at any time. Clear the MODF bit by reading the SPI status and control register with MODF set and then writing to the SPI status and control register. Reset clears the MODF bit.

1 = \overline{SS} pin at inappropriate logic level

0 = \overline{SS} pin at appropriate logic level

SPTIE — SPI Transmitter Empty Bit

This clearable, read-only flag is set each time the transmit data register transfers a byte into the shift register. SPTIE generates an SPTIE CPU interrupt request if the SPTIE bit in the SPI control register is set also.

NOTE: *Do not write to the SPI data register unless the SPTIE bit is high.*

For an idle master or idle slave that has no data loaded into its transmit buffer, the SPTIE will be set again within two bus cycles since the transmit buffer empties into the shift register. This allows the user to queue up a 16-bit value to send. For an already active slave, the load of the shift register cannot occur until the transmission is completed. This implies that a back-to-back write to the transmit data register is not possible. The SPTIE indicates when the next write can occur.

Reset sets the SPTIE bit.

1 = Transmit data register empty

0 = Transmit data register not empty

MODFEN — Mode Fault Enable Bit

This read/write bit, when set to 1, allows the MODF flag to be set. If the MODF flag is set, clearing the MODFEN does not clear the MODF flag. If the SPI is enabled as a master and the MODFEN bit is low, then the \overline{SS} pin is available as a general-purpose I/O.

If the MODFEN bit is set, then this pin is not available as a general-purpose I/O. When the SPI is enabled as a slave, the \overline{SS} pin is not available as a general-purpose I/O regardless of the value of MODFEN. (See [18.13.4 SS \(Slave Select\)](#).)

Serial Peripheral Interface (SPI)

If the MODFEN bit is low, the level of the \overline{SS} pin does not affect the operation of an enabled SPI configured as a master. For an enabled SPI configured as a slave, having MODFEN low only prevents the MODF flag from being set. It does not affect any other part of SPI operation. (See [18.7.2 Mode Fault Error](#).)

SPR1 and SPR0 — SPI Baud Rate Select Bits

In master mode, these read/write bits select one of four baud rates as shown in [Table 18-5](#). SPR1 and SPR0 have no effect in slave mode. Reset clears SPR1 and SPR0.

Table 18-5. SPI Master Baud Rate Selection

SPR1:SPR0	Baud Rate Divisor (BD)
00	2
01	8
10	32
11	128

Use this formula to calculate the SPI baud rate:

$$\text{Baud rate} = \frac{\text{CGMOUT}}{2 \times \text{BD}}$$

where:

CGMOUT = base clock output of the clock generator module (CGM); see [Section 10. Clock Generator Module \(CGM\)](#)

BD = baud rate divisor

18.14.3 SPI Data Register

The SPI data register is the read/write buffer for the receive data register and the transmit data register. Writing to the SPI data register writes data into the transmit data register. Reading the SPI data register reads data from the receive data register. The transmit data and receive data registers are separate buffers that can contain different values. See [Figure 18-2](#).

Address: \$0012

	Bit 7	6	5	4	3	2	1	Bit 0
Read:	R7	R6	R5	R4	R3	R2	R1	R0
Write:	T7	T6	T5	T4	T3	T2	T1	T0
Reset:	Indeterminate after reset							

Figure 18-14. SPI Data Register (SPDR)

R7–R0/T7–T0 — Receive/Transmit Data Bits

NOTE: *Do not use read-modify-write instructions on the SPI data register since the buffer read is not the same as the buffer written.*

Section 19. Modulo Timer (TIM)

19.1 Contents

19.2	Introduction	291
19.3	Features	292
19.4	Functional Description	292
19.5	TIM Counter Prescaler	294
19.6	Low-Power Modes	294
19.6.1	Wait Mode	294
19.6.2	Stop Mode	294
19.7	TIM During Break Interrupts	295
19.8	I/O Registers	295
19.8.1	TIM Status and Control Register	296
19.8.2	TIM Counter Registers	298
19.8.3	TIM Counter Modulo Registers	299

19.2 Introduction

This section describes the modulo timer (TIM) which is a periodic interrupt timer whose counter is clocked internally via software programmable options. **Figure 19-1** is a block diagram of the TIM.

Modulo Timer (TIM)

19.3 Features

Features of the TIM include:

- Programmable TIM clock input
- Free-running or modulo up-count operation
- TIM counter stop and reset bits

19.4 Functional Description

Figure 19-1 shows the structure of the TIM. The central component of the TIM is the 16-bit TIM counter that can operate as a free-running counter or a modulo up-counter. The counter provides the timing reference for the interrupt. The TIM counter modulo registers, TMODH–TMODL, control the modulo value of the counter. Software can read the counter value at any time without affecting the counting sequence.

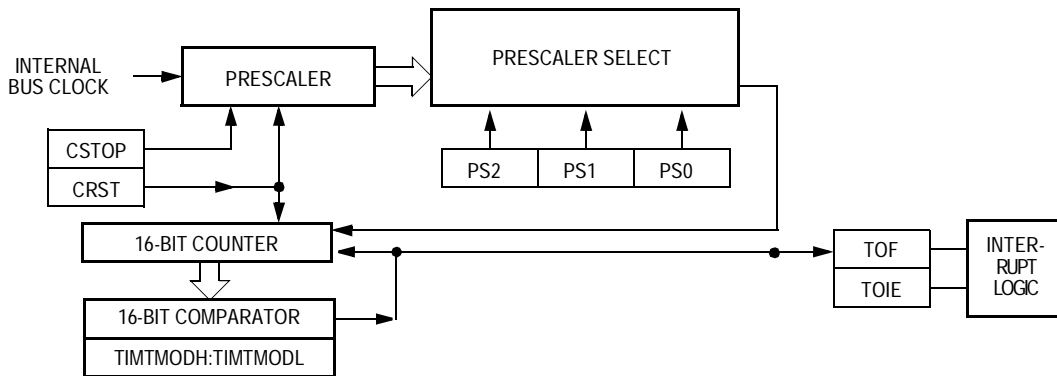

Figure 19-1. TIM Block Diagram

Addr.	Register Name	Bit 7	6	5	4	3	2	1	Bit 0	
\$004B	TIM Status and Control Register (TSC) See page 296.	Read:	TOF	TOIE	TSTOP	0	0	PS2	PS1	PS0
		Write:	0			TRST				
		Reset:	0	0	1	0	0	0	0	0
\$004C	TIM Counter Register High (TCNTH) See page 298.	Read:	Bit 15	14	13	12	11	10	9	Bit 8
		Write:								
		Reset:	0	0	0	0	0	0	0	0
\$004D	TIM Counter Register Low (TCNTL) See page 298.	Read:	Bit 7	6	5	4	3	2	1	Bit 0
		Write:								
		Reset:	0	0	0	0	0	0	0	0
\$004E	TIM Modulo Register High (TMODH) See page 299.	Read:	Bit 15	14	13	12	11	10	9	Bit 8
		Write:								
		Reset:	1	1	1	1	1	1	1	1
\$004F	TIM Modulo Register Low (TMDL) See page 299.	Read:	Bit 7	6	5	4	3	2	1	Bit 0
		Write:								
		Reset:	1	1	1	1	1	1	1	1

= Unimplemented
 R = Reserved

Figure 19-2. TIM I/O Register Summary

19.5 TIM Counter Prescaler

The clock source can be one of the seven prescaler outputs. The prescaler generates seven clock rates from the internal bus clock. The prescaler select bits, PS2–PS0, in the status and control register select the TIM clock source.

The value in the TIM counter modulo registers and the selected prescaler output determines the frequency of the periodic interrupt. The TIM overflow flag (TOF) is set when the TIM counter value rolls over to \$0000 after matching the value in the TIM counter modulo registers. The TIM interrupt enable bit, TOIE, enables TIM overflow CPU interrupt requests. TOF and TOIE are in the TIM status and control register.

19.6 Low-Power Modes

The WAIT and STOP instructions put the MCU in low power-consumption standby modes.

19.6.1 Wait Mode

The TIM remains active after the execution of a WAIT instruction. In wait mode the TIM registers are not accessible by the CPU. Any enabled CPU interrupt request from the TIM can bring the MCU out of wait mode.

If TIM functions are not required during wait mode, reduce power consumption by stopping the TIM before executing the WAIT instruction.

19.6.2 Stop Mode

The TIM is inactive after the execution of a STOP instruction. The STOP instruction does not affect register conditions or the state of the TIM counter. TIM operation resumes when the MCU exits stop mode after an external interrupt.

19.7 TIM During Break Interrupts

A break interrupt stops the TIM counter.

The system integration module (SIM) controls whether status bits in other modules can be cleared during the break state. The BCFE bit in the SIM break flag control register (SBFCR) enables software to clear status bits during the break state. (See [9.8.3 SIM Break Flag Control Register](#).)

To allow software to clear status bits during a break interrupt, write a logic 1 to the BCFE bit. If a status bit is cleared during the break state, it remains cleared when the MCU exits the break state.

To protect status bits during the break state, write a logic 0 to the BCFE bit. With BCFE at logic 0 (its default state), software can read and write I/O registers during the break state without affecting status bits. Some status bits have a 2-step read/write clearing procedure. If software does the first step on such a bit before the break, the bit cannot change during the break state as long as BCFE is at logic 0. After the break, doing the second step clears the status bit.

19.8 I/O Registers

These I/O registers control and monitor operation of the TIM:

- TIM status and control register (TSC)
- TIM counter registers (TCNTH–TCNTL)
- TIM counter modulo registers (TMODH–TMODL)

19.8.1 TIM Status and Control Register

The TIM status and control register:

- Enables TIM interrupt
- Flags TIM overflows
- Stops the TIM counter
- Resets the TIM counter
- Prescales the TIM counter clock

Address: \$004B

	Bit 7	6	5	4	3	2	1	Bit 0
Read:	TOF	TOIE	TSTOP	0	0	PS2	PS1	PS0
Write:	0			TRST				
Reset:	0	0	1	0	0	0	0	0

 = Unimplemented

Figure 19-3. TIM Status and Control Register (TSC)

TOF — TIM Overflow Flag Bit

This read/write flag is set when the TIM counter resets to \$0000 after reaching the modulo value programmed in the TIM counter modulo registers. Clear TOF by reading the TIM status and control register when TOF is set and then writing a logic 0 to TOF. If another TIM overflow occurs before the clearing sequence is complete, then writing logic 0 to TOF has no effect. Therefore, a TOF interrupt request cannot be lost due to inadvertent clearing of TOF. Reset clears the TOF bit. Writing a logic 1 to TOF has no effect.

- 1 = TIM counter has reached modulo value.
- 0 = TIM counter has not reached modulo value.

TOIE — TIM Overflow Interrupt Enable Bit

This read/write bit enables TIM overflow interrupts when the TOF bit becomes set. Reset clears the TOIE bit.

- 1 = TIM overflow interrupts enabled
- 0 = TIM overflow interrupts disabled

TSTOP — TIM Stop Bit

This read/write bit stops the TIM counter. Counting resumes when TSTOP is cleared. Reset sets the TSTOP bit, stopping the TIM counter until software clears the TSTOP bit.

- 1 = TIM counter stopped
- 0 = TIM counter active

NOTE: Do not set the TSTOP bit before entering wait mode if the TIM is required to exit wait mode.

TRST — TIM Reset Bit

Setting this write-only bit resets the TIM counter and the TIM prescaler. Setting TRST has no effect on any other registers. Counting resumes from \$0000. TRST is cleared automatically after the TIM counter is reset and always reads as logic 0. Reset clears the TRST bit.

- 1 = Prescaler and TIM counter cleared
- 0 = No effect

NOTE: Setting the TSTOP and TRST bits simultaneously stops the TIM counter at a value of \$0000.

PS2–PS0 — Prescaler Select Bits

These read/write bits select one of the seven prescaler outputs as the input to the TIM counter as Table 19-1 shows. Reset clears the PS2–PS0 bits.

Table 19-1. Prescaler Selection

PS2–PS0	TIM Clock Source
000	Internal bus clock ÷ 1
001	Internal bus clock ÷ 2
010	Internal bus clock ÷ 4
011	Internal bus clock ÷ 8
100	Internal bus clock ÷ 16
101	Internal bus clock ÷ 32
110	Internal bus clock ÷ 64
111	Internal bus clock ÷ 64

Modulo Timer (TIM)

19.8.2 TIM Counter Registers

The two read-only TIM counter registers contain the high and low bytes of the value in the TIM counter. Reading the high byte (TCNTH) latches the contents of the low byte (TCNTL) into a buffer. Subsequent reads of TCNTH do not affect the latched TCNTL value until TCNTL is read. Reset clears the TIM counter registers. Setting the TIM reset bit (TRST) also clears the TIM counter registers.

NOTE: *If TCNTH is read during a break interrupt, be sure to unlatch TCNTL by reading TCNTL before exiting the break interrupt. Otherwise, TCNTL retains the value latched during the break.*

Address: \$004C

	Bit 7	6	5	4	3	2	1	Bit 0
Read:	Bit 15	14	13	12	11	10	9	Bit 8
Write:								
Reset:	0	0	0	0	0	0	0	0

Address: \$004D

	Bit 7	6	5	4	3	2	1	Bit 0
Read:	Bit 7	6	5	4	3	2	1	Bit 0
Write:								
Reset:	0	0	0	0	0	0	0	0

 = Unimplemented

Figure 19-4. TIM Counter Registers (TCNTH–TCNTL)

19.8.3 TIM Counter Modulo Registers

The read/write TIM modulo registers contain the modulo value for the TIM counter. When the TIM counter reaches the modulo value, the overflow flag (TOF) becomes set, and the TIM counter resumes counting from \$0000 at the next clock. Writing to the high byte (TMODH) inhibits the TOF bit and overflow interrupts until the low byte (TMODL) is written. Reset sets the TIM counter modulo registers.

Address: \$004E

	Bit 7	6	5	4	3	2	1	Bit 0
Read:	Bit 15	14	13	12	11	10	9	Bit 8
Write:								
Reset:	1	1	1	1	1	1	1	1

Address: \$004F

	Bit 7	6	5	4	3	2	1	Bit 0
Read:	Bit 7	6	5	4	3	2	1	Bit 0
Write:								
Reset:	1	1	1	1	1	1	1	1

Figure 19-5. TIM Counter Modulo Registers (TMODH–TMODL)

NOTE: Reset the TIM counter before writing to the TIM counter modulo registers.

Section 20. Input/Output (I/O) Ports

20.1 Contents

20.2	Introduction	302
20.3	Port A	304
20.3.1	Port A Data Register	304
20.3.2	Data Direction Register A	304
20.4	Port B	306
20.4.1	Port B Data Register	306
20.4.2	Data Direction Register B	307
20.5	Port C	308
20.5.1	Port C Data Register	308
20.5.2	Data Direction Register C	309
20.6	Port D	311
20.6.1	Port D Data Register	311
20.6.2	Data Direction Register D	312
20.7	Port E	314
20.7.1	Port E Data Register	314
20.7.2	Data Direction Register E	316
20.8	Port F	318
20.8.1	Port F Data Register	318
20.8.2	Data Direction Register F	319
20.9	Port G	320
20.9.1	Port G Data Register	320
20.9.2	Data Direction Register G	321
20.10	Port H	323
20.10.1	Port H Data Register	323
20.10.2	Data Direction Register H	324

Input/Output (I/O) Ports

20.2 Introduction

Forty bidirectional input/output (I/O) pins form six parallel ports. All I/O pins are programmable as inputs or outputs.

NOTE: Connect any unused I/O pins to an appropriate logic level, either V_{DD} or V_{SS} . Although the I/O ports do not require termination for proper operation, termination reduces excess current consumption and the possibility of electrostatic damage.

Addr.	Register Name	Bit 7	6	5	4	3	2	1	Bit 0	
\$0000	Port A Data Register (PTA) See page 304.	Read:	PTA7	PTA6	PTA5	PTA4	PTA3	PTA2	PTA1	PTA0
		Write:								
		Reset:	Unaffected by reset							
\$0001	Port B Data Register (PTB) See page 306.	Read:	PTB7	PTB6	PTB5	PTB4	PTB3	PTB2	PTB1	PTB0
		Write:								
		Reset:	Unaffected by reset							
\$0002	Port C Data Register (PTC) See page 308.	Read:	0	0	PTC5	PTC4	PTC3	PTC2	PTC1	PTC0
		Write:	R	R						
		Reset:	Unaffected by reset							
\$0003	Port D Data Register (PTD) See page 311.	Read:	PTD7	PTD6	PTD5	PTD4	PTD3	PTD2	PTD1	PTD0
		Write:								
		Reset:	Unaffected by reset							
\$0004	Data Direction Register A (DDRA) See page 304.	Read:	DDRA7	DDRA6	DDRA5	DDRA4	DDRA3	DDRA2	DDRA1	DDRA0
		Write:								
		Reset:	Unaffected by reset							
\$0005	Data Direction Register B (DDRB) See page 307.	Read:	DDRB7	DDRB6	DDRB5	DDRB4	DDRB3	DDRB2	DDRB1	DDRB0
		Write:								
		Reset:	0	0	0	0	0	0	0	0
\$0006	Data Direction Register C (DDRC) See page 309.	Read:	MCLKEN	0	DDRC5	DDRC4	DDRC3	DDRC2	DDRC1	DDRC0
		Write:		R						
		Reset:	0	0	0	0	0	0	0	0

R = Reserved

Figure 20-1. I/O Port Register Summary

Addr.	Register Name	Bit 7	6	5	4	3	2	1	Bit 0	
\$0007	Data Direction Register D (DDR) See page 312.	Read:	DDR7	DDR6	DDR5	DDR4	DDR3	DDR2	DDR1	DDR0
		Write:								
		Reset:	0	0	0	0	0	0	0	0
\$0008	Port E Data Register (PTE) See page 314.	Read:	PTE7	PTE6	PTE5	PTE4	PTE3	PTE2	PTE1	PTE0
		Write:								
		Reset:	Unaffected by reset							
\$0009	Port F Data Register (PTF) See page 318.	Read:	0	PTF6	PTF5	PTF4	PTF3	PTF2	PTF1	PTF0
		Write:	R							
		Reset:	Unaffected by reset							
\$000A	Port G Data Register (PTG) ⁽¹⁾ See page 320.	Read:	0	0	0	0	0	PTG2	PTG1	PTG0
		Write:	R	R	R	R	R			
		Reset:	Unaffected by reset							
\$000B	Port H Data Register (PTH) ⁽¹⁾ See page 323.	Read:	0	0	0	0	0	0	PTH1	PTH0
		Write:	R	R	R	R	R	R		
		Reset:	Unaffected by reset							
\$000C	Data Direction Register E (DDRE) See page 316.	Read:	DDRE7	DDRE6	DDRE5	DDRE4	DDRE3	DDRE2	DDRE1	DDRE0
		Write:								
		Reset:	0	0	0	0	0	0	0	0
\$000D	Data Direction Register F (DDRF) See page 319.	Read:	0	DDRF6	DDRF5	DDRF4	DDRF3	DDRF2	DDRF1	DDRF0
		Write:	R							
		Reset:	0	0	0	0	0	0	0	0
\$000E	Data Direction Register G (DDRG) ⁽¹⁾ See page 321.	Read:	0	0	0	0	0	DDRG2	DDRG1	DDRG0
		Write:	R	R	R	R	R			
		Reset:	0	0	0	0	0	0	0	0
\$000F	Data Direction Register H (DDRH) ⁽¹⁾ See page 324.	Read:	0	0	0	0	0	0	DDRH1	DDRH0
		Write:	R	R	R	R	R	R		
		Reset:	0	0	0	0	0	0	0	0

1. The pins associated with port G and port H are available only in the 64-pin quad flat pack (QFP).

R

 = Reserved

Figure 20-1. I/O Port Register Summary (Continued)

20.3 Port A

Port A is an 8-bit, general-purpose, bidirectional I/O port.

20.3.1 Port A Data Register

The port A data register (PTA) contains a data latch for each of the eight port A pins.

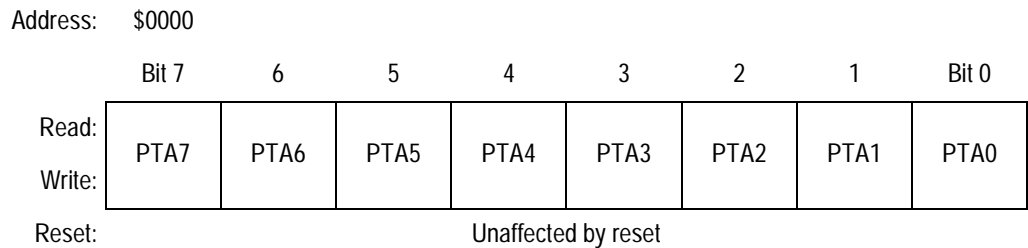

Figure 20-2. Port A Data Register (PTA)

PTA[7:0] — Port A Data Bits

These read/write bits are software programmable. Data direction of each port A pin is under the control of the corresponding bit in data direction register A. Reset has no effect on port A data.

20.3.2 Data Direction Register A

Data direction register A (DDRA) determines whether each port A pin is an input or an output. Writing a logic 1 to a DDRA bit enables the output buffer for the corresponding port A pin; a logic 0 disables the output buffer.

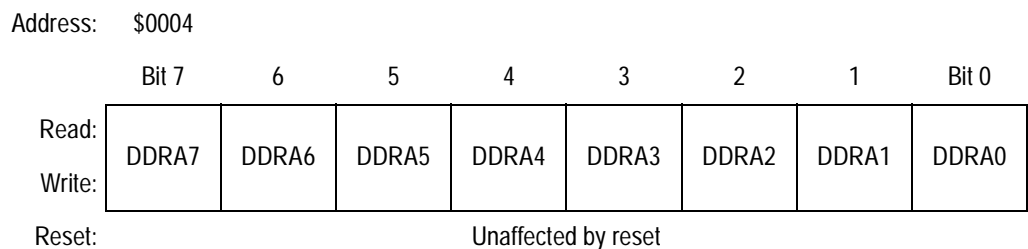

Figure 20-3. Data Direction Register A (DDRA)

DDRA[7:0] — Data Direction Register A Bits

These read/write bits control port A data direction. Reset clears DDRA[7:0], configuring all port A pins as inputs.

- 1 = Corresponding port A pin configured as output
- 0 = Corresponding port A pin configured as input

NOTE: Avoid glitches on port A pins by writing to the port A data register before changing data direction register A bits from 0 to 1.

Figure 20-4 shows the port A I/O logic.

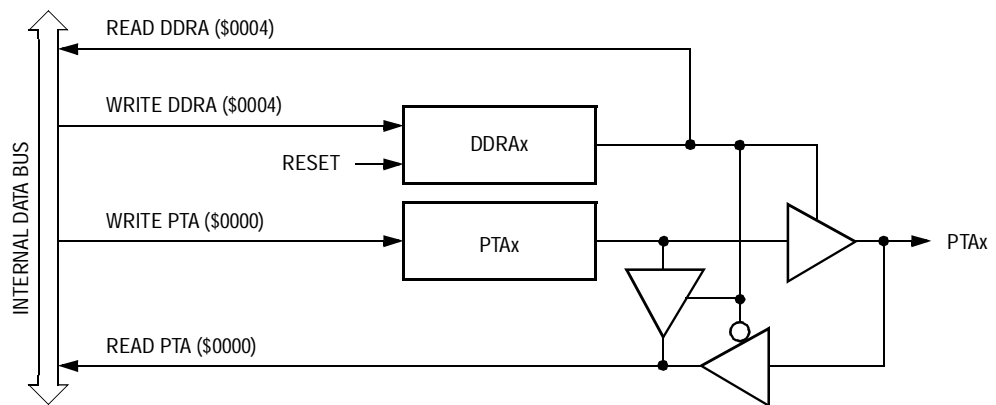

Figure 20-4. Port A I/O Circuit

When bit DDRAx is a logic 1, reading address \$0000 reads the PTAx data latch. When bit DDRAx is a logic 0, reading address \$0000 reads the voltage level on the pin. The data latch can always be written, regardless of the state of its data direction bit. Table 20-1 summarizes the operation of the port A pins.

Table 20-1. Port A Pin Functions

DDRA Bit	PTA Bit	I/O Pin Mode	Accesses to DDRA		
			Read/Write	Read	Write
0	X	Input, Hi-Z	DDRA[7:0]	Pin	PTA[7:0] ⁽¹⁾
1	X	Output	DDRA[7:0]	PTA[7:0]	PTA[7:0]

X = Don't care

Hi-Z = High impedance

1. Writing affects data register, but does not affect input.

20.4 Port B

Port B is an 8-bit special-function port that shares all of its pins with the analog-to-digital converter (ADC).

20.4.1 Port B Data Register

The port B data register (PTB) contains a data latch for each of the eight port B pins.

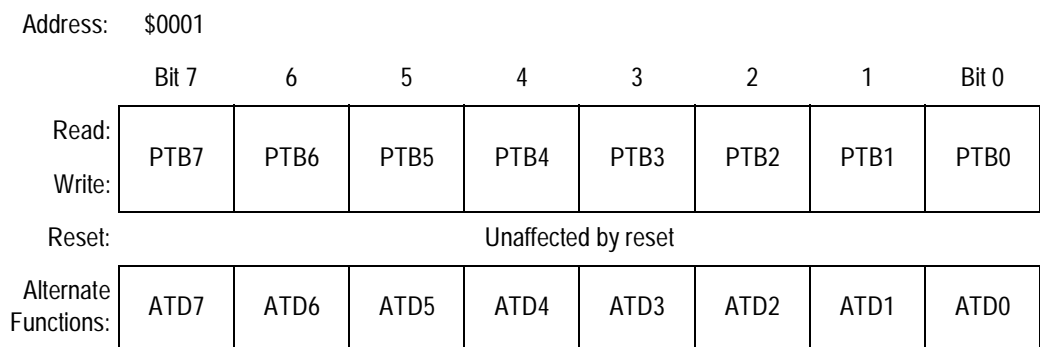

Figure 20-5. Port B Data Register (PTB)

PTB[7:0] — Port B Data Bits

These read/write bits are software programmable. Data direction of each port B pin is under the control of the corresponding bit in data direction register B. Reset has no effect on port B data.

ATD[7:0] — ADC Channels

PTB7/ATD7–PTB0/ATD0 are eight of the 15 analog-to-digital converter channels. The ADC channel select bits, CH[4:0], determine whether the PTB7/ATD7–PTB0/ATD0 pins are ADC channels or general-purpose I/O pins. If an ADC channel is selected and a read of this corresponding bit in the port B data register occurs, the data will be 0 if the data direction for this bit is programmed as an input. Otherwise, the data will reflect the value in the data latch. Data direction register B (DDRB) does not affect the data direction of port B pins that are being used by the ADC. However, the DDRB bits always determine whether reading port B returns to the states of the latches or logic 0. See [Section 23. Analog-to-Digital Converter \(ADC-15\)](#).

20.4.2 Data Direction Register B

Data direction register B (DDRB) determines whether each port B pin is an input or an output. Writing a logic 1 to a DDRB bit enables the output buffer for the corresponding port B pin; a logic 0 disables the output buffer.

Address: \$0005

	Bit 7	6	5	4	3	2	1	Bit 0
Read:	DDRB7	DDRB6	DDRB5	DDRB4	DDRB3	DDRB2	DDRB1	DDRB0
Write:								
Reset:	0	0	0	0	0	0	0	0

Figure 20-6. Data Direction Register B (DDRB)

DDRB[7:0] — Data Direction Register B Bits

These read/write bits control port B data direction. Reset clears DDRB[7:0], configuring all port B pins as inputs.

- 1 = Corresponding port B pin configured as output
- 0 = Corresponding port B pin configured as input

NOTE: Avoid glitches on port B pins by writing to the port B data register before changing data direction register B bits from 0 to 1.

Figure 20-7 shows the port B I/O logic.

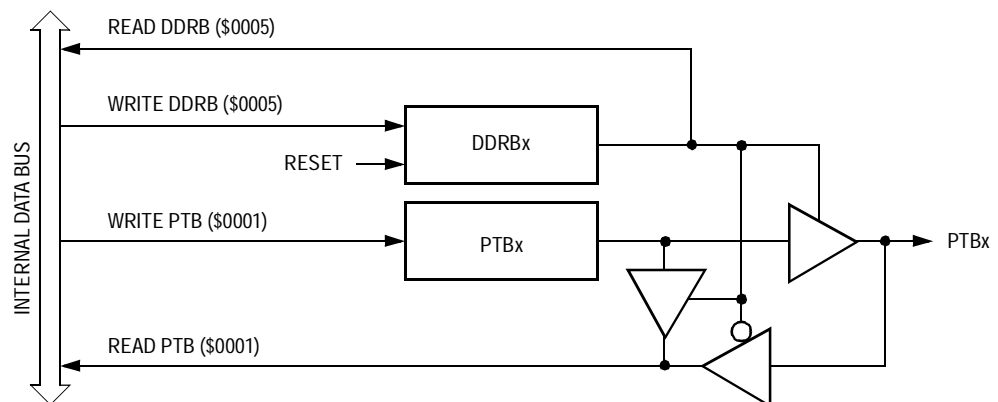

Figure 20-7. Port B I/O Circuit

When bit DDRBx is a logic 1, reading address \$0001 reads the PTBx data latch. When bit DDRBx is a logic 0, reading address \$0001 reads the voltage level on the pin. The data latch can always be written, regardless of the state of its data direction bit. **Table 20-2** summarizes the operation of the port B pins.

Table 20-2. Port B Pin Functions

DDRB Bit	PTB Bit	I/O Pin Mode	Accesses to DDRB	Accesses to PTB	
			Read/Write	Read	Write
0	X	Input, Hi-Z	DDRB[7:0]	Pin	PTB[7:0] ⁽¹⁾
1	X	Output	DDRB[7:0]	PTB[7:0]	PTB[7:0]

X = Don't care

Hi-Z = High impedance

1. Writing affects data register, but does not affect input.

20.5 Port C

Port C is a 6-bit, general-purpose, bidirectional I/O port.

20.5.1 Port C Data Register

The port C data register (PTC) contains a data latch for each of the five port C pins.

NOTE: *The pin associated with PTC5 is available only in the 64-pin quad flat pack (QFP).*

Address: \$0002

	Bit 7	6	5	4	3	2	1	Bit 0
Read:	0	0	PTC5	PTC4	PTC3	PTC2	PTC1	PTC0
Write:	R	R						
Reset:	Unaffected by reset							
Alternate Functions:	R	R	R	R	R	MCLK	R	R

R = Reserved

Figure 20-8. Port C Data Register (PTC)

PTC[5:0] — Port C Data Bits

These read/write bits are software-programmable. Data direction of each port C pin is under the control of the corresponding bit in data direction register C. Reset has no effect on port C data.

MCLK — T12 System Clock Bit

The system clock is driven out of PTC2 when enabled by MCLKEN bit in PTCDDR7.

20.5.2 Data Direction Register C

Data direction register C (DDRC) determines whether each port C pin is an input or an output. Writing a logic 1 to a DDRC bit enables the output buffer for the corresponding port C pin; a logic 0 disables the output buffer.

Address: \$0006

	Bit 7	6	5	4	3	2	1	Bit 0
Read:	MCLKEN	0	DDRC5	DDRC4	DDRC3	DDRC2	DDRC1	DDRC0
Write:	MCLKEN	R	DDRC5	DDRC4	DDRC3	DDRC2	DDRC1	DDRC0
Reset:	0	0	0	0	0	0	0	0

R = Reserved

Figure 20-9. Data Direction Register C (DDRC)

MCLKEN — MCLK Enable Bit

This read/write bit enables MCLK to be an output signal on PTC2. If MCLK is enabled, PTC2 is under the control of MCLKEN. Reset clears this bit.

- 1 = MCLK output enabled
- 0 = MCLK output disabled

DDRC[5:0] — Data Direction Register C Bits

These read/write bits control port C data direction. Reset clears DDRC[7:0], configuring all port C pins as inputs.

- 1 = Corresponding port C pin configured as output
- 0 = Corresponding port C pin configured as input

Input/Output (I/O) Ports

NOTE: Avoid glitches on port C pins by writing to the port C data register before changing data direction register C bits from 0 to 1.

Figure 20-10 shows the port C I/O logic.

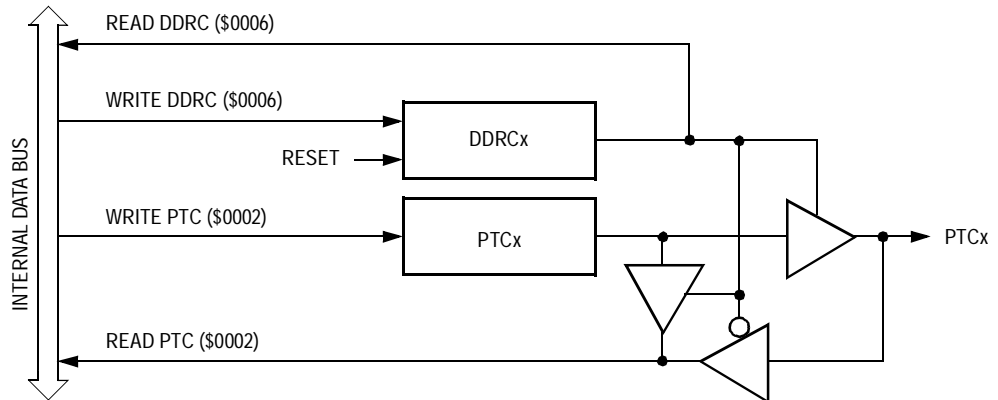

Figure 20-10. Port C I/O Circuit

When bit DDRCx is a logic 1, reading address \$0002 reads the PTCx data latch. When bit DDRCx is a logic 0, reading address \$0002 reads the voltage level on the pin. The data latch can always be written, regardless of the state of its data direction bit. Table 20-3 summarizes the operation of the port C pins.

Table 20-3. Port C Pin Functions

DDRC Bit	PTC Bit	I/O Pin Mode	Accesses to DDRC	Accesses to PTC	
			Read/Write	Read	Write
0	2	Input, Hi-Z	DDRC[5:0]	Pin	PTC2
1	2	Output	DDRC[5:0]	0	—
0	X	Input, Hi-Z	DDRC[5:0]	Pin	PTC[5:0] ⁽¹⁾
1	X	Output	DDRC[5:0]	PTC[5:0]	PTC[5:0]

X = Don't care

Hi-Z = High impedance

1. Writing affects data register, but does not affect input.

20.6 Port D

Port D is an 8-bit general-purpose I/O port.

NOTE: The pin associated with PTD7 is available only in the 64-pin QFP.

20.6.1 Port D Data Register

Port D is an 8-bit special function port that shares all of its pins with the analog-to-digital converter and one of its pins with the timer interface module A (TIMA).

Address: \$0003

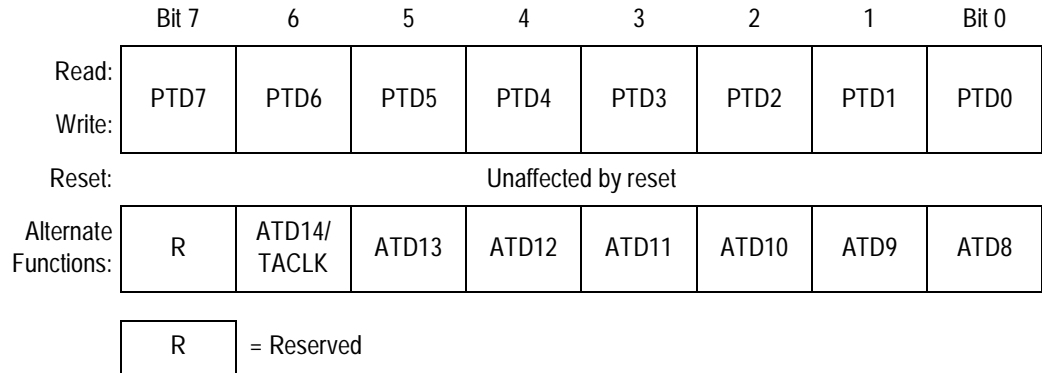

Figure 20-11. Port D Data Register (PTD)

PTD[7:0] — Port D Data Bits

PTD[7:0] are read/write, software programmable bits. Data direction of PTD[7:0] pins are under the control of the corresponding bit in data direction register D.

ATD[14:8] — ADC Channel Status Bits

PTD6/TACLK–PTD0 are seven of the 15 analog-to-digital converter channels. The ADC channel select bits, CH[4:0], determine whether the PTD6/TACLK–PTD0 pins are ADC channels or general-purpose I/O pins. If an ADC channel is selected and a read of this corresponding bit in the port B data register occurs, the data will be 0 if the data direction for this bit is programmed as an input. Otherwise, the data will reflect the value in the data latch. See [Section 23. Analog-to-Digital Converter \(ADC-15\)](#).

NOTE: Data direction register D (DDRD) does not affect the data direction of port D pins that are being used by the ADC. However, the DDRD bits always determine whether reading port D returns the states of the latches or logic 0.

TACLK — Timer Clock Input Bit

The PTD6/TACLK pin is the external clock input for the TIMA. The prescaler select bits, PS[2:0], select PTD6/TACLK as the TIMA clock input. (See [22.9.1 TIMA Status and Control Register](#).) When not selected as the TIMA clock, PTD6/TACLK is available for general-purpose I/O or as an ADC channel.

NOTE: Do not use ADC channel ATD14 when using the PTD6/TACLK pin as the clock input for the TIMA.

20.6.2 Data Direction Register D

Data direction register D (DDRD) determines whether each port D pin is an input or an output. Writing a logic 1 to a DDRD bit enables the output buffer for the corresponding port D pin; a logic 0 disables the output buffer.

Address: \$0007

	Bit 7	6	5	4	3	2	1	Bit 0
Read:								
Write:	DDRD7	DDRD6	DDRD5	DDRD4	DDRD3	DDRD2	DDRD1	DDRD0
Reset:	0	0	0	0	0	0	0	0

Figure 20-12. Data Direction Register D (DDRD)

DDRD[7:0] — Data Direction Register D Bits

These read/write bits control port D data direction. Reset clears DDRD[7:0], configuring all port D pins as inputs.

1 = Corresponding port D pin configured as output

0 = Corresponding port D pin configured as input

NOTE: Avoid glitches on port D pins by writing to the port D data register before changing data direction register D bits from 0 to 1.

Figure 20-13 shows the port D I/O logic.

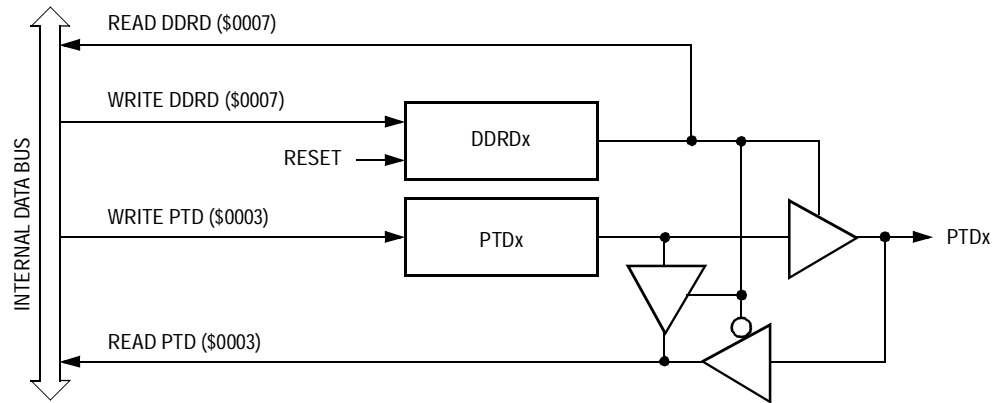

Figure 20-13. Port D I/O Circuit

When bit DDRDx is a logic 1, reading address \$0003 reads the PTDx data latch. When bit DDRDx is a logic 0, reading address \$0003 reads the voltage level on the pin. The data latch can always be written, regardless of the state of its data direction bit. Table 20-4 summarizes the operation of the port D pins.

Table 20-4. Port D Pin Functions

DDRD Bit	PTD Bit	I/O Pin Mode	Accesses to DDRD	Accesses to PTD	
			Read/Write	Read	Write
0	X	Input, Hi-Z	DDRD[7:0]	Pin	PTD[7:0] ⁽¹⁾
1	X	Output	DDRD[7:0]	PTD[7:0]	PTD[7:0]

X = Don't care

Hi-Z = High impedance

1. Writing affects data register, but does not affect input.

20.7 Port E

Port E is an 8-bit special function port that shares two of its pins with the timer interface module (TIMA), two of its pins with the serial communications interface module (SCI), and four of its pins with the serial peripheral interface module (SPI).

20.7.1 Port E Data Register

The port E data register (PTE) contains a data latch for each of the eight port E pins.

Address: \$0008

	Bit 7	6	5	4	3	2	1	Bit 0
Read:	PTE7	PTE6	PTE5	PTE4	PTE3	PTE2	PTE1	PTE0
Write:	PTE7	PTE6	PTE5	PTE4	PTE3	PTE2	PTE1	PTE0
Reset:	Unaffected by reset							
Alternate Function:	SPSCK	MOSI	MISO	\overline{SS}	TACH1	TACH0	RxD	TxD

Figure 20-14. Port E Data Register (PTE)

PTE[7:0] — Port E Data Bits

PTE[7:0] are read/write, software programmable bits. Data direction of each port E pin is under the control of the corresponding bit in data direction register E.

SPSCK — SPI Serial Clock Bit

The PTE7/SPSCK pin is the serial clock input of an SPI slave module and serial clock output of an SPI master module. When the SPE bit is clear, the PTE7/SPSCK pin is available for general-purpose I/O.

MOSI — Master Out/Slave In Bit

The PTE6/MOSI pin is the master out/slave in terminal of the SPI module. When the SPE bit is clear, the PTE6/MOSI pin is available for general-purpose I/O. (See [18.14.1 SPI Control Register](#).)

MISO — Master In/Slave Out Bit

The PTE5/MISO pin is the master in/slave out terminal of the SPI module. When the SPI enable bit, SPE, is clear, the SPI module is disabled, and the PTE5/MISO pin is available for general-purpose I/O. (See [18.14.1 SPI Control Register](#).)

 \overline{SS} — Slave Select Bit

The PTE4/ \overline{SS} pin is the slave select input of the SPI module. When the SPE bit is clear, or when the SPI master bit, SPMSTR, is set and MODFEN bit is low, the PTE4/ \overline{SS} pin is available for general-purpose I/O. (See [18.13.4 SS \(Slave Select\)](#).) When the SPI is enabled as a slave, the DDRF4 bit in data direction register E (DDRE) has no effect on the PTE4/ \overline{SS} pin.

NOTE: *Data direction register E (DDRE) does not affect the data direction of port E pins that are being used by the SPI module. However, the DDRE bits always determine whether reading port E returns the states of the latches or the states of the pins. (See [Table 20-5](#).)*

TACH[1:0] — Timer Channel I/O Bits

The PTE3/TACH1–PTE2/TACH0 pins are the TIMA input capture/output compare pins. The edge/level select bits, ELSxB–ELSxA, determine whether the PTE3/TACH1–PTE2/TACH0 pins are timer channel I/O pins or general-purpose I/O pins. (See [22.9.4 TIMA Channel Status and Control Registers](#).)

NOTE: *Data direction register E (DDRE) does not affect the data direction of port E pins that are being used by the TIMA. However, the DDRE bits always determine whether reading port E returns the states of the latches or the states of the pins. (See [Table 20-5](#).)*

RxD — SCI Receive Data Input Bit

The PTE1/RxD pin is the receive data input for the SCI module. When the enable SCI bit, ENSCI, is clear, the SCI module is disabled, and the PTE1/RxD pin is available for general-purpose I/O. (See [17.9.1 SCI Control Register 1](#).)

TxD — SCI Transmit Data Output

The PTE0/TxD pin is the transmit data output for the SCI module. When the enable SCI bit, ENSCI, is clear, the SCI module is disabled, and the PTE0/TxD pin is available for general-purpose I/O. (See [17.9.1 SCI Control Register 1](#).)

NOTE: Data direction register E (DDRE) does not affect the data direction of port E pins that are being used by the SCI module. However, the DDRE bits always determine whether reading port E returns the states of the latches or the states of the pins. (See [Table 20-5](#).)

20.7.2 Data Direction Register E

Data direction register E (DDRE) determines whether each port E pin is an input or an output. Writing a logic 1 to a DDRE bit enables the output buffer for the corresponding port E pin; a logic 0 disables the output buffer.

Address: \$000C

	Bit 7	6	5	4	3	2	1	Bit 0
Read:	DDRE7	DDRE6	DDRE5	DDRE4	DDRE3	DDRE2	DDRE1	DDRE0
Write:								
Reset:	0	0	0	0	0	0	0	0

Figure 20-15. Data Direction Register E (DDRE)

DDRE[7:0] — Data Direction Register E Bits

These read/write bits control port E data direction. Reset clears DDRE[7:0], configuring all port E pins as inputs.

- 1 = Corresponding port E pin configured as output
- 0 = Corresponding port E pin configured as input

NOTE: Avoid glitches on port E pins by writing to the port E data register before changing data direction register E bits from 0 to 1.

[Figure 20-16](#) shows the port E I/O logic.

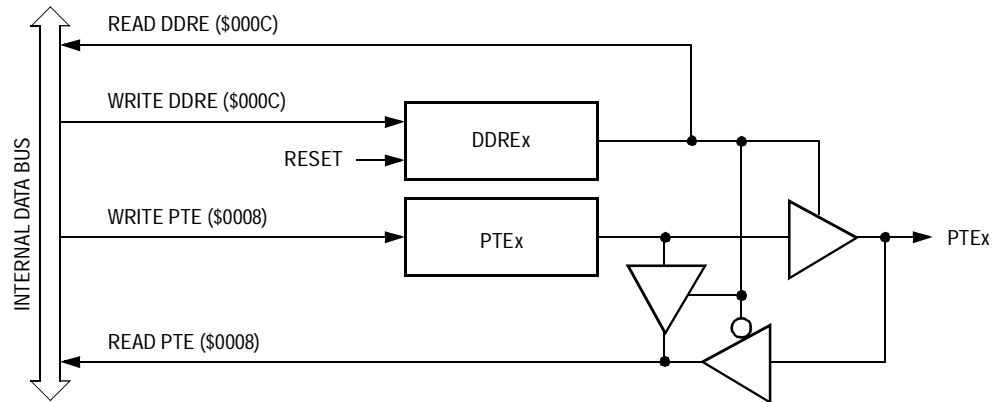

Figure 20-16. Port E I/O Circuit

When bit DDREx is a logic 1, reading address \$0008 reads the PTEx data latch. When bit DDREx is a logic 0, reading address \$0008 reads the voltage level on the pin. The data latch can always be written, regardless of the state of its data direction bit. Table 20-5 summarizes the operation of the port E pins.

Table 20-5. Port E Pin Functions

DDRE Bit	PTE Bit	I/O Pin Mode	Accesses to DDRE	Accesses to PTE	
			Read/Write	Read	Write
0	X	Input, Hi-Z	DDRE[7:0]	Pin	PTE[7:0] ⁽¹⁾
1	X	Output	DDRE[7:0]	PTE[7:0]	PTE[7:0]

X = Don't care

Hi-Z = High impedance

1. Writing affects data register, but does not affect input.

20.8 Port F

Port F is a 7-bit special function port that shares four of its pins with the timer interface module (TIMA).

NOTE: *The pins associated with PTF6, PTF5, and PTF4 are available only in the 64-pin QFP.*

20.8.1 Port F Data Register

The port F data register (PTF) contains a data latch for each of the six port F pins.

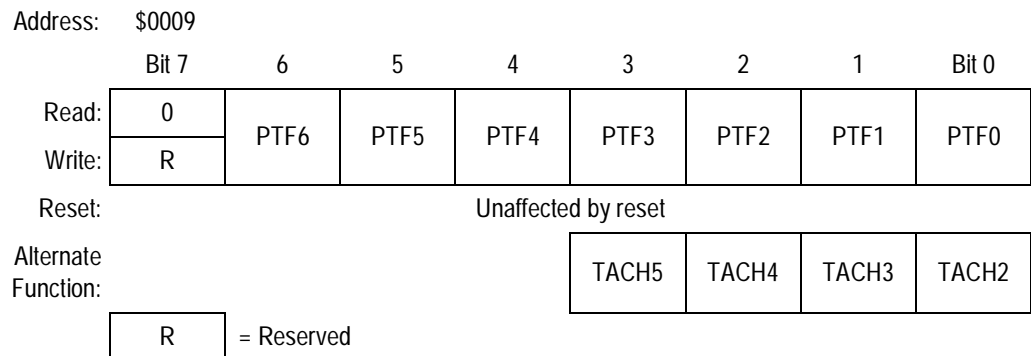

Figure 20-17. Port F Data Register (PTF)

PTF[6:0] — Port F Data Bits

These read/write bits are software programmable. Data direction of each port F pin is under the control of the corresponding bit in data direction register F. Reset has no effect on PTF[6:0].

TACH[5:2] — Timer Channel I/O Bits

The PTF3–PTF0/TACH2 pins are the TIMA input capture/output compare pins. The edge/level select bits, ELSxB–ELSxA, determine whether the PTF3–PTF0/TACH2 pins are timer channel I/O pins or general-purpose I/O pins. See [22.9.4 TIMA Channel Status and Control Registers](#).

NOTE: *Data direction register F (DDRF) does not affect the data direction of port F pins that are being used by the TIMA. However, the DDRF bits always determine whether reading port F returns the states of the latches or the states of the pins. (See [Table 20-6](#).)*

20.8.2 Data Direction Register F

Data direction register F (DDRF) determines whether each port F pin is an input or an output. Writing a logic 1 to a DDRF bit enables the output buffer for the corresponding port F pin; a logic 0 disables the output buffer.

Address: \$000D

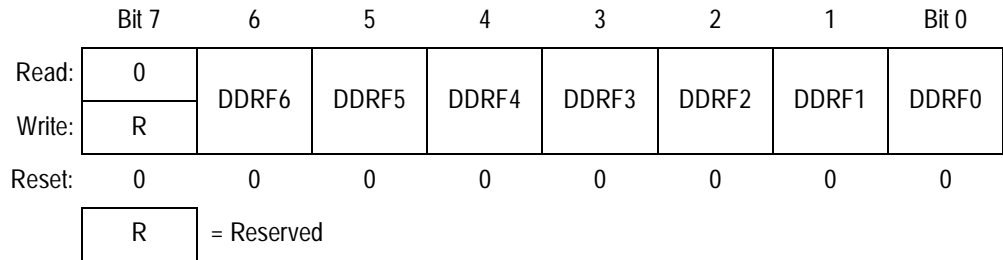

Figure 20-18. Data Direction Register F (DDRF)

DDRF[6:0] — Data Direction Register F Bits

These read/write bits control port F data direction. Reset clears DDRF[6:0], configuring all port F pins as inputs.

- 1 = Corresponding port F pin configured as output
- 0 = Corresponding port F pin configured as input

NOTE: Avoid glitches on port F pins by writing to the port F data register before changing data direction register F bits from 0 to 1.

Figure 20-19 shows the port F I/O logic.

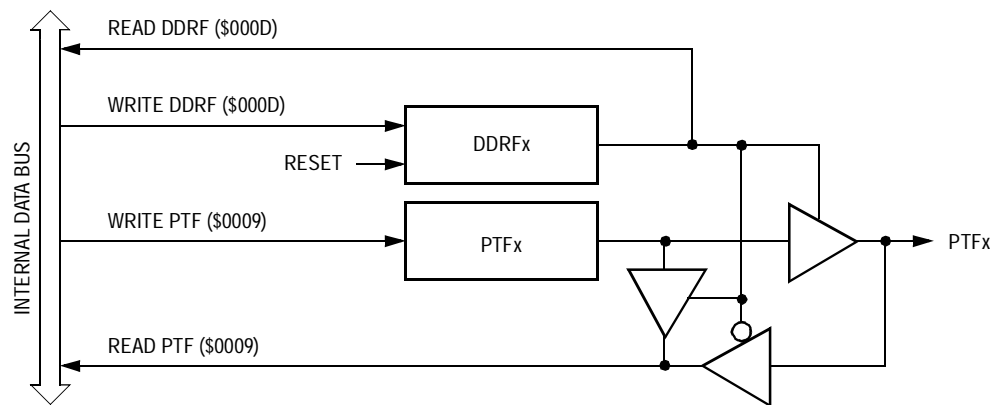

Figure 20-19. Port F I/O Circuit

When bit DDRFx is a logic 1, reading address \$0009 reads the PTFx data latch. When bit DDRFx is a logic 0, reading address \$0009 reads the voltage level on the pin. The data latch can always be written, regardless of the state of its data direction bit. [Table 20-6](#) summarizes the operation of the port F pins.

Table 20-6. Port F Pin Functions

DDRF Bit	PTF Bit	I/O Pin Mode	Accesses to DDRF	Accesses to PTF	
			Read/Write	Read	Write
0	X	Input, Hi-Z	DDRF[6:0]	Pin	PTF[6:0] ⁽¹⁾
1	X	Output	DDRF[6:0]	PTF[6:0]	PTF[6:0]

X = Don't care

Hi-Z = High impedance

1. Writing affects data register, but does not affect input.

20.9 Port G

Port G is a 3-bit, general-purpose, bidirectional I/O port.

NOTE: The pins of port G are available only in the 64-pin QFP.

20.9.1 Port G Data Register

The port G data register (PTG) contains a data latch for each of the three port G pins.

Address: \$000A

	Bit 7	6	5	4	3	2	1	Bit 0
Read:	0	0	0	0	0	PTG2	PTG1	PTG0
Write:	R	R	R	R	R			

Reset: Unaffected by reset

R = Reserved

Figure 20-20. Port G Data Register (PTG)

PTG[2:0] — Port G Data Bits

These read/write bits are software programmable. Data direction of each port G pin is under the control of the corresponding bit in data direction register G. Reset has no effect on PTG[2:0].

20.9.2 Data Direction Register G

Data direction register G (DDRG) determines whether each port G pin is an input or an output. Writing a logic 1 to a DDRG bit enables the output buffer for the corresponding port G pin; a logic 0 disables the output buffer.

Address: \$000E

	Bit 7	6	5	4	3	2	1	Bit 0
Read:	0	0	0	0	0	DDRG2	DDRG1	DDRG0
Write:	R	R	R	R	R			
Reset:	0	0	0	0	0	0	0	0

R = Reserved

Figure 20-21. Data Direction Register G (DDRG)

DDRG[2:0] — Data Direction Register G Bits

These read/write bits control port G data direction. Reset clears DDRG[2:0], configuring all port G pins as inputs.

- 1 = Corresponding port G pin configured as output
- 0 = Corresponding port G pin configured as input

NOTE: Avoid glitches on port G pins by writing to the port G data register before changing data direction register G bits from 0 to 1.

Figure 20-22 shows the port G I/O logic.

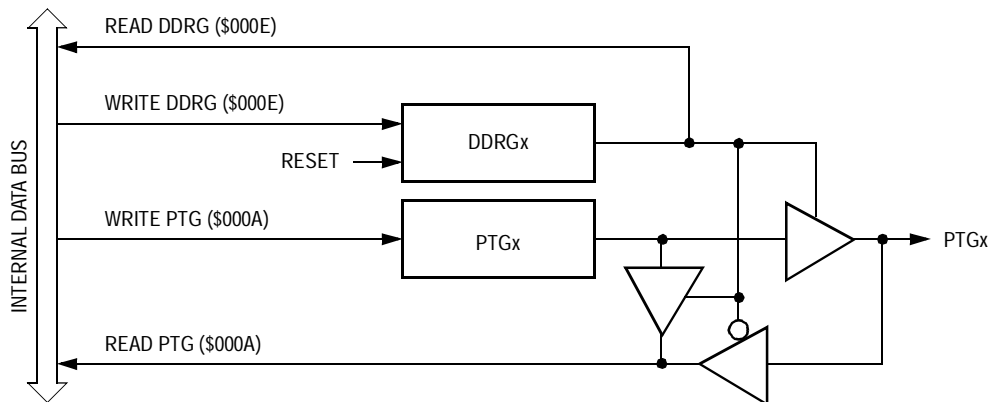

Figure 20-22. Port G I/O Circuit

When bit DDRGx is a logic 1, reading address \$000A reads the PTGx data latch. When bit DDRGx is a logic 0, reading address \$000A reads the voltage level on the pin. The data latch can always be written, regardless of the state of its data direction bit. Table 20-7 summarizes the operation of the port G pins.

Table 20-7. Port G Pin Functions

DDRG Bit	PTG Bit	I/O Pin Mode	Accesses to DDRG	Accesses to PTG	
			Read/Write	Read	Write
0	X	Input, Hi-Z	DDRG[2:0]	Pin	PTG[2:0] ⁽¹⁾
1	X	Output	DDRG[2:0]	PTG[2:0]	PTG[2:0]

X = Don't care

Hi-Z = High impedance

1. Writing affects data register, but does not affect input.

20.10 Port H

Port H is a 2-bit, general-purpose, bidirectional I/O port.

NOTE: The pins of port H are available only in the 64-pin QFP.

20.10.1 Port H Data Register

The port H data register (PTH) contains a data latch for each of the two port H pins.

Address: \$000B

	Bit 7	6	5	4	3	2	1	Bit 0
Read:	0	0	0	0	0	0	PTH1	PTH0
Write:	R	R	R	R	R	R		

Reset: Unaffected by reset

R

 = Reserved

Figure 20-23. Port H Data Register (PTH)

PTH[1:0] — Port H Data Bits

These read/write bits are software programmable. Data direction of each port H pin is under the control of the corresponding bit in data direction register H. Reset has no effect on PTH[1:0].

20.10.2 Data Direction Register H

Data direction register H (DDRH) determines whether each port H pin is an input or an output. Writing a logic 1 to a DDRH bit enables the output buffer for the corresponding port H pin; a logic 0 disables the output buffer.

Address: \$000F

	Bit 7	6	5	4	3	2	1	Bit 0
Read:	0	0	0	0	0	0	DDRH1	DDRH0
Write:	R	R	R	R	R	R		
Reset:	0	0	0	0	0	0	0	0

R = Reserved

Figure 20-24. Data Direction Register H (DDRH)

DDRH[1:0] — Data Direction Register H Bits

These read/write bits control port H data direction. Reset clears DDRG[1:0], configuring all port H pins as inputs.

- 1 = Corresponding port H pin configured as output
- 0 = Corresponding port H pin configured as input

NOTE: Avoid glitches on port H pins by writing to the port H data register before changing data direction register H bits from 0 to 1.

Figure 20-25 shows the port H I/O logic.

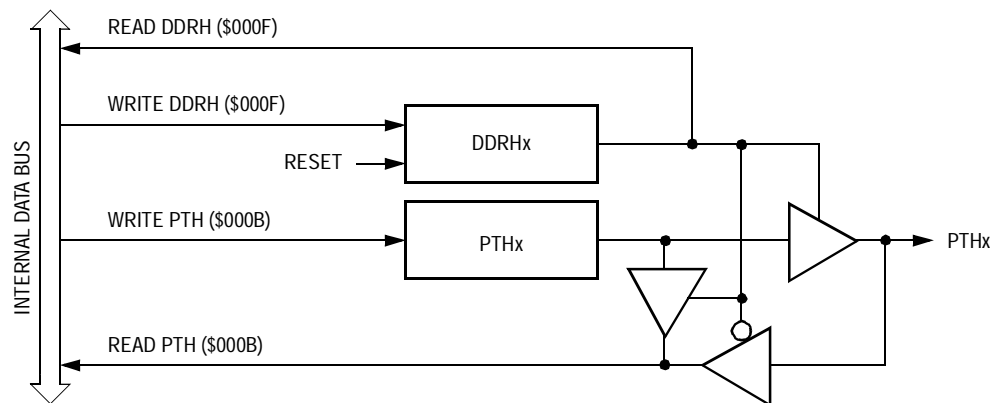

Figure 20-25. Port H I/O Circuit

When bit DDRHx is a logic 1, reading address \$000B reads the PTHx data latch. When bit DDRHx is a logic 0, reading address \$000B reads the voltage level on the pin. The data latch can always be written, regardless of the state of its data direction bit. **Table 20-8** summarizes the operation of the port H pins.

Table 20-8. Port H Pin Functions

DDRH Bit	PTH Bit	I/O Pin Mode	Accesses to DDRH	Accesses to PTH	
			Read/Write	Read	Write
0	X	Input, Hi-Z	DDRH[1:0]	Pin	PTH[1:0] ⁽¹⁾
1	X	Output	DDRH[1:0]	PTH[1:0]	PTH[1:0]

X = don't care

Hi-Z = high impedance

1. Writing affects data register, but does not affect input.

Section 21. Byte Data Link Controller-Digital (BDLC-D)

21.1 Contents

21.2	Introduction	329
21.3	Features	329
21.4	Functional Description	330
21.4.1	BDLC Operating Modes	331
21.4.1.1	Power Off Mode	331
21.4.1.2	Reset Mode	332
21.4.1.3	Run Mode	333
21.4.1.4	Wait Mode	333
21.4.1.5	Stop Mode	333
21.4.1.6	Digital Loopback Mode	334
21.4.1.7	Analog Loopback Mode	334
21.5	BDLC MUX Interface	335
21.5.1	Rx Digital Filter	335
21.5.1.1	Operation	336
21.5.1.2	Performance	336
21.5.2	J1850 Frame Format	337
21.5.2.1	Start-of-Frame Symbol (SOF)	337
21.5.2.2	In-Message Data Bytes (Data)	338
21.5.2.3	Cyclical Redundancy Check Byte (CRC)	338
21.5.2.4	End-of-Data Symbol (EOD)	339
21.5.2.5	In-Frame Response Bytes (IFR)	339
21.5.2.6	End-of-Frame Symbol (EOF)	340
21.5.2.7	Inter-Frame Separation Symbol (IFS)	340
21.5.2.8	Break (BREAK)	341
21.5.2.9	Idle Bus (IDLE)	341
21.5.3	J1850 VPW Symbols	341
21.5.3.1	Logic 0	342
21.5.3.2	Logic 1	342
21.5.3.3	Normalization Bit (NB)	344
21.5.3.4	Break Signal (BREAK)	344

21.5.3.5	Start-of-Frame Symbol (SOF)	344
21.5.3.6	End-of-Data Symbol (EOD)	344
21.5.3.7	End-of-Frame Symbol (EOF)	344
21.5.3.8	Inter-Frame Separation Symbol (IFS)	344
21.5.3.9	Idle	344
21.5.4	J1850 VPW Valid/Invalid Bits and Symbols	345
21.5.4.1	Invalid Passive Bit	345
21.5.4.2	Valid Passive Logic 0	345
21.5.4.3	Valid Passive Logic 1	346
21.5.4.4	Valid EOD Symbol	346
21.5.4.5	Valid EOF and IFS Symbols	346
21.5.4.6	Idle Bus	347
21.5.4.7	Invalid Active Bit	348
21.5.4.8	Valid Active Logic 1	348
21.5.4.9	Valid Active Logic 0	348
21.5.4.10	Valid SOF Symbol	349
21.5.4.11	Valid BREAK Symbol	349
21.5.5	Message Arbitration	349
21.6	BDLC Protocol Handler	351
21.6.1	Protocol Architecture	352
21.6.2	Rx and Tx Shift Registers	352
21.6.3	Rx and Tx Shadow Registers	353
21.6.4	Digital Loopback Multiplexer	353
21.6.5	State Machine	353
21.6.5.1	4X Mode	353
21.6.5.2	Receiving a Message in Block Mode	354
21.6.5.3	Transmitting a Message in Block Mode	354
21.6.5.4	J1850 Bus Errors	354
21.6.5.5	Summary	356
21.7	BDLC CPU Interface	357
21.7.1	BDLC Analog and Roundtrip Delay	358
21.7.2	BDLC Control Register 1	359
21.7.3	BDLC Control Register 2	362
21.7.4	BDLC State Vector Register	370
21.7.5	BDLC Data Register	372
21.8	Low-Power Modes	373
21.8.1	Wait Mode	373
21.8.2	Stop Mode	373

21.2 Introduction

The byte data link controller (BDLC) provides access to an external serial communication multiplex bus, operating according to the SAE J1850 protocol.

21.3 Features

Features of the BDLC module include:

- *SAE J1850 Class B Data Communications Network Interface* compatible and ISO compatible for low-speed (≤ 125 kbps) serial data communications in automotive applications
- 10.4 kbps variable pulse width (VPW) bit format
- Digital noise filter
- Collision detection
- Hardware cyclical redundancy check (CRC) generation and checking
- Two power-saving modes with automatic wakeup on network activity
- Polling or CPU interrupts
- Block mode receive and transmit supported
- 4X receive mode, 41.6 kbps, supported
- Digital loopback mode
- Analog loopback mode
- In-frame response (IFR) types 0, 1, 2, and 3 supported

21.4 Functional Description

Figure 21-1 shows the organization of the BDLC module. The CPU interface contains the software addressable registers and provides the link between the CPU and the buffers. The buffers provide storage for data received and data to be transmitted onto the J1850 bus. The protocol handler is responsible for the encoding and decoding of data bits and special message symbols during transmission and reception. The multiplex (MUX) interface provides the link between the BDLC digital section and the analog physical interface. The wave shaping, driving, and digitizing of data is performed by the physical interface.

Use of the BDLC module in message networking fully implements the *SAE Standard J1850 Class B Data Communication Network Interface* specification.

NOTE: *It is recommended that the reader be familiar with the SAE J1850 document and ISO Serial Communication document prior to proceeding with this section of the MC68HC908AS60 specification.*

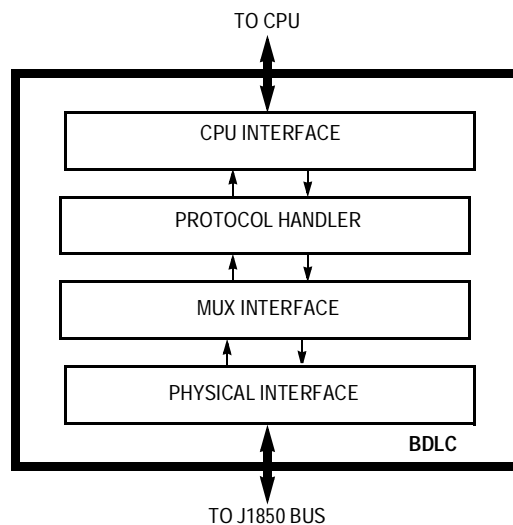

Figure 21-1. BDLC Block Diagram

Addr.	Register Name	Bit 7	6	5	4	3	2	1	Bit 0	
\$003B	BDLC Analog and Roundtrip Delay Register (BARD) See page 358.	Read:	ATE	RXPOL	0	0	BO3	BO2	BO1	BO0
		Write:								
		Reset:	1	1	0	0	0	1	1	1
\$003C	BDLC Control Register 1 (BCR1) See page 359.	Read:	IMSG	CLKS	R1	R0	0	0	IE	WCM
		Write:					R	R		
		Reset:	1	1	1	0	0	0	0	0
\$003D	BDLC Control Register 2 (BCR2) See page 362.	Read:	ALOOP	DLOOP	RX4XE	NBFS	TEOD	TSIFR	TMIFR1	TMIFR0
		Write:								
		Reset:	1	1	0	0	0	0	0	0
\$003E	BDLC State Vector Register (BSVR) See page 370.	Read:	0	0	I3	I2	I1	I0	0	0
		Write:								
		Reset:	0	0	0	0	0	0	0	0
\$003F	BDLC Data Register (BDR) See page 372.	Read:	BD7	BD6	BD5	BD4	BD3	BD2	BD1	BD0
		Write:								
		Reset:	Indeterminate after reset							

= Unimplemented
 R = Reserved

Figure 21-2. BDLC I/O Register Summary

21.4.1 BDLC Operating Modes

The BDLC has five main modes of operation which interact with the power supplies, pins, and rest of the MCU as shown in [Figure 21-3](#).

21.4.1.1 Power Off Mode

For the BDLC to guarantee operation, this mode is entered from reset mode whenever the BDLC supply voltage, V_{DD} , drops below its minimum specified value. The BDLC will be placed in reset mode by low-voltage reset (LVR) before being powered down. In power off mode, the pin input and output specifications are not guaranteed.

Byte Data Link Controller-Digital (BDLC-D)

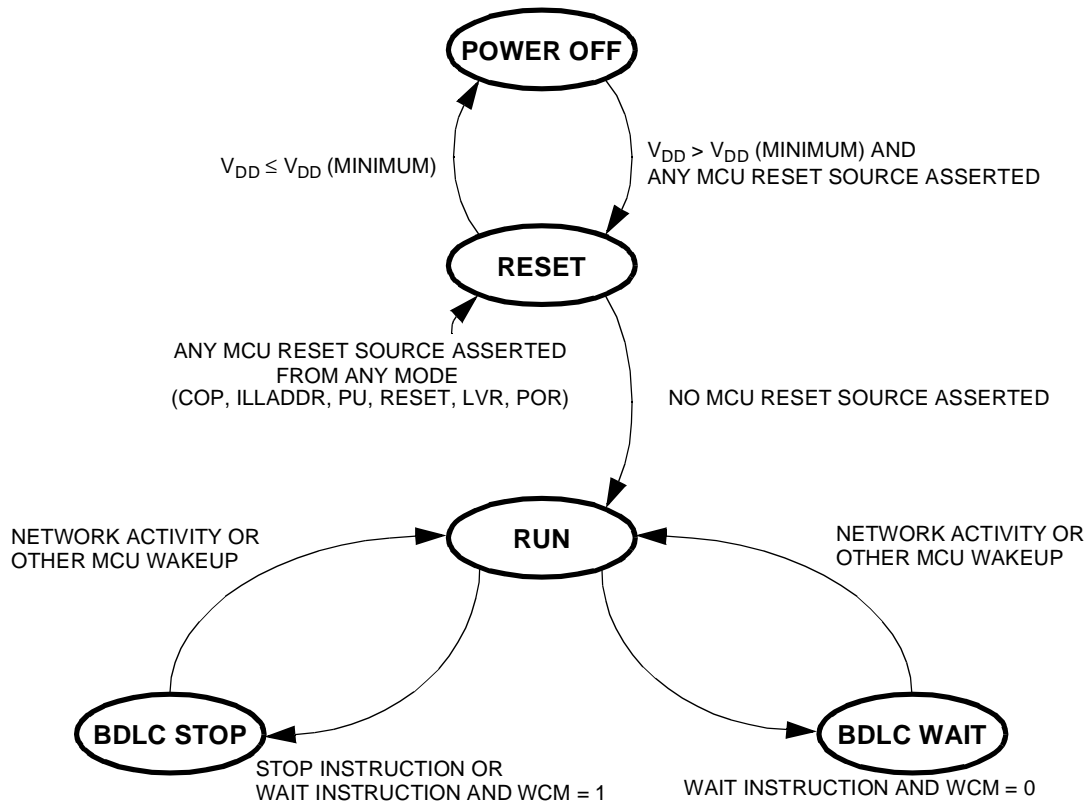

Figure 21-3. BDLC Operating Modes State Diagram

21.4.1.2 Reset Mode

This mode is entered from power off mode whenever the BDLC supply voltage, V_{DD} , rises above its minimum specified value ($V_{DD} - 10\%$) and some MCU reset source is asserted. The internal MCU reset must be asserted while powering up the BDLC or an unknown state will be entered and correct operation cannot be guaranteed. Reset mode is also entered from any other mode as soon as one of the MCU's possible reset sources (such as LVR, POR, COP watchdog, reset pin, etc.) is asserted.

In reset mode, the internal BDLC voltage references are operative, V_{DD} is supplied to the internal circuits which are held in their reset state, and the internal BDLC system clock is running. Registers will assume their reset condition. Because outputs are held in their programmed reset state, inputs and network activity are ignored.

21.4.1.3 Run Mode

This mode is entered from reset mode after all MCU reset sources are no longer asserted. Run mode is entered from the BDLC wait mode whenever activity is sensed on the J1850 bus.

Run mode is entered from the BDLC stop mode whenever network activity is sensed, although messages will not be received properly until the clocks have stabilized and the CPU is also in run mode.

In this mode, normal network operation takes place. The user should ensure that all BDLC transmissions have ceased before exiting this mode.

21.4.1.4 Wait Mode

This power-conserving mode is entered automatically from run mode whenever the CPU executes a WAIT instruction and if the WCM bit in the BCR1 register is cleared previously.

In this mode, the BDLC internal clocks continue to run. The first passive-to-active transition of the bus generates a CPU interrupt request from the BDLC, which wakes up the BDLC and the CPU. In addition, if the BDLC receives a valid end-of-frame (EOF) symbol while operating in wait mode, then the BDLC also will generate a CPU interrupt request, which wakes up the BDLC and the CPU. See [21.8.1 Wait Mode](#).

21.4.1.5 Stop Mode

This power-conserving mode is entered automatically from run mode whenever the CPU executes a STOP instruction or if the CPU executes a WAIT instruction and the WCM bit in the BCR1 is set previously.

In this mode, the BDLC internal clocks are stopped but the physical interface circuitry is placed in a low-power mode and awaits network activity. If network activity is sensed, then a CPU interrupt request will be generated, restarting the BDLC internal clocks. See [21.8.2 Stop Mode](#).

21.4.1.6 *Digital Loopback Mode*

When a bus fault has been detected, the digital loopback mode is used to determine if the fault condition is caused by failure in the node's internal circuits or elsewhere in the network, including the node's analog physical interface. In this mode, the transmit digital output pin (BDTxD) and the receive digital input pin (BDRxD) of the digital interface are disconnected from the analog physical interface and tied together to allow the digital portion of the BDLC to transmit and receive its own messages without driving the J1850 bus.

21.4.1.7 *Analog Loopback Mode*

Analog loopback mode is used to determine if a bus fault has been caused by a failure in the node's off-chip analog transceiver or elsewhere in the network. The BDLC analog loopback mode does not modify the digital transmit or receive functions of the BDLC. It does, however, ensure that once analog loopback mode is exited, the BDLC will wait for an idle bus condition before participation in network communication resumes. If the off-chip analog transceiver has a loopback mode, it usually causes the input to the output drive stage to be looped back into the receiver, allowing the node to receive messages it has transmitted without driving the J1850 bus. In this mode, the output to the J1850 bus typically is high impedance. This allows the communication path through the analog transceiver to be tested without interfering with network activity. Using the BDLC analog loopback mode in conjunction with the analog transceiver's loopback mode ensures that, once the off-chip analog transceiver has exited loopback mode, the BCLD will not begin communicating before a known condition exists on the J1850 bus.

21.5 BDLC MUX Interface

The MUX interface is responsible for bit encoding/decoding and digital noise filtering between the protocol handler and the physical interface.

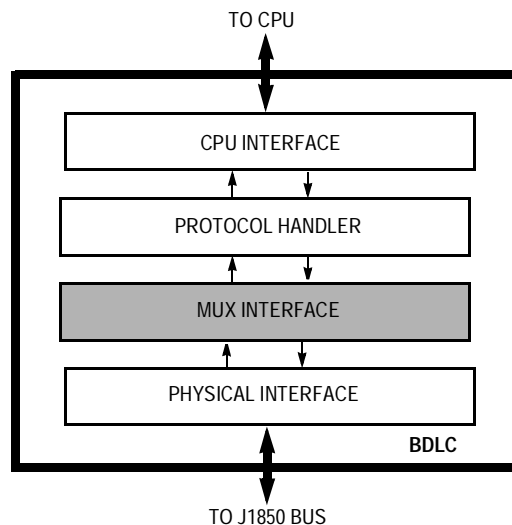

Figure 21-4. BDLC Block Diagram

21.5.1 Rx Digital Filter

The receiver section of the BDLC includes a digital low-pass filter to remove narrow noise pulses from the incoming message. An outline of the digital filter is shown in [Figure 21-5](#).

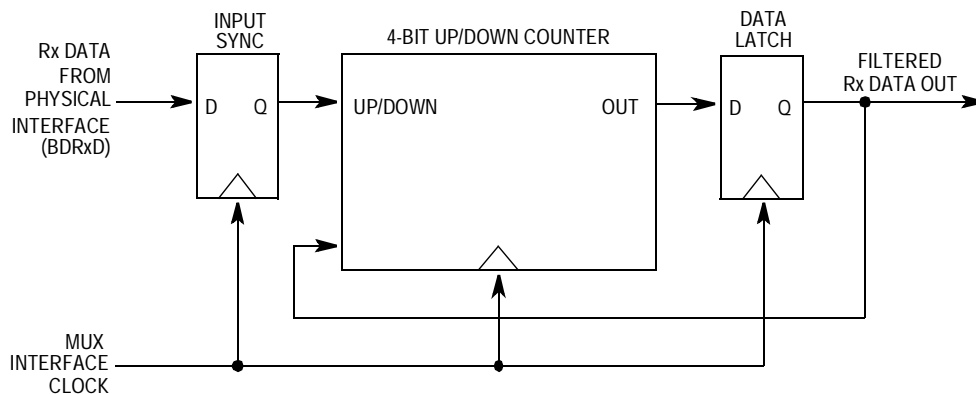

Figure 21-5. BDLC Rx Digital Filter Block Diagram

21.5.1.1 Operation

The clock for the digital filter is provided by the MUX interface clock (see f_{BDLC} parameter in [Table 21-3](#)). At each positive edge of the clock signal, the current state of the receiver physical interface (BDRxD) signal is sampled. The BDRxD signal state is used to determine whether the counter should increment or decrement at the next negative edge of the clock signal.

The counter will increment if the input data sample is high but decrement if the input sample is low. Therefore, the counter will thus progress either up toward 15 if, on average, the BDRxD signal remains high or progress down toward 0 if, on average, the BDRxD signal remains low.

When the counter eventually reaches the value 15, the digital filter decides that the condition of the BDRxD signal is at a stable logic level 1 and the data latch is set, causing the filtered Rx data signal to become a logic level 1. Furthermore, the counter is prevented from overflowing and can be decremented only from this state.

Alternatively, should the counter eventually reach the value 0, the digital filter decides that the condition of the BDRxD signal is at a stable logic level 0 and the data latch is reset, causing the filtered Rx data signal to become a logic level 0. Furthermore, the counter is prevented from underflowing and can only be incremented from this state.

The data latch will retain its value until the counter next reaches the opposite end point, signifying a definite transition of the signal.

21.5.1.2 Performance

The performance of the digital filter is best described in the time domain rather than the frequency domain.

If the signal on the BDRxD signal transitions, then there will be a delay before that transition appears at the filtered Rx data output signal. This delay will be between 15 and 16 clock periods, depending on where the transition occurs with respect to the sampling points. This filter delay must be taken into account when performing message arbitration.

For example, if the frequency of the MUX interface clock (f_{BDLC}) is 1.0486 MHz, then the period (t_{BDLC}) is 954 ns and the maximum filter delay in the absence of noise will be 15.259 μs .

The effect of random noise on the BDRxD signal depends on the characteristics of the noise itself. Narrow noise pulses on the BDRxD signal will be ignored completely if they are shorter than the filter delay. This provides a degree of low pass filtering.

If noise occurs during a symbol transition, the detection of that transition can be delayed by an amount equal to the length of the noise burst. This is just a reflection of the uncertainty of where the transition is truly occurring within the noise.

Noise pulses that are wider than the filter delay, but narrower than the shortest allowable symbol length, will be detected by the next stage of the BDLC's receiver as an invalid symbol.

Noise pulses that are longer than the shortest allowable symbol length will be detected normally as an invalid symbol or as invalid data when the frame's CRC is checked.

21.5.2 J1850 Frame Format

All messages transmitted on the J1850 bus are structured using the format shown in [Figure 21-6](#).

J1850 states that each message has a maximum length of 101 PWM bit times or 12 VPW bytes, excluding SOF, EOD, NB, and EOF, with each byte transmitted most significant bit (MSB) first.

All VPW symbol lengths described here are typical values at a 10.4-kbps bit rate.

21.5.2.1 Start-of-Frame Symbol (SOF)

All messages transmitted onto the J1850 bus must begin with a long-active 200- μs period SOF symbol. This indicates the start of a new message transmission. The SOF symbol is not used in the CRC calculation.

Byte Data Link Controller-Digital (BDLC-D)

21.5.2.2 In-Message Data Bytes (Data)

The data bytes contained in the message include the message priority/type, message ID byte (typically the physical address of the responder), and any actual data being transmitted to the receiving node. The message format used by the BDLC is similar to the 3-byte consolidated header message format outlined by the SAE J1850 document. See *SAE J1850 Class B Data Communications Network Interface* for more information about 1- and 3-byte headers.

Messages transmitted by the BDLC onto the J1850 bus must contain at least one data byte, and, therefore, can be as short as one data byte and one CRC byte. Each data byte in the message is eight bits in length and is transmitted MSB to LSB (least significant bit).

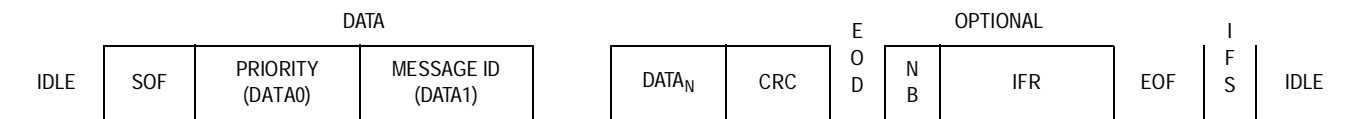

Figure 21-6. J1850 Bus Message Format (VPW)

21.5.2.3 Cyclical Redundancy Check Byte (CRC)

This byte is used by the receiver(s) of each message to determine if any errors have occurred during the transmission of the message. The BDLC calculates the CRC byte and appends it onto any messages transmitted onto the J1850 bus. It also performs CRC detection on any messages it receives from the J1850 bus.

CRC generation uses the divisor polynomial $X^8 + X^4 + X^3 + X^2 + 1$. The remainder polynomial initially is set to all 1s. Each byte in the message after the start-of-frame (SOF) symbol is processed serially through the CRC generation circuitry. The one's complement of the remainder then becomes the 8-bit CRC byte, which is appended to the message after the data bytes, in MSB-to-LSB order.

When receiving a message, the BDLC uses the same divisor polynomial. All data bytes, excluding the SOF and end of data symbols (EOD) but including the CRC byte, are used to check the CRC. If the message is error free, the remainder polynomial will equal

$X^7 + X^6 + X^2 = \$C4$, regardless of the data contained in the message. If the calculated CRC does not equal $\$C4$, the BDLC will recognize this as a CRC error and set the CRC error flag in the BSVR.

21.5.2.4 End-of-Data Symbol (EOD)

The EOD symbol is a long 200- μ s passive period on the J1850 bus used to signify to any recipients of a message that the transmission by the originator has completed. No flag is set upon reception of the EOD symbol.

21.5.2.5 In-Frame Response Bytes (IFR)

The IFR section of the J1850 message format is optional. Users desiring further definition of in-frame response should review the *SAE J1850 Class B Data Communications Network Interface* specification.

WARNING: *When the BDLC is programmed to transmit a single byte Type 2 IFR (byte loaded in the BDR and TSIFR bit set in BCR2), the BDLC will attempt to transmit a single IFR byte following the EOD of the message currently being received. If the byte to be transmitted loses arbitration, the BDLC will continue to retry transmission until it is successful or an error occurs or the TEOD bit is set. When the BDLC does win arbitration and transmits its single byte IFR, it does not receive additional IFR bytes transmitted from other nodes properly, instead generates an invalid symbol interrupt.*

NOTE: *The user can compensate for the condition described in the previous paragraph by following this procedure:*

- *When the first RXIFR interrupt occurs, the requester message has been received without errors (invalid symbol or CRC).*
- *When the BDLC receives back correctly the IFR byte it was trying to transmit, then response by this node is complete. The requester message received can be passed to the application layer.*
- *Ignore any invalid symbol error that occurs after the first RXIFR interrupt, since transmission of IFRs are not retried.*

21.5.2.6 End-of-Frame Symbol (EOF)

This symbol is a long 280- μ s passive period on the J1850 bus and is longer than an end-of-data (EOD) symbol, which signifies the end of a message. Since an EOF symbol is longer than a 200- μ s EOD symbol, if no response is transmitted after an EOD symbol, it becomes an EOF, and the message is assumed to be completed. The EOF flag is set upon receiving the EOF symbol.

21.5.2.7 Inter-Frame Separation Symbol (IFS)

The IFS symbol is a 20- μ s passive period on the J1850 bus which allows proper synchronization between nodes during continuous message transmission. The IFS symbol is transmitted by a node after the completion of the end-of-frame (EOF) period and, therefore, is seen as a 300- μ s passive period.

When the last byte of a message has been transmitted onto the J1850 bus and the EOF symbol time has expired, all nodes then must wait for the IFS symbol time to expire before transmitting a start-of-frame (SOF) symbol, marking the beginning of another message.

However, if the BDLC is waiting for the IFS period to expire before beginning a transmission and a rising edge is detected before the IFS time has expired, it will synchronize internally to that edge.

A rising edge may occur during the IFS period because of varying clock tolerances and loading of the J1850 bus, causing different nodes to observe the completion of the IFS period at different times. To allow for individual clock tolerances, receivers must synchronize to any SOF occurring during an IFS period.

21.5.2.8 Break (BREAK)

The BDLC cannot transmit a BREAK symbol.

If the BDLC is transmitting at the time a BREAK is detected, it treats the BREAK as if a transmission error had occurred and halts transmission.

If the BDLC detects a BREAK symbol while receiving a message, it treats the BREAK as a reception error and sets the invalid symbol flag in the BSVR, also ignoring the frame it was receiving. If while receiving a message in 4X mode, the BDLC detects a BREAK symbol, it treats the BREAK as a reception error, sets the invalid symbol flag, and exits 4X mode (for example, the RX4XE bit in BCR2 is cleared automatically). If bus control is required after the BREAK symbol is received and the IFS time has elapsed, the programmer must resend the transmission byte using highest priority.

NOTE: *The J1850 protocol BREAK symbol is not related to the M68HC08 break module (see [Section 12. Break Module](#)).*

21.5.2.9 Idle Bus (IDLE)

An idle condition exists on the bus during any passive period after expiration of the IFS period (for example, > 300 μ s). Any node sensing an idle bus condition can begin transmission immediately.

21.5.3 J1850 VPW Symbols

Huntsinger's variable pulse-width modulation (VPW) is an encoding technique in which each bit is defined by the time between successive transitions and by the level of the bus between transitions (for instance, active or passive). Active and passive bits are used alternately. This encoding technique is used to reduce the number of bus transitions for a given bit rate.

Each logic 1 or logic 0 contains a single transition and can be at either the active or passive level and one of two lengths, either 64 μ s or 128 μ s (t_{NOM} at 10.4 kbps baud rate), depending on the encoding of the previous bit. The start-of-frame (SOF), end-of-data (EOD), end-of-frame

(EOF), and inter-frame separation (IFS) symbols always will be encoded at an assigned level and length. See [Figure 21-7](#).

Each message will begin with an SOF symbol, an active symbol, and, therefore, each data byte (including the CRC byte) will begin with a passive bit, regardless of whether it is a logic 1 or a logic 0.

All VPW bit lengths stated in the following descriptions are typical values at a 10.4-kbps bit rate. EOF, EOD, IFS, and IDLE, however, are not driven J1850 bus states. They are passive bus periods observed by each node's CPU.

21.5.3.1 Logic 0

A logic 0 is defined as either:

- An active-to-passive transition followed by a passive period 64 μ s in length, or
- A passive-to-active transition followed by an active period 128 μ s in length

See [Figure 21-7 \(a\)](#).

21.5.3.2 Logic 1

A logic 1 is defined as either:

- An active-to-passive transition followed by a passive period 128 μ s in length, or
- A passive-to-active transition followed by an active period 64 μ s in length

See [Figure 21-7 \(b\)](#).

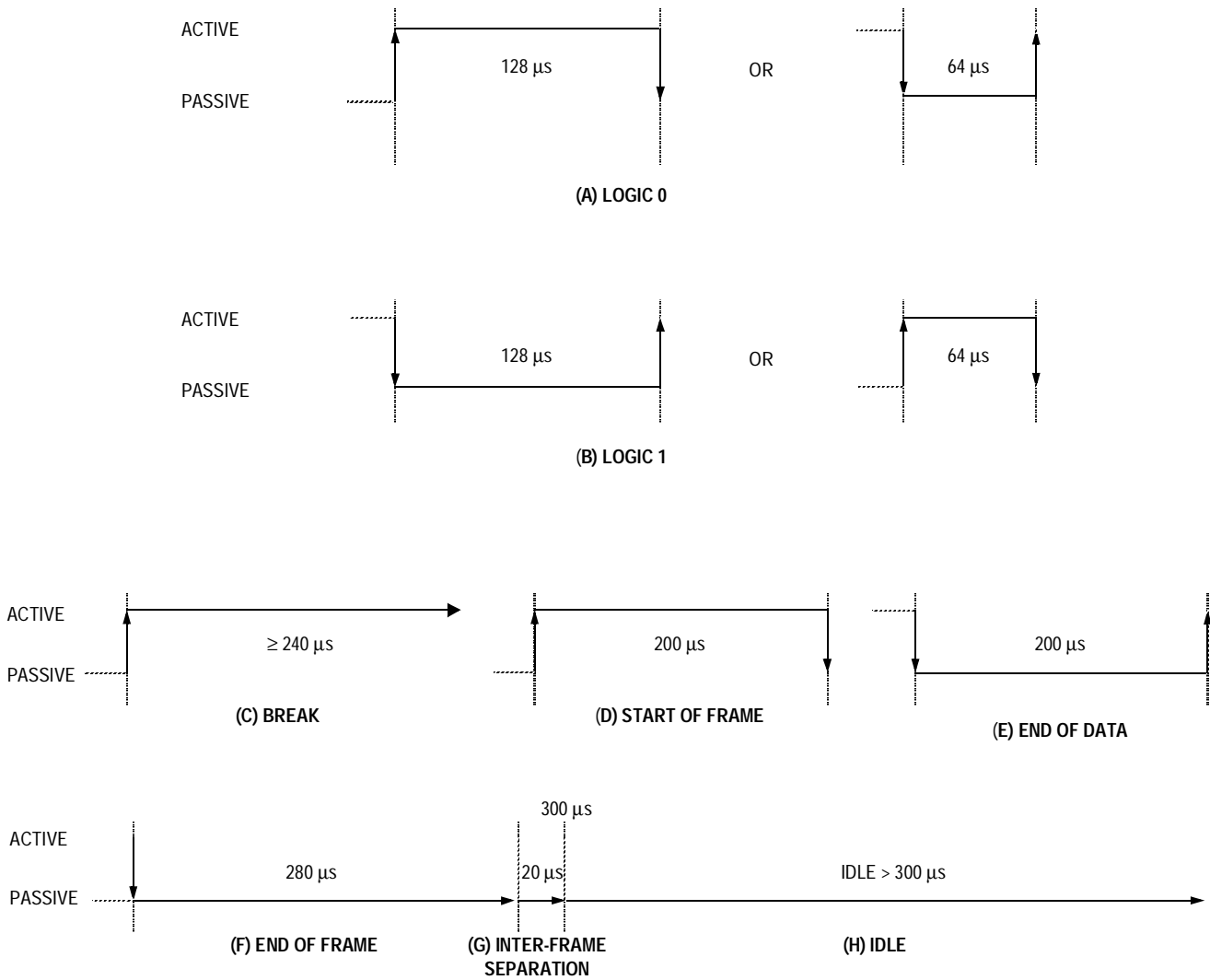

Figure 21-7. J1850 VPW Symbols with Nominal Symbol Times

Byte Data Link Controller-Digital (BDLC-D)

21.5.3.3 Normalization Bit (NB)

The NB symbol has the same property as a logic 1 or a logic 0. It is only used in IFR message responses.

21.5.3.4 Break Signal (BREAK)

The BREAK signal is defined as a passive-to-active transition followed by an active period of at least 240 μs (see [Figure 21-7 \(c\)](#)).

21.5.3.5 Start-of-Frame Symbol (SOF)

The SOF symbol is defined as passive-to-active transition followed by an active period 200 μs in length (see [Figure 21-7 \(d\)](#)). This allows the data bytes which follow the SOF symbol to begin with a passive bit, regardless of whether it is a logic 1 or a logic 0.

21.5.3.6 End-of-Data Symbol (EOD)

The EOD symbol is defined as an active-to-passive transition followed by a passive period 200 μs in length (see [Figure 21-7 \(e\)](#)).

21.5.3.7 End-of-Frame Symbol (EOF)

The EOF symbol is defined as an active-to-passive transition followed by a passive period 280 μs in length (see [Figure 21-7 \(f\)](#)). If no IFR byte is transmitted after an EOD symbol is transmitted, after another 80 μs the EOD becomes an EOF, indicating completion of the message.

21.5.3.8 Inter-Frame Separation Symbol (IFS)

The IFS symbol is defined as a passive period 300 μs in length. The 20- μs IFS symbol contains no transition, since when it is used it always appends to a 280- μs EOF symbol (see [Figure 21-7 \(g\)](#)).

21.5.3.9 Idle

An idle is defined as a passive period greater than 300 μs in length.

21.5.4 J1850 VPW Valid/Invalid Bits and Symbols

The timing tolerances for receiving data bits and symbols from the J1850 bus have been defined to allow for variations in oscillator frequencies. In many cases, the maximum time allowed to define a data bit or symbol is equal to the minimum time allowed to define another data bit or symbol.

Since the minimum resolution of the BDLC for determining what symbol is being received is equal to a single period of the MUX interface clock (t_{BDLC}), an apparent separation in these maximum time/minimum time concurrences equals one cycle of t_{BDLC} .

This one clock resolution allows the BDLC to differentiate properly between the different bits and symbols. This is done without reducing the valid window for receiving bits and symbols from transmitters onto the J1850 bus, which has varying oscillator frequencies.

In Huntsinger's variable pulse width (VPW) modulation bit encoding, the tolerances for both the passive and active data bits received and the symbols received are defined with no gaps between definitions. For example, the maximum length of a passive logic 0 is equal to the minimum length of a passive logic 1, and the maximum length of an active logic 0 is equal to the minimum length of a valid SOF symbol.

21.5.4.1 Invalid Passive Bit

See **Figure 21-8 (1)**. If the passive-to-active received transition beginning the next data bit or symbol occurs between the active-to-passive transition beginning the current data bit (or symbol) and **a**, the current bit would be invalid.

21.5.4.2 Valid Passive Logic 0

See **Figure 21-8 (2)**. If the passive-to-active received transition beginning the next data bit (or symbol) occurs between **a** and **b**, the current bit would be considered a logic 0.

Byte Data Link Controller-Digital (BDLC-D)

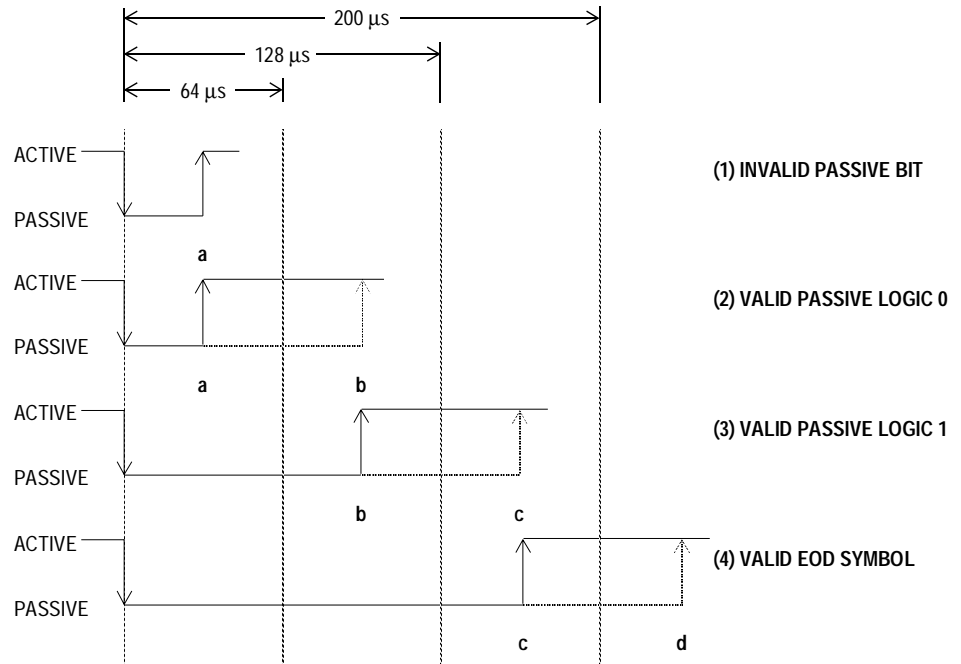

Figure 21-8. J1850 VPW Received Passive Symbol Times

21.5.4.3 Valid Passive Logic 1

See **Figure 21-8 (3)**. If the passive-to-active received transition beginning the next data bit (or symbol) occurs between **b** and **c**, the current bit would be considered a logic 1.

21.5.4.4 Valid EOD Symbol

See **Figure 21-8 (4)**. If the passive-to-active received transition beginning the next data bit (or symbol) occurs between **c** and **d**, the current symbol would be considered a valid end-of-data symbol (EOD).

21.5.4.5 Valid EOF and IFS Symbols

In **Figure 21-9 (1)**, if the passive-to-active received transition beginning the SOF symbol of the next message occurs between **a** and **b**, the current symbol will be considered a valid end-of-frame (EOF) symbol.

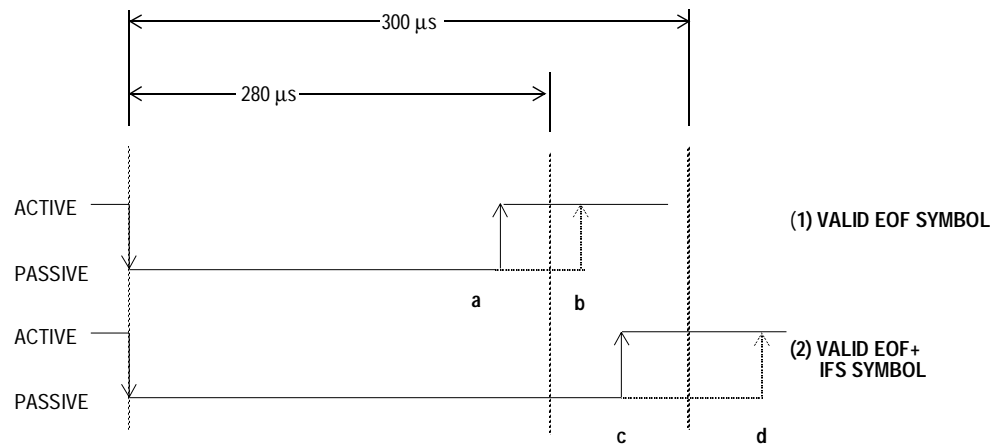

Figure 21-9. J1850 VPW Received Passive EOF and IFS Symbol Times

See **Figure 21-9 (2)**. If the passive-to-active received transition beginning the SOF symbol of the next message occurs between **c** and **d**, the current symbol will be considered a valid EOF symbol followed by a valid inter-frame separation symbol (IFS). All nodes must wait until a valid IFS symbol time has expired before beginning transmission. However, due to variations in clock frequencies and bus loading, some nodes may recognize a valid IFS symbol before others and immediately begin transmitting. Therefore, any time a node waiting to transmit detects a passive-to-active transition once a valid EOF has been detected, it should immediately begin transmission, initiating the arbitration process.

21.5.4.6 Idle Bus

In **Figure 21-9 (2)**, if the passive-to-active received transition beginning the start-of-frame (SOF) symbol of the next message does not occur before **d**, the bus is considered to be idle, and any node wishing to transmit a message may do so immediately.

Byte Data Link Controller-Digital (BDLC-D)

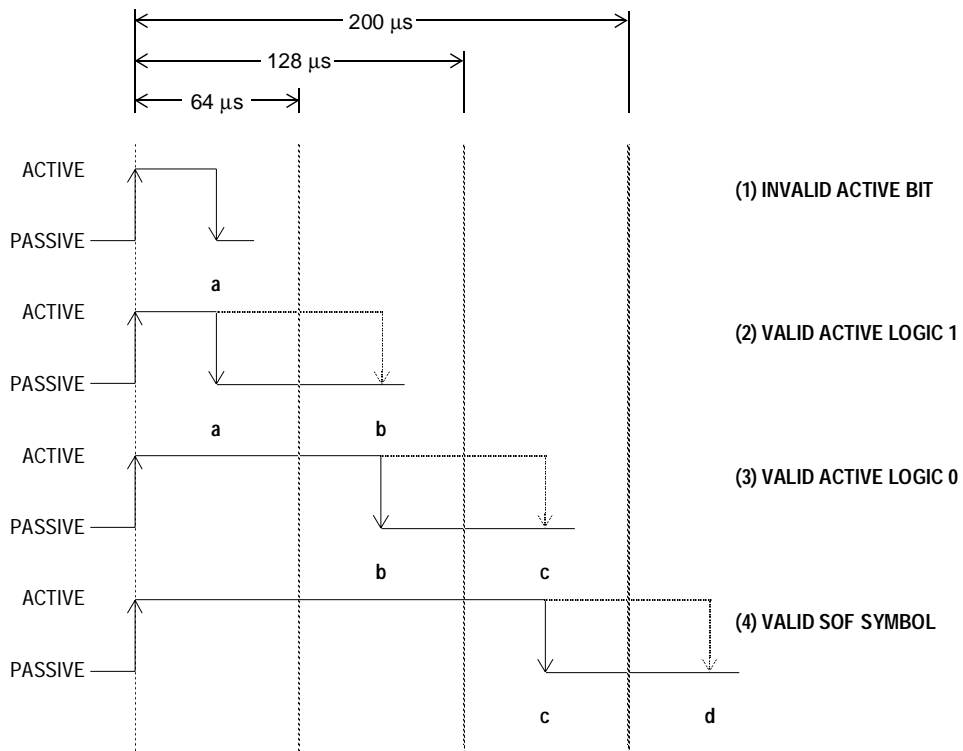

Figure 21-10. J1850 VPW Received Active Symbol Times

21.5.4.7 Invalid Active Bit

In **Figure 21-10 (1)**, if the active-to-passive received transition beginning the next data bit (or symbol) occurs between the passive-to-active transition beginning the current data bit (or symbol) and **a**, the current bit would be invalid.

21.5.4.8 Valid Active Logic 1

In **Figure 21-10 (2)**, if the active-to-passive received transition beginning the next data bit (or symbol) occurs between **a** and **b**, the current bit would be considered a logic 1.

21.5.4.9 Valid Active Logic 0

In **Figure 21-10 (3)**, if the active-to-passive received transition beginning the next data bit (or symbol) occurs between **b** and **c**, the current bit would be considered a logic 0.

21.5.4.10 Valid SOF Symbol

In **Figure 21-10 (4)**, if the active-to-passive received transition beginning the next data bit (or symbol) occurs between **c** and **d**, the current symbol would be considered a valid SOF symbol.

21.5.4.11 Valid BREAK Symbol

In **Figure 21-11**, if the next active-to-passive received transition does not occur until after **e**, the current symbol will be considered a valid BREAK symbol. A BREAK symbol should be followed by a start-of-frame (SOF) symbol beginning the next message to be transmitted onto the J1850 bus. See **21.5.2 J1850 Frame Format** for BDLC response to BREAK symbols.

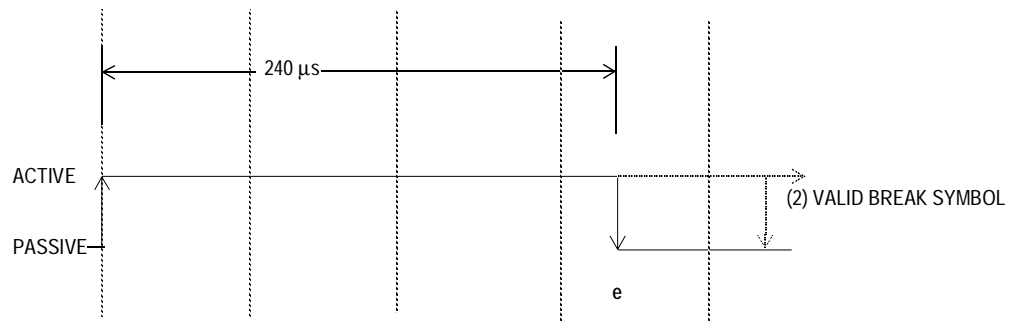

Figure 21-11. J1850 VPW Received BREAK Symbol Times

21.5.5 Message Arbitration

Message arbitration on the J1850 bus is accomplished in a non-destructive manner, allowing the message with the highest priority to be transmitted, while any transmitters which lose arbitration simply stop transmitting and wait for an idle bus to begin transmitting again.

If the BDLC wants to transmit onto the J1850 bus, but detects that another message is in progress, it waits until the bus is idle. However, if multiple nodes begin to transmit in the same synchronization window, message arbitration will occur beginning with the first bit after the SOF symbol and continue with each bit thereafter. If a write to the BDR (for instance, to initiate transmission) occurred on or before

Byte Data Link Controller-Digital (BDLC-D)

104 • t_{BDLC} from the received rising edge, then the BDLC will transmit and arbitrate for the bus. If a CPU write to the BDR occurred after 104 • t_{BDLC} from the detection of the rising edge, then the BDLC will not transmit, but will wait for the next IFS period to expire before attempting to transmit the byte.

The variable pulse-width modulation (VPW) symbols and J1850 bus electrical characteristics are chosen carefully so that a logic 0 (active or passive type) will always dominate over a logic 1 (active or passive type) simultaneously transmitted. Hence, logic 0s are said to be dominant and logic 1s are said to be recessive.

Whenever a node detects a dominant bit on BDRxD when it transmitted a recessive bit, it loses arbitration and immediately stops transmitting. This is known as bitwise arbitration.

Since a logic 0 dominates a logic 1, the message with the lowest value will have the highest priority and will always win arbitration. For instance, a message with priority 000 will win arbitration over a message with priority 011.

This method of arbitration will work no matter how many bits of priority encoding are contained in the message.

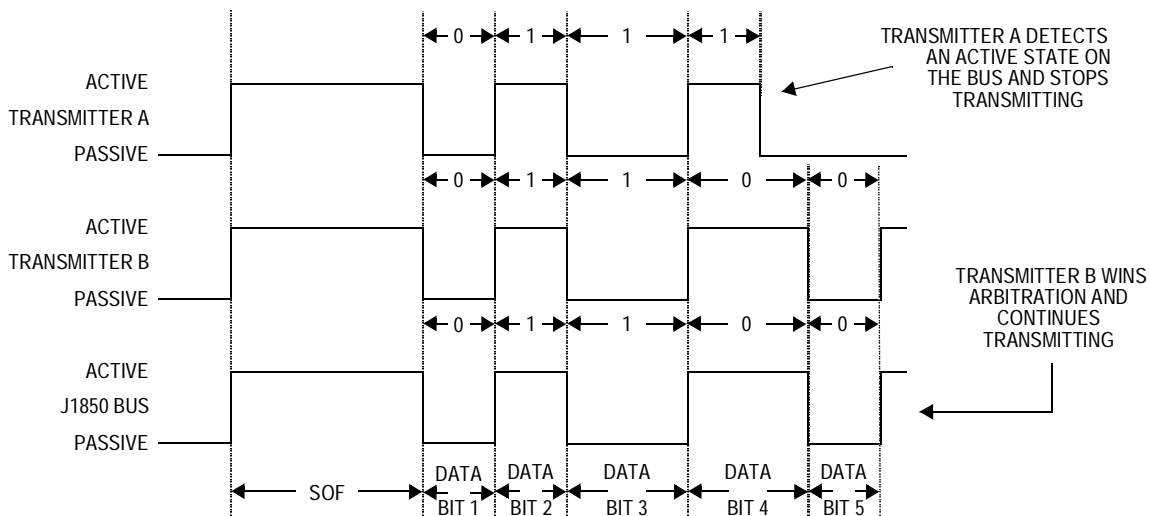

Figure 21-12. J1850 VPW Bitwise Arbitrations

During arbitration, or even throughout the transmitting message, when an opposite bit is detected, transmission is stopped immediately unless it occurs on the 8th bit of a byte. In this case, the BDLC automatically will append up to two extra logic 1 bits and then stop transmitting. These two extra bits will be arbitrated normally and thus will not interfere with another message. The second logic 1 bit will not be sent if the first loses arbitration. If the BDLC has lost arbitration to another valid message, then the two extra logic 1s will not corrupt the current message. However, if the BDLC has lost arbitration due to noise on the bus, then the two extra logic 1s will ensure that the current message will be detected and ignored as a noise-corrupted message.

21.6 BDLC Protocol Handler

The protocol handler is responsible for framing, arbitration, CRC generation/checking, and error detection. The protocol handler conforms to *SAE J1850 Class B Data Communications Network Interface*.

NOTE: *Motorola assumes that the reader is familiar with the J1850 specification before reading this protocol handler description.*

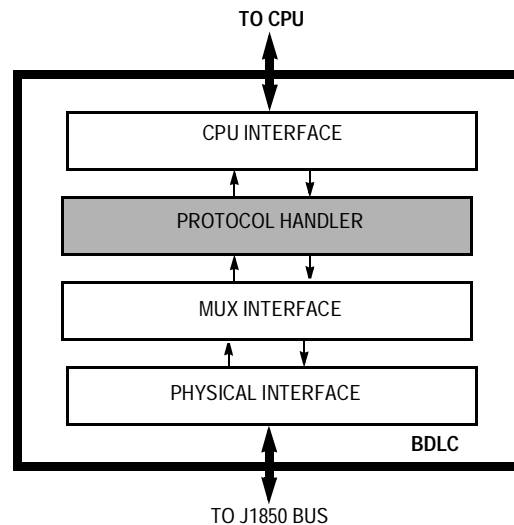

Figure 21-13. BDLC Block Diagram

Byte Data Link Controller-Digital (BDLC-D)

21.6.1 Protocol Architecture

The protocol handler contains the state machine, Rx shadow register, Tx shadow register, Rx shift register, Tx shift register, and loopback multiplexer as shown in **Figure 21-14**.

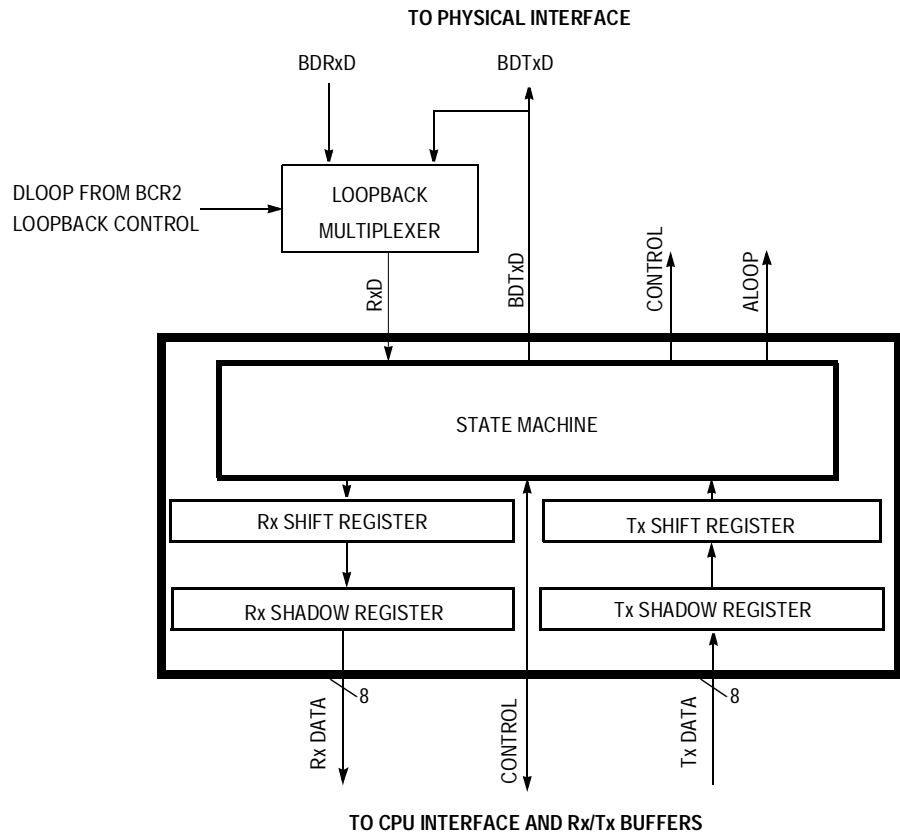

Figure 21-14. BDLC Protocol Handler Outline

21.6.2 Rx and Tx Shift Registers

The Rx shift register gathers received serial data bits from the J1850 bus and makes them available in parallel form to the Rx shadow register. The Tx shift register takes data, in parallel form, from the Tx shadow register and presents it serially to the state machine so that it can be transmitted onto the J1850 bus.

21.6.3 Rx and Tx Shadow Registers

Immediately after the Rx shift register has completed shifting in a byte of data, this data is transferred to the Rx shadow register and RDRF or RXIFR is set (see [21.7.4 BDLC State Vector Register](#)). An interrupt is generated if the interrupt enable bit (IE) in BCR1 is set. After the transfer takes place, this new data byte in the Rx shadow register is available to the CPU interface, and the Rx shift register is ready to shift in the next byte of data. Data in the Rx shadow register must be retrieved by the CPU before it is overwritten by new data from the Rx shift register.

Once the Tx shift register has completed its shifting operation for the current byte, the data byte in the Tx shadow register is loaded into the Tx shift register. After this transfer takes place, the Tx shadow register is ready to accept new data from the CPU when the TDRE flag in the BSVR is set.

21.6.4 Digital Loopback Multiplexer

The digital loopback multiplexer connects RxD to either BDTxD or BDRxD, depending on the state of the DLOOP bit in the BCR2 (see [21.7.3 BDLC Control Register 2](#)).

21.6.5 State Machine

All functions associated with performing the protocol are executed or controlled by the state machine. The state machine is responsible for framing, collision detection, arbitration, CRC generation/checking, and error detection. The following sections describe the BDLC's actions in a variety of situations.

21.6.5.1 4X Mode

The BDLC can exist on the same J1850 bus as modules which use a special 4X (41.6 kbps) mode of J1850 variable pulse width modulation (VPW) operation. The BDLC cannot transmit in 4X mode, but it can receive messages in 4X mode, if the RX4XE bit is set in BCR2. If the

RX4XE bit is not set in the BCR2, any 4X message on the J1850 bus is treated as noise by the BDLC and is ignored.

21.6.5.2 Receiving a Message in Block Mode

Although not a part of the SAE J1850 protocol, the BDLC does allow for a special block mode of operation of the receiver. As far as the BDLC is concerned, a block mode message is simply a long J1850 frame that contains an indefinite number of data bytes. All other features of the frame remain the same, including the SOF, CRC, and EOD symbols.

Another node wishing to send a block mode transmission must first inform all other nodes on the network that this is about to happen. This is usually accomplished by sending a special predefined message.

21.6.5.3 Transmitting a Message in Block Mode

A block mode message is transmitted inherently by simply loading the bytes one by one into the BDR until the message is complete. The programmer should wait until the TDRE flag (see [21.7.4 BDLC State Vector Register](#)) is set prior to writing a new byte of data into the BDR. The BDLC does not contain any predefined maximum J1850 message length requirement.

21.6.5.4 J1850 Bus Errors

The BDLC detects several types of transmit and receive errors which can occur during the transmission of a message onto the J1850 bus.

Transmission Error

If the message transmitted by the BDLC contains invalid bits or framing symbols on non-byte boundaries, this constitutes a transmission error. When a transmission error is detected, the BDLC immediately will cease transmitting. The error condition is reflected in the BSVR (see [Table 21-5](#)). If the interrupt enable bit (IE in BCR1) is set, a CPU interrupt request from the BDLC is generated.

CRC Error

A cyclical redundancy check (CRC) error is detected when the data bytes and CRC byte of a received message are processed and the CRC calculation result is not equal. The CRC code will detect any single and 2-bit errors, as well as all 8-bit burst errors and almost all other types of errors. The CRC error flag (in BSVR) is set when a CRC error is detected (see [21.7.4 BDLC State Vector Register](#)).

Symbol Error

A symbol error is detected when an abnormal (invalid) symbol is detected in a message being received from the J1850 bus. The invalid symbol is set when a symbol error is detected (see [21.7.4 BDLC State Vector Register](#)).

Framing Error

A framing error is detected if an EOD or EOF symbol is detected on a non-byte boundary from the J1850 bus. A framing error also is detected if the BDLC is transmitting the EOD and instead receives an active symbol. The symbol invalid, or the out-of-range flag, is set when a framing error is detected (see [21.7.4 BDLC State Vector Register](#)).

Bus Fault

If a bus fault occurs, the response of the BDLC will depend upon the type of bus fault.

If the bus is shorted to battery, the BDLC will wait for the bus to fall to a passive state before it will attempt to transmit a message. As long as the short remains, the BDLC will never attempt to transmit a message onto the J1850 bus.

If the bus is shorted to ground, the BDLC will see an idle bus, begin to transmit the message, and then detect a transmission error (in BSVR), since the short to ground would not allow the bus to be driven to the active (dominant) SOF state. The BDLC will abort that transmission and wait for the next CPU command to transmit.

Byte Data Link Controller-Digital (BDLC-D)

In any case, if the bus fault is temporary, as soon as the fault is cleared, the BDLC will resume normal operation. If the bus fault is permanent, it may result in permanent loss of communication on the J1850 bus. (See [21.7.4 BDLC State Vector Register](#).)

BREAK — Break

If a BREAK symbol is received while the BDLC is transmitting or receiving, an invalid symbol (in BSVR) interrupt will be generated. Reading the BSVR (see [21.7.4 BDLC State Vector Register](#)) will clear this interrupt condition. The BDLC will wait for the bus to idle, then wait for a start-of-frame (SOF) symbol.

The BDLC cannot transmit a BREAK symbol. It only can receive a BREAK symbol from the J1850 bus.

21.6.5.5 Summary

Table 21-1. BDLC J1850 Bus Error Summary

Error Condition	BDLC Function
Transmission error	For invalid bits or framing symbols on non-byte boundaries, invalid symbol interrupt will be generated. BDLC stops transmission.
Cyclical redundancy check (CRC) error	CRC error interrupt will be generated. The BDLC will wait for EOF.
Invalid symbol: BDLC transmits, but receives invalid bits (noise)	The BDLC will abort transmission immediately. Invalid symbol interrupt will be generated.
Framing error	Invalid symbol interrupt will be generated. The BDLC will wait for end of frame (EOF).
Bus short to V _{DD}	The BDLC will not transmit until the bus is idle. Invalid symbol interrupt will be generated. EOF interrupt also must be seen before another transmission attempt. Depending on length of the short, LOA flag also may be set.
Bus short to GND	Thermal overload will shut down physical interface. Fault condition is seen as invalid symbol flag. EOF interrupt must also be seen before another transmission attempt.
BDLC receives BREAK symbol	Invalid symbol interrupt will be generated. The BDLC will wait for the next valid SOF.

21.7 BDLC CPU Interface

The CPU interface provides the interface between the CPU and the BDLC and consists of these five user registers:

1. BDLC analog and roundtrip delay register (BARD)
2. BDLC control register 1 (BCR1)
3. BDLC control register 2 (BCR2)
4. BDLC state vector register (BSVR)
5. BDLC data register (BDR)

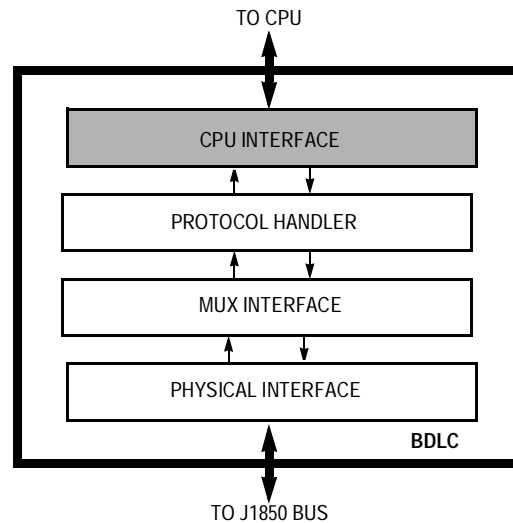

Figure 21-15. BDLC Block Diagram

21.7.1 BDLC Analog and Roundtrip Delay

This register programs the BDLC to compensate for various delays of different external transceivers. The default delay value is 16 μ s. Timing adjustments from 9 μ s to 24 μ s in steps of 1 μ s are available. The BARD register can be written only once after each reset, after which they become read-only bits. The register may be read at any time.

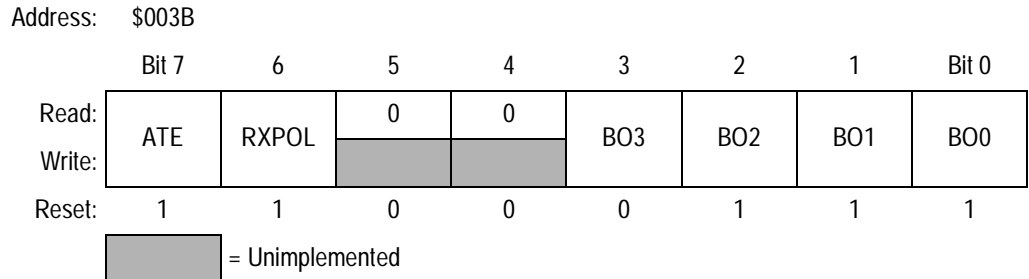

Figure 21-16. BDLC Analog and Roundtrip Delay Register (BARD)

ATE — Analog Transceiver Enable Bit

The analog transceiver enable (ATE) bit is used to select either the on-board or an off-chip analog transceiver.

- 1 = Select on-board analog transceiver
- 0 = Select off-chip analog transceiver

NOTE: This device does not contain an on-board transceiver. This bit should be programmed to a logic 0 for proper operation.

RXPOL — Receive Pin Polarity Bit

The receive pin polarity (RXPOL) bit is used to select the polarity of an incoming signal on the receive pin. Some external analog transceivers invert the receive signal from the J1850 bus before feeding it back to the digital receive pin.

- 1 = Select normal/true polarity; true non-inverted signal from the J1850 bus; for example, the external transceiver does not invert the receive signal
- 0 = Select inverted polarity, where an external transceiver inverts the receive signal from the J1850 bus

BO3–BO0 — BARD Offset Bits

Table 21-2 shows the expected transceiver delay with respect to BARD offset values.

Table 21-2. BDLC Transceiver Delay

BARD Offset Bits BO[3:0]	Corresponding Expected Transceiver's Delays (μs)
0000	9
0001	10
0010	11
0011	12
0100	13
0101	14
0110	15
0111	16
1000	17
1001	18
1010	19
1011	20
1100	21
1101	22
1110	23
1111	24

21.7.2 BDLC Control Register 1

This register is used to configure and control the BDLC.

Address: \$003C

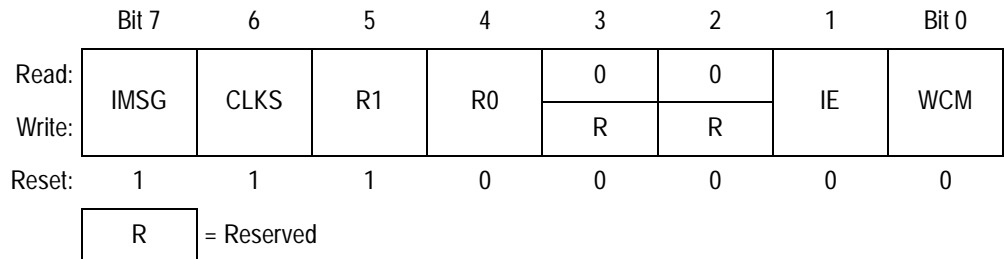

Figure 21-17. BDLC Control Register 1 (BCR1)

IMSG — Ignore Message Bit

This bit is used to disable the receiver until a new start-of-frame (SOF) is detected.

1 = Disable receiver. When set, all BDLC interrupt requests will be masked (except \$20 in BSVR) and the status bits will be held in their reset state. If this bit is set while the BDLC is receiving a message, the rest of the incoming message will be ignored.

0 = Enable receiver. This bit is cleared automatically by the reception of an SOF symbol or a BREAK symbol. It will then generate interrupt requests and will allow changes of the status register to occur. However, these interrupts may still be masked by the interrupt enable (IE) bit.

CLKS — Clock Bit

For J1850 bus communications to take place, the nominal BDLC operating frequency (f_{BDLC}) must always be 1.048576 MHz or 1 MHz. The CLKS register bit allows the user to select the frequency (1.048576 MHz or 1 MHz) used to automatically adjust symbol timing.

1 = Binary frequency (1.048576 MHz) selected for f_{BDLC}

0 = Integer frequency (1 MHz) selected for f_{BDLC}

R1 and R0 — Rate Select Bits

These bits determine the amount by which the frequency of the MCU CGMXCLK signal is divided to form the MUX interface clock (f_{BDLC}) which defines the basic timing resolution of the MUX interface. They may be written only once after reset, after which they become read-only bits.

The nominal frequency of f_{BDLC} must always be 1.048576 MHz or 1.0 MHz for J1850 bus communications to take place. Hence, the value programmed into these bits is dependent on the chosen MCU system clock frequency per [Table 21-3](#).

Table 21-3. BDLC Rate Selection

f_{XCLK} Frequency	R1	R0	Division	f_{BDLC}
1.049 MHz	0	0	1	1.049 MHz
2.097 MHz	0	1	2	1.049 MHz
4.194 MHz	1	0	4	1.049 MHz
8.389 MHz	1	1	8	1.049 MHz
1.000 MHz	0	0	1	1.00 MHz
2.000 MHz	0	1	2	1.00 MHz
4.000 MHz	1	0	4	1.00 MHz
8.000 MHz	1	1	8	1.00 MHz

IE— Interrupt Enable Bit

This bit determines whether the BDLC will generate CPU interrupt requests in run mode. It does not affect CPU interrupt requests when exiting the BDLC stop or BDLC wait modes. Interrupt requests will be maintained until all of the interrupt request sources are cleared by performing the specified actions upon the BDLC's registers. Interrupts that were pending at the time that this bit is cleared may be lost.

- 1 = Enable interrupt requests from BDLC
- 0 = Disable interrupt requests from BDLC

If the programmer does not wish to use the interrupt capability of the BDLC, the BDLC state vector register (BSVR) can be polled periodically by the programmer to determine BDLC states. See [21.7.4 BDLC State Vector Register](#) for a description of the BSVR.

WCM — Wait Clock Mode Bit

This bit determines the operation of the BDLC during CPU wait mode. See [21.8.2 Stop Mode](#) and [21.8.1 Wait Mode](#) for more details on its use.

- 1 = Stop BDLC internal clocks during CPU wait mode
- 0 = Run BDLC internal clocks during CPU wait mode

21.7.3 BDLC Control Register 2

This register controls transmitter operations of the BDLC. It is recommended that BSET and BCLR instructions be used to manipulate data in this register to ensure that the register’s content does not change inadvertently.

Address: \$003D

	Bit 7	6	5	4	3	2	1	Bit 0
Read:	ALOOP	DLOOP	RX4XE	NBFS	TEOD	TSIFR	TMIFR1	TMIFR0
Write:								
Reset:	1	1	0	0	0	0	0	0

Figure 21-18. BDLC Control Register 2 (BCR2)

ALOOP — Analog Loopback Mode Bit

This bit determines whether the J1850 bus will be driven by the analog physical interface’s final drive stage. The programmer can use this bit to reset the BDLC state machine to a known state after the off-chip analog transceiver is placed in loopback mode. When the user clears ALOOP, to indicate that the off-chip analog transceiver is no longer in loopback mode, the BDLC waits for an EOF symbol before attempting to transmit. Most transceivers have the ALOOP feature available.

- 1 = Input to the analog physical interface’s final drive stage is looped back to the BDLC receiver. The J1850 bus is not driven.
- 0 = The J1850 bus will be driven by the BDLC. After the bit is cleared, the BDLC requires the bus to be idle for a minimum of end-of-frame symbol time (t_{TRV4}) before message reception or a minimum of inter-frame symbol time (t_{TRV6}) before message transmission. See [24.15 BDLC Receiver VPW Symbol Timings](#).

DLOOP — Digital Loopback Mode Bit

This bit determines the source to which the digital receive input (BDRxD) is connected and can be used to isolate bus fault conditions (see [Figure 21-14](#)). If a fault condition has been detected on the bus, this control bit allows the programmer to connect the digital transmit output to the digital receive input. In this configuration, data sent from the transmit buffer will be reflected back into the receive buffer. If no faults exist in the BDLC, the fault is in the physical interface block or elsewhere on the J1850 bus.

1 = When set, BDRxD is connected to BDTxD. The BDLC is now in digital loopback mode.

0 = When cleared, BDTxD is not connected to BDRxD. The BDLC is taken out of digital loopback mode and can now drive or receive the J1850 bus normally (given ALOOP is not set). After writing DLOOP to 0, the BDLC requires the bus to be idle for a minimum of end-of-frame symbol (t_{tv4}) time before allowing a reception of a message. The BDLC requires the bus to be idle for a minimum of inter-frame separator symbol (t_{tv6}) time before allowing any message to be transmitted.

RX4XE — Receive 4X Enable Bit

This bit determines if the BDLC operates at normal transmit and receive speed (10.4 kbps) or receive only at 41.6 kbps. This feature is useful for fast downloading of data into a J1850 node for diagnostic or factory programming of the node.

1 = When set, the BDLC is put in 4X receive-only operation.

0 = When cleared, the BDLC transmits and receives at 10.4 kbps. Reception of a BREAK symbol automatically clears this bit and sets BDLC state vector register (BSVR) to \$001C.

NBFS — Normalization Bit Format Select Bit

This bit controls the format of the normalization bit (NB) (see [Figure 21-19](#)). SAE J1850 strongly encourages using an active long (logic 0) for in-frame responses containing cyclical redundancy check (CRC) and an active short (logic 1) for in-frame responses without CRC.

1 = NB that is received or transmitted is a 0 when the response part of an in-frame response (IFR) ends with a CRC byte. NB that is received or transmitted is a 1 when the response part of an in-frame response (IFR) does not end with a CRC byte.

0 = NB that is received or transmitted is a 1 when the response part of an in-frame response (IFR) ends with a CRC byte. NB that is received or transmitted is a 0 when the response part of an in-frame response (IFR) does not end with a CRC byte.

TEOD — Transmit End-of-Data Bit

This bit is set by the programmer to indicate the end of a message is being sent by the BDLC. It will append an 8-bit CRC after completing transmission of the current byte. This bit also is used to end an in-frame response (IFR). If the transmit shadow register is full when TEOD is set, the CRC byte will be transmitted after the current byte in the Tx shift register and the byte in the Tx shadow register have been transmitted. (See [21.6.3 Rx and Tx Shadow Registers](#) for a description of the transmit shadow register.) Once TEOD is set, the transmit data register empty flag (TDRE) in the BDLC state vector register (BSVR) is cleared to allow lower priority interrupts to occur. (See [21.7.4 BDLC State Vector Register](#).)

1 = Transmit end-of-data (EOD) symbol

0 = The TEOD bit will be cleared automatically at the rising edge of the first CRC bit that is sent or if an error is detected. When TEOD is used to end an IFR transmission, TEOD is cleared when the BDLC receives back a valid EOD symbol or an error condition occurs.

TSIFR, TMIFR1, and TMIFR0 — Transmit In-Frame Response Control Bits

These three bits control the type of in-frame response being sent. The programmer should not set more than one of these control bits to a 1 at any given time. However, if more than one of these three control bits are set to 1, the priority encoding logic will force these register bits to a known value as shown in [Table 21-4](#). For example, if 011 is written to TSIFR, TMIFR1, and TMIFR0, then internally they will be encoded as 010. However, when these bits are read back, they will read 011.

Table 21-4. BDLC Transmit In-Frame Response Control Bit Priority Encoding

Write/Read TSIFR	Write/Read TMIFR1	Write/Read TMIFR0	Actual TSIFR	Actual TMIFR1	Actual TMIFR0
0	0	0	0	0	0
1	X	X	1	0	0
0	1	X	0	1	0
0	0	1	0	0	1

The BDLC supports the in-frame response (IFR) feature of J1850 by setting these bits correctly. The four types of J1850 IFR are shown in the following figure. The purpose of the in-frame response modes is to allow multiple nodes to acknowledge receipt of the data by responding with their personal ID or physical address in a concatenated manner after they have seen the EOD symbol. If transmission arbitration is lost by a node while sending its response, it continues to transmit its ID/address until observing its unique byte in the response stream. For VPW modulation, the first bit of the IFR is always passive; therefore, an active normalization bit must be generated by the responder and sent prior to its ID/address byte. When there are multiple responders on the J1850 bus, only one normalization bit is sent which assists all other transmitting nodes to sync their responses.

Byte Data Link Controller-Digital (BDLC-D)

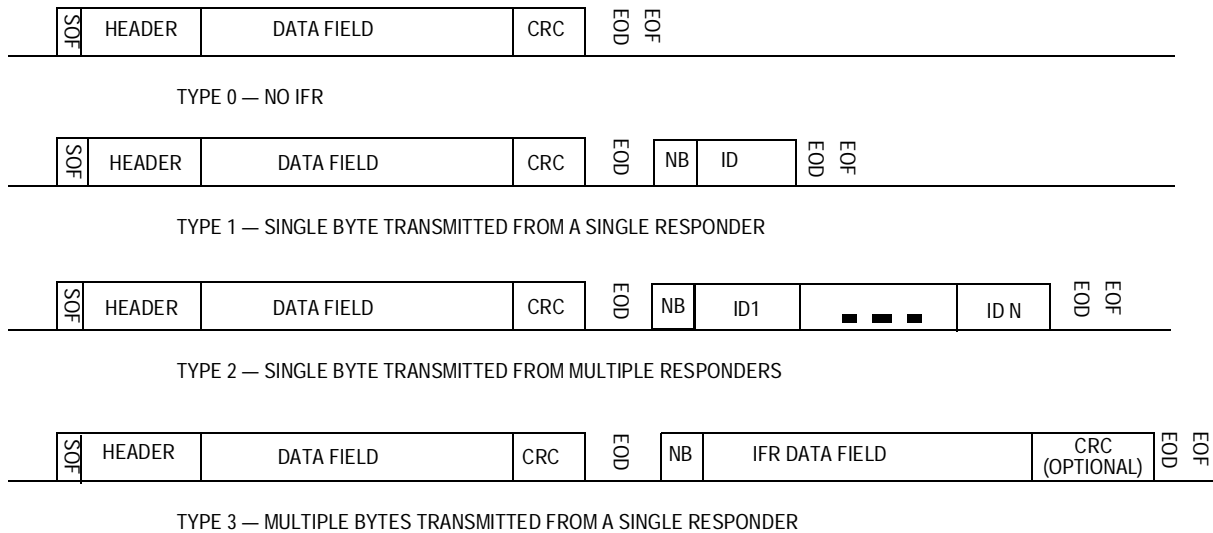

NB = Normalization bit
 ID = Identifier, usually the physical address of the responder(s)

Figure 21-19. Types of In-Frame Response (IFR)

TSIFR — Transmit Single Byte IFR with No CRC (Type 1 or 2) Bit

The TSIFR bit is used to request the BDLC to transmit the byte in the BDLC data register (BDR) as a single byte IFR with no CRC. Typically, the byte transmitted is a unique identifier or address of the transmitting (responding) node. See [Figure 21-19](#).

- 1 = If this bit is set prior to a valid EOD being received with no CRC error, once the EOD symbol has been received the BDLC will attempt to transmit the appropriate normalization bit followed by the byte in the BDR.
- 0 = The TSIFR bit will be cleared automatically, once the BDLC has successfully transmitted the byte in the BDR onto the bus, or TEOD is set, or an error is detected on the bus.

If the programmer attempts to set the TSIFR bit immediately after the EOD symbol has been received from the bus, the TSIFR bit will remain in the reset state and no attempt will be made to transmit the IFR byte.

If a loss of arbitration occurs when the BDLC attempts to transmit and after the IFR byte winning arbitration completes transmission, the BDLC

will again attempt to transmit the BDR (with no normalization bit). The BDLC will continue transmission attempts until an error is detected on the bus, or TEOD is set, or the BDLC transmission is successful.

If loss of arbitration occurs in the last two bits of the IFR byte, two additional 1 bits **will not** be sent out because the BDLC will attempt to retransmit the byte in the transmit shift register after the IRF byte winning arbitration completes transmission.

TMIFR1 — Transmit Multiple Byte IFR with CRC (Type 3) Bit

The TMIFR1 bit requests the BDLC to transmit the byte in the BDLC data register (BDR) as the first byte of a multiple byte IFR with CRC or as a single byte IFR with CRC. Response IFR bytes are still subject to J1850 message length maximums (see **21.5.2 J1850 Frame Format**). See **Figure 21-19**.

1 = If this bit is set prior to a valid EOD being received with no CRC error, once the EOD symbol has been received, the BDLC will attempt to transmit the appropriate normalization bit followed by IFR bytes. The programmer should set TEOD after the last IFR byte has been written into the BDR. After TEOD has been set and the last IFR byte has been transmitted, the CRC byte is transmitted.

0 = The TMIFR1 bit will be cleared automatically, once the BDLC has successfully transmitted the CRC byte and EOD symbol, by the detection of an error on the multiplex bus or by a transmitter underrun caused when the programmer does not write another byte to the BDR after the TDRE interrupt.

If the TMIFR1 bit is set, the BDLC will attempt to transmit the normalization symbol followed by the byte in the BDR. After the byte in the BDR has been loaded into the transmit shift register, a TDRE interrupt (see **21.7.4 BDLC State Vector Register**) will occur similar to the main message transmit sequence. The programmer should then load the next byte of the IFR into the BDR for transmission. When the last byte of the IFR has been loaded into the BDR, the programmer should set the TEOD bit in the BDLC control register 2 (BCR2). This will instruct the BDLC to transmit a CRC byte once the byte in the BDR is transmitted, and then transmit an EOD symbol, indicating the end of the IFR portion of the message frame.

However, if the programmer wishes to transmit a single byte followed by a CRC byte, the programmer should load the byte into the BDR before the EOD symbol has been received, and then set the TMIFR1 bit. Once the TDRE interrupt occurs, the programmer should then set the TEOD bit in the BCR2. This will result in the byte in the BDR being the only byte transmitted before the IFR CRC byte, and no TDRE interrupt will be generated.

If the programmer attempts to set the TMIFR1 bit immediately after the EOD symbol has been received from the bus, the TMIFR1 bit will remain in the reset state, and no attempt will be made to transmit an IFR byte.

If a loss of arbitration occurs when the BDLC is transmitting any byte of a multiple byte IFR, the BDLC will go to the loss of arbitration state, set the appropriate flag, and cease transmission.

If the BDLC loses arbitration during the IFR, the TMIFR1 bit will be cleared and **no attempt** will be made to retransmit the byte in the BDR. If loss of arbitration occurs in the last two bits of the IFR byte, two additional 1 bits will be sent out.

NOTE: *The extra logic 1s are an enhancement to the J1850 protocol which forces a byte boundary condition fault. This is helpful in preventing noise on the J1850 bus from corrupting a message.*

TMIFR0 — Transmit Multiple Byte IFR without CRC (Type 3) Bit

The TMIFR0 bit is used to request the BDLC to transmit the byte in the BDLC data register (BDR) as the first byte of a multiple byte IFR without CRC. Response IFR bytes are still subject to J1850 message length maximums (see [21.5.2 J1850 Frame Format](#)).

See [Figure 21-19](#).

1 = If this bit is set prior to a valid EOD being received with no CRC error, once the EOD symbol has been received, the BDLC will attempt to transmit the appropriate normalization bit followed by IFR bytes. The programmer should set TEOD after the last IFR byte has been written into the BDR. After TEOD has been set, the last IFR byte to be transmitted will be the last byte which was written into the BDR.

0 = The TMIFR0 bit will be cleared automatically, once the BDLC has successfully transmitted the EOD symbol, by the detection of an error on the multiplex bus or by a transmitter underrun caused when the programmer does not write another byte to the BDR after the TDRE interrupt.

If the TMIFR0 bit is set, the BDLC will attempt to transmit the normalization symbol followed by the byte in the BDR. After the byte in the BDR has been loaded into the transmit shift register, a TDRE interrupt (see [21.7.4 BDLC State Vector Register](#)) will occur similar to the main message transmit sequence. The programmer should then load the next byte of the IFR into the BDR for transmission. When the last byte of the IFR has been loaded into the BDR, the programmer should set the TEOD bit in the BCR2. This will instruct the BDLC to transmit an EOD symbol once the byte in the BDR is transmitted, indicating the end of the IFR portion of the message frame. The BDLC will not append a CRC when the TMIFR0 is set.

If the programmer attempts to set the TMIFR0 bit after the EOD symbol has been received from the bus, the TMIFR0 bit will remain in the reset state, and no attempt will be made to transmit an IFR byte.

If a loss of arbitration occurs when the BDLC is transmitting, the TMIFR0 bit will be cleared, and **no attempt** will be made to retransmit the byte in the BDR. If loss of arbitration occurs in the last two bits of the IFR byte, two additional 1 bits (active short bits) will be sent out.

NOTE: The extra logic 1s are an enhancement to the J1850 protocol which forces a byte boundary condition fault. This is helpful in preventing noise onto the J1850 bus from a corrupted message.

Byte Data Link Controller-Digital (BDLC-D)

21.7.4 BDLC State Vector Register

This register is provided to substantially decrease the CPU overhead associated with servicing interrupts while under operation of a multiplex protocol. It provides an index offset that is directly related to the BDLC's current state, which can be used with a user-supplied jump table to rapidly enter an interrupt service routine. This eliminates the need for the user to maintain a duplicate state machine in software.

Address: \$003E

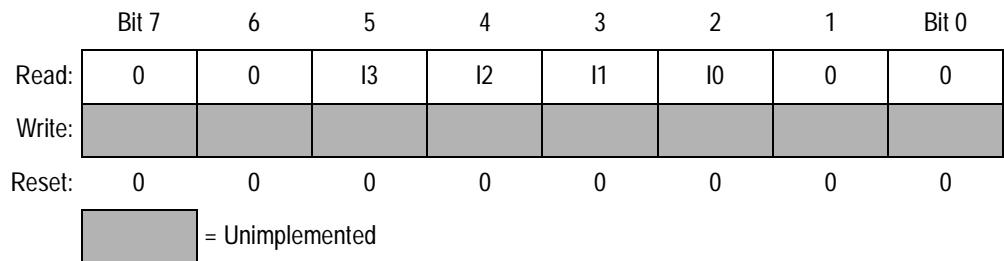

Figure 21-20. BDLC State Vector Register (BSVR)

I0, I1, I2, and I3 — Interrupt Source Bits

These bits indicate the source of the interrupt request that currently is pending. The encoding of these bits are listed in Table 21-5.

Table 21-5. BDLC Interrupt Sources

BSVR	I3	I2	I1	I0	Interrupt Source	Priority
\$00	0	0	0	0	No interrupts pending	0 (lowest)
\$04	0	0	0	1	Received EOF	1
\$08	0	0	1	0	Received IFR byte (RXIFR)	2
\$0C	0	0	1	1	BDLC Rx data register full (RDRF)	3
\$10	0	1	0	0	BDLC Tx data register empty (TDRE)	4
\$14	0	1	0	1	Loss of arbitration	5
\$18	0	1	1	0	Cyclical redundancy check (CRC) error	6
\$1C	0	1	1	1	Symbol invalid or out of range	7
\$20	1	0	0	0	Wakeup	8 (highest)

Bits I0, I1, I2, and I3 are cleared by a read of the BSVR except when the BDLC data register needs servicing (RDRF, RXIFR, or TDRE conditions). RXIFR and RDRF can be cleared only by a read of the BSVR followed by a read of the BDLC data register (BDR). TDRE can either be cleared by a read of the BSVR followed by a write to the BDLC BDR or by setting the TEOD bit in BCR2.

Upon receiving a BDLC interrupt, the user can read the value within the BSVR, transferring it to the CPU's index register. The value can then be used to index into a jump table, with entries four bytes apart, to quickly enter the appropriate service routine. For example:

```

Service      LDX   BSVR      Fetch State Vector Number
              JMP   JMPTAB,X  Enter service routine,
*              (must end in RTI)
*
JMPTAB       JMP   SERVE0    Service condition #0
              NOP
              JMP   SERVE1    Service condition #1
              NOP
              JMP   SERVE2    Service condition #2
              NOP
*
              JMP   SERVE8    Service condition #8
              END
    
```

NOTE: *The NOPs are used only to align the JMPs onto 4-byte boundaries so that the value in the BSVR can be used intact. Each of the service routines must end with a return-from-interrupt (RTI) instruction to guarantee correct continued operation of the device. Note also that the first entry can be omitted since it corresponds to no interrupt occurring.*

The service routines should clear all of the sources that are causing the pending interrupts. Note that the clearing of a high priority interrupt may still leave a lower priority interrupt pending, in which case bits I0, I1, and I2 of the BSVR will then reflect the source of the remaining interrupt request.

If fewer states are used or if a different software approach is taken, the jump table can be made smaller or omitted altogether.

21.7.5 BDLC Data Register

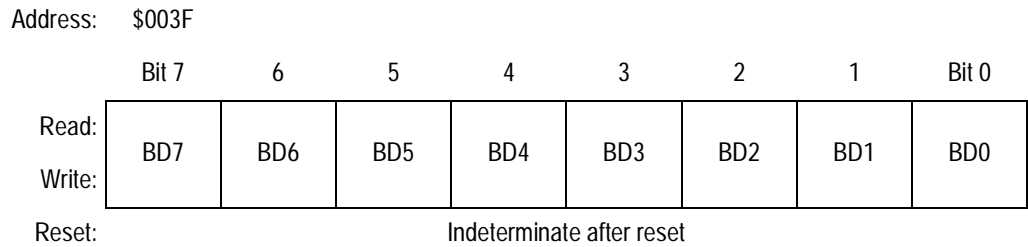

Figure 21-21. BDLC Data Register (BDR)

This register is used to pass the data to be transmitted to the J1850 bus from the CPU to the BDLC. It is also used to pass data received from the J1850 bus to the CPU. Each data byte (after the first one) should be written only after a Tx data register empty (TDRE) state is indicated in the BSVR.

Data read from this register will be the last data byte received from the J1850 bus. This received data should only be read after an Rx data register full (RDRF) interrupt has occurred. See [21.7.4 BDLC State Vector Register](#).

The BDR is double buffered via a transmit shadow register and a receive shadow register. After the byte in the transmit shift register has been transmitted, the byte currently stored in the transmit shadow register is loaded into the transmit shift register. Once the transmit shift register has shifted the first bit out, the TDRE flag is set, and the shadow register is ready to accept the next data byte. The receive shadow register works similarly. Once a complete byte has been received, the receive shift register stores the newly received byte into the receive shadow register. The RDRF flag is set to indicate that a new byte of data has been received. The programmer has one BDLC byte reception time to read the shadow register and clear the RDRF flag before the shadow register is overwritten by the newly received byte.

To abort an in-progress transmission, the programmer should stop loading data into the BDR. This will cause a transmitter underrun error and the BDLC automatically will disable the transmitter on the next non-byte boundary. This means that the earliest a transmission can be

halted is after at least one byte plus two extra logic 1s have been transmitted. The receiver will pick this up as an error and relay it in the state vector register as an invalid symbol error.

NOTE: *The extra logic 1s are an enhancement to the J1850 protocol which forces a byte boundary condition fault. This is helpful in preventing noise on the J1850 bus from corrupting a message.*

21.8 Low-Power Modes

This subsection describes wait mode and stop mode.

21.8.1 Wait Mode

This power-conserving mode is entered automatically from run mode whenever the CPU executes a WAIT instruction and the WCM bit in BDLC control register 1 (BCR1) is previously clear. In BDLC wait mode, the BDLC cannot drive any data.

A subsequent successfully received message, including one that is in progress at the time that this mode is entered, will cause the BDLC to wake up and generate a CPU interrupt request if the interrupt enable (IE) bit in the BDLC control register 1 (BCR1) is previously set (see [21.7.2 BDLC Control Register 1](#) for a better understanding of IE). This results in less of a power saving, but the BDLC is guaranteed to receive correctly the message which woke it up, since the BDLC internal operating clocks are kept running.

NOTE: *Ensuring that all transmissions are complete or aborted before putting the BDLC into wait mode is important.*

21.8.2 Stop Mode

This power-conserving mode is entered automatically from run mode whenever the CPU executes a STOP instruction or if the CPU executes a WAIT instruction and the WCM bit in the BDLC control register 1 (BCR1) is previously set. This is the lowest power mode that the BDLC can enter.

A subsequent passive-to-active transition on the J1850 bus will cause the BDLC to wake up and generate a non-maskable CPU interrupt request. When a STOP instruction is used to put the BDLC in stop mode, the BDLC is not guaranteed to correctly receive the message which woke it up, since it may take some time for the BDLC internal operating clocks to restart and stabilize. If a WAIT instruction is used to put the BDLC in stop mode, the BDLC is guaranteed to correctly receive the byte which woke it up, if and only if an end-of-frame (EOF) has been detected prior to issuing the WAIT instruction by the CPU. Otherwise, the BDLC will not correctly receive the byte that woke it up.

If this mode is entered while the BDLC is receiving a message, the first subsequent received edge will cause the BDLC to wake up immediately, generate a CPU interrupt request, and wait for the BDLC internal operating clocks to restart and stabilize before normal communications can resume. Therefore, the BDLC is not guaranteed to receive that message correctly.

NOTE: *It is important to ensure that all transmissions are complete or aborted prior to putting the BDLC into stop mode.*

Section 22. Timer Interface Module A (TIMA-6)

22.1 Contents

22.2	Introduction	376
22.3	Features	376
22.4	Functional Description	380
22.4.1	TIMA Counter Prescaler	380
22.4.2	Input Capture	381
22.4.3	Output Compare	382
22.4.3.1	Unbuffered Output Compare	382
22.4.3.2	Buffered Output Compare	383
22.4.4	Pulse-Width Modulation (PWM)	385
22.4.4.1	Unbuffered PWM Signal Generation	386
22.4.4.2	Buffered PWM Signal Generation	387
22.4.4.3	PWM Initialization	388
22.5	Interrupts	390
22.6	Low-Power Modes	390
22.6.1	Wait Mode	390
22.6.2	Stop Mode	390
22.7	TIMA During Break Interrupts	391
22.8	I/O Signals	391
22.8.1	TIMA Clock Pin (PTD6/ATD14/TCLK)	392
22.8.2	TIMA Channel I/O Pins (PTF3–PTF0/TACH2 and PTE3/TACH1–PTE2/TACH0)	392
22.9	I/O Registers	392
22.9.1	TIMA Status and Control Register	393
22.9.2	TIMA Counter Registers	395
22.9.3	TIMA Counter Modulo Registers	396
22.9.4	TIMA Channel Status and Control Registers	397
22.9.5	TIMA Channel Registers	402

22.2 Introduction

This section describes the timer interface module (TIMA). The TIMA is a 6-channel timer that provides a timing reference with input capture, output compare, and pulse-width-modulation functions. **Figure 22-1** is a block diagram of the TIMA.

22.3 Features

Features of the TIMA include:

- Six input capture/output compare channels:
 - Rising-edge, falling-edge, or any-edge input capture trigger
 - Set, clear, or toggle output compare action
- Buffered and unbuffered pulse-width-modulation (PWM) signal generation
- Programmable TIMA clock input:
 - 7-frequency internal bus clock prescaler selection
 - External TIMA clock input (4-MHz maximum frequency)
- Free-running or modulo up-count operation
- Toggle any channel pin on overflow
- TIMA counter stop and reset bits

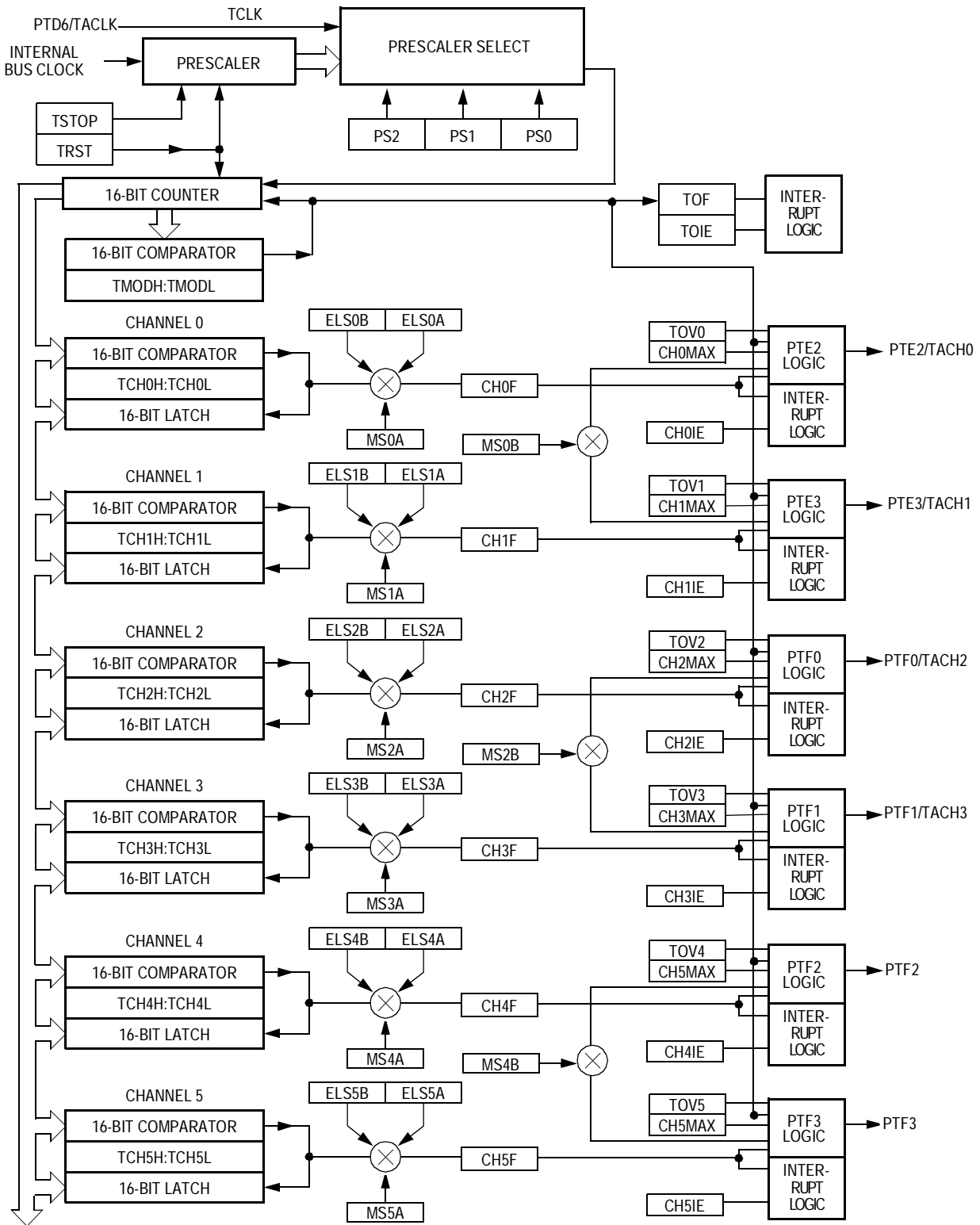

Figure 22-1. TIMA Block Diagram

Timer Interface Module A (TIMA-6)

Addr.	Register Name		Bit 7	6	5	4	3	2	1	Bit 0
\$0020	Timer A Status and Control Register (TASC) See page 393.	Read:	TOF	TOIE	TSTOP	0	0	PS2	PS1	PS0
		Write:	0			TRST	R			
		Reset:	0	0	1	0	0	0	0	0
\$0021	Unimplemented									
\$0022	Timer A Counter Register High (TACNTH) See page 395.	Read:	Bit 15	14	13	12	11	10	9	Bit 8
		Write:	R	R	R	R	R	R	R	R
		Reset:	0	0	0	0	0	0	0	0
\$0023	Timer A Counter Register Low (TACNTL) See page 395.	Read:	Bit 7	6	5	4	3	2	1	Bit 0
		Write:	R	R	R	R	R	R	R	R
		Reset:	0	0	0	0	0	0	0	0
\$0024	Timer A Modulo Register High (TAMODH) See page 396.	Read:	Bit 15	14	13	12	11	10	9	Bit 8
		Write:								
		Reset:	1	1	1	1	1	1	1	1
\$0025	Timer A Modulo Register Low (TAMODL) See page 396.	Read:	Bit 7	6	5	4	3	2	1	Bit 0
		Write:								
		Reset:	1	1	1	1	1	1	1	1
\$0026	Timer A Channel 0 Status and Control Register (TASC0) See page 397.	Read:	CH0F	CH0IE	MS0B	MS0A	ELS0B	ELS0A	TOV0	CH0MAX
		Write:	0							
		Reset:	0	0	0	0	0	0	0	0
\$0027	Timer A Channel 0 Register High (TACH0H) See page 403.	Read:	Bit 15	14	13	12	11	10	9	Bit 8
		Write:								
		Reset:	Indeterminate after reset							
\$0028	Timer A Channel 0 Register Low (TACH0L) See page 403.	Read:	Bit 7	6	5	4	3	2	1	Bit 0
		Write:								
		Reset:	Indeterminate after reset							
\$0029	Timer A Channel 1 Status and Control Register (TASC1) See page 397.	Read:	CH1F	CH1IE	0	MS1A	ELS1B	ELS1A	TOV1	CH1MAX
		Write:	0		R					
		Reset:	0	0	0	0	0	0	0	0

= Unimplemented
 = Reserved

Figure 22-2. TIMA I/O Register Summary (Sheet 1 of 3)

Addr.	Register Name	Bit 7	6	5	4	3	2	1	Bit 0	
\$002A	Timer A Channel 1 Register High (TACH1H) See page 403.	Read:	Bit 15	14	13	12	11	10	9	Bit 8
		Write:								
		Reset:	Indeterminate after reset							
\$002B	Timer A Channel 1 Register Low (TACH1L) See page 403.	Read:	Bit 7	6	5	4	3	2	1	Bit 0
		Write:								
		Reset:	Indeterminate after reset							
\$002C	Timer A Channel 2 Status and Control Register (TASC2) See page 397.	Read:	CH2F	CH2IE	MS2B	MS2A	ELS2B	ELS2A	TOV2	CH2MAX
		Write:	0							
		Reset:	0	0	0	0	0	0	0	0
\$002D	Timer A Channel 2 Register High (TACH2H) See page 403.	Read:	Bit 15	14	13	12	11	10	9	Bit 8
		Write:								
		Reset:	Indeterminate after reset							
\$002E	Timer A Channel 2 Register Low (TACH2L) See page 403.	Read:	Bit 7	6	5	4	3	2	1	Bit 0
		Write:								
		Reset:	Indeterminate after reset							
\$002F	Timer A Channel 3 Status and Control Register (TASC3) See page 397.	Read:	CH3F	CH3IE	0	MS3A	ELS3B	ELS3A	TOV3	CH3MAX
		Write:	0		R					
		Reset:	0	0	0	0	0	0	0	0
\$0030	Timer A Channel 3 Register High (TACH3H) See page 403.	Read:	Bit 15	14	13	12	11	10	9	Bit 8
		Write:								
		Reset:	Indeterminate after reset							
\$0031	Timer A Channel 3 Register Low (TACH3L) See page 403.	Read:	Bit 7	6	5	4	3	2	1	Bit 0
		Write:								
		Reset:	Indeterminate after reset							
\$0032	Timer A Channel 4 Status and Control Register (TASC4) See page 397.	Read:	CH4F	CH4IE	MS4B	MS4A	ELS4B	ELS4A	TOV4	CH4MAX
		Write:	0							
		Reset:	0	0	0	0	0	0	0	0
\$0033	Timer A Channel 4 Register High (TACH4H) See page 403.	Read:	Bit 15	14	13	12	11	10	9	Bit 8
		Write:								
		Reset:	Indeterminate after reset							

= Unimplemented
 R = Reserved

Figure 22-2. TIMA I/O Register Summary (Sheet 2 of 3)

Timer Interface Module A (TIMA-6)

Addr.	Register Name	Bit 7	6	5	4	3	2	1	Bit 0	
\$0034	Timer A Channel 4 Register Low (TACH4L) See page 403.	Read:	Bit 7	6	5	4	3	2	1	Bit 0
		Write:	Bit 7	6	5	4	3	2	1	Bit 0
		Reset:	Indeterminate after reset							
\$0035	Timer A Channel 5 Status and Control Register (TASC5) See page 397.	Read:	CH5F	CH5IE	0	MS5A	ELS5B	ELS5A	TOV5	CH5MAX
		Write:	0		R					
		Reset:	0	0	0	0	0	0	0	0
\$0036	Timer A Channel 5 Register High (TACH5H) See page 403.	Read:	Bit 15	14	13	12	11	10	9	Bit 8
		Write:	Bit 15	14	13	12	11	10	9	Bit 8
		Reset:	Indeterminate after reset							
\$0037	Timer A Channel 5 Register Low (TACH5L) See page 403.	Read:	Bit 7	6	5	4	3	2	1	Bit 0
		Write:	Bit 7	6	5	4	3	2	1	Bit 0
		Reset:	Indeterminate after reset							

= Unimplemented
 R = Reserved

Figure 22-2. TIMA I/O Register Summary (Sheet 3 of 3)

22.4 Functional Description

Figure 22-1 shows the TIMA structure. The central component of the TIMA is the 16-bit TIMA counter that can operate as a free-running counter or a modulo up-counter. The TIMA counter provides the timing reference for the input capture and output compare functions. The TIMA counter modulo registers, TAMODH–TAMODL, control the modulo value of the TIMA counter. Software can read the TIMA counter value at any time without affecting the counting sequence.

The six TIMA channels are programmable independently as input capture or output compare channels.

22.4.1 TIMA Counter Prescaler

The TIMA clock source can be one of the seven prescaler outputs or the TIMA clock pin, PTD6/TACLK. The prescaler generates seven clock rates from the internal bus clock. The prescaler select bits, PS[2:0], in the TIMA status and control register select the TIMA clock source.

22.4.2 Input Capture

An input capture function has three basic parts: edge select logic, an input capture latch, and a 16-bit counter. Two 8-bit registers, which make up the 16-bit input capture register, are used to latch the value of the free-running counter after the corresponding input capture edge detector senses a defined transition. The polarity of the active edge is programmable. The level transition which triggers the counter transfer is defined by the corresponding input edge bits (ELSxB and ELSxA in TASC0 through TASC5 control registers with x referring to the active channel number). When an active edge occurs on the pin of an input capture channel, the TIMA latches the contents of the TIMA counter into the TIMA channel registers, TACHxH–TACHxL. Input captures can generate TIMA CPU interrupt requests. Software can determine that an input capture event has occurred by enabling input capture interrupts or by polling the status flag bit.

The result obtained by an input capture will be two more than the value of the free-running counter on the rising edge of the internal bus clock preceding the external transition. This delay is required for internal synchronization.

The free-running counter contents are transferred to the TIMA channel status and control register (TACHxH–TACHxL) (see [22.9.5 TIMA Channel Registers](#)) on each proper signal transition regardless of whether the TIMA channel flag (CH0F–CH5F in TASC0–TASC5 registers) is set or clear. When the status flag is set, a CPU interrupt is generated if enabled. The value of the count latched or “captured” is the time of the event. Because this value is stored in the input capture register two bus cycles after the actual event occurs, user software can respond to this event at a later time and determine the actual time of the event. However, this must be done prior to another input capture on the same pin; otherwise, the previous time value will be lost.

By recording the times for successive edges on an incoming signal, software can determine the period and/or pulse width of the signal. To measure a period, two successive edges of the same polarity are captured. To measure a pulse width, two alternate polarity edges are captured. Software should track the overflows at the 16-bit module counter to extend its range.

Another use for the input capture function is to establish a time reference. In this case, an input capture function is used in conjunction with an output compare function. For example, to activate an output signal a specified number of clock cycles after detecting an input event (edge), use the input capture function to record the time at which the edge occurred. A number corresponding to the desired delay is added to this captured value and stored to an output compare register (see [22.9.5 TIMA Channel Registers](#)). Because both input captures and output compares are referenced to the same 16-bit modulo counter, the delay can be controlled to the resolution of the counter independent of software latencies.

Reset does not affect the contents of the input capture channel register (TACHxH–TACHxL).

22.4.3 Output Compare

With the output compare function, the TIMA can generate a periodic pulse with a programmable polarity, duration, and frequency. When the counter reaches the value in the registers of an output compare channel, the TIMA can set, clear, or toggle the channel pin. Output compares can generate TIMA CPU interrupt requests.

22.4.3.1 Unbuffered Output Compare

Any output compare channel can generate unbuffered output compare pulses as described in [22.4.3 Output Compare](#). The pulses are unbuffered because changing the output compare value requires writing the new value over the old value currently in the TIMA channel registers.

An unsynchronized write to the TIMA channel registers to change an output compare value could cause incorrect operation for up to two counter overflow periods. For example, writing a new value before the counter reaches the old value but after the counter reaches the new value prevents any compare during that counter overflow period. Also, using a TIMA overflow interrupt routine to write a new, smaller output compare value may cause the compare to be missed. The TIMA may pass the new value before it is written.

Use these methods to synchronize unbuffered changes in the output compare value on channel x:

- When changing to a smaller value, enable channel x output compare interrupts and write the new value in the output compare interrupt routine. The output compare interrupt occurs at the end of the current output compare pulse. The interrupt routine has until the end of the counter overflow period to write the new value.
- When changing to a larger output compare value, enable channel x TIMA overflow interrupts and write the new value in the TIMA overflow interrupt routine. The TIMA overflow interrupt occurs at the end of the current counter overflow period. Writing a larger value in an output compare interrupt routine (at the end of the current pulse) could cause two output compares to occur in the same counter overflow period.

22.4.3.2 Buffered Output Compare

Channels 0 and 1 can be linked to form a buffered output compare channel whose output appears on the PTE2/TACH0 pin. The TIMA channel registers of the linked pair alternately control the output.

Setting the MS0B bit in TIMA channel 0 status and control register (TASC0) links channel 0 and channel 1. The output compare value in the TIMA channel 0 registers initially controls the output on the PTE2/TACH0 pin. Writing to the TIMA channel 1 registers enables the TIMA channel 1 registers to synchronously control the output after the TIMA overflows. At each subsequent overflow, the TIMA channel registers (0 or 1) that control the output are the ones written to last. TASC0 controls and monitors the buffered output compare function, and TIMA channel 1 status and control register (TASC1) is unused. While the MS0B bit is set, the channel 1 pin, PTE3/TACH1, is available as a general-purpose I/O pin.

Channels 2 and 3 can be linked to form a buffered output compare channel whose output appears on the PTF0/TACH2 pin. The TIMA channel registers of the linked pair alternately control the output.

Setting the MS2B bit in TIMA channel 2 status and control register (TASC2) links channel 2 and channel 3. The output compare value in the TIMA channel 2 registers initially controls the output on the PTF0/TACH2 pin. Writing to the TIMA channel 3 registers enables the TIMA channel 3 registers to synchronously control the output after the TIMA overflows. At each subsequent overflow, the TIMA channel registers (2 or 3) that control the output are the ones written to last. TASC2 controls and monitors the buffered output compare function, and TIMA channel 3 status and control register (TASC3) is unused. While the MS2B bit is set, the channel 3 pin, PTF1/TACH3, is available as a general-purpose I/O pin.

Channels 4 and 5 can be linked to form a buffered output compare channel whose output appears on the PTF2 pin. The TIMA channel registers of the linked pair alternately control the output.

Setting the MS4B bit in TIMA channel 4 status and control register (TSC4) links channel 4 and channel 5. The output compare value in the TIMA channel 4 registers initially controls the output on the PTF2 pin. Writing to the TIMA channel 5 registers enables the TIMA channel 5 registers to synchronously control the output after the TIMA overflows. At each subsequent overflow, the TIMA channel registers (4 or 5) that control the output are the ones written to last. TASC4 controls and monitors the buffered output compare function, and TIMA channel 5 status and control register (TASC5) is unused. While the MS4B bit is set, the channel 5 pin, PTF3, is available as a general-purpose I/O pin.

NOTE: *In buffered output compare operation, do not write new output compare values to the currently active channel registers. Writing to the active channel registers is the same as generating unbuffered output compares.*

22.4.4 Pulse-Width Modulation (PWM)

By using the toggle-on-overflow feature with an output compare channel, the TIMA can generate a PWM signal. The value in the TIMA counter modulo registers determines the period of the PWM signal. The channel pin toggles when the counter reaches the value in the TIMA counter modulo registers. The time between overflows is the period of the PWM signal.

As **Figure 22-3** shows, the output compare value in the TIMA channel registers determines the pulse width of the PWM signal. The time between overflow and output compare is the pulse width. Program the TIMA to clear the channel pin on output compare if the state of the PWM pulse is logic 1. Program the TIMA to set the pin if the state of the PWM pulse is logic 0.

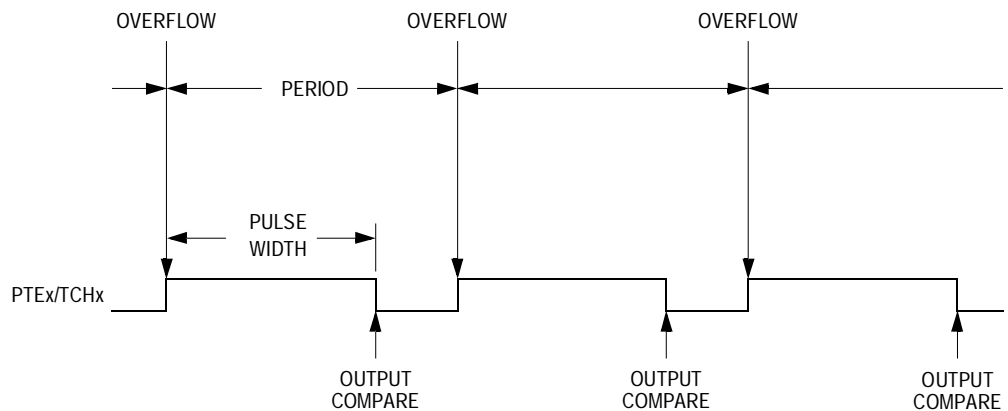

Figure 22-3. PWM Period and Pulse Width

The value in the TIMA counter modulo registers and the selected prescaler output determines the frequency of the PWM output. The frequency of an 8-bit PWM signal is variable in 256 increments. Writing \$00FF (255) to the TIMA counter modulo registers produces a PWM period of 256 times the internal bus clock period if the prescaler select value is \$000 **22.9.1 TIMA Status and Control Register**.

The value in the TIMA channel registers determines the pulse width of the PWM output. The pulse width of an 8-bit PWM signal is variable in 256 increments. Writing \$0080 (128) to the TIMA channel registers produces a duty cycle of 128/256 or 50 percent.

22.4.4.1 Unbuffered PWM Signal Generation

Any output compare channel can generate unbuffered PWM pulses as described in [22.4.4 Pulse-Width Modulation \(PWM\)](#). The pulses are unbuffered because changing the pulse width requires writing the new pulse width value over the value currently in the TIMA channel registers.

An unsynchronized write to the TIMA channel registers to change a pulse width value could cause incorrect operation for up to two PWM periods. For example, writing a new value before the counter reaches the old value but after the counter reaches the new value prevents any compare during that PWM period. Also, using a TIMA overflow interrupt routine to write a new, smaller pulse width value may cause the compare to be missed. The TIMA may pass the new value before it is written to the TIMA channel registers.

Use these methods to synchronize unbuffered changes in the PWM pulse width on channel x:

- When changing to a shorter pulse width, enable channel x output compare interrupts and write the new value in the output compare interrupt routine. The output compare interrupt occurs at the end of the current pulse. The interrupt routine has until the end of the PWM period to write the new value.
- When changing to a longer pulse width, enable channel x TIMA overflow interrupts and write the new value in the TIMA overflow interrupt routine. The TIMA overflow interrupt occurs at the end of the current PWM period. Writing a larger value in an output compare interrupt routine (at the end of the current pulse) could cause two output compares to occur in the same PWM period.

NOTE: *In PWM signal generation, do not program the PWM channel to toggle on output compare. Toggling on output compare prevents reliable 0 percent duty cycle generation and removes the ability of the channel to self-correct in the event of software error or noise. Toggling on output compare also can cause incorrect PWM signal generation when changing the PWM pulse width to a new, much larger value.*

22.4.4.2 Buffered PWM Signal Generation

Channels 0 and 1 can be linked to form a buffered PWM channel whose output appears on the PTE2/TACH0 pin. The TIMA channel registers of the linked pair alternately control the pulse width of the output.

Setting the MS0B bit in TIMA channel 0 status and control register (TASC0) links channel 0 and channel 1. The TIMA channel 0 registers initially control the pulse width on the PTE2/TACH0 pin. Writing to the TIMA channel 1 registers enables the TIMA channel 1 registers to synchronously control the pulse width at the beginning of the next PWM period. At each subsequent overflow, the TIMA channel registers (0 or 1) that control the pulse width are the ones written to last. TASC0 controls and monitors the buffered PWM function, and TIMA channel 1 status and control register (TASC1) is unused. While the MS0B bit is set, the channel 1 pin, PTE3/TACH1, is available as a general-purpose I/O pin.

Channels 2 and 3 can be linked to form a buffered PWM channel whose output appears on the PTF0/TACH2 pin. The TIMA channel registers of the linked pair alternately control the pulse width of the output.

Setting the MS2B bit in TIMA channel 2 status and control register (TASC2) links channel 2 and channel 3. The TIMA channel 2 registers initially control the pulse width on the PTF0/TACH2 pin. Writing to the TIMA channel 3 registers enables the TIMA channel 3 registers to synchronously control the pulse width at the beginning of the next PWM period. At each subsequent overflow, the TIMA channel registers (2 or 3) that control the pulse width are the ones written to last. TASC2 controls and monitors the buffered PWM function, and TIMA channel 3 status and control register (TASC3) is unused. While the MS2B bit is set, the channel 3 pin, PTF1/TACH3, is available as a general-purpose I/O pin.

Channels 4 and 5 can be linked to form a buffered PWM channel whose output appears on the PTF2 pin. The TIMA channel registers of the linked pair alternately control the pulse width of the output.

Setting the MS4B bit in TIMA channel 4 status and control register (TASC4) links channel 4 and channel 5. The TIMA channel 4 registers

initially control the pulse width on the PTF2 pin. Writing to the TIMA channel 5 registers enables the TIMA channel 5 registers to synchronously control the pulse width at the beginning of the next PWM period. At each subsequent overflow, the TIMA channel registers (4 or 5) that control the pulse width are the ones written to last. TASC4 controls and monitors the buffered PWM function, and TIMA channel 5 status and control register (TASC5) is unused. While the MS4B bit is set, the channel 5 pin, PTF3, is available as a general-purpose I/O pin.

NOTE: *In buffered PWM signal generation, do not write new pulse width values to the currently active channel registers. Writing to the active channel registers is the same as generating unbuffered PWM signals.*

22.4.4.3 PWM Initialization

To ensure correct operation when generating unbuffered or buffered PWM signals, use this initialization procedure:

1. In the TIMA status and control register (TASC):
 - a. Stop the TIMA counter by setting the TIMA stop bit, TSTOP.
 - b. Reset the TIMA counter by setting the TIMA reset bit, TRST.
2. In the TIMA counter modulo registers (TAMODH–TAMODL), write the value for the required PWM period.
3. In the TIMA channel x registers (TACHxH–TACHxL), write the value for the required pulse width.
4. In TIMA channel x status and control register (TSCx):
 - a. Write 0:1 (for unbuffered output compare or PWM signals) or 1:0 (for buffered output compare or PWM signals) to the mode select bits, MSxB–MSxA. (See [Table 22-2](#).)
 - b. Write 1 to the toggle-on-overflow bit, TOVx.
 - c. Write 1:0 (to clear output on compare) or 1:1 (to set output on compare) to the edge/level select bits, ELSxB–ELSxA. The output action on compare must force the output to the complement of the pulse width level. (See [Table 22-2](#).)

NOTE: *In PWM signal generation, do not program the PWM channel to toggle on output compare. Toggling on output compare prevents reliable 0 percent duty cycle generation and removes the ability of the channel to self-correct in the event of software error or noise. Toggling on output compare can also cause incorrect PWM signal generation when changing the PWM pulse width to a new, much larger value.*

5. In the TIMA status control register (TASC), clear the TIMA stop bit, TSTOP.

Setting MS0B links channels 0 and 1 and configures them for buffered PWM operation. The TIMA channel 0 registers (TACH0H–TACH0L) initially control the buffered PWM output. TIMA status control register 0 (TASC0) controls and monitors the PWM signal from the linked channels. MS0B takes priority over MS0A.

Setting MS2B links channels 2 and 3 and configures them for buffered PWM operation. The TIMA channel 2 registers (TACH2H–TACH2L) initially control the PWM output. TIMA status control register 2 (TASC2) controls and monitors the PWM signal from the linked channels. MS2B takes priority over MS2A.

Setting MS4B links channels 4 and 5 and configures them for buffered PWM operation. The TIMA channel 4 registers (TACH4H–TACH4L) initially control the PWM output. TIMA status control register 4 (TASC4) controls and monitors the PWM signal from the linked channels. MS4B takes priority over MS4A.

Clearing the toggle-on-overflow bit, TOVx, inhibits output toggles on TIMA overflows. Subsequent output compares try to force the output to a state it is already in and have no effect. The result is a 0 percent duty cycle output.

Setting the channel x maximum duty cycle bit (CHxMAX) and clearing the TOVx bit generates a 100 percent duty cycle output. (See [22.9.4 TIMA Channel Status and Control Registers](#).)

22.5 Interrupts

These TIMA sources can generate interrupt requests:

- TIMA overflow flag (TOF) — The TOF bit is set when the TIMA counter value rolls over to \$0000 after matching the value in the TIMA counter modulo registers. The TIMA overflow interrupt enable bit, TOIE, enables TIMA overflow CPU interrupt requests. TOF and TOIE are in the TIMA status and control register.
- TIMA channel flags (CH5F–CH0F) — The CHxF bit is set when an input capture or output compare occurs on channel x. Channel x TIMA CPU interrupt requests are controlled by the channel x interrupt enable bit, CHxIE.

22.6 Low-Power Modes

The WAIT and STOP instructions put the MCU in low power-consumption standby modes.

22.6.1 Wait Mode

The TIMA remains active after the execution of a WAIT instruction. In wait mode, the TIMA registers are not accessible by the CPU. Any enabled CPU interrupt request from the TIMA can bring the MCU out of wait mode.

If TIMA functions are not required during wait mode, reduce power consumption by stopping the TIMA before executing the WAIT instruction.

22.6.2 Stop Mode

The TIMA is inactive after the execution of a STOP instruction. The STOP instruction does not affect register conditions or the state of the TIMA counter. TIMA operation resumes when the MCU exits stop mode.

22.7 TIMA During Break Interrupts

A break interrupt stops the TIMA counter and inhibits input captures.

The system integration module (SIM) controls whether status bits in other modules can be cleared during the break state. The BCFE bit in the SIM break flag control register (SBFCR) enables software to clear status bits during the break state. (See [9.8.3 SIM Break Flag Control Register](#).)

To allow software to clear status bits during a break interrupt, write a logic 1 to the BCFE bit. If a status bit is cleared during the break state, it remains cleared when the MCU exits the break state.

To protect status bits during the break state, write a logic 0 to the BCFE bit. With BCFE at logic 0 (its default state), software can read and write I/O registers during the break state without affecting status bits. Some status bits have a 2-step read/write clearing procedure. If software does the first step on such a bit before the break, the bit cannot change during the break state as long as BCFE is at logic 0. After the break, doing the second step clears the status bit.

22.8 I/O Signals

Port D shares one of its pins with the TIMA. Port E shares two of its pins with the TIMA and port F shares four of its pins with the TIMA.

PTD6/TACLK is an external clock input to the TIMA prescaler. The six TIMA channel I/O pins are PTE2/TACH0, PTE3/TACH1, PTF0/TACH2, PTF1/TACH3, PTF2, and PTF3.

Timer Interface Module A (TIMA-6)

22.8.1 TIMA Clock Pin (PTD6/ATD14/TCLK)

PTD6/TACLK is an external clock input that can be the clock source for the TIMA counter instead of the prescaled internal bus clock. Select the PTD6/TACLK input by writing logic 1s to the three prescaler select bits, PS[2:0]. (See [22.9.1 TIMA Status and Control Register](#).) The minimum TCLK pulse width, $TCLK_{LMIN}$ or $TCLK_{HMIN}$, is:

$$\frac{1}{\text{bus frequency}} + t_{SU}$$

The maximum TCLK frequency is the least: 4 MHz or bus frequency $\div 2$.

PTD6/TACLK is available as a general-purpose I/O pin or ADC channel when not used as the TIMA clock input. When the PTD6/TACLK pin is the TIMA clock input, it is an input regardless of the state of the DDRD6 bit in data direction register D.

22.8.2 TIMA Channel I/O Pins (PTF3–PTF0/TACH2 and PTE3/TACH1–PTE2/TACH0)

Each channel I/O pin is programmable independently as an input capture pin or an output compare pin. PTE2/TACH0, PTE6/TACH2, and PTF2 can be configured as buffered output compare or buffered PWM pins.

22.9 I/O Registers

These I/O registers control and monitor TIMA operation:

- TIMA status and control register (TASC)
- TIMA control registers (TACNTH–TACNTL)
- TIMA counter modulo registers (TAMODH–TAMODL)
- TIMA channel status and control registers (TASC0, TASC1, TASC2, TASC3, TASC4, and TSAC5)
- TIMA channel registers (TACH0H–TACH0L, TACH1H–TACH1L, TACH2H–TACH2L, TACH3H–TACH3L, TACH4H–TACH4L, and TACH5H–TACH5L)

22.9.1 TIMA Status and Control Register

The TIMA status and control register:

- Enables TIMA overflow interrupts
- Flags TIMA overflows
- Stops the TIMA counter
- Resets the TIMA counter
- Prescales the TIMA counter clock

Address: \$0020

	Bit 7	6	5	4	3	2	1	Bit 0
Read:	TOF	TOIE	TSTOP	0	0	PS2	PS1	PS0
Write:	0			TRST	R			
Reset:	0	0	1	0	0	0	0	0

R = Reserved

Figure 22-4. Timer A Status and Control Register (TASC)

TOF — TIMA Overflow Flag Bit

This read/write flag is set when the TIMA counter resets to \$0000 after reaching the modulo value programmed in the TIMA counter modulo registers. Clear TOF by reading the TIMA status and control register when TOF is set and then writing a logic 0 to TOF. If another TIMA overflow occurs before the clearing sequence is complete, then writing logic 0 to TOF has no effect. Therefore, a TOF interrupt request cannot be lost due to inadvertent clearing of TOF. Reset clears the TOF bit. Writing a logic 1 to TOF has no effect.

- 1 = TIMA counter has reached modulo value.
- 0 = TIMA counter has not reached modulo value.

TOIE — TIMA Overflow Interrupt Enable Bit

This read/write bit enables TIMA overflow interrupts when the TOF bit becomes set. Reset clears the TOIE bit.

- 1 = TIMA overflow interrupts enabled
- 0 = TIMA overflow interrupts disabled

Timer Interface Module A (TIMA-6)

Freescale Semiconductor, Inc.

TSTOP — TIMA Stop Bit

This read/write bit stops the TIMA counter. Counting resumes when TSTOP is cleared. Reset sets the TSTOP bit, stopping the TIMA counter until software clears the TSTOP bit.

- 1 = TIMA counter stopped
- 0 = TIMA counter active

NOTE: Do not set the TSTOP bit before entering wait mode if the TIMA is required to exit wait mode. Also, when the TSTOP bit is set and input capture mode is enabled, input captures are inhibited until TSTOP is cleared.

TRST — TIMA Reset Bit

Setting this write-only bit resets the TIMA counter and the TIMA prescaler. Setting TRST has no effect on any other registers. Counting resumes from \$0000. TRST is cleared automatically after the TIMA counter is reset and always reads as logic 0. Reset clears the TRST bit.

- 1 = Prescaler and TIMA counter cleared
- 0 = No effect

NOTE: Setting the TSTOP and TRST bits simultaneously stops the TIMA counter at a value of \$0000.

PS[2:0] — Prescaler Select Bits

These read/write bits select either the PTD6/TACLK pin or one of the seven prescaler outputs as the input to the TIMA counter as [Table 22-1](#) shows. Reset clears the PS[2:0] bits.

Table 22-1. Prescaler Selection

PS[2:0]	TIMA Clock Source
000	Internal bus clock ÷ 1
001	Internal bus clock ÷ 2
010	Internal bus clock ÷ 4
011	Internal bus clock ÷ 8
100	Internal bus clock ÷ 16
101	Internal bus clock ÷ 32
110	Internal bus clock ÷ 64
111	PTD6/TACLK

22.9.2 TIMA Counter Registers

The two read-only TIMA counter registers contain the high and low bytes of the value in the TIMA counter. Reading the high byte (TACNTH) latches the contents of the low byte (TACNTL) into a buffer. Subsequent reads of TACNTH do not affect the latched TACNTL value until TACNTL is read. Reset clears the TIMA counter registers. Setting the TIMA reset bit (TRST) also clears the TIMA counter registers.

NOTE: *If TACNTH is read during a break interrupt, be sure to unlatch TACNTL by reading TACNTL before exiting the break interrupt. Otherwise, TACNTL retains the value latched during the break.*

Register Name and Address: TCNTH — \$0022

	Bit 7	6	5	4	3	2	1	Bit 0
Read:	Bit 15	14	13	12	11	10	9	Bit 8
Write:	R	R	R	R	R	R	R	R
Reset:	0	0	0	0	0	0	0	0

Register Name and Address: TCNTL — \$0023

	Bit 7	6	5	4	3	2	1	Bit 0
Read:	Bit 7	6	5	4	3	2	1	Bit 0
Write:	R	R	R	R	R	R	R	R
Reset:	0	0	0	0	0	0	0	0

R

 = Reserved

Figure 22-5. TIMA Counter Registers (TCNTH and TCNTL)

Timer Interface Module A (TIMA-6)

22.9.3 TIMA Counter Modulo Registers

The read/write TIMA modulo registers contain the modulo value for the TIMA counter. When the TIMA counter reaches the modulo value, the overflow flag (TOF) becomes set, and the TIMA counter resumes counting from \$0000 at the next clock. Writing to the high byte (TAMODH) inhibits the TOF bit and overflow interrupts until the low byte (TAMODL) is written. Reset sets the TIMA counter modulo registers.

Register Name and Address: TAMODH — \$0024

	Bit 7	6	5	4	3	2	1	Bit 0
Read:	Bit 15	14	13	12	11	10	9	Bit 8
Write:								
Reset:	1	1	1	1	1	1	1	1

Register Name and Address: TAMODL — \$0025

	Bit 7	6	5	4	3	2	1	Bit 0
Read:	Bit 7	6	5	4	3	2	1	Bit 0
Write:								
Reset:	1	1	1	1	1	1	1	1

Figure 22-6. TIMA Counter Modulo Registers (TAMODH and TAMODL)

NOTE: Reset the TIMA counter before writing to the TIMA counter modulo registers.

22.9.4 TIMA Channel Status and Control Registers

Each of the TIMA channel status and control registers:

- Flags input captures and output compares
- Enables input capture and output compare interrupts
- Selects input capture, output compare, or PWM operation
- Selects high, low, or toggling output on output compare
- Selects rising edge, falling edge, or any edge as the active input capture trigger
- Selects output toggling on TIMA overflow
- Selects 100 percent PWM duty cycle
- Selects buffered or unbuffered output compare/PWM operation

Register Name and Address: TASC0 — \$0026

	Bit 7	6	5	4	3	2	1	Bit 0
Read:	CH0F	CH0IE	MS0B	MS0A	ELS0B	ELS0A	TOV0	CH0MAX
Write:	0							
Reset:	0	0	0	0	0	0	0	0

Register Name and Address: TASC1 — \$0029

	Bit 7	6	5	4	3	2	1	Bit 0
Read:	CH1F	CH1IE	0	MS1A	ELS1B	ELS1A	TOV1	CH1MAX
Write:	0		R					
Reset:	0	0	0	0	0	0	0	0

R

 = Reserved

Figure 22-7. TIMA Channel Status and Control Registers (TACC0–TASC5)

Timer Interface Module A (TIMA-6)

Register Name and Address: TASC2 — \$002C

	Bit 7	6	5	4	3	2	1	Bit 0
Read:	CH2F	CH2IE	MS2B	MS2A	ELS2B	ELS2A	TOV2	CH2MAX
Write:	0							
Reset:	0	0	0	0	0	0	0	0

Register Name and Address: TASC3 — \$002F

	Bit 7	6	5	4	3	2	1	Bit 0
Read:	CH3F	CH3IE	0	MS3A	ELS3B	ELS3A	TOV3	CH3MAX
Write:	0		R					
Reset:	0	0	0	0	0	0	0	0

Register Name and Address: TASC4 — \$0032

	Bit 7	6	5	4	3	2	1	Bit 0
Read:	CH4F	CH4IE	MS4B	MS4A	ELS4B	ELS4A	TOV4	CH4MAX
Write:	0							
Reset:	0	0	0	0	0	0	0	0

Register Name and Address: TASC5 — \$0035

	Bit 7	6	5	4	3	2	1	Bit 0
Read:	CH5F	CH5IE	0	MS5A	ELS5B	ELS5A	TOV5	CH5MAX
Write:	0		R					
Reset:	0	0	0	0	0	0	0	0

R = Reserved

Figure 22-7. TIMA Channel Status and Control Registers (TACC0–TASC5) (Continued)

CHxF — Channel x Flag Bit

When channel x is an input capture channel, this read/write bit is set when an active edge occurs on the channel x pin. When channel x is an output compare channel, CHxF is set when the value in the TIMA counter registers matches the value in the TIMA channel x registers.

When CHxIE = 0, clear CHxF by reading TIMA channel x status and control register with CHxF set, and then writing a logic 0 to CHxF. If another interrupt request occurs before the clearing sequence is complete, then writing logic 0 to CHxF has no effect. Therefore, an interrupt request cannot be lost due to inadvertent clearing of CHxF.

Reset clears the CHxF bit. Writing a logic 1 to CHxF has no effect.

1 = Input capture or output compare on channel x

0 = No input capture or output compare on channel x

CHxIE — Channel x Interrupt Enable Bit

This read/write bit enables TIMA CPU interrupts on channel x.

Reset clears the CHxIE bit.

1 = Channel x CPU interrupt requests enabled

0 = Channel x CPU interrupt requests disabled

MSxB — Mode Select Bit B

This read/write bit selects buffered output compare/PWM operation. MSxB exists only in the TIMA channel 0, TIMA channel 2, and TIMA channel 4 status and control registers.

Setting MS0B disables the channel 1 status and control register and reverts TACH1 pin to general-purpose I/O.

Setting MS2B disables the channel 3 status and control register and reverts TACH3 pin to general-purpose I/O.

Setting MS4B disables the channel 5 status and control register and reverts TACH5 pin to general-purpose I/O.

Reset clears the MSxB bit.

1 = Buffered output compare/PWM operation enabled

0 = Buffered output compare/PWM operation disabled

MSxA — Mode Select Bit A

When ELSxB:A \neq 00, this read/write bit selects either input capture operation or unbuffered output compare/PWM operation.

See [Table 22-2](#).

1 = Unbuffered output compare/PWM operation

0 = Input capture operation

When ELSxB:A = 00, this read/write bit selects the initial output level of the TCHx pin once PWM, output compare mode, or input capture mode is enabled. See [Table 22-2](#). Reset clears the MSxA bit.

1 = Initial output level low

0 = Initial output level high

NOTE: *Before changing a channel function by writing to the MSxB or MSxA bit, set the TSTOP and TRST bits in the TIMA status and control register (TSC).*

ELSxB and ELSxA — Edge/Level Select Bits

When channel x is an input capture channel, these read/write bits control the active edge-sensing logic on channel x.

When channel x is an output compare channel, ELSxB and ELSxA control the channel x output behavior when an output compare occurs.

When ELSxB and ELSxA are both clear, channel x is not connected to port E or port F, and pin PTE_x/TACH_x or pin PTF_x/TACH_x is available as a general-purpose I/O pin. However, channel x is at a state determined by these bits and becomes transparent to the respective pin when PWM, input capture mode, or output compare operation mode is enabled. [Table 22-2](#) shows how ELSxB and ELSxA work. Reset clears the ELSxB and ELSxA bits.

Table 22-2. Mode, Edge, and Level Selection

MSxB:MSxA	ELSxB:ELSxA	Mode	Configuration
X0	00	Output preset	Pin under port control; initialize timer output level high
X1	00		Pin under port control; initialize timer output level low
00	01	Input capture	Capture on rising edge only
00	10		Capture on falling edge only
00	11		Capture on rising or falling edge
01	01	Output compare or PWM	Toggle output on compare
01	10		Clear output on compare
01	11		Set output on compare
1X	01	Buffered output compare or buffered PWM	Toggle output on compare
1X	10		Clear output on compare
1X	11		Set output on compare

NOTE: Before enabling a TIMA channel register for input capture operation, make sure that the PTE_x/TACH_x pin or PTF_x/TACH_x pin is stable for at least two bus clocks.

TOV_x — Toggle-On-Overflow Bit

When channel x is an output compare channel, this read/write bit controls the behavior of the channel x output when the TIMA counter overflows. When channel x is an input capture channel, TOV_x has no effect. Reset clears the TOV_x bit.

1 = Channel x pin toggles on TIMA counter overflow.

0 = Channel x pin does not toggle on TIMA counter overflow.

NOTE: When TOV_x is set, a TIMA counter overflow takes precedence over a channel x output compare if both occur at the same time.

CHxMAX — Channel x Maximum Duty Cycle Bit

When the TOVx bit is at logic 0, setting the CHxMAX bit forces the duty cycle of buffered and unbuffered PWM signals to 100 percent. As **Figure 22-8** shows, the CHxMAX bit takes effect in the cycle after it is set or cleared. The output stays at the 100 percent duty cycle level until the cycle after CHxMAX is cleared.

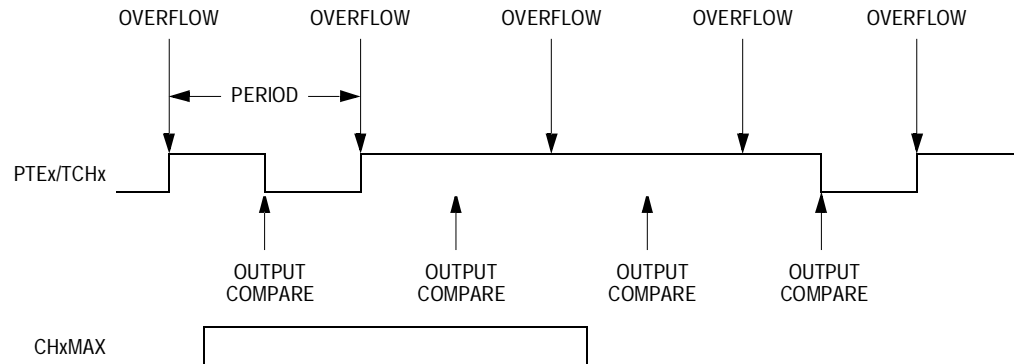

Figure 22-8. CHxMAX Latency

22.9.5 TIMA Channel Registers

These read/write registers contain the captured TIMA counter value of the input capture function or the output compare value of the output compare function. The state of the TIMA channel registers after reset is unknown.

In input capture mode ($MSxB-MSxA = 0:0$), reading the high byte of the TIMA channel x registers (TCHxH) inhibits input captures until the low byte (TCHxL) is read.

In output compare mode ($MSxB-MSxA \neq 0:0$), writing to the high byte of the TIMA channel x registers (TCHxH) inhibits output compares and the CHxF bit until the low byte (TCHxL) is written.

Register Name and Address: TACH0H — \$0027

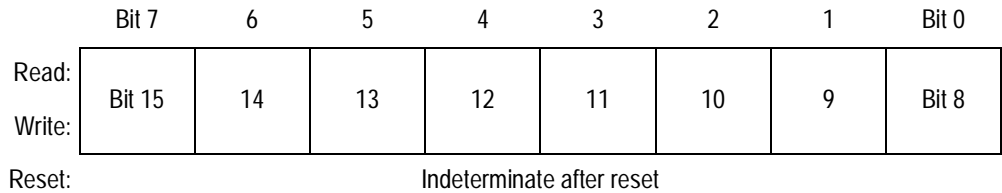

Register Name and Address: TACH0L — \$0028

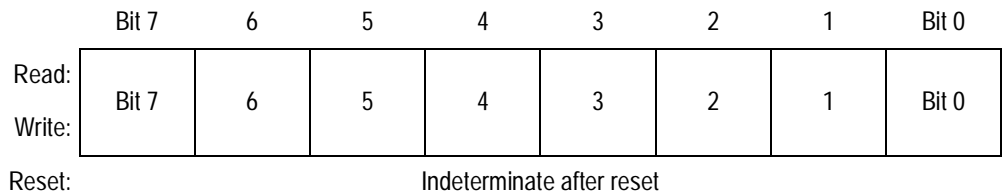

Register Name and Address: TACH1H — \$002A

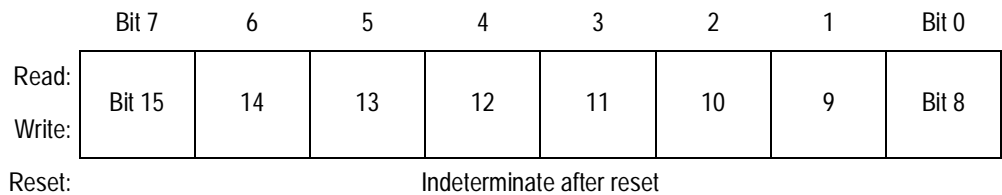

Register Name and Address: TACH1L — \$002B

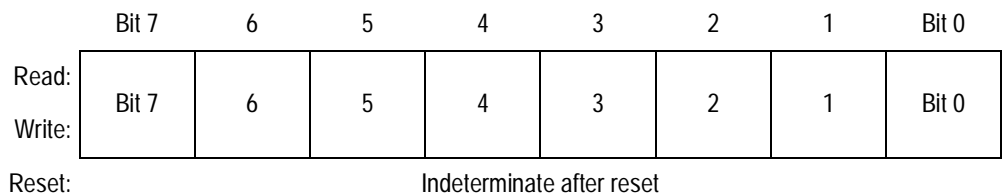

Register Name and Address: TACH2H — \$002D



**Figure 22-9. TIMA Channel Registers
(TACH0H/L–TACH3H/L) (Sheet 1 of 3)**

Timer Interface Module A (TIMA-6)

Register Name and Address: TACH2L — \$002E

	Bit 7	6	5	4	3	2	1	Bit 0
Read:	Bit 7	6	5	4	3	2	1	Bit 0
Write:	Bit 7	6	5	4	3	2	1	Bit 0
Reset:	Indeterminate after reset							

Register Name and Address: TACH3H — \$0030

	Bit 7	6	5	4	3	2	1	Bit 0
Read:	Bit 15	14	13	12	11	10	9	Bit 8
Write:	Bit 15	14	13	12	11	10	9	Bit 8
Reset:	Indeterminate after reset							

Register Name and Address: TACH3L — \$0031

	Bit 7	6	5	4	3	2	1	Bit 0
Read:	Bit 7	6	5	4	3	2	1	Bit 0
Write:	Bit 7	6	5	4	3	2	1	Bit 0
Reset:	Indeterminate after reset							

Register Name and Address: TACH4H — \$0033

	Bit 7	6	5	4	3	2	1	Bit 0
Read:	Bit 15	14	13	12	11	10	9	Bit 8
Write:	Bit 15	14	13	12	11	10	9	Bit 8
Reset:	Indeterminate after reset							

Register Name and Address: TACH4L — \$0034

	Bit 7	6	5	4	3	2	1	Bit 0
Read:	Bit 7	6	5	4	3	2	1	Bit 0
Write:	Bit 7	6	5	4	3	2	1	Bit 0
Reset:	Indeterminate after reset							

Figure 22-9. TIMA Channel Registers (TACH0H/L–TACH3H/L) (Sheet 2 of 3)

Register Name and Address: TACH5H — \$0036

	Bit 7	6	5	4	3	2	1	Bit 0
Read:	Bit 15	14	13	12	11	10	9	Bit 8
Write:								
Reset:	Indeterminate after reset							

Register Name and Address: TACH5L — \$0037

	Bit 7	6	5	4	3	2	1	Bit 0
Read:	Bit 7	6	5	4	3	2	1	Bit 0
Write:								
Reset:	Indeterminate after reset							

**Figure 22-9. TIMA Channel Registers
(TACH0H/L–TACH3H/L) (Sheet 3 of 3)**

Freescale Semiconductor, Inc.

Section 23. Analog-to-Digital Converter (ADC-15)

23.1 Contents

23.2	Introduction	408
23.3	Features	408
23.4	Functional Description	408
23.4.1	ADC Port I/O Pins	409
23.4.2	Voltage Conversion	410
23.4.3	Conversion Time	410
23.4.4	Continuous Conversion	411
23.4.5	Accuracy and Precision	411
23.5	Interrupts	411
23.6	Low-Power Modes	411
23.6.1	Wait Mode	411
23.6.2	Stop Mode	412
23.7	I/O Signals	412
23.7.1	ADC Analog Power Pin (V_{DDAREF})/ADC Voltage Reference Pin (V_{REFH})	412
23.7.2	ADC Analog Ground Pin (V_{SSA})/ADC Voltage Reference Low Pin (V_{REFL})	412
23.7.3	ADC Voltage In (ADCVIN)	412
23.8	I/O Registers	413
23.8.1	ADC Status and Control Register	413
23.8.2	ADC Data Register	416
23.8.3	ADC Input Clock Register	416

23.2 Introduction

This section describes the 8-bit analog-to-digital converter (ADC-15).

23.3 Features

Features of the ADC module include:

- 15 channels with multiplexed input
- Linear successive approximation
- 8-bit resolution
- Single or continuous conversion
- Conversion complete flag or conversion complete interrupt
- Selectable ADC clock

23.4 Functional Description

Fifteen ADC channels are available for sampling external sources at pins PTD6/TACLK–PTD0 and PTB7/ATD7–PTB0/ATD0. An analog multiplexer allows the single ADC converter to select one of 15 ADC channels as ADC voltage in (ADCVIN). ADCVIN is converted by the successive approximation register-based counters. When the conversion is completed, ADC places the result in the ADC data register and sets a flag or generates an interrupt. See [Figure 23-1](#).

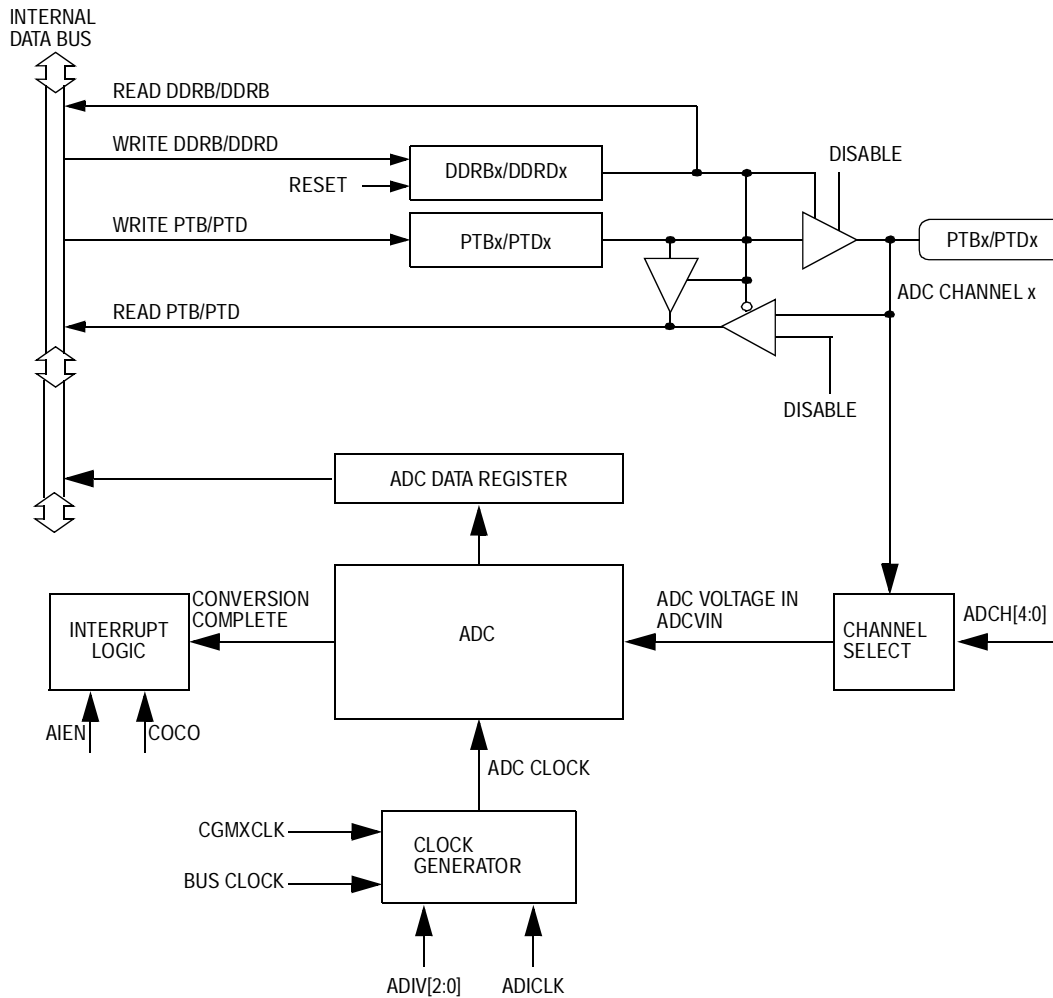

Figure 23-1. ADC Block Diagram

23.4.1 ADC Port I/O Pins

PTD6/TACLK–PTD0 and PTB7/ATD7–PTB0/ATD0 are general-purpose input/output (I/O) pins that share with the ADC channels.

The channel select bits define which ADC channel/port pin will be used as the input signal. The ADC overrides the port I/O logic by forcing that pin as input to the ADC. The remaining ADC channels/port pins are controlled by the port I/O logic and can be used as general-purpose I/O. Writes to the port register or DDR will not have any effect on the port pin

that is selected by the ADC. Read of a port pin which is in use by the ADC will return a logic 0 if the corresponding DDR bit is at logic 0. If the DDR bit is at logic 1, the value in the port data latch is read.

NOTE: Do not use ADC channels ATD14 or ATD12 when using the PTD6/TACLK or PTD4/TBLCK pins as the clock inputs for the 16-bit timers.

23.4.2 Voltage Conversion

When the input voltage to the ADC equals V_{REFH} (see [24.7 ADC Characteristics](#)), the ADC converts the signal to \$FF (full scale). If the input voltage equals V_{SSA} , the ADC converts it to \$00. Input voltages between V_{REFH} and V_{SSA} are a straight-line linear conversion. All other input voltages will result in \$FF if greater than V_{REFH} and \$00 if less than V_{SSA} .

NOTE: Input voltage should not exceed the analog supply voltages.

23.4.3 Conversion Time

Conversion starts after a write to the ADSCR (ADC status control register, \$0038), and requires between 16 and 17 ADC clock cycles to complete. Conversion time in terms of the number of bus cycles is a function of ADICLK select, CGMXCLK frequency, bus frequency, and ADIV prescaler bits. For example, with a CGMXCLK frequency of 4 MHz, bus frequency of 8 MHz, and fixed ADC clock frequency of 1 MHz, one conversion will take between 16 and 17 μ s and there will be between 128 bus cycles between each conversion. Sample rate is approximately 60 kHz.

Refer to [24.7 ADC Characteristics](#).

$$\text{Conversion time} = \frac{16 \text{ to } 17 \text{ ADC clock cycles}}{\text{ADC clock frequency}}$$

$$\text{Number of bus cycles} = \text{Conversion time} \times \text{bus frequency}$$

23.4.4 Continuous Conversion

In the continuous conversion mode, the ADC data register will be filled with new data after each conversion. Data from the previous conversion will be overwritten whether that data has been read or not. Conversions will continue until the ADCO bit (ADC status control register, \$0038) is cleared. The COCO bit is set after the first conversion and will stay set for the next several conversions until the next write of the ADC status and control register or the next read of the ADC data register.

23.4.5 Accuracy and Precision

The conversion process is monotonic and has no missing codes. See [24.7 ADC Characteristics](#) for accuracy information.

23.5 Interrupts

When the AIEN bit is set, the ADC module is capable of generating a CPU interrupt after each ADC conversion. A CPU interrupt is generated if the COCO bit (ADC status control register, \$0038) is at logic 0. If the COCO bit is set, an interrupt is generated. The COCO bit is not used as a conversion complete flag when interrupts are enabled.

23.6 Low-Power Modes

The following subsections describe the low-power modes.

23.6.1 Wait Mode

The ADC continues normal operation during wait mode. Any enabled CPU interrupt request from the ADC can bring the MCU out of wait mode. If the ADC is not required to bring the MCU out of wait mode, power down the ADC by setting the ADCH[4:0] bits in the ADC status and control register before executing the WAIT instruction.

Analog-to-Digital Converter (ADC-15)

23.6.2 Stop Mode

The ADC module is inactive after the execution of a STOP instruction. Any pending conversion is aborted. ADC conversions resume when the MCU exits stop mode. Allow one conversion cycle to stabilize the analog circuitry before attempting a new ADC conversion after exiting stop mode.

23.7 I/O Signals

The ADC module has 15 channels that are shared with I/O ports B and D and one channel with an input-only port bit on port D. Refer to [24.7 ADC Characteristics](#) for voltages referenced in this section.

23.7.1 ADC Analog Power Pin (V_{DDAREF})/ADC Voltage Reference Pin (V_{REFH})

The ADC analog portion uses V_{DDAREF} as its power pin. Connect the V_{DDA}/V_{DDAREF} pin to the same voltage potential as V_{DD} . External filtering may be necessary to ensure clean V_{DDAREF} for good results.

V_{REFH} is the high reference voltage for all analog-to-digital conversions. Connect the V_{REFH} pin to a voltage potential between 1.5 volts and V_{DDAREF}/V_{DDA} depending on the desired upper conversion boundary.

NOTE: Route V_{DDAREF} carefully for maximum noise immunity and place bypass capacitors as close as possible to the package.

23.7.2 ADC Analog Ground Pin (V_{SSA})/ADC Voltage Reference Low Pin (V_{REFL})

The ADC analog portion uses V_{SSA} as its ground pin. Connect the V_{SSA} pin to the same voltage potential as V_{SS} .

V_{REFL} is the lower reference supply for the ADC.

23.7.3 ADC Voltage In (ADCVIN)

ADCVIN is the input voltage signal from one of the 15 ADC channels to the ADC module.

23.8 I/O Registers

These I/O registers control and monitor ADC operation:

- ADC status and control register (ADSCR)
- ADC data register (ADR)
- ADC clock register (ADICLK)

23.8.1 ADC Status and Control Register

The following paragraphs describe the function of the ADC status and control register.

Address: \$0038

	Bit 7	6	5	4	3	2	1	Bit 0
Read:	COCO	AIEN	ADCO	ADCH4	ADCH3	ADCH2	ADCH1	ADCH0
Write:	R							
Reset:	0	0	0	1	1	1	1	1

R = Reserved

Figure 23-2. ADC Status and Control Register (ADSCR)

COCO — Conversions Complete Bit

When the AIEN bit is a logic 0, the COCO is a read-only bit which is set each time a conversion is completed. This bit is cleared whenever the ADC status and control register is written or whenever the ADC data register is read.

If the AIEN bit is a logic 1, the COCO is a read/write bit which selects the CPU to service the ADC interrupt request. Reset clears this bit.

1 = Conversion completed (AIEN = 0)

0 = Conversion not completed (AIEN = 0)

or

CPU interrupt enabled (AIEN = 1)

AIEN — ADC Interrupt Enable Bit

When this bit is set, an interrupt is generated at the end of an ADC conversion. The interrupt signal is cleared when the data register is read or the status/control register is written. Reset clears the AIEN bit.

- 1 = ADC interrupt enabled
- 0 = ADC interrupt disabled

ADCO — ADC Continuous Conversion Bit

When set, the ADC will convert samples continuously and update the ADR register at the end of each conversion. Only one conversion is allowed when this bit is cleared. Reset clears the ADCO bit.

- 1 = Continuous ADC conversion
- 0 = One ADC conversion

ADCH[4:0] — ADC Channel Select Bits

ADCH4, ADCH3, ADCH2, ADCH1, and ADCH0 form a 5-bit field which is used to select one of 15 ADC channels. The six channels are detailed in [Table 23-1](#). Be careful when using a port pin as both an analog and a digital input simultaneously to prevent switching noise from corrupting the analog signal.

The ADC subsystem is turned off when the channel select bits are all set to 1. This feature allows for reduced power consumption for the MCU when the ADC is not used. Reset sets these bits.

NOTE: *Recovery from the disabled state requires one conversion cycle to stabilize.*

Table 23-1. Mux Channel Select

ADCH4	ADCH3	ADCH2	ADCH1	ADCH0	Input Select
0	0	0	0	0	PTB0/ATD0
0	0	0	0	1	PTB1/ATD1
0	0	0	1	0	PTB2/ATD2
0	0	0	1	1	PTB3/ATD3
0	0	1	0	0	PTB4/ATD4
0	0	1	0	1	PTB5/ATD5
0	0	1	1	0	PTB6/ATD6
0	0	1	1	1	PTB7/ATD7
0	1	0	0	0	PTD0
0	1	0	0	1	PTD1
0	1	0	1	0	PTD2
0	1	0	1	1	PTD3
0	1	1	0	0	PTD4/TBLCK
0	1	1	0	1	PTD5
0	1	1	1	0	PTD6/TACLK
Range 01111 (\$0F) to 11010 (\$1A)					Unused (Note 1)
					Unused (Note 1)
1	1	0	1	1	Reserved
1	1	1	0	0	Unused (Note 1)
1	1	1	0	1	V _{REFH} (Note 2)
1	1	1	1	0	V _{SSA} /V _{REFL} (Note 2)
1	1	1	1	1	ADC power off

Notes:

1. If any unused channels are selected, the resulting ADC conversion will be unknown.
2. The voltage levels supplied from internal reference nodes as specified in the table are used to verify the operation of the ADC both in production test and for user applications.

Analog-to-Digital Converter (ADC-15)

23.8.2 ADC Data Register

One 8-bit result register is provided. This register is updated each time an ADC conversion completes.

Address: \$0039

	Bit 7	6	5	4	3	2	1	Bit 0
Read:	AD7	AD6	AD5	AD4	AD3	AD2	AD1	AD0
Write:	R	R	R	R	R	R	R	R
Reset:	Indeterminate after reset							

R

 = Reserved

Figure 23-3. ADC Data Register (ADR)

23.8.3 ADC Input Clock Register

This register selects the clock frequency for the ADC.

Address: \$003A

	Bit 7	6	5	4	3	2	1	Bit 0
Read:	ADIV2	ADIV1	ADIV0	ADICLK	0	0	0	0
Write:	R	R	R	R	R	R	R	R
Reset:	0	0	0	0	0	0	0	0

R

 = Reserved

Figure 23-4. ADC Input Clock Register (ADICLK)

ADIV2–ADIV0 — ADC Clock Prescaler Bits

ADIV2, ADIV1, and ADIV0 form a 3-bit field which selects the divide ratio used by the ADC to generate the internal ADC clock. Table 23-2 shows the available clock configurations. The ADC clock should be set to approximately 1 MHz.

Table 23-2. ADC Clock Divide Ratio

ADIV2	ADIV1	ADIV0	ADC Clock Rate
0	0	0	ADC input clock ÷ 1
0	0	1	ADC input clock ÷ 2
0	1	0	ADC input clock ÷ 4
0	1	1	ADC input clock ÷ 8
1	X	X	ADC input clock ÷ 16

X = Don't care

ADICLK — ADC Input Clock Register Bit

ADICLK selects either bus clock or CGMXCLK as the input clock source to generate the internal ADC clock. Reset selects CGMXCLK as the ADC clock source.

If the external clock (CGMXCLK) is equal to or greater than 1 MHz, CGMXCLK can be used as the clock source for the ADC. If CGMXCLK is less than 1 MHz, use the PLL-generated bus clock as the clock source. As long as the internal ADC clock is at approximately 1 MHz, correct operation can be guaranteed. See [24.7 ADC Characteristics](#).

1 = Internal bus clock

0 = External clock (CGMXCLK)

$$1 \text{ MHz} = \frac{f_{\text{XCLK}} \text{ or bus frequency}}{\text{ADIV}[2:0]}$$

NOTE: *During the conversion process, changing the ADC clock will result in an incorrect conversion.*

Section 24. Electrical Specifications

24.1 Contents

24.2	Maximum Ratings	420
24.3	Functional Operating Range	421
24.4	Thermal Characteristics	421
24.5	5.0 Volt DC Electrical Characteristics	422
24.6	Control Timing	423
24.7	ADC Characteristics	424
24.8	Serial Peripheral Interface (SPI) Timing	425
24.9	CGM Operating Conditions	428
24.10	CGM Component Information	428
24.11	CGM Acquisition/Lock Time Information	429
24.12	Timer Module Characteristics	429
24.13	Memory Characteristics	430
24.14	BDLC Transmitter VPW Symbol Timings	431
24.15	BDLC Receiver VPW Symbol Timings	431

24.2 Maximum Ratings

Maximum ratings are the extreme limits to which the MCU can be exposed without permanently damaging it.

NOTE: *This device is not guaranteed to operate properly at the maximum ratings. Refer to **24.5 5.0 Volt DC Electrical Characteristics** for guaranteed operating conditions.*

Rating	Symbol	Value	Unit
Supply voltage	V_{DD}	-0.3 to +6.0	V
Input voltage	V_{In}	$V_{SS} - 0.3$ to $V_{DD} + 0.3$	V
Maximum current per pin excluding V_{DD} and V_{SS}	I	± 25	mA
Storage temperature	T_{STG}	-55 to +150	°C
Maximum current out of V_{SS}	I_{MVSS}	100	mA
Maximum current into V_{DD}	I_{MVDD}	100	mA
\overline{RST} and \overline{IRQ} input voltage	V_{In}	$V_{DD} + 4$	V

Note: Voltages are referenced to V_{SS} .

NOTE: *This device contains circuitry to protect the inputs against damage due to high static voltages or electric fields; however, it is advised that normal precautions be taken to avoid application of any voltage higher than maximum-rated voltages to this high-impedance circuit. For proper operation, it is recommended that V_{In} and V_{Out} be constrained to the range $V_{SS} \leq (V_{In} \text{ or } V_{Out}) \leq V_{DD}$. Reliability of operation is enhanced if unused inputs are connected to an appropriate logic voltage level (for example, either V_{SS} or V_{DD}).*

24.3 Functional Operating Range

Rating	Symbol	Value	Unit
Operating temperature range	T_A	-40 to 125	°C
Operating voltage range	V_{DD}	$5.0 \pm 10\%$	V

24.4 Thermal Characteristics

Characteristic	Symbol	Value	Unit
Thermal resistance QFP (64 pins)	θ_{JA}	70	°C/W
Thermal resistance PLCC (52 pins)	θ_{JA}	50	°C/W
I/O pin power dissipation	$P_{I/O}$	User determined	W
Power dissipation (Note 1)	P_D	$P_D = (I_{DD} \times V_{DD}) +$ $P_{I/O} = K/(T_J + 273^\circ\text{C})$	W
Constant (Note 2)	K	$P_D \times (T_A + 273^\circ\text{C})$ $+ (P_D^2 \times \theta_{JA})$	W/°C
Average junction temperature	T_J	$T_A = P_D \times \theta_{JA}$	°C

Notes:

1. Power dissipation is a function of temperature.
2. K is a constant unique to the device. K can be determined from a known T_A and measured P_D . With this value of K, P_D , and T_J can be determined for any value of T_A .

Electrical Specifications

24.5 5.0 Volt DC Electrical Characteristics

Characteristic	Symbol	Min	Max	Unit
Output high voltage ($I_{Load} = -2.0$ mA) all ports ($I_{Load} = -5.0$ mA) all ports	V_{OH}	$V_{DD} - 0.8$ $V_{DD} - 1.5$	— —	V
Output low voltage ($I_{Load} = 1.6$ mA) all ports ($I_{Load} = 10.0$ mA) all ports	V_{OL}	— —	0.4 1.5	V
Input high voltage All ports, \overline{IRQ} , RESET, OSC1	V_{IH}	$0.7 \times V_{DD}$	V_{DD}	V
Input low voltage All ports, \overline{IRQ} , RESET, OSC1	V_{IL}	V_{SS}	$0.3 \times V_{DD}$	V
dc injection current, all ports (Note 3)	I_{INJ}	—	± 0.5	mA
V_{DD} supply current	I_{DD}			
Run (Note 4)		—	35	mA
Wait (Note 5)		—	20	mA
Stop (Note 6)		—	50	μ A
25°C with LVI disabled		—	100	μ A
–40°C to +125°C with LVI disabled		—	400	μ A
25°C with LVI enabled	—	500	μ A	
–40°C to +125°C with LVI enabled	—			
I/O ports Hi-Z leakage current	I_L	—	± 1	μ A
Input current	I_{In}	—	± 1	μ A
Capacitance	C_{Out} C_{In}	—	12	μ F
Ports (as input or output)		—	8	
Low-voltage reset inhibit	V_{LVII}	4.0	4.3	V

— Continued —

Notes:

- $V_{DD} = 5.0$ Vdc $\pm 10\%$, $V_{SS} = 0$ Vdc, $T_A = -40^\circ\text{C}$ to $+125^\circ\text{C}$, unless otherwise noted.
- Typical values reflect average measurements at midpoint of voltage range, 25°C only.
- Functionality of the MCU is guaranteed during injection of dc. current up to the maximum specified level. The maximum specified level is the total current for each port and is allowed on a single pin or a combination of pins. Some disturbance of the ADC accuracy is possible during any injection event and is dependant on board layout and power supply decoupling.
- Run (Operating) I_{DD} measured using external square wave clock source ($f_{OP} = 8.4$ MHz). All inputs 0.2 V from rail. No dc loads. Less than 100 pF on all outputs. $C_L = 20$ pF on OSC2. All ports configured as inputs. OSC2 capacitance linearly affects run I_{DD} . Measured with all modules enabled.
- Wait I_{DD} measured using external square wave clock source ($f_{OP} = 8.0$ MHz). All inputs 0.2 Vdc from rail. No dc loads. Less than 100 pF on all outputs, $C_L = 20$ pF on OSC2. All ports configured as inputs. OSC2 capacitance linearly affects wait I_{DD} . Measured with all modules enabled.
- Stop I_{DD} measured with $OSC1 = V_{SS}$.

Characteristic	Symbol	Min	Max	Unit
Low-voltage reset inhibit/recover hysteresis	H_{LVI}	100	300	mV
POR rearm voltage (Note 7)	V_{POR}	0	200	mV
POR reset voltage (Note 8)	V_{PORRST}	0	800	mV
POR rise time ramp rate (Note 9)	R_{POR}	0.02	—	V/ms
High COP disable voltage (Note 10)	V_{HI}	$V_{DD} + 2$	$V_{DD} + 4$	V
High FLASH block protect override (Note 11)	V_{HI}	$V_{DD} + 2$	$V_{DD} + 4$	V

Notes:

- Maximum is highest voltage that POR is guaranteed.
- Maximum is highest voltage that POR is possible.
- If minimum V_{DD} is not reached before the internal POR reset is released, \overline{RST} must be driven low externally until minimum V_{DD} is reached.
- See **14.9 COP Module During Break Interrupts**. V_{HI} on \overline{RST} pin.
- See **Section 4. FLASH-1 Memory** and **Section 5. FLASH-2 Memory** for further information. V_{HI} on \overline{IRQ} pin.

24.6 Control Timing

Characteristic	Symbol	Min	Max	Unit
Bus operating frequency	f_{Bus}	32 k	8.4 M	Hz
\overline{RESET} pulse width low	t_{RL}	1.5	—	t_{cyc}
\overline{IRQ} interrupt pulse width low (edge-triggered)	t_{ILHI}	1.5	—	t_{cyc}
\overline{IRQ} interrupt pulse period	t_{ILIL}	Note 4	—	t_{cyc}
16-bit timer (Note 2) Input capture pulse width (Note 3) Input capture period	t_{TH}, t_{TL} t_{TLTL}	2 Note 4	— —	t_{cyc}

Notes:

- $V_{DD} = 5.0 \text{ Vdc} \pm 10\%$, $V_{SS} = 0 \text{ Vdc}$, $T_A = -40^\circ\text{C}$ to $+125^\circ\text{C}$, unless otherwise noted.
- The 2-bit timer prescaler is the limiting factor in determining timer resolution.
- Refer to **Table 22-2. Mode, Edge, and Level Selection** and supporting note.
- The minimum period t_{TLTL} or t_{ILIL} should not be less than the number of cycles it takes to execute the capture interrupt service routine plus $2 t_{cyc}$.

Electrical Specifications

24.7 ADC Characteristics

Characteristic	Min	Max	Unit	Comments
Resolution	8	8	Bits	
Absolute accuracy ($V_{REFL} = 0\text{ V}$, $V_{DDA}/V_{DDAREF} = V_{REFH} = 5\text{ V} \pm 10\%$)	-1	+1	LSB	Includes quantization
Conversion range (Note 1)	V_{REFL}	V_{REFH}	V	$V_{REFL} = V_{SSA}$
Power-up time	16	17	μs	Conversion time period
Input leakage (Note 3) Ports B and D	—	± 1	μA	
Conversion time	16	17	ADC clock cycles	Includes sampling time
Monotonicity	Inherent within total error			
Zero input reading	00	01	Hex	$V_{In} = V_{REFL}$
Full-scale reading	FE	FF	Hex	$V_{In} = V_{REFH}$
Sample time (Note 2)	5	—	ADC clock cycles	
Input capacitance	—	8	pF	Not tested
ADC internal clock	500 k	1.048 M	Hz	Tested only at 1 MHz
Analog input voltage	V_{REFL}	V_{REFH}	V	

Notes:

- $V_{DD} = 5.0\text{ Vdc} \pm 10\%$, $V_{SS} = 0\text{ Vdc}$, $V_{DDA}/V_{DDAREF} = 5.0\text{ Vdc} \pm 10\%$, $V_{SSA} = 0\text{ Vdc}$, $V_{REFH} = 5.0\text{ Vdc} \pm 10\%$
- Source impedances greater than 10 k Ω adversely affect internal RC charging time during input sampling.
- The external system error caused by input leakage current is approximately equal to the product of R source and input current.

24.8 Serial Peripheral Interface (SPI) Timing

Num	Characteristic	Symbol	Min	Max	Unit
	Operating frequency (Note 3) Master Slave	$f_{BUS(M)}$ $f_{BUS(S)}$	$f_{BUS}/128$ dc	$f_{BUS}/2$ f_{BUS}	MHz
1	Cycle time Master Slave	$t_{cyc(M)}$ $t_{cyc(S)}$	2 1	128 —	t_{cyc}
2	Enable lead time	t_{Lead}	15	—	ns
3	Enable lag time	t_{Lag}	15	—	ns
4	Clock (SCK) high time Master Slave	$t_{W(SCKH)M}$ $t_{W(SCKH)S}$	100 50	— —	ns
5	Clock (SCK) low time Master Slave	$t_{W(SCKL)M}$ $t_{W(SCKL)S}$	100 50	— —	ns
6	Data setup time (inputs) Master Slave	$t_{SU(M)}$ $t_{SU(S)}$	45 5	— —	ns
7	Data hold time (inputs) Master Slave	$t_{H(M)}$ $t_{H(S)}$	0 15	— —	ns
8	Access time, slave (Note 4) CPHA = 0 CPHA = 1	$t_{A(CP0)}$ $t_{A(CP1)}$	0 0	40 20	ns
9	Slave disable time (hold time to high-impedance state)	t_{DIS}	—	25	ns
10	Enable edge lead time to data valid (Note 6) Master Slave	$t_{EV(M)}$ $t_{EV(S)}$	— —	10 40	ns
11	Data hold time (outputs, after enable edge) Master Slave	$t_{HO(M)}$ $t_{HO(S)}$	0 5	— —	ns
12	Data valid Master (before capture edge)	$t_{V(M)}$	90	—	ns
13	Data hold time (outputs) Master (before capture edge)	$t_{HO(M)}$	100	—	ns

Notes:

1. All timing is shown with respect to 30% V_{DD} and 70% V_{DD} , unless otherwise noted; assumes 100 pF load on all SPI pins.
2. Item numbers refer to dimensions in [Figure 24-1](#) and [Figure 24-2](#).
3. f_{BUS} = the currently active bus frequency for the microcontroller.
4. Time to data active from high-impedance state
5. With 100 pF on all SPI pins

Electrical Specifications

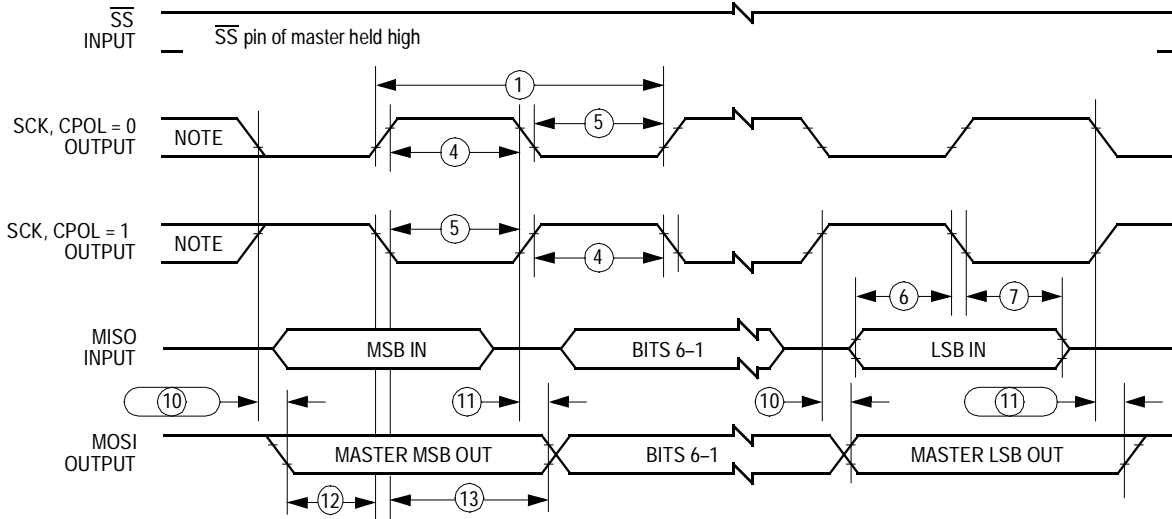

Note: This first clock edge is generated internally, but is not seen at the SCK pin.

a) SPI Master Timing, CPHA = 0

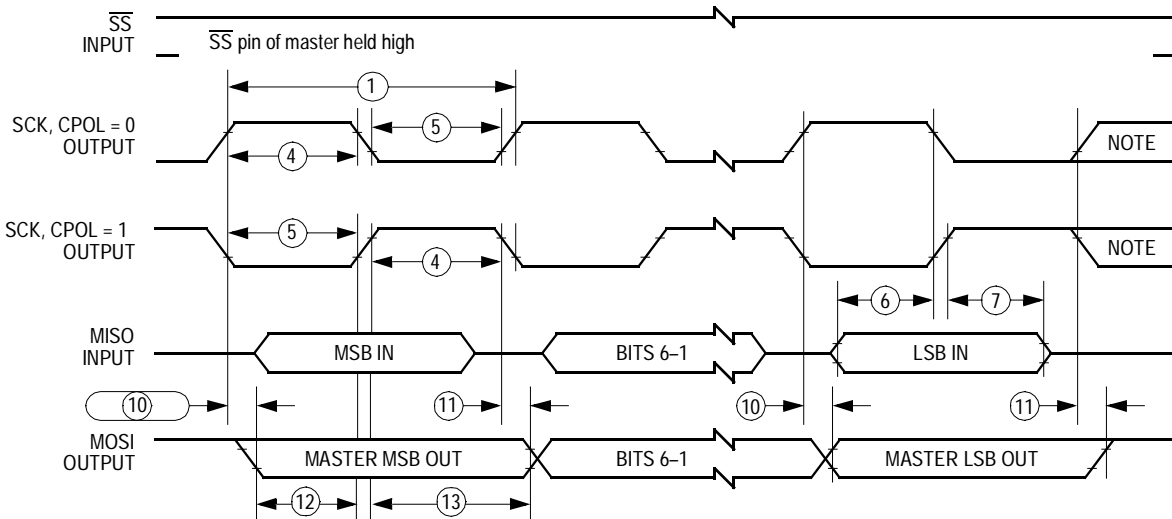

Note: This last clock edge is generated internally, but is not seen at the SCK pin.

b) SPI Master Timing, CPHA = 1

Figure 24-1. SPI Master Timing Diagram

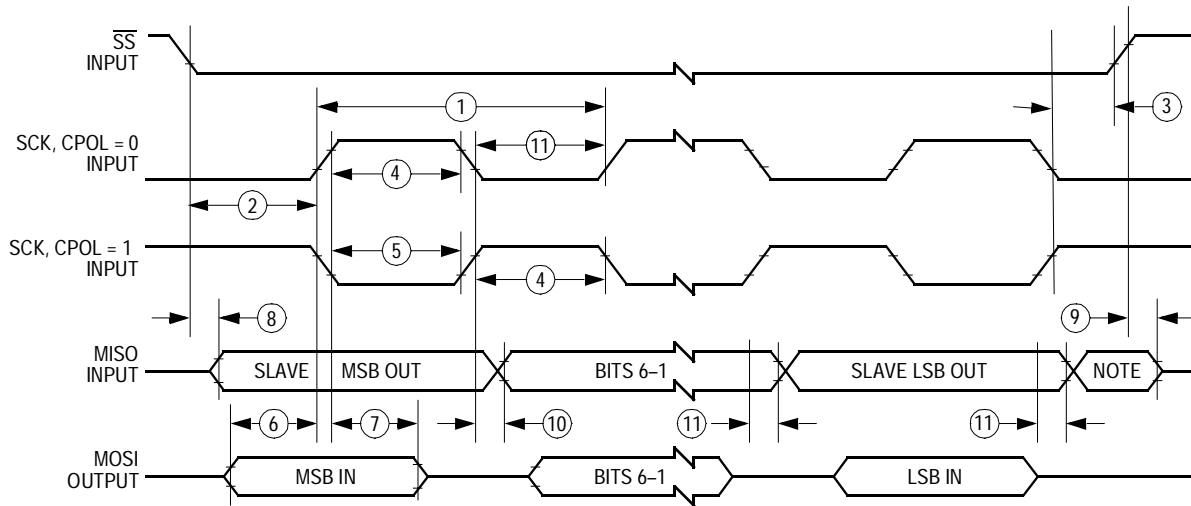

Note: Not defined, but normally MSB of character just received

a) SPI Slave Timing, CPHA = 0

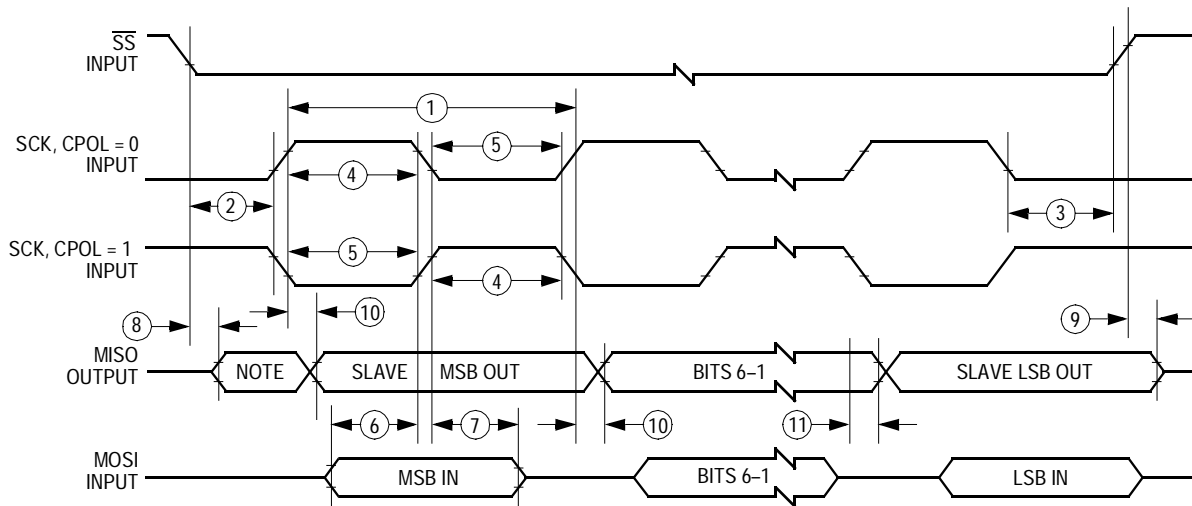

Note: Not defined, but normally LSB of character previously transmitted

b) SPI Slave Timing, CPHA = 1

Figure 24-2. SPI Slave Timing Diagram

Electrical Specifications

24.9 CGM Operating Conditions

Characteristic	Symbol	Min	Typ	Max	Comments
Operating voltage	V_{DD}	4.5 V	—	5.5 V	
Crystal reference frequency	f_{RCLK}	1	4.9152 MHz	16	
Module crystal reference frequency	f_{XCLK}	—	4.9152 MHz	—	Same frequency as f_{RCLK}
Range nominal multiplier (MHz)	f_{NOM}	—	4.9152	—	4.5–5.5 V, V_{DD} only
VCO center-of-range frequency (MHz)	f_{VRS}	4.9152	—	(1)	4.5–5.5 V, V_{DD} only
VCO operating frequency (MHz)	f_{VCLK}	4.9152	—	32.0	

1. f_{VRS} is a nominal value described and mandated as an example in the CGM module section for the desired VCO operating frequency, f_{VCLK} .

24.10 CGM Component Information

Description	Symbol	Min	Typ	Max	Comments
Crystal load capacitance	C_L	—	—	—	Consult crystal manufacturer's data
Crystal fixed capacitance	C1	—	2 x C_L	—	Consult crystal manufacturer's data
Crystal tuning capacitance	C2	—	2 x C_L	—	Consult crystal manufacturer's data
Filter capacitor multiply factor	C_{FACT}	—	0.0154	—	F/s V
Filter capacitor	C_F	—	$C_{FACT} \times (V_{DDA} / f_{XCLK})$	—	See 10.5.3 External Filter Capacitor Pin (CGMXFC) .
Bypass capacitor	C_{BYP}	—	0.1 μF	—	C_{BYP} must provide low AC impedance from $f = f_{XCLK}/100$ to $100 \times f_{VCLK}$, so series resistance must be considered.

24.11 CGM Acquisition/Lock Time Information

Description	Symbol	Min	Typ	Max	Notes
Manual mode time to stable	t_{ACQ}	—	$(8 \times V_{DDA}) / (f_{XCLK} \times K_{ACQ})$	—	If C_F chosen correctly
Manual stable to lock time	t_{AL}	—	$(4 \times V_{DDA}) / (f_{XCLK} \times K_{TRK})$	—	If C_F chosen correctly
Manual acquisition time	t_{Lock}	—	$t_{ACQ} + t_{AL}$	—	
Tracking mode entry frequency tolerance	D_{TRK}	0	—	$\pm 3.6\%$	
Acquisition mode entry frequency tolerance	D_{UNT}	$\pm 6.3\%$	—	$\pm 7.2\%$	
Lock entry frequency tolerance	D_{Lock}	0	—	$\pm 0.9\%$	
Lock exit frequency tolerance	D_{UNL}	$\pm 0.9\%$	—	$\pm 1.8\%$	
Reference cycles per acquisition mode measurement	n_{ACQ}	—	32	—	
Reference cycles per tracking mode measurement	n_{TRK}	—	128	—	
Automatic mode time to stable	t_{ACQ}	n_{ACQ} / f_{XCLK}	$(8 \times V_{DDA}) / (f_{XCLK} \times K_{ACQ})$	—	If C_F chosen correctly
Automatic stable to lock time	t_{AL}	n_{TRK} / f_{XCLK}	$(4 \times V_{DDA}) / (f_{XCLK} \times K_{TRK})$	—	If C_F chosen correctly
Automatic lock time	t_{Lock}	—	$t_{ACQ} + t_{AL}$	—	
PLL jitter, deviation of average bus frequency over 2 ms	—	0	—	$\pm (f_{CRYST}) \times (.025\%) \times (N/4)$	N = VCO frequency multiplier (GBNT)

Notes:

- GBNT guaranteed but not tested
- $V_{DD} = 5.0 \text{ Vdc} \pm 0.5 \text{ V}$, $V_{SS} = 0 \text{ Vdc}$, $T_A = -40^\circ\text{C}$ to $T_{A(MAX)}$, unless otherwise noted.

24.12 Timer Module Characteristics

Characteristic	Symbol	Min	Max	Unit
Input capture pulse width	t_{TIH}, t_{TIL}	125	—	ns
Input clock pulse width	t_{TCH}, t_{TCL}	$(1/f_{OP}) + 5$	—	ns

Electrical Specifications

24.13 Memory Characteristics

Characteristic	Symbol	Min	Max	Unit
RAM data retention voltage	V_{RDR}	0.7	—	V
EEPROM programming time per byte	t_{EEPGM}	10	—	ms
EEPROM erasing time per byte	t_{EEBYTE}	10	—	ms
EEPROM erasing time per block	$t_{EEBLOCK}$	10	—	ms
EEPROM erasing time per bulk	t_{EEBULK}	10	—	ms
EEPROM programming voltage discharge period	t_{EEFPV}	100	—	μ s
EEPROM write/erase cycles	—	10,000	—	Cycles
EEPROM data retention after 10,000 write/erase cycles	—	10	—	Years
FLASH pages per row	—	8	8	Pages
FLASH bytes per page	—	8	8	Bytes
FLASH read bus clock frequency	f_{Read} (Note 1)	32 K	8.4 M	Hz
FLASH charge pump clock frequency (4.5 FLASH Charge Pump Frequency Control)	f_{Pump} (Note 2)	1.8	2.5	MHz
FLASH block/bulk erase time	t_{Erase}	100	110	ms
FLASH high voltage kill time	t_{Kill}	200	—	μ s
FLASH return to read time	t_{HVD}	50	—	μ s
FLASH page program pulses	fls_{Pulses} (Note 3)	—	100	Pulses
FLASH page program step size	t_{Step} (Note 4)	1.0	1.2	ms
FLASH cumulative program operations per row between erase cycles	t_{Row} (Note 5)	—	8	Page program cycles
FLASH HVEN low to MARGIN high time	t_{HVTV}	50	—	μ s
FLASH MARGIN high to PGM low time	t_{VTP}	150	—	μ s
FLASH row erase endurance	—	100	—	Cycles
FLASH row program endurance	—	100	—	Cycles
FLASH data retention time after 100 program/erase cycles	—	10	—	Years

Notes:

- f_{Read} is defined as the frequency range for which the FLASH memory can be read.
- f_{Pump} is defined as the charge pump clock frequency required for program, erase, and margin read operations.
- fls_{Pulses} is defined as the maximum number of t_{Step} pulses required by a page of FLASH memory using the smart programming algorithm.
- t_{Step} is defined as the amount of time during one page program pulse that HVEN is held high.
- t_{Row} is defined as the maximum number of pages programmed on a row before the row using the smart programming algorithm.

24.14 BDLC Transmitter VPW Symbol Timings

Characteristic	Number	Symbol	Min	Typ	Max	Unit
Passive logic 0	10	t_{TVP1}	62	64	66	μs
Passive logic 1	11	t_{TVP2}	126	128	130	μs
Active logic 0	12	t_{TVA1}	126	128	130	μs
Active logic 1	13	t_{TVA2}	62	64	66	μs
Start of frame (SOF)	14	t_{TVA3}	198	200	202	μs
End of data (EOD)	15	t_{TVP3}	198	200	202	μs
End of frame (EOF)	16	t_{TV4}	278	280	282	μs
Inter-frame separator (IFS)	17	t_{TV6}	298	300	302	μs

Notes:

- $f_{BDLC} = 1.048576$ or 1.0 MHz, $V_{DD} = 5.0\text{ V} \pm 10\%$, $V_{SS} = 0\text{ V}$
- The receiver symbol timing boundaries are subject to an uncertainty of 1 t_{BDLC} μs due to sampling considerations.

24.15 BDLC Receiver VPW Symbol Timings

Characteristic	Number	Symbol	Min	Typ	Max	Unit
Passive logic 0	10	t_{TRVP1}	34	64	96	μs
Passive logic 1	11	t_{TRVP2}	96	128	163	μs
Active logic 0	12	t_{TRVA1}	96	128	163	μs
Active logic 1	13	t_{TRVA2}	34	64	96	μs
Start of frame (SOF)	14	t_{TRVA3}	163	200	239	μs
End of data (EOD)	15	t_{TRVP3}	163	200	239	μs
End of frame (EOF)	16	t_{TRV4}	239	280	320	μs
Break	18	t_{TRV6}	240	—	—	μs

Notes:

- $f_{BDLC} = 1.048576$ or 1.0 MHz, $V_{DD} = 5.0\text{ V} \pm 10\%$, $V_{SS} = 0\text{ V}$
- The receiver symbol timing boundaries are subject to an uncertainty of 1 t_{BDLC} μs due to sampling considerations.

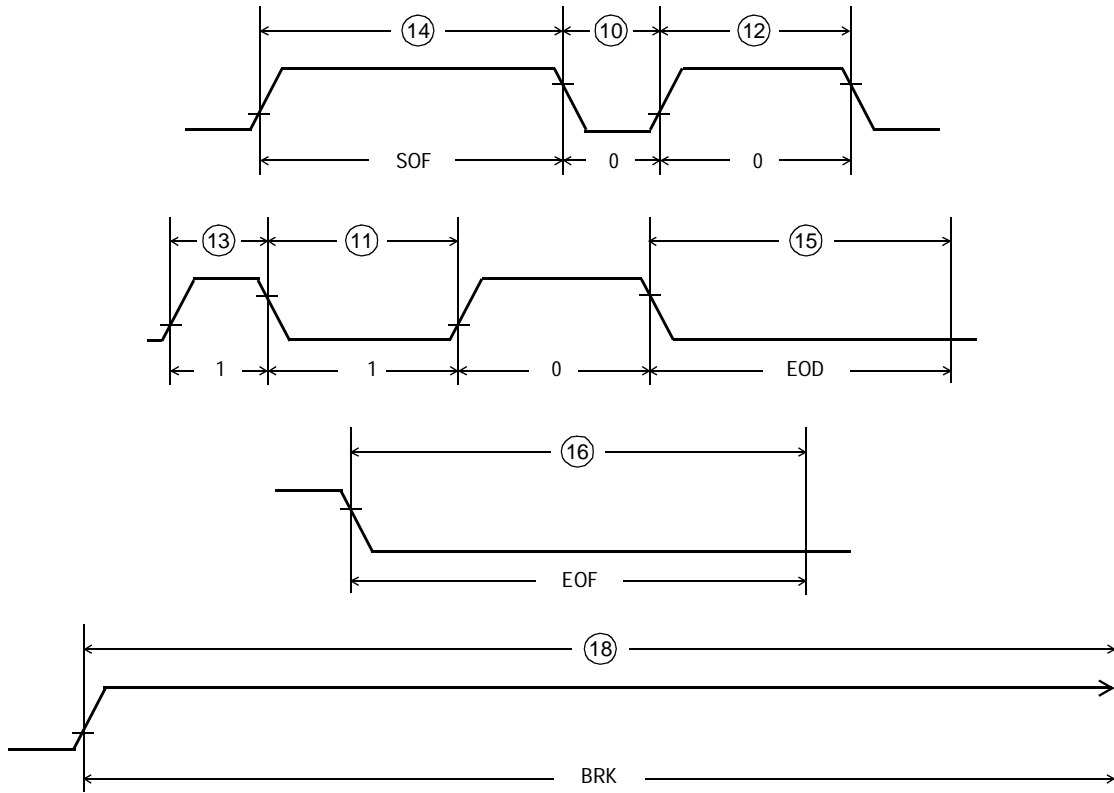

Figure 24-3. BDLC Variable Pulse-Width Modulation (VPW) Symbol Timing

Section 25. Mechanical Specifications

25.1 Contents

25.2	Introduction	433
25.3	52-Pin Plastic Leaded Chip Carrier Package	434
25.4	64-Pin Quad Flat Pack	435

25.2 Introduction

The MC68HC908AS60 is available in two types of packages:

- 56-pin plastic leaded chip carrier (PLCC)
- 64-pin quad flat pack (QFP).

This section shows the latest package specifications available at the time of this publication. To make sure that you have the latest information, contact one of the following:

- Local Motorola Sales Office
- World Wide Web at <http://www.motorola.com/semiconductors/>

Follow the World Wide Web on-line instructions to retrieve the current mechanical specifications.

Mechanical Specifications

25.3 52-Pin Plastic Leaded Chip Carrier Package

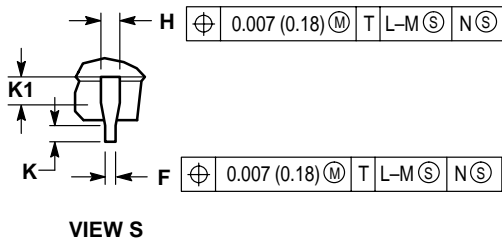
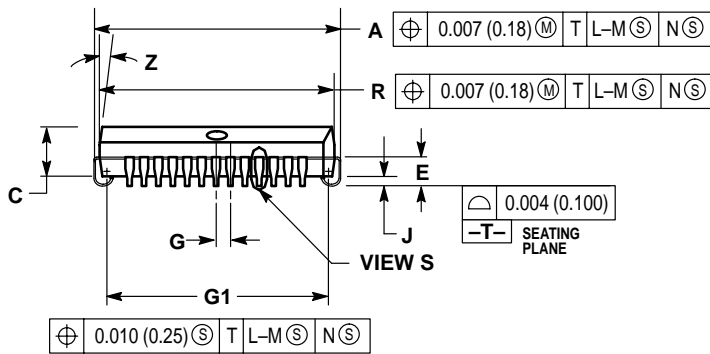
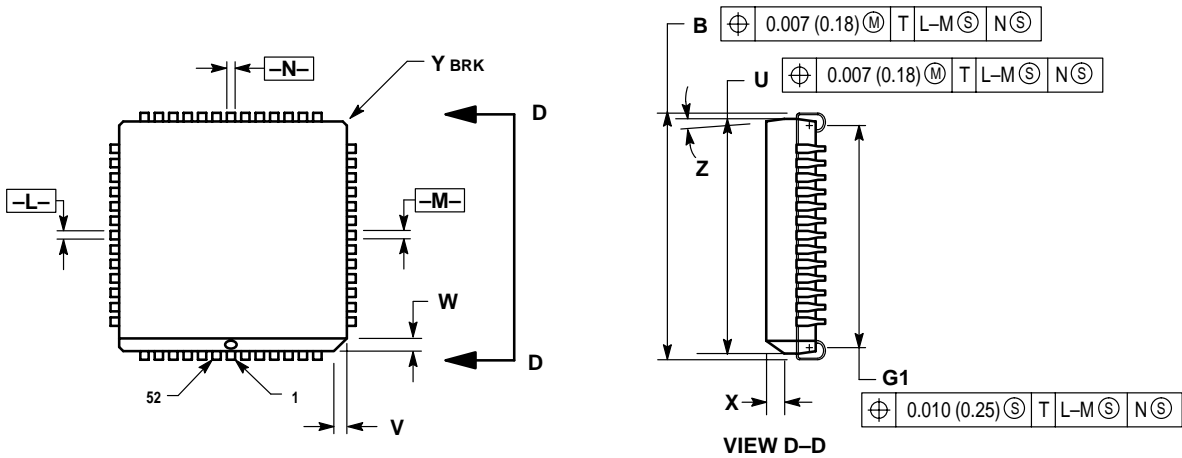

NOTES:

- DATUMS -L-, -M-, AND -N- DETERMINED WHERE TOP OF LEAD SHOULDER EXITS PLASTIC BODY AT MOLD PARTING LINE.
- DIMENSION G1, TRUE POSITION TO BE MEASURED AT DATUM -T-, SEATING PLANE.
- DIMENSIONS R AND U DO NOT INCLUDE MOLD FLASH. ALLOWABLE MOLD FLASH IS 0.010 (0.250) PER SIDE.
- DIMENSIONING AND TOLERANCING PER ANSI Y14.5M, 1982.
- CONTROLLING DIMENSION: INCH.
- THE PACKAGE TOP MAY BE SMALLER THAN THE PACKAGE BOTTOM BY UP TO 0.012 (0.300). DIMENSIONS R AND U ARE DETERMINED AT THE OUTERMOST EXTREMES OF THE PLASTIC BODY EXCLUSIVE OF MOLD FLASH, TIE BAR BURRS, GATE BURRS AND INTERLEAD FLASH, BUT INCLUDING ANY MISMATCH BETWEEN THE TOP AND BOTTOM OF THE PLASTIC BODY.
- DIMENSION H DOES NOT INCLUDE DAMBAR PROTRUSION OR INTRUSION. THE DAMBAR PROTRUSION(S) SHALL NOT CAUSE THE H DIMENSION TO BE GREATER THAN 0.037 (0.940). THE DAMBAR INTRUSION(S) SHALL NOT CAUSE THE H DIMENSION TO BE SMALLER THAN 0.025 (0.635).

DIM	INCHES		MILLIMETERS	
	MIN	MAX	MIN	MAX
A	0.785	0.795	19.94	20.19
B	0.785	0.795	19.94	20.19
C	0.165	0.180	4.20	4.57
E	0.090	0.110	2.29	2.79
F	0.013	0.019	0.33	0.48
G	0.050 BSC		1.27 BSC	
H	0.026	0.032	0.66	0.81
J	0.020	—	0.51	—
K	0.025	—	0.64	—
R	0.750	0.756	19.05	19.20
U	0.750	0.756	19.05	19.20
V	0.042	0.048	1.07	1.21
W	0.042	0.048	1.07	1.21
X	0.042	0.056	1.07	1.42
Y	—	0.020	—	0.50
Z	2°	10°	2°	10°
G1	0.710	0.730	18.04	18.54
K1	0.040	—	1.02	—

25.4 64-Pin Quad Flat Pack

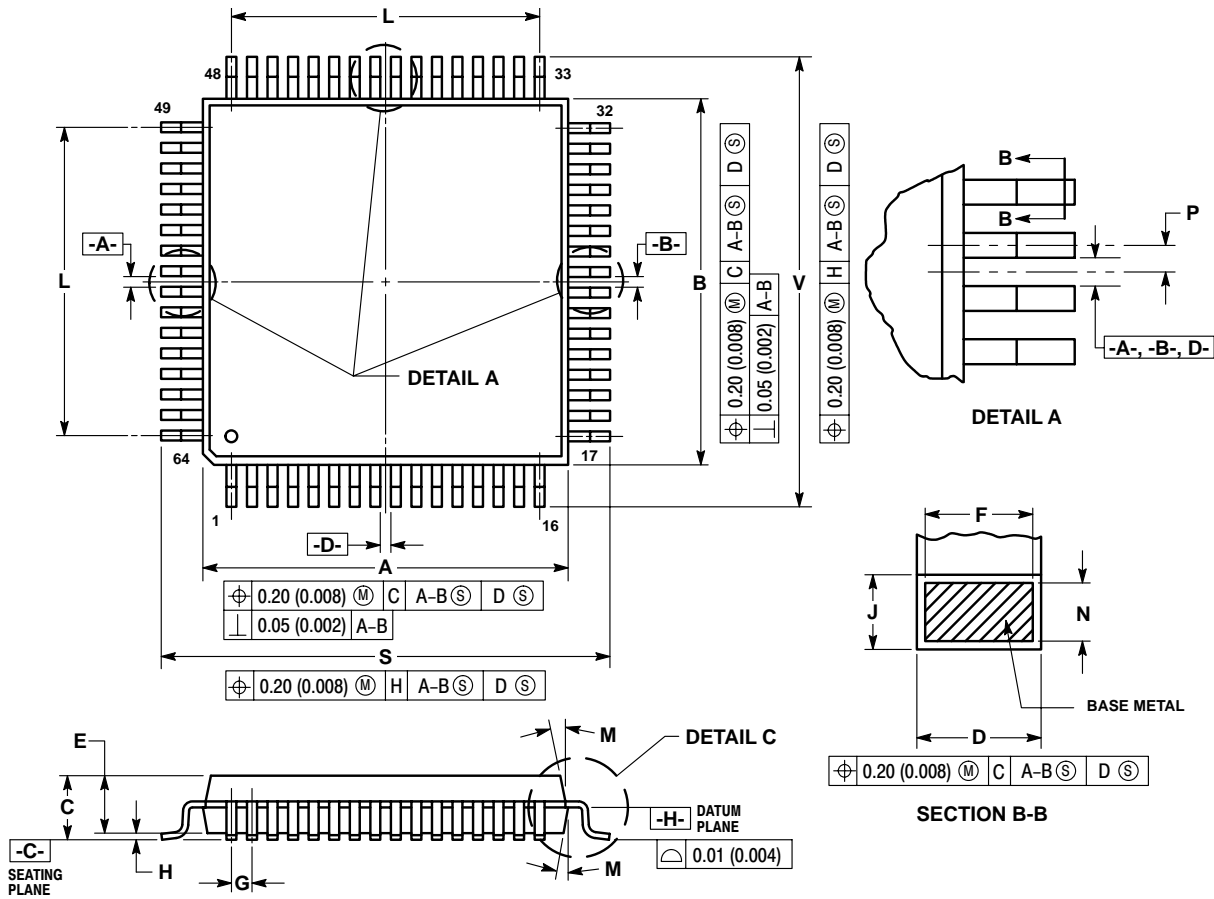

- NOTES:
1. DIMENSIONING AND TOLERANCING PER ANSI Y14.5M, 1982.
 2. CONTROLLING DIMENSION: MILLIMETER.
 3. DATUM PLANE -H- IS LOCATED AT BOTTOM OF LEAD AND IS COINCIDENT WITH THE LEAD WHERE THE LEAD EXITS THE PLASTIC BODY AT THE BOTTOM OF THE PARTING LINE.
 4. DATUMS A-B AND -D- TO BE DETERMINED AT DATUM PLANE -H-.
 5. DIMENSIONS S AND V TO BE DETERMINED AT SEATING PLANE -C-.
 6. DIMENSIONS A AND B DO NOT INCLUDE MOLD PROTRUSION. ALLOWABLE PROTRUSION IS 0.25 (0.010) PER SIDE. DIMENSIONS A AND B DO INCLUDE MOLD MISMATCH AND ARE DETERMINED AT DATUM PLANE -H-.
 7. DIMENSION D DOES NOT INCLUDE DAMBAR PROTRUSION. ALLOWABLE DAMBAR PROTRUSION SHALL BE 0.08 (0.003) TOTAL IN EXCESS OF THE D DIMENSION AT MAXIMUM MATERIAL CONDITION. DAMBAR CANNOT BE LOCATED ON THE LOWER RADIUS OR THE FOOT.

DIM	MILLIMETERS		INCHES	
	MIN	MAX	MIN	MAX
A	13.90	14.10	0.547	0.555
B	13.90	14.10	0.547	0.555
C	2.15	2.45	0.085	0.096
D	0.30	0.45	0.012	0.018
E	2.00	2.40	0.079	0.094
F	0.30	0.40	0.012	0.016
G	0.80 BSC		0.031 BSC	
H	—	0.25	—	0.010
J	0.13	0.23	0.005	0.009
K	0.65	0.95	0.026	0.037
L	12.00 REF		0.472 REF	
M	5°	10°	5°	10°
N	0.13	0.17	0.005	0.007
P	0.40 BSC		0.016 BSC	
Q	0°	7°	0°	7°
R	0.13	0.30	0.005	0.012
S	16.95	17.45	0.667	0.687
T	0.13	—	0.005	—
U	0°	—	0°	—
V	16.95	17.45	0.667	0.687
W	0.35	0.45	0.014	0.018
X	1.6 REF		0.063 REF	

Section 26. Ordering Information

26.1 Contents

26.2	Introduction	437
26.3	MC Order Numbers	437

26.2 Introduction

This section contains instructions for ordering the MC68HC908AS60 (see [Table 26-1](#)).

Packages available are:

- 52-pin plastic leaded chip carrier (PLCC)
- 64-pin quad flat pack (QFP)

26.3 MC Order Numbers

Table 26-1. MC Order Numbers

MC Order Number ⁽¹⁾	Operating Temperature Range
MC68HC908AS60CFN	– 40°C to + 85°C
MC68HC908AS60VFN	– 40°C to + 105°C
MC68HC908AS60MFN	– 40°C to + 125°C
MC68HC908AS60CFU	– 40°C to + 85°C
MC68HC908AS60VFU	– 40°C to + 105°C
MC68HC908AS60MFU	– 40°C to + 125°C

1. FN = Plastic leaded chip carrier (PLCC)
 FU = 4 x 14 mm quad flat pack (QFP)

Index

A

accumulator (A) 116
 ACK1 bit (IRQ1 interrupt request acknowledge bit). 216, 219, 220, 221
 ACQ bit (acquisition mode bit). 161, 162, 171, 172, 177
 arithmetic/logic unit (ALU) 121
 A-to-D converter
 pins. 41
 AUTO bit (automatic bandwidth control bit). 162, 169, 171, 174

B

BCFE bit (break clear flag enable bit) 154, 220, 295, 391
 SCI status bits 241
 BCS bit (base clock select bit). 162, 165, 170, 172, 174, 175
 BDLC
 receive pin 42
 transmit pin. 42
 BIH instruction 219
 BIL instruction 219
 BKF bit (SCI break flag bit) 253
 block protection
 EEPROM-1 94
 EEPROM-2 106
 break character 230
 break interrupt
 causes 186
 effects on COP. 188, 208
 effects on CPU. 122, 187
 effects on SPI. 278
 effects on TIM 187, 295, 391
 break signal 196

BRK module	
break address registers (BRKH/L)	186, 187, 188, 189, 190
break status and control register (BSCR)	186, 189
BRKA bit (break active bit)	186, 189
BRKE bit (break enable bit)	189
bus frequency	114, 163, 168
bus timing	137

C

C bit	
CCR	120
CAN	
receive pin	42
transmit pin	42
CCR	
C bit (carry/borrow flag)	120
H bit (half-carry flag)	119
I bit (interrupt mask)	119
N bit (negative flag)	120
V bit (overflow flag)	119
Z bit (zero flag)	120
ceramic resonator	156
CGM	156
in stop mode	175
in wait mode	175
PLL bandwidth control register (PBWC)	161, 169, 171, 174, 177
PLL control register (PCTL)	165, 169, 174, 175
PLL programming register (PPG)	164, 169, 173
CGMINT signal	168, 175
CGMOUT signal	156, 157, 161, 165, 168, 170, 172, 174, 175, 199, 288
CGMRCLK signal	157, 160
CGMRDV signal	160
CGMVCLK signal	156, 157, 161, 165, 168, 170, 171, 174
CGMVDV signal	160
CGMXCLK signal	138, 156, 157, 165, 168, 170, 175, 204, 205, 206, 208
duty cycle	168
CGMXFC pin	167
CHxF bits (TIM channel interrupt flag bits)	390, 399

CHxIE bits (TIM channel interrupt enable bits)	390, 399
CHxMAX bits (TIM maximum duty cycle bits)	389, 402
CLI instruction	120
clock generator module	
see CGM	
clock generator module (CGM)	199
PLL programming register (PPG)	199
CON1 bit in EENVR1 or EEACR1	99
CON1 bit in EENVR2 or EEACR2	111
CON2 bit in EENVR1 or EEACR1	99
CON2 bit in EENVR2 or EEACR2	111
condition code register (CCR)	119, 217
configuration register (CONFIG)	206, 208
configuration register (CONFIG-1)	182
CONx bits in EENVR1 or EEACR1	99
CONx bits in EENVR2 or EEACR2	111
COP bit (COP reset bit)	204
COP control register (COPCTL)	206, 207
COP counter	203, 204, 206, 207
COP module	208
during break interrupt	208
COP timeout period	204, 208
COPD bit in CONFIG-1	183
COPL bit in CONFIG-1	183
CPHA bit (SPI clock phase bit)	281, 284
CPOL bit (SPI clock polarity bit)	284
CPU interrupt	
software	122, 186, 194
CPU interrupts	
external	294
PLL	161, 162, 168, 169, 174
SCI receiver	239
SPI	275, 278, 286
TIM	399
TIM output compare	382
TIM overflow	294, 390

crosstalk 166
 crystal 156, 157, 168, 178, 199, 204, 205
 CSIC 34

E

EEBCLK bit in EECR1 96
 EEBCLK bit in EECR2 108
 EEBP3–EEBP0 bit in EENVR2 or EEACR2 111
 EEBP3–EEBP0 bits in EENVR1 or EEACR1 99
 EELAT bit in EECR1 97
 EELAT bit in EECR2 109
 EEOFF bit in EECR1 97
 EEOFF bit in EECR2 109
 EEPGM bit in EECR1 98
 EEPGM bit in EECR2 110
 EEPROM array control register (EEACR2) 110
 EEPROM control register (EECR1) 96
 EEPROM control register (EECR2) 108
 EEPROM nonvolatile register (EENVR1) 98
 EEPROM nonvolatile register (EENVR2) 110
 EERA bit in EENVR1 or EEACR1 99
 EERA bit in EENVR2 or EEACR2 111
 EERAS1 and EERAS0 bits in EECR1 97
 EERAS1 and EERAS0 bits in EECR2 109
 ELAT bit (EPROM/OTPROM latch control bit) 66, 79, 80
 electrostatic damage 302
 ELSxA/B bits (TIM edge/level select bits) 388, 400
 ENSCI bit (enable SCI bit) 243
 EPGM bit (EPROM/OTPROM program control bit) 66, 80
 EPROM control register (EPMCR) 65, 79
 EPROM/OTPROM
 programming tools 65, 79
 EPROM/OTPROM security 65, 79
 erase
 EEPROM-1 92
 EEPROM-2 104
 external crystal 172

external filter capacitor 167, 178
 external interrupt pin 40

F

f_{bus} (bus frequency) 164
 FE bit (SCI receiver framing error bit) 253
 FEIE bit (SCI receiver framing error interrupt enable bit) 249
 f_{nom} (nominal center-of-range frequency) 160
 f_{rclk} (PLL reference clock frequency) 160
 f_{rdv} (PLL final reference frequency) 160, 177
 f_{vclk} (VCO output frequency) 160
 f_{vrs} (VCO programmed center-of-range frequency) 160, 164, 174

H

H bit
 CCR 119
 host computer 191, 192, 194

I

I bit
 CCR 119
 I bit (interrupt mask) 217, 221
 I/O port pin termination 302
 I/O registers locations 50
 IDLE bit (SCI receiver idle bit) 251
 idle character 230
 ILAD bit (illegal address reset bit) 153
 ILIE bit (SCI idle line interrupt enable bit) 246
 ILOP bit (illegal opcode reset bit) 153
 ILTY bit (SCI idle line type bit) 244
 IMASK1 bit (IRQ1 interrupt mask bit) 217, 221
 index register (H:X) 116
 input capture 315, 318, 376, 380, 381, 390, 392, 397, 402
 internal address bus 186
 interrupt status and control register (ISCR) 216
 IRQ status and control register (ISCR) 220
 IRQ1 latch 216
 $\overline{IRQ1}$ pin 207

$\overline{\text{IRQ1}}/V_{\text{PP}}$ pin 40, 215, 219
 triggering sensitivity 217
 IRST signal 138, 139

L

L (VCO linear range multiplier) 164, 165
 LOCK bit (lock indicator bit) 161, 169, 171, 174, 177
 LOOPS bit (SCI loop mode select bit) 243
 LVI module 213
 LVI_{TRIPF} and LVI_{TRIPR} 181
 LVI status register (LVISR) 211, 212
 LVI trip voltage. 209
 LVIOUT bit (LVI output bit) 211, 212
 LVIPWR bit (LVI power enable bit) 213
 LVIPWR bit in CONFIG-1 182
 LVIRST bit (LVI reset bit) 210
 LVIRST bit (LVI reset enable bit). 213
 LVIRST bit in CONFIG-1 182
 LVISTOP bit in CONFIG-1. 182

M

M bit (SCI character length bit) 243
 M68HC08 Family 34
 mask option register (MOR) 210, 211
 MODE1 bit (IRQ1 edge/level select bit). 217, 219, 221
 MODF bit (mode fault error bit) 269
 MODF bit (SPI mode fault bit) 287
 monitor commands
 IREAD 198
 READ 197
 READSP 198
 RUN 199
 WRITE 197
 monitor mode. 186, 187, 199, 207
 alternate vector addresses. 194
 baud rate 192, 195, 199
 commands 192
 echoing. 196

monitor ROM 199
 MSxA/B bits (TIM mode select bits) 383, 384, 387, 388,
 389, 399, 400, 402
 MSxB bits (TIM mode select bits) 387

N

N (VCO frequency multiplier) 163, 164, 165
 N bit
 CCR 120
 NEIE bit (SCI receiver noise error interrupt enable bit) 249
 NF bit (SCI noise flag bit) 252
 noise 39, 160, 161, 166, 168, 176, 178, 386, 389

O

OR bit (SCI receiver overrun bit) 251
 ORIE bit (SCI receiver overrun interrupt enable bit) 249
 OSC1 pin 40, 167, 168
 OSC2 pin 40, 167, 168
 oscillator 150, 157, 166, 167, 168, 205
 pins. 40
 output compare 315, 318, 376, 380, 382, 383, 384,
 385, 389, 390, 392, 397, 402
 OVRF bit (overflow bit) 269
 OVRF bit (SPI overflow bit) 286

P

page zero. 117
 PE bit (SCI receiver parity error bit) 253
 PEIE bit (SCI receiver parity error interrupt enable bit) 249
 PEN bit (SCI parity enable bit) 244
 phase-locked loop (PLL) 156, 157, 159, 163, 166, 168,
 174, 175, 176, 177, 178, 199
 acquisition mode 159, 161, 171, 172, 176, 177, 179
 acquisition time 176, 177, 179
 automatic bandwidth mode 161
 lock detector 159, 161, 168
 lock time 176, 177
 loop filter 159, 161, 167

manual bandwidth mode	171
phase detector	159, 177
tracking mode	159, 161, 171, 177
voltage-controlled oscillator (VCO)	157, 159, 161, 165, 171, 173, 174, 178
PIN bit (external reset bit)	139, 153
pins	
assignments	37
ATD7-ATD0	41
ATD8–14	41
BDRxD	41
BDTxD	41, 42
CGMXFC	41
$\overline{\text{IRQ}}$	40
MISO	41
MOSI	41
OSC1	40
OSC2	40
PTA7-PTA0	41
PTB7-PTB0	41
PTC5-PTC0	41
PTD7-PTD0	41
PTE7-PTC0	41
PTF5-PTF0	42
$\overline{\text{RST}}$	40
SPSCK	41
TACH1	41
TACH0	41
TACH2	42
V_{DD} and V_{SS}	39
V_{DDA} pin	40
V_{DDS} pin	40
PLL bit (PLL flag bit)	174
PLL bit (PLL interrupt flag bit)	169
PLLIE bit (PLL interrupt enable bit)	162, 169
PLLON bit (PLL on bit)	162, 170, 173, 175
port A	41, 304–305
data direction register A (DDRA)	304

port B 41, 306–308
 data direction register B (DDRB) 307
 port B data register (PTB) 306
 port C 41, 308–310
 data direction register C (DDRC) 309
 port C data register (PTC) 308
 port D 41, 311–313
 data direction register D (DDRD) 312
 port D data register (PTD) 311
 port E 41, 314–317
 data direction register E (DDRE) 316
 port E data register (PTE) 314
 port F 42, 318–320, 320–322, 323–325
 data direction register F (DDRF) 319
 port F data register (PTF) 318, 320, 323
 power supply 178
 power supply pins 39
 program
 EEPROM-1 90
 EEPROM-2 102
 program counter (PC) 118, 187, 219
 PS[2:0] bits (TIM prescaler select bits) 297, 380, 394
 PSHH instruction 120
 PTY bit (SCI parity bit) 244
 PULH instruction 120
 pulse-width modulation 376
 pulse-width modulation (PWM) 385, 386, 387, 388, 392, 397
 duty cycle 385, 389, 402
 frequency 294, 385
 initialization 388

R

R8 bit (SCI received bit 8) 248
 RAM 61–62, 192
 size 47
 stack RAM 117
 RE bit (SCI receiver enable bit) 247
 redundant mode 94, 106

reset	
COP	203, 207
external	139
external reset pin ($\overline{\text{RST}}$)	40
illegal address	153
illegal opcode	153
internal	139, 206
LVI	137
power-on	140, 206
reset status register (RSR)	204
RPF bit (SCI reception in progress flag bit)	254
$\overline{\text{RST}}$ pin	204
RTI instruction	120, 122, 186
RWU bit (SCI receiver wakeup bit)	247

S

SBK bit (SCI send break bit)	247
SBSW bit (SIM break stop/wait bit)	151
SCI baud rate	
misalignment tolerance	236
selection	255
SCI baud rate register (SCBR)	255
SCI character format	245
SCI control register 1 (SCC1)	242
SCI control register 2 (SCC2)	245
SCI control register 3 (SCC3)	248
SCI data register (SCDR)	254
SCI framing error	236, 253
SCI status register 1 (SCS1)	250
SCI status register 2 (SCS2)	253
SCP1–SCP0 bits (SCI baud rate prescaler bits)	255
SCR2–SCR0 bits (SCI baud rate select bits)	256
SCRF bit (SCI receiver full bit)	251
SCRIE bit (SCI receiver interrupt enable bit)	246
SCTE bit (SCI transmitter empty bit)	250
SCTIE bit (SCI transmitter interrupt enable bit)	246

serial peripheral interface module (SPI)	288
baud rate	285, 288
control register (SPCR)	279, 283, 286
data register (SPDR)	264, 265, 269, 286, 288
I/O pins.	279
in stop mode.	278
mode fault error	269, 287
overflow error	269, 286
slave select pin.	269, 285
status and control register (SPSCR)	264, 269, 275, 285
SIM	
bus frequency.	137
bus timing.	137
clock.	137
SIMOSCEN signal.	157, 168
SPE bit (SPI enable bit).	285
SPMSTR bit (SPI master mode bit).	263, 265, 280, 283
SPR[0:1] bits (SPI baud rate select bits)	264
SPR1[1:0] bits (SPI baud rate select bits)	288
SPRF bit (SPI receiver full bit).	264, 265, 275, 276, 283, 285, 286
SPRIE bit (SPI receiver interrupt enable bit)	275, 283, 286
SPTTE bit (SPI transmitter empty bit)	264, 275, 276, 285, 287
SPTTE bit (SPI transmitter enable bit).	287
SPTIE bit (SPI transmitter interrupt enable bit)	275, 285, 287
SPWOM bit (SPI wired-OR mode bit)	279, 284
SSREC bit in CONFIG-1	183
stack pointer (SP)	117
stack RAM	61, 117
start bit.	196
SCI data.	229
stop bit	
SCI data.	229
STOP bit (STOP enable bit)	208
STOP bit in CONFIG-1	183
STOP instruction	170, 175, 188, 205, 207, 278, 294, 390
stop mode	188, 208, 213, 278, 294, 390
stop mode recovery time	138
SWI instruction	122, 186, 187, 194

system integration module (SIM) 134
 reset status register (SRSR) 153
 SIM counter 138, 142

T

T8 bit (SCI transmitted bit 8) 249
 TC bit (SCI transmission complete bit) 250
 TCIE bit (SCI transmission complete interrupt enable bit) 246
 TE bit (SCI transmitter enable bit) 247
 TIM counter 292, 295, 380, 391
 timer interface module (TIM) 291
 channel registers (TCH0H/L–TCH3H/L) 299, 382, 383, 384, 385,
 386, 387, 391, 392, 401, 402
 channel registers (TCHxH/L) 381
 channel status and control registers (TSC0–TSC3) 383, 387, 397
 clock input pin (PTE3/TCLK) 380, 392
 counter modulo registers (TMODH/L) 294, 299, 390, 396
 counter modulo registers (TMODH:TMODL) 388
 counter registers (TCNTH/L) 298, 395, 399
 counter registers (TCNTH:TCNTL) 298, 395
 DMA select register (TDMA) 394
 modulo registers (TMODH/L) 385
 modulo registers (TMODH:TMODL) 292, 380
 prescaler 380
 status and control register (TSC) 294, 296, 380, 388, 390, 393, 400
 TOF bit (TIM overflow bit) 294, 390
 TOF bit (TIM overflow flag bit) 296, 299, 393, 396
 TOIE bit (TIM overflow interrupt enable bit) 294, 296, 390, 393
 TOVx (TIM toggle on overflow bits) 389
 TOVx bits (TIM overflow bits) 388
 TOVx bits (TIM toggle on overflow bits) 389, 401
 TRST bit (TIM reset bit) 297, 298, 388, 394, 395, 400
 TSTOP bit (TIM stop bit) 297, 388, 394, 400
 TXINV bit (SCI transmit inversion bit) 243

U

user vectors addresses 60

V

V bit

CCR 119

V_{DDA} pin 168, 178, 179

voltage-controlled oscillator (VCO) 163, 168, 170

VRS[7:4] bits (VCO range select bits) 174

W

WAIT instruction 188, 207, 213, 278, 294, 390

wait mode 188, 207, 213, 278, 294, 297, 390, 394

WAKE bit (SCI wakeup condition bit) 244

X

XLD bit (crystal loss detect bit) 172

Z

Z bit

CCR 120

Freescale Semiconductor, Inc.

Freescale Semiconductor, Inc.

**For More Information On This Product,
Go to: www.freescale.com**

Freescale Semiconductor, Inc.



MC68HC08AS60 Technical Data

How to Reach Us:

USA/EUROPE/LOCATIONS NOT LISTED:

Motorola Literature Distribution
P.O. Box 5405
Denver, Colorado 80217
1-303-675-2140
1-800-441-2447

TECHNICAL INFORMATION CENTER:

1-800-521-6274

JAPAN:

Motorola Japan Ltd.
SPS, Technical Information Center
3-20-1, Minami-Azabu, Minato-ku
Tokyo 106-8573 Japan
81-3-3440-3569

ASIA/PACIFIC:

Motorola Semiconductors H.K. Ltd.
Silicon Harbour Centre
2 Dai King Street
Tai Po Industrial Estate
Tai Po, N.T., Hong Kong
852-26668334

HOME PAGE:

<http://www.motorola.com/semiconductors/>



MOTOROLA

MC68HC908AS60/D
REV 1

Q4/00
REV 1