

### Multichannel Optocoupler with Phototransistor Output

#### Description

The CNY74-2 and CNY74-4 consist of a phototransistor optically coupled to a gallium arsenide infrared emitting diode in a 8 lead, resp. 16 lead plastic dual inline packages.

The elements are mounted on one leadframe in coplanar technique, providing a fixed distance between input and output for highest safety requirements.

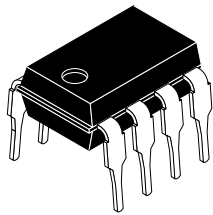

95 10828

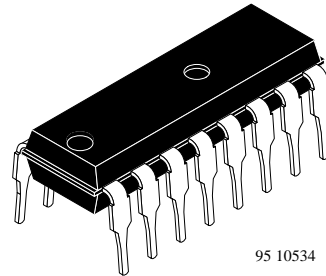

95 10534

#### Applications

Galvanically separated circuits, non-interacting switches.

#### Features

- CNY74-2 includes 2 isolator channels
- CNY74-4 includes 4 isolator channels
- DC isolation test voltage  $V_{IO} = 2.5 \text{ kV}$
- Test class 25/100/21 DIN 40 045
- Low coupling capacitance typical 0.3 pF
- Current Transfer Ratio (CTR) typical 100%
- Low temperature coefficient of CTR
- Wide ambient temperature range

#### Pin Connections

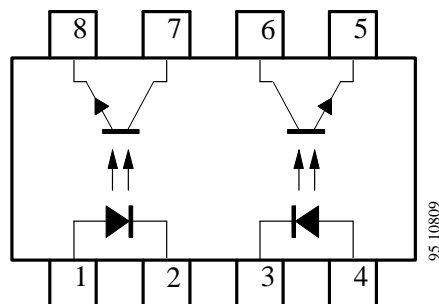

CNY74-2

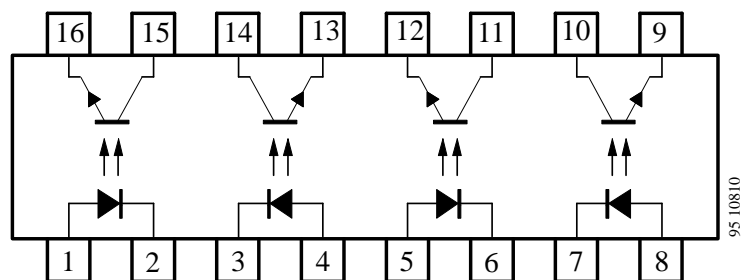

CNY74-4

## Absolute Maximum Ratings

for single coupled system

### Input (Emitter)

Parameters	Test Conditions	Symbol	Value	Unit
Reserve voltage		$V_R$	6	V
Forward current		$I_F$	60	mA
Forward surge current	$t_p \leq 10 \mu s$	$I_{FSM}$	1.5	A
Power dissipation	$T_{amb} \leq 25^\circ C$	$P_V$	100	mW
Junction temperature		$T_j$	125	$^\circ C$

### Output (Detector)

Parameters	Test Conditions	Symbol	Value	Unit
Collector emitter voltage		$V_{CEO}$	70	V
Emitter collector voltage		$V_{ECO}$	7	V
Collector current		$I_C$	50	mA
Peak collector current	$t_p/T = 0.5, t_p \leq 10 ms$	$I_{CM}$	100	mA
Power dissipation	$T_{amb} \leq 25^\circ C$	$P_V$	150	mW
Junction temperature		$T_j$	125	$^\circ C$

### Coupler

Parameters	Test Conditions	Symbol	Value	Unit
DC Isolation test voltage		$V_{IO}^{1)}$	2.5	V
Total power dissipation	$T_{amb} \leq 25^\circ C$	$P_{tot}$	250	mW
Ambient temperature range		$T_{amb}$	-40 to +100	$^\circ C$
Storage temperature range		$T_{stg}$	-55 to +125	$^\circ C$
Soldering temperature	2 mm from case, $t \leq 10 s$	$T_{sd}$	260	$^\circ C$

1) related to standard climate 23/50 DIN 50 014

## Electrical Characteristics

for single coupled system,  $T_{amb} = 25^{\circ}\text{C}$

### Input (Emitter)

Parameters	Test Conditions	Symbol	Min.	Typ.	Max.	Unit
Forward voltage	$I_F = 50 \text{ mA}$	$V_F$		1.25	1.6	V
Breakdown voltage	$I_R = 100 \text{ }\mu\text{A}$	$V_{(BR)}$	5			V

### Output (Detector)

Parameters	Test Conditions	Symbol	Min.	Typ.	Max.	Unit
Collector emitter breakdown voltage	$I_C = 1 \text{ mA}$	$V_{(BR)CEO}$	70			V
Emitter collector breakdown voltage	$I_E = 100 \text{ }\mu\text{A}$	$V_{(BR)ECO}$	7			V
Collector dark current	$V_{CE} = 20 \text{ V}$ , $I_F = 0$ , $E = 0$	$I_{CEO}$			100	nA

### Coupler

Parameters	Test Conditions	Symbol	Min.	Typ.	Max.	Unit
DC Isolation test voltage	$t = 2 \text{ s}$	$V_{IO}^{1)}$	2.5			kV
Isolation resistance	$V_{IO} = 1000 \text{ V}$ , 40% relative humidity	$R_{IO}^{1)}$	$10^{10}$	$10^{12}$		$\Omega$
Collector current	$I_F = 5 \text{ mA}$ , $V_{CE} = 5 \text{ V}$ $I_F = 10 \text{ mA}$ , $V_{CE} = 5 \text{ V}$	$I_C$	2.5	5	30	mA
		$I_C$	6	12		mA
$I_C/I_F$	$I_F = 10 \text{ mA}$ , $V_{CE} = 5 \text{ V}$	CTR	0.5	1	6	
Collector emitter saturation voltage	$I_F = 10 \text{ mA}$ , $I_C = 1 \text{ mA}$	$V_{CEsat}$			0.3	V
Cut-off frequency	$V_{CE} = 5 \text{ V}$ , $I_F = 10 \text{ mA}$ , $R_L = 100 \text{ }\Omega$	$f_c$		100		kHz
Coupling capacitances	$f = 1 \text{ MHz}$	$C_k$		0.3		pF

<sup>1)</sup> related to standard climate 23/50 DIN 50 014

## Switching Characteristics (Typical Values)

$V_S = 5\text{ V}$

Type	$R_L = 100\text{ k}\Omega$ , see figure KEIN MERKER							$R_L = 1\text{ k}\Omega$ , see fig. KEIN MERKER		
	$t_d[\mu\text{s}]$	$t_r[\mu\text{s}]$	$t_{on}[\mu\text{s}]$	$t_s[\mu\text{s}]$	$t_f[\mu\text{s}]$	$t_{off}[\mu\text{s}]$	$I_C[\text{mA}]$	$t_{on}[\mu\text{s}]$	$t_{off}[\mu\text{s}]$	$I_F[\text{mA}]$
CNY74-2/ CNY74-4	3.0	3.0	6.0	0.3	4.7	5.0	2	9	18	10

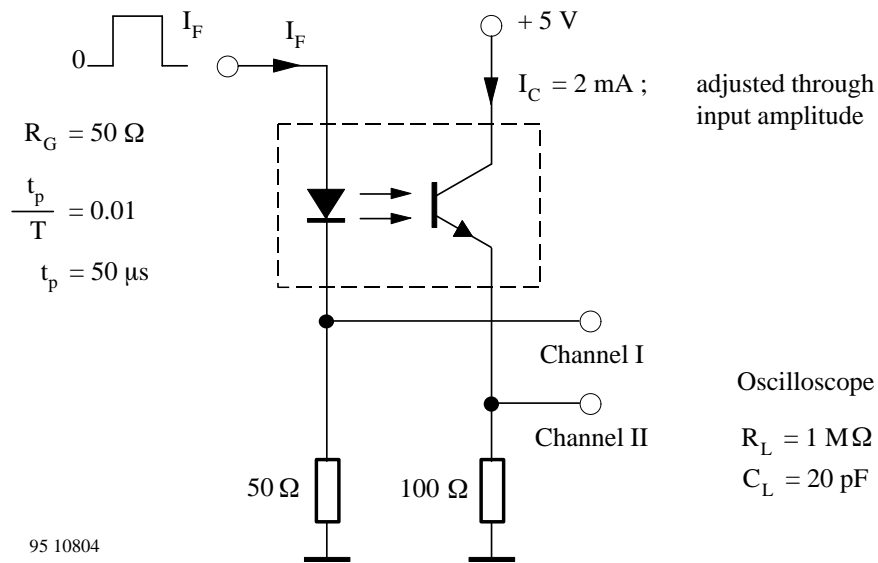

Figure 1. Test circuit, non saturated operation

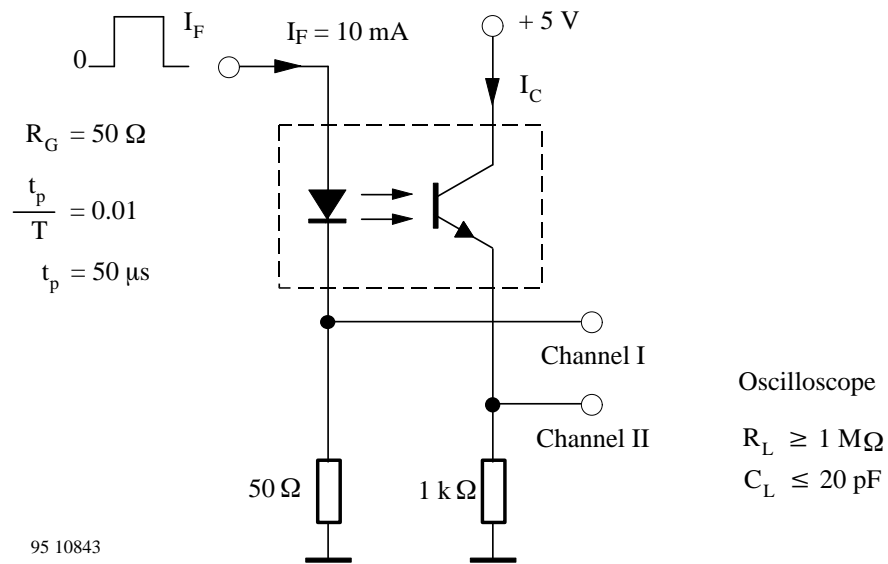

Figure 2. Test circuit, saturated operation

## Ozone Depleting Substances Policy Statement

It is the policy of **TEMIC TELEFUNKEN microelectronic GmbH** to

1. Meet all present and future national and international statutory requirements.
2. Regularly and continuously improve the performance of our products, processes, distribution and operating systems with respect to their impact on the health and safety of our employees and the public, as well as their impact on the environment.

It is particular concern to control or eliminate releases of those substances into the atmosphere which are known as ozone depleting substances (ODSs).

The Montreal Protocol (1987) and its London Amendments (1990) intend to severely restrict the use of ODSs and forbid their use within the next ten years. Various national and international initiatives are pressing for an earlier ban on these substances.

**TEMIC TELEFUNKEN microelectronic GmbH** semiconductor division has been able to use its policy of continuous improvements to eliminate the use of ODSs listed in the following documents.

1. Annex A, B and list of transitional substances of the Montreal Protocol and the London Amendments respectively
2. Class I and II ozone depleting substances in the Clean Air Act Amendments of 1990 by the Environmental Protection Agency (EPA) in the USA
3. Council Decision 88/540/EEC and 91/690/EEC Annex A, B and C (transitional substances) respectively.

**TEMIC** can certify that our semiconductors are not manufactured with ozone depleting substances and do not contain such substances.

**We reserve the right to make changes to improve technical design and may do so without further notice.**

Parameters can vary in different applications. All operating parameters must be validated for each customer application by the customer. Should the buyer use TEMIC products for any unintended or unauthorized application, the buyer shall indemnify TEMIC against all claims, costs, damages, and expenses, arising out of, directly or indirectly, any claim of personal damage, injury or death associated with such unintended or unauthorized use.

TEMIC TELEFUNKEN microelectronic GmbH, P.O.B. 3535, D-74025 Heilbronn, Germany  
Telephone: 49 (0)7131 67 2831, Fax number: 49 (0)7131 67 2423