

# AN5835, AN5836

## DC Volume, Tone Control IC

### Overview

The AN5835 and the AN5836 are the integrated circuits designed for 2-channel volume and tone control circuits.

### Features

- Easier compact set design
- 2-Ch Bass and Treble control available
- Balance control circuit built-in
- DC volume control circuit (AN5836) with linear audibility.
- DC control for all functions

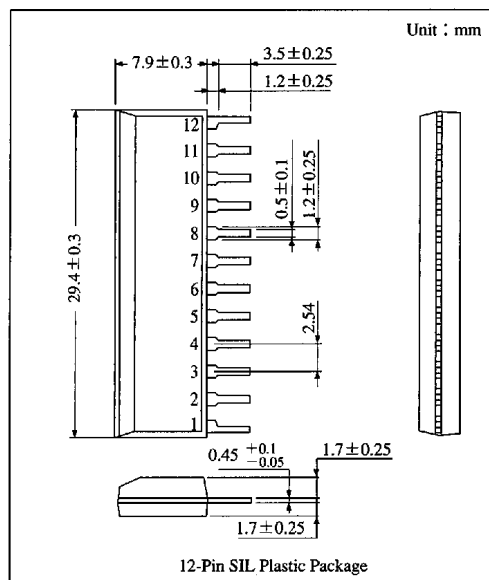

### Pin Descriptions

Pin No.	Pin name
1	Balance control
2	V <sub>cc</sub>
3	R Ch. output
4	R Ch. low freq. input
5	Bass control
6	R Ch. input
7	GND
8	Treble control
9	L Ch. input
10	L Ch. output
11	L Ch. low freq. input
12	Volume control

### Block Diagram

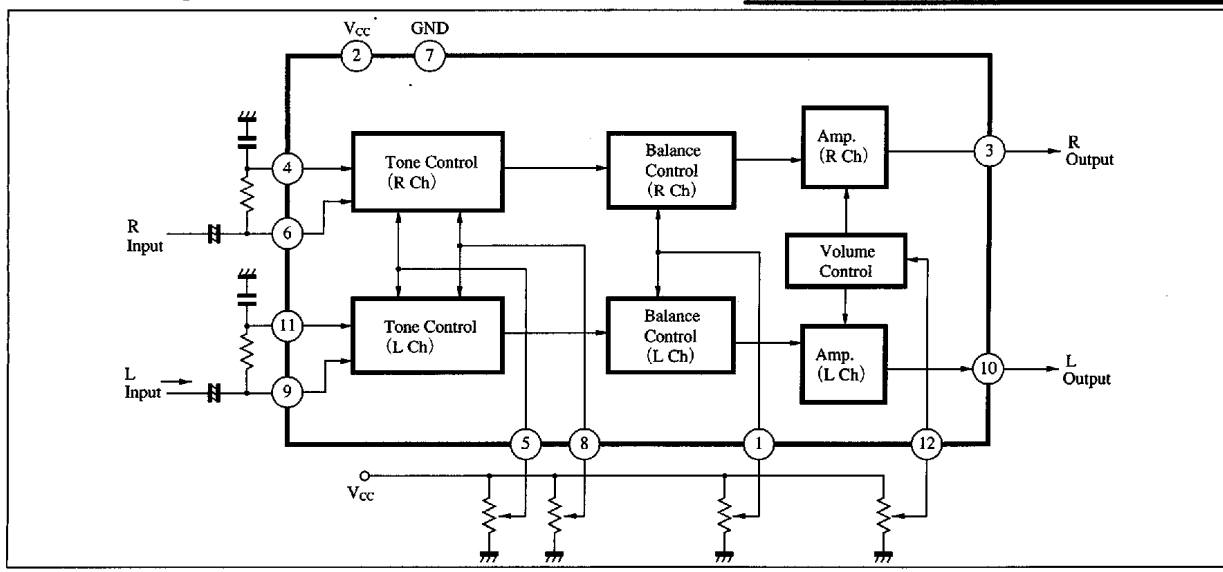

### Absolute Maximum Ratings (Ta=25°C)

Parameter		Symbol	Rating		Unit
Voltage	Supply voltage	V <sub>CC</sub>	14.4		V
	Circuit voltage	V <sub>1,4,5,6-7</sub> V <sub>8,9,11,12-7</sub>	0	V <sub>2-7</sub>	V
Current	Supply current	I <sub>2</sub>	60		mA
	Circuit current	I <sub>3, I10</sub>	-40	—	mA
Power dissipation (Ta=70°C)		P <sub>D</sub>	920		mW
Temperature	Operating ambient temperature	T <sub>opr</sub>	-20 to +70		°C
	Storage temperature	T <sub>stg</sub>	-55 to +150		°C

### Electrical Characteristics (V<sub>CC</sub>=12, Ta=25°C)

Parameter		Symbol	Condition	min	typ	max	Unit	
Circuit current		I <sub>tot</sub>	V <sub>CC</sub> =12V	24	38	50	mA	
Circuit voltage		V <sub>3, 10-7</sub>	V <sub>i</sub> =No signal, V <sub>12</sub> =V <sub>CC</sub> /2, V <sub>1</sub> =V <sub>5</sub> =V <sub>8</sub> =V <sub>CC</sub> /2	8.0	8.4	8.8	V	
Volume circuit	Max. output	V <sub>omax</sub>	f=1kHz, V <sub>i</sub> =400mV <sub>rms</sub>	190	230	270	mV <sub>rms</sub>	
	Channel balance *1	CB	V <sub>12</sub> =V <sub>CC</sub> , V <sub>1</sub> =V <sub>5</sub> =V <sub>8</sub> =V <sub>CC</sub> /2	—	+0.2	±1.0	dB	
	Volume-start voltage *2	V <sub>(st)</sub>	f=1kHz, V <sub>i</sub> =400mV <sub>rms</sub> V <sub>12</sub> =VR, V <sub>1</sub> =V <sub>5</sub> =V <sub>8</sub> =V <sub>CC</sub> /2	AN5835	0.30	0.45	0.70	V
				AN5836	0.40	0.60	0.90	V
Residual-tone level (Volume Min.)	V <sub>min</sub>	f=1kHz, V <sub>i</sub> =400mV <sub>rms</sub> V <sub>12</sub> =0V, V <sub>1</sub> =V <sub>5</sub> =V <sub>8</sub> =V <sub>CC</sub> /2	—	25	50	μV <sub>rms</sub>		
Balance control circuit	Attenuation (R-ch) *3	A <sub>nBR</sub>	f=1kHz, V <sub>i</sub> =400mV <sub>rms</sub> , V <sub>12</sub> =V <sub>CC</sub> , V <sub>5</sub> =V <sub>8</sub> =V <sub>CC</sub> /2, V <sub>OR1</sub> : V <sub>1</sub> =(5.5/12) · V <sub>CC</sub> (VR-1), V <sub>OR2</sub> : V <sub>1</sub> =0V	-32	-45	—	dB	
	Attenuation (L-ch) *4	A <sub>nBL</sub>	f=1kHz, V <sub>i</sub> =400mV <sub>rms</sub> , V <sub>12</sub> =V <sub>CC</sub> , V <sub>5</sub> =V <sub>8</sub> =V <sub>CC</sub> /2, V <sub>OL1</sub> : V <sub>1</sub> =(6.5/12) · V <sub>CC</sub> (VR-1), V <sub>OL2</sub> : V <sub>1</sub> =V <sub>CC</sub>	-32	-45	—	dB	
Tone control circuit	Low freq. boost control characteristics	V <sub>40</sub> /V <sub>1k</sub>	V <sub>1k</sub> : f=1kHz, V <sub>i</sub> =400mV <sub>rms</sub> Output voltage at V <sub>12</sub> =V <sub>CC</sub> , V <sub>1</sub> =V <sub>5</sub> =V <sub>8</sub> =V <sub>CC</sub> /2 V <sub>40</sub> : f=40Hz, V <sub>i</sub> =400mV <sub>rms</sub> Output voltage at V <sub>12</sub> =V <sub>CC</sub> , V <sub>5</sub> =V <sub>8</sub> =V <sub>CC</sub>	8	10	12	dB	
	Low freq. cut control characteristics	V <sub>40</sub> /V <sub>1k</sub>	V <sub>1k</sub> : f=1kHz, V <sub>i</sub> =400mV <sub>rms</sub> Output voltage at V <sub>12</sub> =V <sub>CC</sub> , V <sub>1</sub> =V <sub>5</sub> =V <sub>8</sub> =V <sub>CC</sub> /2 V <sub>40</sub> : f=40Hz, V <sub>i</sub> =400mV <sub>rms</sub> Output voltage at V <sub>12</sub> =V <sub>CC</sub> , V <sub>5</sub> =V <sub>8</sub> =0V	-7.5	-12	-16	dB	
	High freq. boost control characteristics	V <sub>15k</sub> /V <sub>1k</sub>	V <sub>1k</sub> : f=1kHz, V <sub>i</sub> =400mV <sub>rms</sub> Output voltage at V <sub>12</sub> =V <sub>CC</sub> , V <sub>1</sub> =V <sub>5</sub> =V <sub>8</sub> =V <sub>CC</sub> /2 V <sub>15k</sub> : f=15kHz, V <sub>i</sub> =400mV <sub>rms</sub> Output voltage at V <sub>12</sub> =V <sub>CC</sub> , V <sub>5</sub> =V <sub>8</sub> =V <sub>CC</sub>	7.5	10	13	dB	
	High freq. cut control characteristics	V <sub>15k</sub> /V <sub>1k</sub>	V <sub>1k</sub> : f=1kHz, V <sub>i</sub> =400mV <sub>rms</sub> Output voltage at V <sub>12</sub> =V <sub>CC</sub> , V <sub>1</sub> =V <sub>5</sub> =V <sub>8</sub> =V <sub>CC</sub> /2 V <sub>15k</sub> : f=15kHz, V <sub>i</sub> =400mV <sub>rms</sub> Output voltage at V <sub>12</sub> =V <sub>CC</sub> , V <sub>5</sub> =V <sub>8</sub> =0V	-7.5	-12	-18	dB	
Crosstalk	CT	f=1kHz, V <sub>i</sub> =400mV <sub>rms</sub> V <sub>12</sub> =V <sub>CC</sub> , V <sub>1</sub> =V <sub>5</sub> =V <sub>8</sub> =V <sub>CC</sub> /2	-65	-80	—	dB		
Output noise voltage	V <sub>no</sub>	V <sub>i</sub> =No signal, V <sub>12</sub> =V <sub>CC</sub> , V <sub>1</sub> =V <sub>5</sub> =V <sub>8</sub> =V <sub>CC</sub> /2	—	80	120	μV <sub>rms</sub>		
Distortion rate	THD	f=1kHz, V <sub>i</sub> =400mV <sub>rms</sub> V <sub>12</sub> =V <sub>CC</sub> , V <sub>1</sub> =V <sub>5</sub> =V <sub>8</sub> =V <sub>CC</sub> /2	—	0.2	0.5	%		
Input resistance	R <sub>i(6),(9)</sub>	f=1kHz	8.2	11.0	13.5	kΩ		
	R <sub>i(4),(11)</sub>		11.0	16.0	22.0	kΩ		
Output resistance	R <sub>O(3),(10)</sub>	f=1kHz	60	110	160	Ω		

\*1 Deviation between R and L-ch at max. output

\*3, 4 ( A<sub>nBR</sub>: V<sub>OR2</sub>/V<sub>OR1</sub>  
A<sub>nBL</sub>: V<sub>OL2</sub>/V<sub>OL1</sub>)\*2 ( AN5835: V<sub>12</sub> voltage when output voltage is 1mV<sub>rms</sub>  
AN5836: V<sub>12</sub> voltage when output voltage is 0.1mV<sub>rms</sub>)ICs for  
TV

