

32,768-WORD BY 32-BIT SYNCHRONOUS PIPELINED BURST STATIC RAM

DESCRIPTION

The TC55V1325FF is a 1,048,576-bit synchronous pipelined burst static random access memory (SRAM) organized as 32,768 words by 32 bits. It is designed for use as a secondary cache to support microprocessor units equipped with burst functions. A 2-bit burst address counter and control logic is integrated with a 32 K × 32 static RAM. All inputs except output enable \overline{OE} are synchronized to the rising edge of the CLK input. Read operations are initiated with the \overline{ADSP} address status processor input or \overline{ADSC} address status controller input. Subsequent burst addresses can be generated internally under control of the ADV address advance input. Write operations are internally self-timed and are initiated by the rising edge of CLK. Byte write enables (BWI through BW4) allow one to four-byte write operations to be performed. The TC55V1325FF uses a single 3.3 V power supply and is available in a low-profile 100-pin plastic QFP (LQFP).

FEATURES

- Organized as 32 K words by 32 bits.
- Fast cycle time of 13 ns per minimum (76.9 MHz maximum)
- Fast access time of 7 ns maximum (from clock edge to data output)
- Pipelined burst operation
- 2-bit burst address counter (interleaved or linear burst sequences)
- Synchronous self-timed write (global write or byte write)
- LVTTTL compatible interface
- Available in 100-pin LQFP package (LQFP100-P-1420-0.65K : 0.65 mm pitch, 1.6 mm height, typically 0.56 grams)

PIN ASSIGNMENT (TOP VIEW)

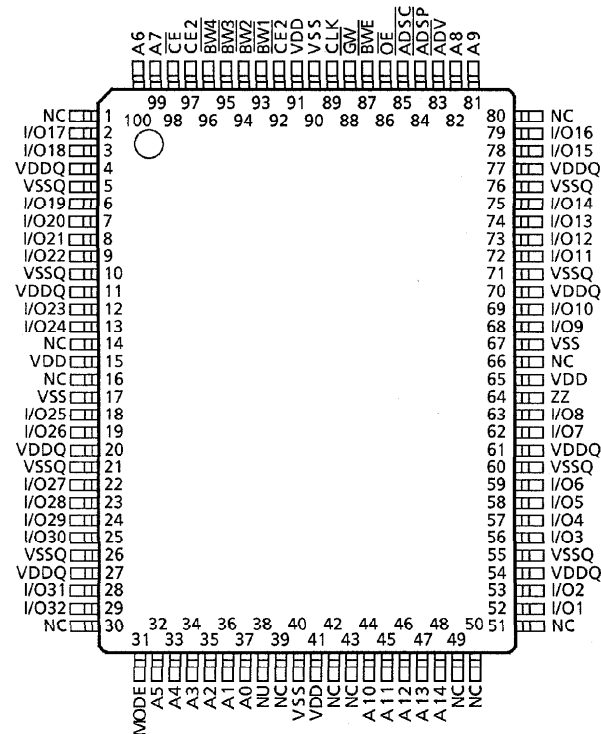

PIN NAMES

| | |
|-------------------|---------------------------------|
| A0 to A14 | Address Inputs |
| I/O1 to I/O32 | Data Inputs/Outputs |
| CLK | Clock Input |
| CE, CE2, CE2 | Chip Enable |
| \overline{ADSP} | Address Status Processor Input |
| \overline{ADSC} | Address Status Controller Input |
| \overline{ADV} | Address Advance Input |
| \overline{GW} | Global Write Enable Input |
| \overline{BWE} | Byte Write Enable Input |
| BW1 to BW4 | Byte Write Enable Inputs |
| \overline{OE} | Output Enable |
| MODE | Mode Select Input |
| ZZ | Snooze Input |
| NU | Not Usable Input |
| V_{DD}, V_{DDQ} | Power Supply |
| V_{SS}, V_{SSQ} | Ground |
| NC | No Connection |

961001EBA1

- TOSHIBA is continually working to improve the quality and the reliability of its products. Nevertheless, semiconductor devices in general can malfunction or fail due to their inherent electrical sensitivity and vulnerability to physical stress. It is the responsibility of the buyer, when utilizing TOSHIBA products, to observe standards of safety, and to avoid situations in which a malfunction or failure of a TOSHIBA product could cause loss of human life, bodily injury or damage to property. In developing your designs, please ensure that TOSHIBA products are used within specified operating ranges as set forth in the most recent products specifications. Also, please keep in mind the precautions and conditions set forth in the TOSHIBA Semiconductor Reliability Handbook.
- The products described in this document are subject to foreign exchange and foreign trade control laws.
- The information contained herein is presented only as a guide for the applications of our products. No responsibility is assumed by TOSHIBA CORPORATION for any infringements of intellectual property or other rights of the third parties which may result from its use. No license is granted by implication or otherwise under any intellectual property or other rights of TOSHIBA CORPORATION or others.
- The information contained herein is subject to change without notice.

BLOCK DIAGRAM

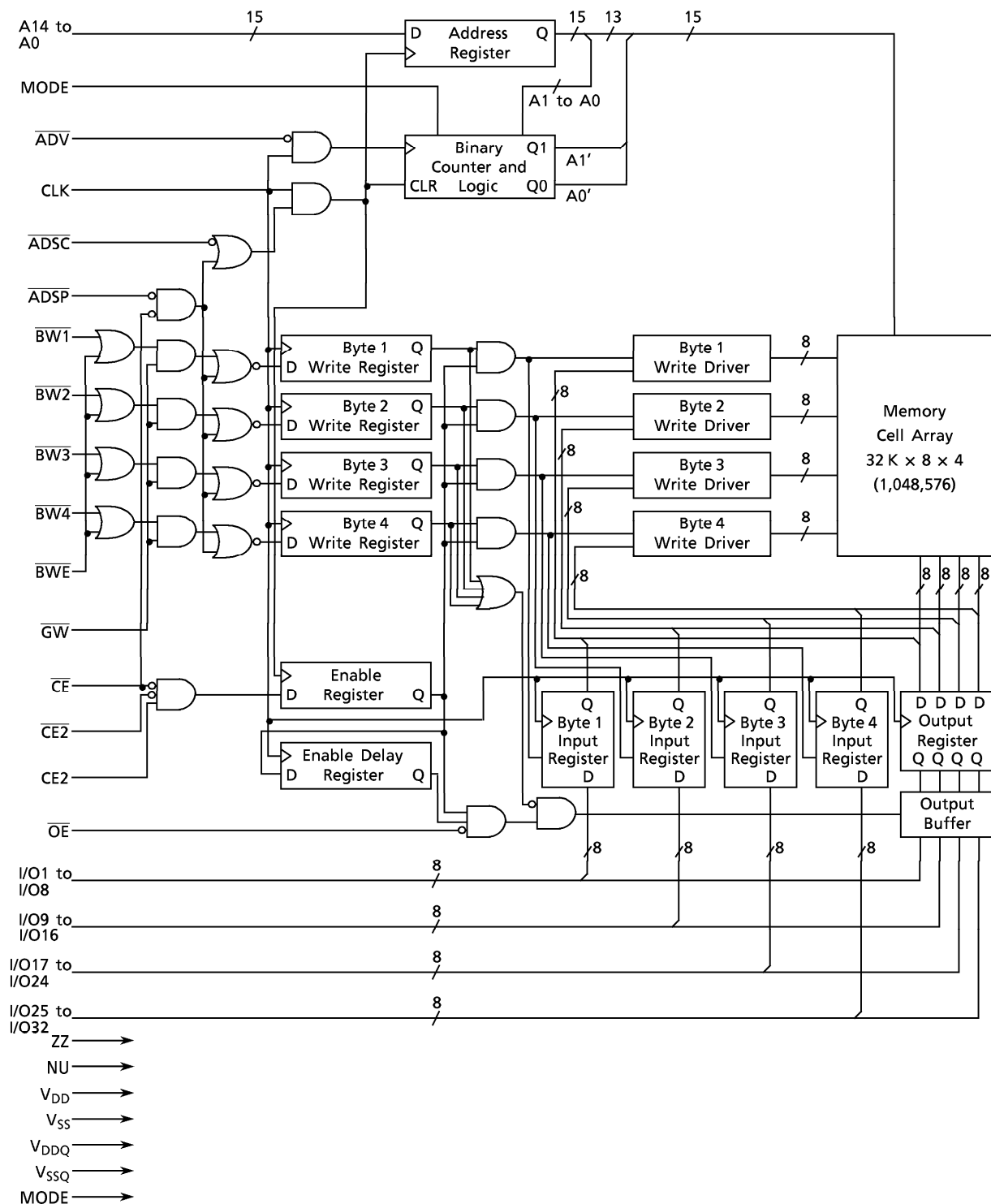

PIN DESCRIPTIONS

| PIN NUMBER | SYMBOL | TYPE | DESCRIPTION |
|---|---|------------------------|---|
| 37, 36, 35, 34, 33, 32, 100, 99, 82, 81, 44, 45, 46, 47, 48 | A0 to A14 | Input (synchronous) | Synchronous Address Inputs Registered on the rising edge of CLK. Address inputs must meet the specified setup and hold times with respect to the CLK rising edge when the chip is enabled. |
| 93, 94, 95, 96 | $\overline{BW1}$, $\overline{BW2}$, $\overline{BW3}$, $\overline{BW4}$ | Input (synchronous) | Synchronous Byte Write Enables These active low inputs control byte write operations when \overline{BWE} is low. $\overline{BW1}$ controls I/O1 through I/O8. $\overline{BW2}$ controls I/O9 through I/O16. $\overline{BW3}$ controls I/O17 through I/O24. $\overline{BW4}$ controls I/O25 through I/O32. For byte write operations, when any of these four inputs go Low, all outputs go to high impedance. |
| 87 | \overline{BWE} | Input (synchronous) | Synchronous Byte Write Enable This active low input controls byte write operations. |
| 88 | \overline{GW} | Input (synchronous) | Synchronous Global Write This active low input controls 32-bit write operations independent of the \overline{BWE} and $\overline{BW1}$ to $\overline{BW4}$ inputs. |
| 89 | CLK | Input | Reference Clock All synchronous input signals are registered on the rising edge of CLK. Synchronous signal timings are measured from the rising edge of CLK. Synchronous input signals must meet the specified setup and hold times with respect to the rising edge of CLK. |
| 83 | \overline{ADV} | Input (synchronous) | Synchronous Burst Advance This active low signal controls the internal burst address counter after an external address has been loaded. When Low, the internal burst address is advanced. When High, the internal burst address is not advanced. If a write operation initiated by \overline{ADSP} is desired, this signal must be High to write the loaded address on the rising edge of the first clock after the assertion of \overline{ADSP} . |
| 84 | \overline{ADSP} | Input (synchronous) | Synchronous Address Status Processor This active low signal controls the burst start by registering a new external address. The write enables (\overline{GW} , \overline{BWE} , $\overline{BW1}$ to $\overline{BW4}$) are ignored at the assertion of \overline{ADSP} and a read operation is initiated. Subsequent operations are dependent on the write enables at the rising edge of the first clock after the assertion of \overline{ADSP} . This signal is ignored if \overline{CE} is High. |

| PIN NUMBER | SYMBOL | TYPE | DESCRIPTION |
|--|-------------------|-------------------------------|---|
| 85 | $\overline{AD5C}$ | Input (synchronous) | Synchronous Address Status Controller This active low signal initiates a burst read or write, depending on the write enables (\overline{GW} , \overline{BWE} , $BW1$ to $BW4$), by registering a new external address. |
| 98 | \overline{CE} | Input (synchronous) | Synchronous Chip Enable This active low signal controls the chip status (enable or disable) and the internal use of \overline{ADSP} . It is sampled only when a new external address is loaded. |
| 92 | $\overline{CE2}$ | Input (synchronous) | Synchronous Chip Enable This active low signal controls the chip status (enable or disable). It is sampled only when a new external address is loaded. It can be used for memory expansion. |
| 97 | CE2 | Input (synchronous) | Synchronous Chip Enable This active high signal controls the chip status (enable or disable). It is sampled only when a new external address is loaded. It can be used for memory expansion. |
| 86 | \overline{OE} | Input (asynchronous) | Asynchronous Output Enable This active low signal controls all 32-bit I/O output buffers. It must be high while write data is being driven prior to the assertion of the byte write enables (\overline{GW} , \overline{BWE} , $BW1$ to $BW4$) following a read operation. |
| 52, 53, 56, 57, 58, 59, 62, 63, 68, 69, 72, 73, 74, 75, 78, 79, 2, 3, 6, 7, 8, 9, 12, 13, 18, 19, 22, 23, 24, 25, 28, 29 | I/O1 to I/O32 | Input/Output (synchronous) | Synchronous Data Inputs/Outputs Byte1 is I/O1 to I/O8, Byte2 is I/O9 to I/O16, Byte3 is I/O17 to I/O24, Byte4 is I/O25 to I/O32. |
| 31 | MODE | Input (asynchronous) | Mode Select This signal selects the burst sequence. If High or not connected, the burst sequence defaults to Interleaved Burst. If Low, the burst sequence is Linear Burst. This input is pulled up internally. Do not alter the input state while the device is operating. |

| PIN NUMBER | SYMBOL | TYPE | DESCRIPTION |
|--|-----------|-------------------------|--|
| 64 | ZZ | Input (asynchronous) | Snooze This active high signal is used to place the device into sleep mode (low power standby mode). When Low or not connected, the device remains in the active state. When high, the device goes into a sleep state, and memory data is retained. After this signal is deasserted, the device wakes up when a read or write operation is initiated by \overline{ADSP} or \overline{ADSC} . If ZZ (sleep) mode will not be used, connect this input to V_{SS} . |
| 38 | NU | Input (asynchronous) | Not Used This signal is reserved by the manufacturer. It must be tied low or left unconnected. This input is internally pulled down. |
| 1, 14, 16, 30, 39, 42, 43, 49, 50, 51, 66, 80 | NC | — | No Connection These inputs are not connected internally. Pin numbers 49 and 50 are reserved for future device expansion. |
| 15, 41, 65, 91 | V_{DD} | Supply | Power Supply |
| 17, 40, 67, 90 | V_{SS} | Ground | Ground |
| 4, 11, 20, 27, 54, 61, 70, 77 | V_{DDQ} | Supply | Output Buffer Power Supply |
| 5, 10, 21, 26, 55, 60, 71, 76 | V_{SSQ} | Ground | Output Buffer Ground |

OPERATING MODE

(1) Synchronous Input Truth Table

| OPERATION | CLK | \overline{CE} | $\overline{CE2}$ | CE2 | \overline{ADSP} | \overline{ADSC} | \overline{ADV} | \overline{WRITE} ⁴ | ZZ ¹ | ADDRESS USED | I/O ⁵ | CURRENT ² |
|----------------------|-----|-----------------|------------------|-----|-------------------|-------------------|------------------|---------------------------------|-----------------|-----------------------|------------------|----------------------|
| Begin Burst Read | L→H | L | L | H | L | x | x | x | L | External Address | Dout (n) | I _{DDO1} |
| | L→H | L | L | H | H | L | x | H | L | | | |
| Continue Burst Read | L→H | x | x | x | H | H | L | H | L | Next Burst Address | Dout (n) | I _{DDO1} |
| | L→H | H | x | x | L ⁶ | H | L | H | L | | | |
| Suspend Burst Read | L→H | x | x | x | H | H | H | H | L | Current Burst Address | Dout (n) | I _{DDO2} |
| | L→H | H | x | x | L ⁶ | H | H | H | L | | | |
| Begin Burst Write | L→H | L | L | H | H | L | x | L | L | External Address | Din (p) | N/A |
| | L→H | x | x | x | H | H | H | L | L | Current Burst Address | | |
| | L→H | H | x | x | L ⁶ | H | H | L | L | Current Burst Address | | |
| Continue Burst Write | L→H | x | x | x | H | H | L | L | L | Next Burst Address | Din (p) | N/A |
| | L→H | H | x | x | L ⁶ | H | L | L | L | | | |
| Suspend Burst Write | L→H | x | x | x | H | H | H | L | L | Current Burst Address | Din (p) | N/A |
| | L→H | H | x | x | L ⁶ | H | H | L | L | | | |
| Deselected | L→H | H | x | x | x | L | x | x | L | None | Hi-Z (p) | I _{DD52} |
| | L→H | L | H | x | L | x | x | x | L | | | |
| | L→H | L | x | L | L | x | x | x | L | | | |
| | L→H | L | H | x | H | L | x | x | L | | | |
| | L→H | L | x | L | H | L | x | x | L | | | |
| Snooze | L→H | x | x | x | x | x | x | x | H | None | Hi-Z (p) | I _{DD53} |

- Note: 1. ZZ input, although asynchronous, is included in this table.
 2. Consumption current does not include output buffer current.
 3. H means logical High and L means logical Low. x means Don't Care.
 4. $\overline{WRITE} = L$ means any one or more of the byte write enable inputs ($\overline{BW1}$, $\overline{BW2}$, $\overline{BW3}$, $\overline{BW4}$) and \overline{BWE} are Low, or that \overline{GW} is Low. $\overline{WRITE} = H$ means \overline{GW} and \overline{BWE} are High, or \overline{GW} is High and \overline{BWE} is Low and all byte write enable inputs are High.
 5. (n) and (p) indicate the cycles affected by the synchronous control inputs. (n) is the next cycle, (p) is the present cycle.
 6. When $\overline{CE} = H$, \overline{ADSP} is disabled ($\overline{ADSP} = X$). $\overline{ADSP} = L$ to avoid redundancy with the previous truth table entry when $\overline{CE} = H$ and $\overline{ADSP} = H$.

(2) Partial Truth Table for Write Enables (Synchronous Input)

| OPERATION | CLK | \overline{GW} | \overline{BWE} | $\overline{BW1}$ | $\overline{BW2}$ | $\overline{BW3}$ | $\overline{BW4}$ | I/O1 to I/O8 | I/O9 to I/O16 | I/O17 to I/O24 | I/O25 to I/O32 | |
|-----------|-------|--|------------------|------------------|------------------|------------------|------------------|--------------|---------------|----------------|----------------|----------|
| Read | L → H | H | H | x | x | x | x | Dout (n) | Dout (n) | Dout (n) | Dout (n) | |
| | L → H | H | L | H | H | H | H | Dout (n) | Dout (n) | Dout (n) | Dout (n) | |
| Write | L → H | L | x | x | x | x | x | Din (p) | Din (p) | Din (p) | Din (p) | |
| | | | H | L | L | L | L | L | Din (p) | Din (p) | Din (p) | Din (p) |
| | | H | L | L | H | H | H | Din (p) | Hi-Z (p) | Hi-Z (p) | Hi-Z (p) | Hi-Z (p) |
| | | | | H | L | H | H | Hi-Z (p) | Din (p) | Hi-Z (p) | Hi-Z (p) | Hi-Z (p) |
| | | | | H | H | L | H | Hi-Z (p) | Hi-Z (p) | Din (p) | Hi-Z (p) | Hi-Z (p) |
| | | | | H | H | H | L | Hi-Z (p) | Hi-Z (p) | Hi-Z (p) | Hi-Z (p) | Din (p) |
| | | The other 11 combinations of $\overline{BW1}$ to $\overline{BW4}$ are also effective. $\overline{BW1}$ controls I/O1 to I/O8. $\overline{BW2}$ controls I/O9 to I/O16. $\overline{BW3}$ controls I/O17 to I/O24. $\overline{BW4}$ controls I/O25 to I/O32. | | | | | | | | | | |

Note: 1. (n) and (p) indicate the cycles affected by the synchronous control inputs. (n) is the next cycle, (p) is the present cycle.

(3) Asynchronous Truth Table

| OPERATION | \overline{OE} | ZZ | I/O1 to I/O32 |
|------------|-----------------|----|---------------|
| Read | L | L | Dout |
| | H | L | Hi-Z |
| Write | x | L | Din, Hi-Z |
| Deselected | x | L | Hi-Z |
| Snooze | x | H | Hi-Z |

(4) Write Pass-Through Truth Table

| Previous Cycle | | | | Present Cycle | | | | | | | | | | Next Cycle | |
|----------------|------|-------|---------|---------------------------|------|-------|----|-----|-----|------|------|-----|----|-------------|---------|
| Operation | Addr | WRITE | I/O | Operation | Addr | WRITE | CE | CE2 | CE2 | ADSP | ADSC | ADV | OE | I/O | I/O |
| Write Cycle | Ak | L | Dn (Ak) | ADSP Initiated Read Cycle | Am | x | L | L | H | L | x | x | L | Qn (Ak) | Q1 (Am) |
| | | | | ADSC Initiated Read Cycle | Am | H | L | L | H | H | L | x | L | | |
| | | | | Continue Read Cycle | x | H | x | x | x | H | H | L | L | Qn + 1 (Ak) | |
| | | | | | x | H | H | x | x | L | H | L | L | | |

- Note: 1. Dn (Ak) represents input data for the nth burst address starting from address Ak.
 2. Qn (Ak) represents output data from the nth burst address starting from address Ak.
 3. n = 1, 2, 3, or 4
 4. $\overline{\text{WRITE}} = \text{L}$ means that any one or more of the byte write enable inputs ($\overline{\text{BW1}}$, $\overline{\text{BW2}}$, $\overline{\text{BW3}}$, $\overline{\text{BW4}}$) and $\overline{\text{BWE}}$ are Low, or that $\overline{\text{GW}}$ is Low. $\overline{\text{WRITE}} = \text{H}$ means $\overline{\text{GW}}$ and $\overline{\text{BWE}}$ are High, or $\overline{\text{GW}}$ is High and $\overline{\text{BWE}}$ is Low and all byte write enable inputs are High.

(5) Interleaved Burst Sequence (MODE Input = NC or V_{DD})

Bit Order: A₁₄ A₁₃ A₃ A₂ A₁ A₀

The lower 2 bits are internally generated from the external address.

| 1st Address (External) | 2nd Address (Internal) | 3rd Address (Internal) | 4th Address (Internal) |
|------------------------|------------------------|------------------------|------------------------|
| XX XX00 | XX XX01 | XX XX10 | XX XX11 |
| XX XX01 | XX XX00 | XX XX11 | XX XX10 |
| XX XX10 | XX XX11 | XX XX00 | XX XX01 |
| XX XX11 | XX XX10 | XX XX01 | XX XX00 |

The burst address wraps around to its initial state.

(6) Linear Burst Sequence (MODE Input = V_{SS})

Bit Order: A₁₄ A₁₃ A₃ A₂ A₁ A₀

The lower 2 bits are internally generated from the external address.

| 1st Address (External) | 2nd Address (Internal) | 3rd Address (Internal) | 4th Address (Internal) |
|------------------------|------------------------|------------------------|------------------------|
| XX XX00 | XX XX01 | XX XX10 | XX XX11 |
| XX XX01 | XX XX10 | XX XX11 | XX XX00 |
| XX XX10 | XX XX11 | XX XX00 | XX XX01 |
| XX XX11 | XX XX00 | XX XX01 | XX XX10 |

The burst address wraps around to its initial state.

MAXIMUM RATINGS

| SYMBOL | RATING | VALUE | UNIT |
|--------------|------------------------------------|---------------------------------|------|
| V_{DD} | Power Supply Voltage | - 0.5 to 4.6 | V |
| V_{DDQ} | Output Buffer Power Supply Voltage | - 0.5 to V_{DD} | V |
| V_{IN} | Input Terminal Voltage | - 0.5 * to 4.6 | V |
| V_{IO} | Input/Output Terminal Voltage | - 0.5 * to $V_{DDQ} + 0.5^{**}$ | V |
| P_D | Power Dissipation | 1.2 | W |
| T_{solder} | Soldering Temperature (10 s) | 260 | °C |
| T_{strg} | Storage Temperature | - 65 to 150 | °C |
| T_{opr} | Operating Temperature | - 10 to 85 | °C |

*: - 1.5 V with a pulse width of 20% · t_{KC} min (4 ns max)

** : $V_{DDQ} + 1.5$ V with a pulse width of 20% · t_{KC} min (4 ns max)

DC RECOMMENDED OPERATING CONDITIONS (Ta = 0° to 70°C)

| SYMBOL | PARAMETER | MIN | TYP | MAX | UNIT |
|-----------|--|----------------|----------|---------------------|------|
| V_{DD} | Power Supply Voltage | 3.1 | 3.3 | 3.6 | V |
| V_{DDQ} | Output Buffer Power Supply Voltage | 3.1 | 3.3 | 3.6 | V |
| V_{IH} | Input High Voltage | 2.0 | - | $V_{DD} + 0.3^{**}$ | V |
| V_{IH1} | Input High Voltage for MODE Pin | $V_{DD} - 0.3$ | V_{DD} | $V_{DD} + 0.3$ | V |
| V_{IL} | Input Low Voltage | - 0.3 * | - | 0.8 | V |
| V_{IL1} | Input Low Voltage for MODE and NU Pins | - 0.3 | 0.0 | 0.3 | V |

*: - 1.0 V with a pulse width of 20% · t_{KC} min (4 ns max)

** : $V_{DD} + 1.0$ V with a pulse width of 20% · t_{KC} min (4 ns max)

Note: NU pin must be Low or not connected.

DC CHARACTERISTICS (Ta = 0° to 70°C, VDD = VDDQ = 3.1 V to 3.6 V)

| SYMBOL | PARAMETER | TEST CONDITION | MIN | TYP | MAX | UNIT | |
|-------------------|---|--|--|-------|-----|------|----|
| I _{IL} | Input Leakage Current (except MODE, ZZ, NU Pins) | V _{IN} = 0 to V _{DD} | - | - | ± 1 | μA | |
| I _{LO} | Output Leakage Current | Device Deselected or Output Deselected, V _{OUT} = 0 to V _{DD} | - | - | ± 1 | μA | |
| I _I | Input Current | MODE Pin | V _{IN} = V _{DD} to V _{DD} - 0.3 V | - 1 | - | 1 | μA |
| | | | V _{IN} = 0 to 0.3 V | - 100 | - | 1 | |
| | | ZZ Pin | V _{IN} = V _{DD} to 2.0 V | - 1 | - | 100 | |
| | | | V _{IN} = 0 to 0.8 V | - 1 | - | 20 | |
| NU Pin | V _{IN} = 0 to 0.3 V | - 1 | - | 1 | | | |
| V _{OH} | Output High Voltage | I _{OH} = - 8 mA | 2.4 | - | - | V | |
| | | I _{OH} = - 100 μA | V _{DD} - 0.2 | - | - | | |
| V _{OL} | Output Low Voltage | I _{OL} = 8 mA | - | - | 0.4 | V | |
| | | I _{OL} = 100 μA | - | - | 0.2 | | |
| I _{DDO1} | Operating Current | Device Selected, I _{out} = 0 mA All Inputs = V _{IH} /V _{IL} CLK ≥ t _{KC} min | -7 | - | - | 230 | mA |
| | | | -8, -10, -12 | - | - | 220 | |
| I _{DDO2} | Operating Current (idle) | Device Selected, I _{out} = 0 mA ADSC, ADSP, ADV ≥ V _{IH} All Inputs = V _{IH} /V _{IL} , CLK ≥ t _{KC} min | -7 | - | - | 210 | mA |
| | | | -8, -10, -12 | - | - | 190 | |
| I _{DDS1} | Standby Current (CLK Running) | Device Deselected, All Inputs = V _{IH} /V _{IL} CLK ≥ t _{KC} min | -7 | - | - | 45 | mA |
| | | | -8, -10, -12 | - | - | 35 | |
| I _{DDS2} | Standby Current | Device Deselected, All Inputs = V _{DD} - 0.2 V or 0.2 V, CLK frequency = 0 Hz | - | - | 2 | mA | |
| I _{DDS3} | Snooze Current | ZZ = V _{DD} - 0.2 V, All Inputs = V _{IH} /V _{IL} CLK ≥ t _{KC} min | - | - | 2 | mA | |

CAPACITANCE (Ta = 25°C, f = 1.0 MHz)

| SYMBOL | PARAMETER | TEST CONDITION | MAX | UNIT |
|------------------|--|------------------------|-----|------|
| C _{IN} | Input Capacitance | V _{IN} = GND | 5 | pF |
| | Input Capacitance for MODE, ZZ, NU Pin | V _{IN} = GND | 8 | pF |
| C _{I/O} | Input/Output Capacitance | V _{I/O} = GND | 7 | pF |

Note: This parameter is periodically sampled and is not 100% tested.

AC CHARACTERISTICS ($T_a = 0^\circ$ to 70°C , $V_{DD} = V_{DDQ} = 3.1\text{ V}$ to 3.6 V)

| SYMBOL | PARAMETER | TC55V1325FF-7 | | TC55V1325FF-8 | | TC55V1325FF-10 | | TC55V1325FF-12 | | UNIT |
|------------|---|---------------|-----|---------------|-----|----------------|-----|----------------|-----|------|
| | | MIN | MAX | MIN | MAX | MIN | MAX | MIN | MAX | |
| t_{KC} | CLK Cycle Time | 13 | - | 15 | - | 16 | - | 20 | - | ns |
| t_{KH} | CLK High Pulse Width | 5 | - | 5 | - | 5 | - | 6 | - | |
| t_{KL} | CLK Low Pulse Width | 5 | - | 5 | - | 5 | - | 6 | - | |
| t_{KQV} | Access Time from CLK | - | 7 | - | 8 | - | 10 | - | 12 | |
| t_{KQX} | Output Hold Time from CLK | 2 | - | 2 | - | 2 | - | 2 | - | |
| t_{KQLZ} | Output Enable Time from CLK | 5 | - | 5 | - | 5 | - | 5 | - | |
| t_{KQHZ} | Output Disable Time from CLK | 2 | 5 | 2 | 5 | 2 | 5 | 2 | 6 | |
| t_{GQV} | Access Time from \overline{OE} | - | 6 | - | 6 | - | 6 | - | 7 | |
| t_{GQLZ} | Output Enable Time from \overline{OE} | 0 | - | 0 | - | 0 | - | 0 | - | |
| t_{GQHZ} | Output Disable Time from \overline{OE} | 2 | 5 | 2 | 5 | 2 | 5 | 2 | 6 | |
| t_{AS} | Address Input Setup Time from CLK | 2.5 | - | 2.5 | - | 2.5 | - | 3.0 | - | |
| t_{AH} | Address Input Hold Time from CLK | 0.5 | - | 0.5 | - | 0.5 | - | 0.5 | - | |
| t_{ADSS} | \overline{ADSP} , \overline{ADSC} Input Setup Time from CLK | 2.5 | - | 2.5 | - | 2.5 | - | 3.0 | - | |
| t_{ADSH} | \overline{ADSP} , \overline{ADSC} Input Hold Time from CLK | 0.5 | - | 0.5 | - | 0.5 | - | 0.5 | - | |
| t_{AVS} | \overline{ADV} Input Setup Time from CLK | 2.5 | - | 2.5 | - | 2.5 | - | 3.0 | - | |
| t_{AVH} | \overline{ADV} Input Hold Time from CLK | 0.5 | - | 0.5 | - | 0.5 | - | 0.5 | - | |
| t_{WS} | \overline{GW} , \overline{BWE} , $\overline{BW1}$ to $\overline{BW4}$ Input Setup Time from CLK | 2.5 | - | 2.5 | - | 2.5 | - | 3.0 | - | |
| t_{WH} | \overline{GW} , \overline{BWE} , $\overline{BW1}$ to $\overline{BW4}$ Input Hold Time from CLK | 0.5 | - | 0.5 | - | 0.5 | - | 0.5 | - | |
| t_{CES} | \overline{CE} , $\overline{CE2}$, $CE2$ Input Setup Time from CLK | 2.5 | - | 2.5 | - | 2.5 | - | 3.0 | - | |
| t_{CEH} | \overline{CE} , $\overline{CE2}$, $CE2$ Input Hold Time from CLK | 0.5 | - | 0.5 | - | 0.5 | - | 0.5 | - | |
| t_{DS} | Data Setup Time from CLK | 2.5 | - | 2.5 | - | 2.5 | - | 3.0 | - | |
| t_{DH} | Data Hold Time from CLK | 0.5 | - | 0.5 | - | 0.5 | - | 0.5 | - | |
| t_{ZS} | ZZ Standby Time | 5 | - | 5 | - | 5 | - | 6 | - | |
| t_{ZR} | ZZ Recovery Time | 8 | - | 8 | - | 10 | - | 12 | - | |
| t_{ZHZ} | Output Disable Time from ZZ | 0 | 12 | 0 | 12 | 0 | 12 | 0 | 14 | |

AC TEST CONDITIONS

| | |
|---|--------------|
| Input Pulse Level | 3.0 V, 0.0 V |
| Input Pulse Rise and Fall Time | 3 ns |
| Input Timing Measurement Reference Level | 1.5 V |
| Output Timing Measurement Reference Level | 1.5 V |
| Output Load | Fig. 1 |

FIG. 1

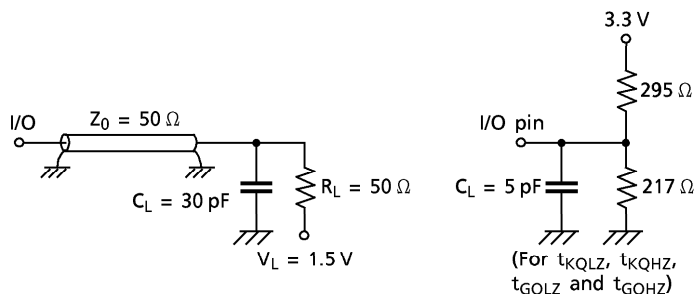

TIMING DIAGRAMS

READ CYCLE

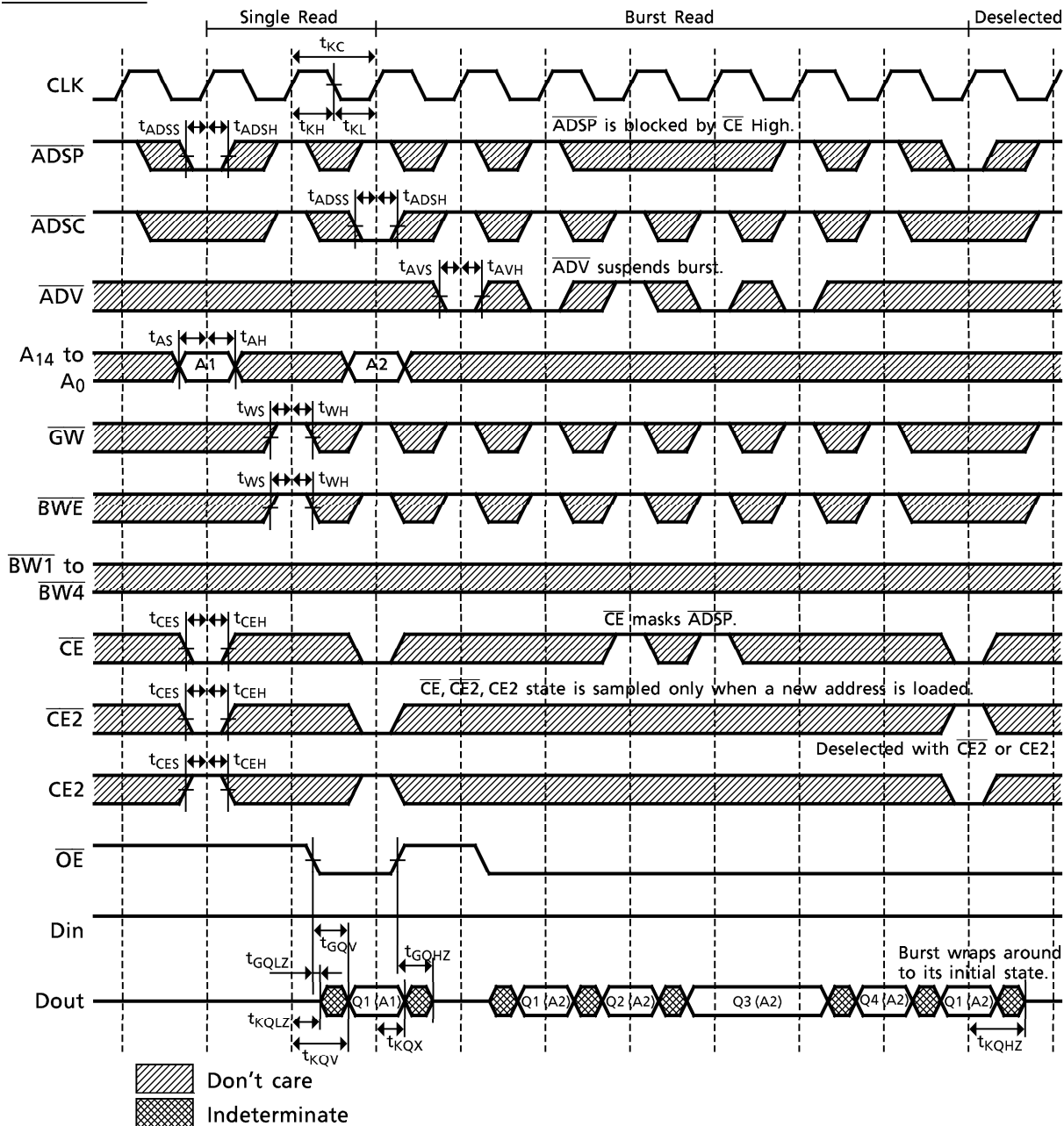

Note:

1. Q1 (A2) represents output data from 1st burst address starting from address A2. Q2 (A2) represents output data from 2nd burst address starting from address A2.
2. ZZ is Low.

WRITE CYCLE

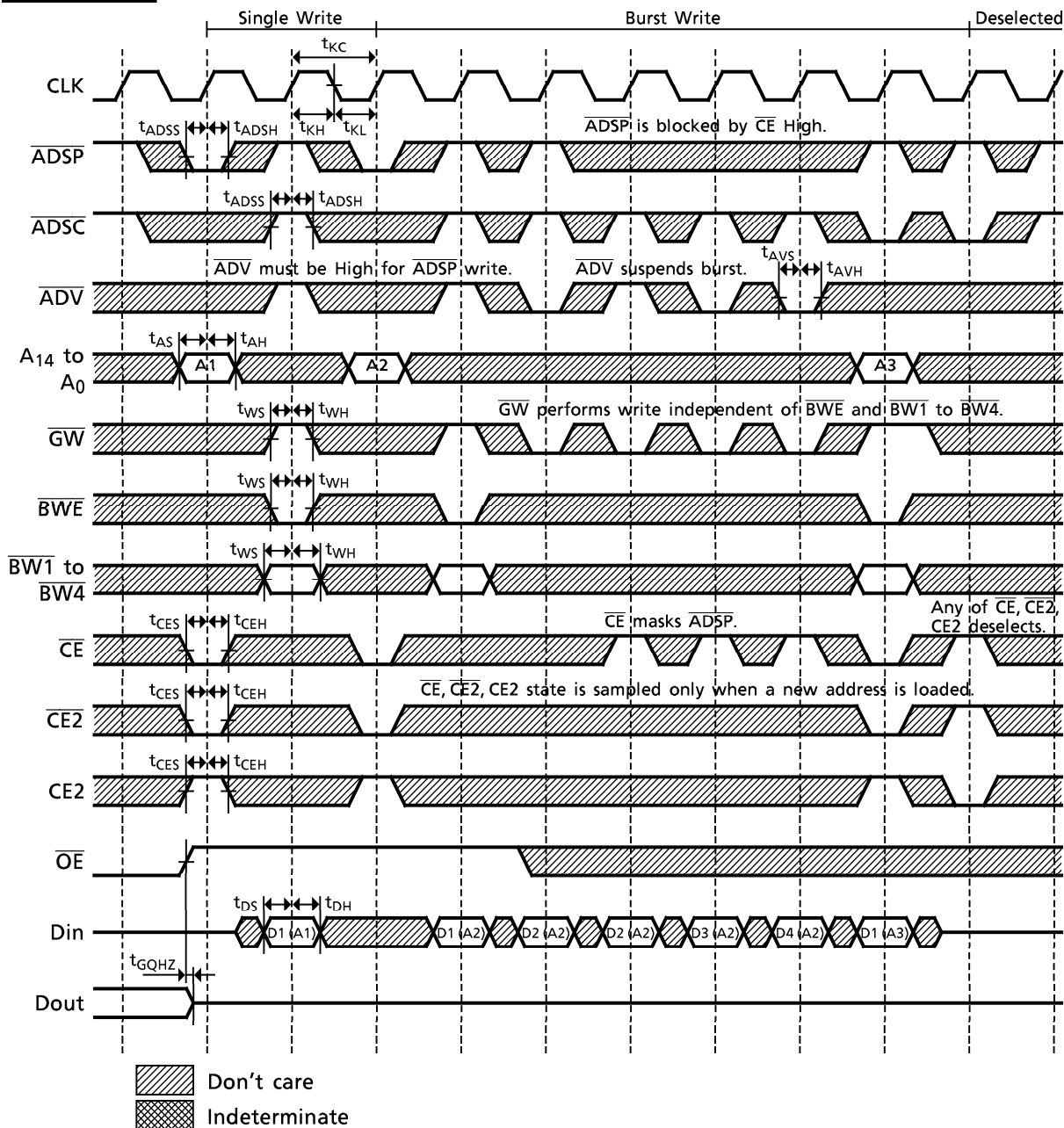

Note:

1. D1 (A2) represents input data for 1st burst address starting from address A2. D2 (A2) represents input data for 2nd burst address starting from address A2.
2. ZZ is Low.

WRITE CYCLE (BYTE WRITE TIMING)

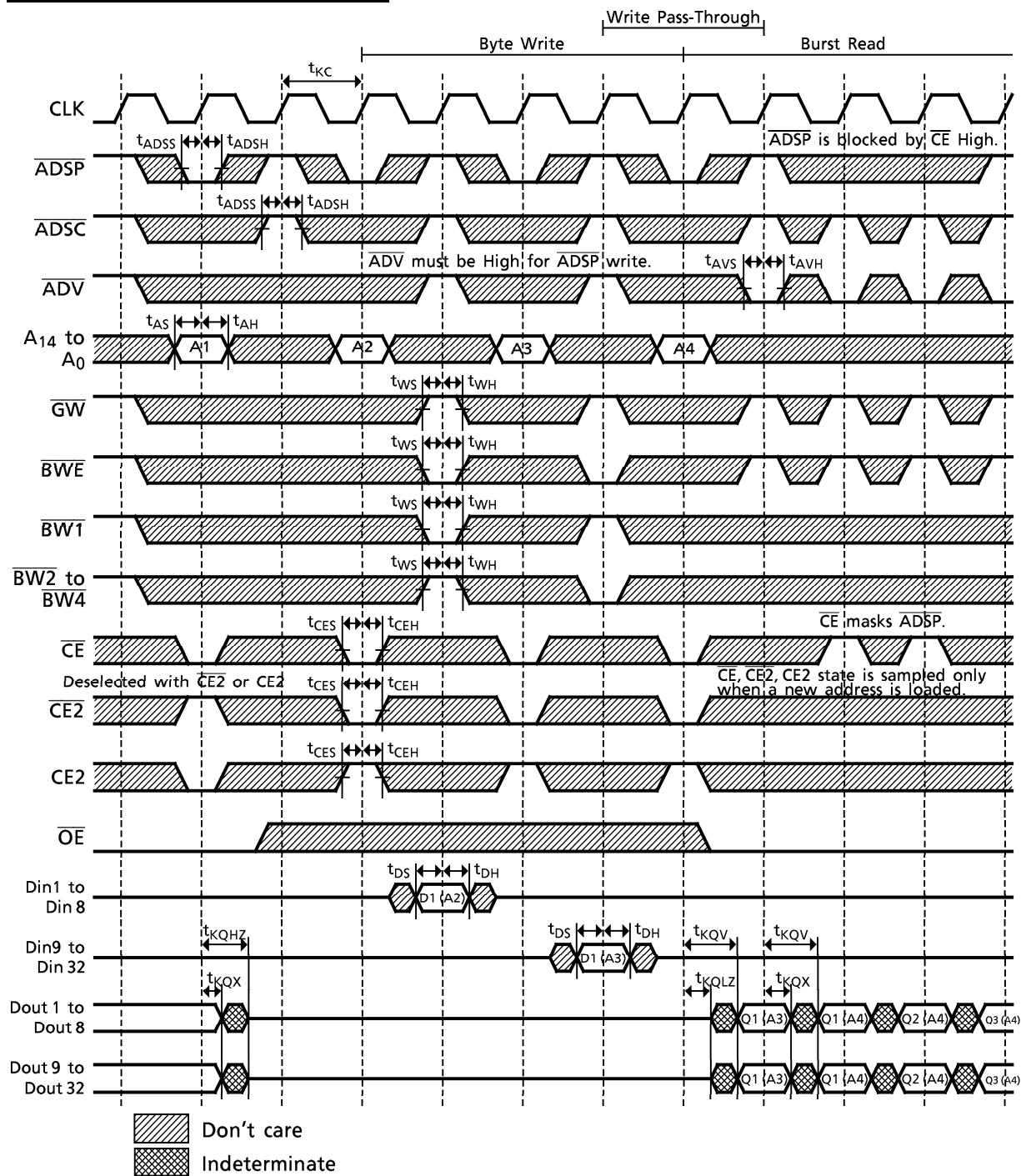

Note:
 1. ZZ is Low.

READ/WRITE CYCLE

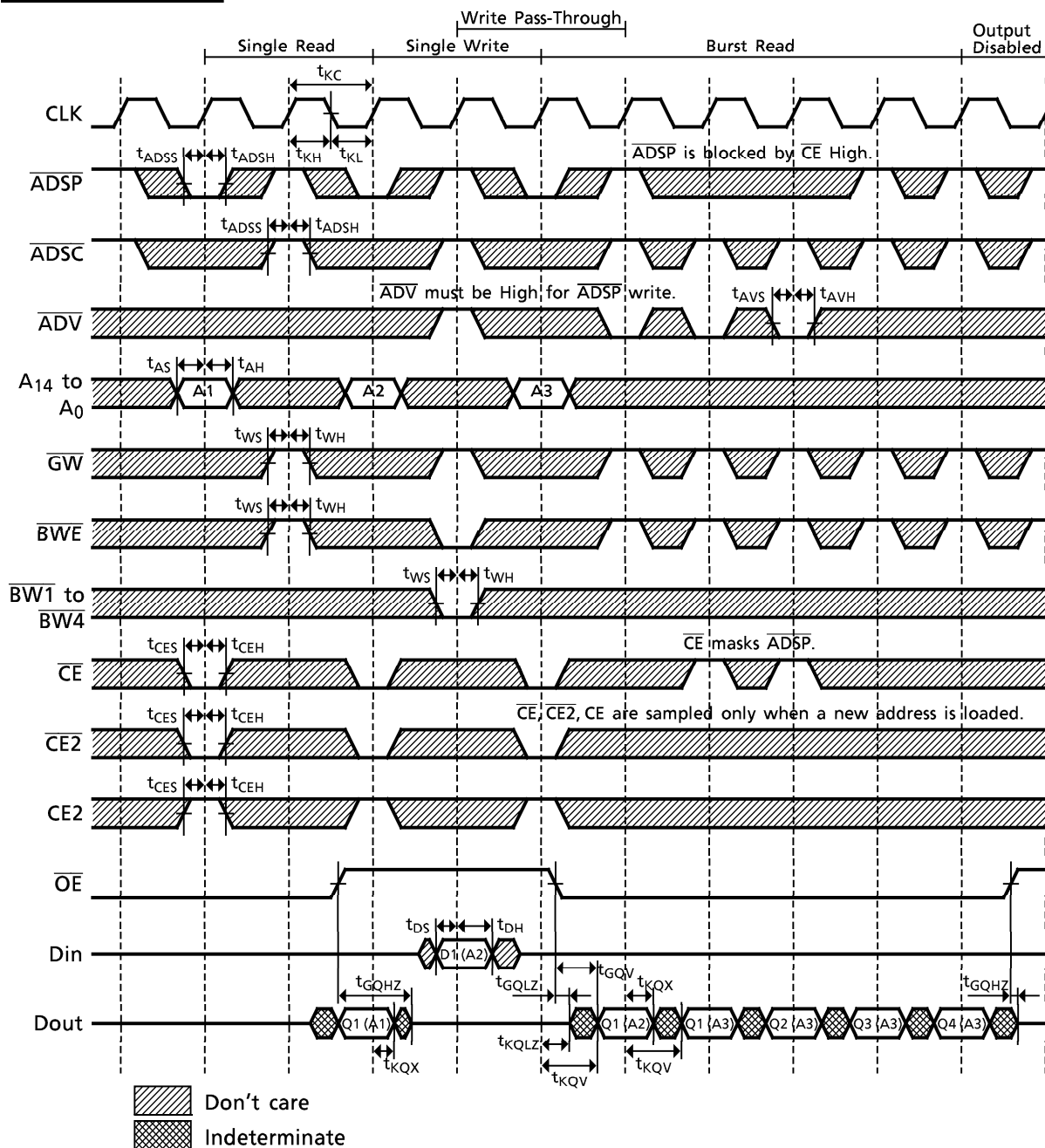

Note:

1. When a write operation follows a read operation, \overline{OE} must be driven High prior to the assertion of the byte write enables (\overline{GW} , \overline{BWE} , $\overline{BW1}$ to $\overline{BW4}$) and before input data is applied to avoid data bus contention.
2. \overline{ZZ} is Low.

SNOOZE CYCLE

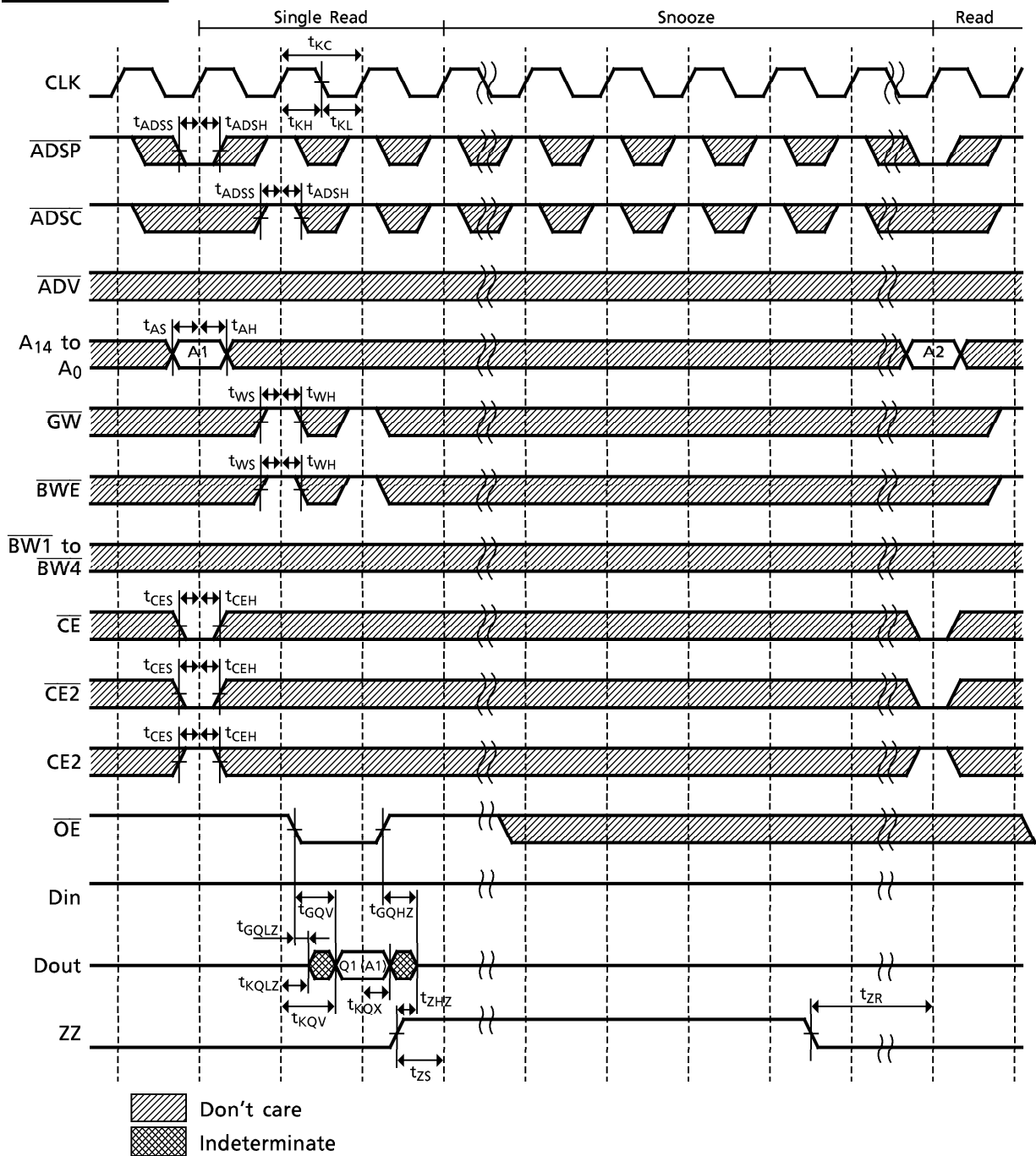

Note: 1. Do not apply opposite data polarity to the I/O pins when they are in the output state.

2. Output enable and output disable times are specified as follows using the output load shown in Fig. 1.

(a) t_{KQLZ} , t_{KQHZ}

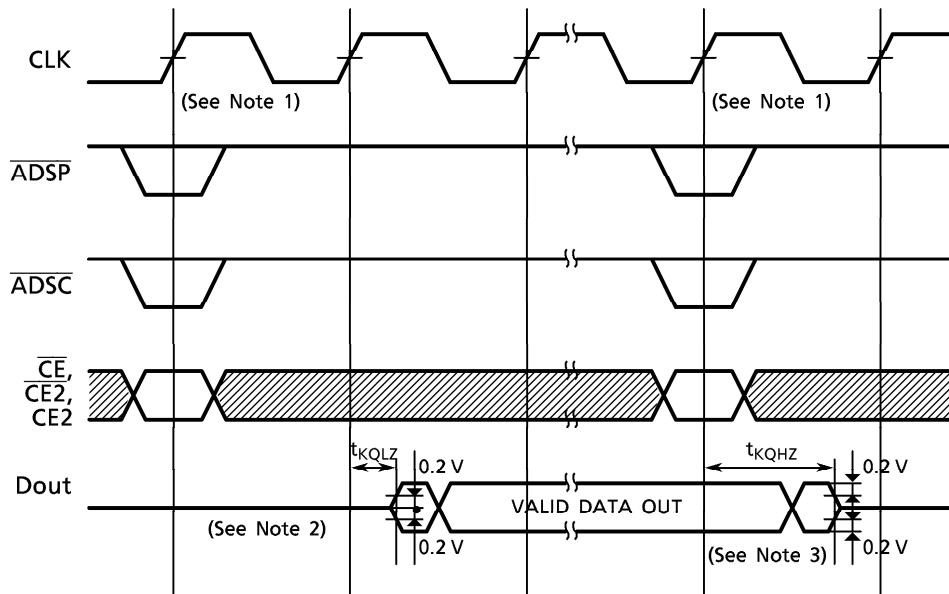

Note:

1. Input states are defined in the Synchronous Input Truth Table.
2. If the device was previously deselected, when the device is selected, the output remains in a high impedance state in the present clock cycle regardless of \overline{OE} because of the output enable delay register. Valid data appears in the second clock cycle when \overline{OE} is low.
3. When the device is deselected, the output goes into a high impedance state in the present clock cycle regardless of \overline{OE} .

(b) t_{GQLZ} , t_{GQHZ} , t_{ZHZ}

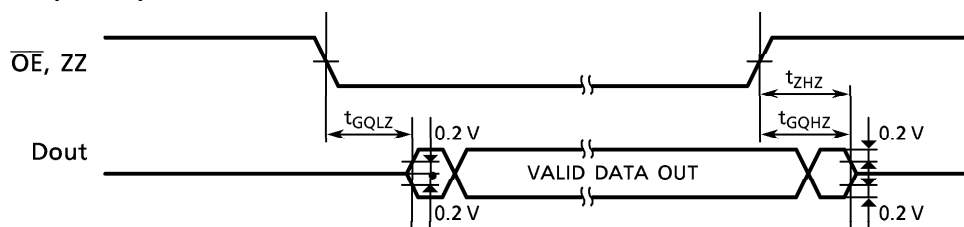

PACKAGE DIMENSIONS

Plastic LQFP (LQFP100-P-1420-0.65K)

Units in mm

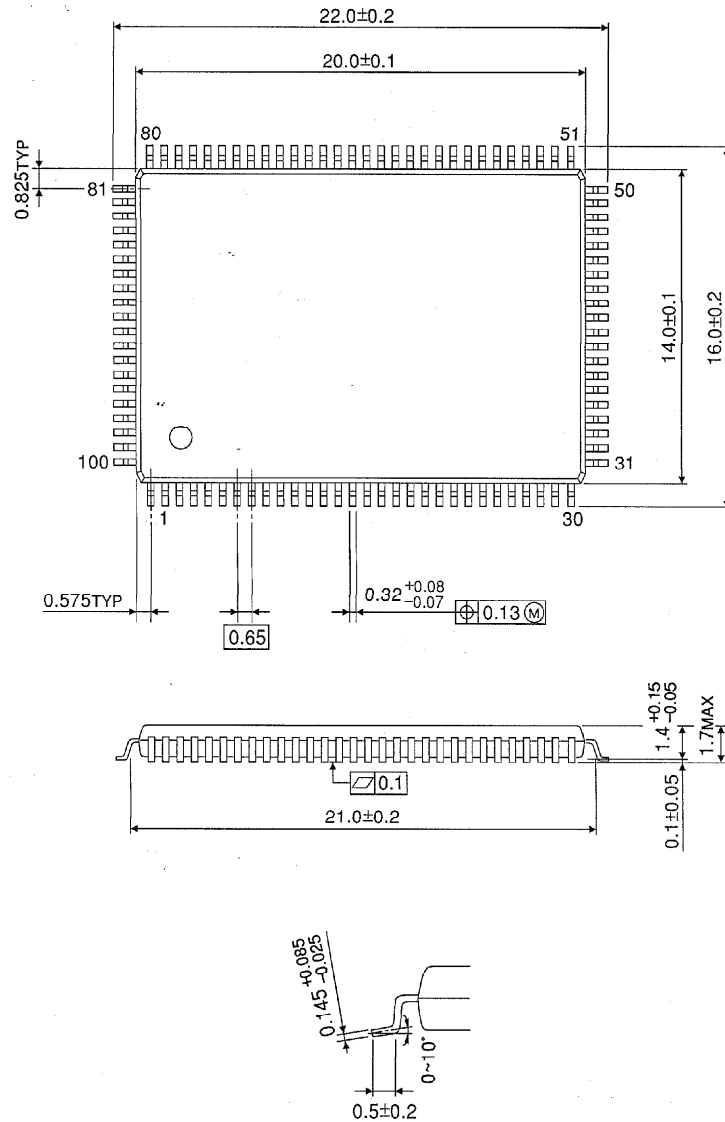

Weight : 0.56 g (typ)