

General Application Information

Steve Contreras

The ASTEC AS431 is a low-cost Precision Temperature Compensated Reference IC that is well-suited for many applications in linear and power electronics. A direct replacement for the industry standard TL431, this IC offers improved AC performance, near zero Temperature Coefficient (TC), trimmed 0.5% tolerance and is available in standard grades from 0 to 105° C and an extended temperature version, the AS1431, from -55 to 125° C.

When used with a minimum of external components, this device is ideal for a wide variety of applications including precision programmable voltage references, high speed amplifiers, comparators, linear series or shunt regulators, current sources or limiters, delay timers, voltage monitors, alarm circuits, and oscillators.

This application note demonstrates the versatility of the AS431 in typical applications and presents data useful for gaining a complete understanding of its application.

Figure 1 shows the schematic symbol and functional block diagram for the AS431. As indicated by the schematic symbol, the device can be thought of as a programmable zener diode. The functional block diagram, however, reveals a versatile IC consisting of a trimmed 2.5 V precision band gap reference, a high speed amplifier (Gain BW Product \approx 3 MHz), ESD protection and a low impedance output stage. It is capable of shunting from 1 to 150 milliamps and has an output voltage range of 2.5 to 30 volts.

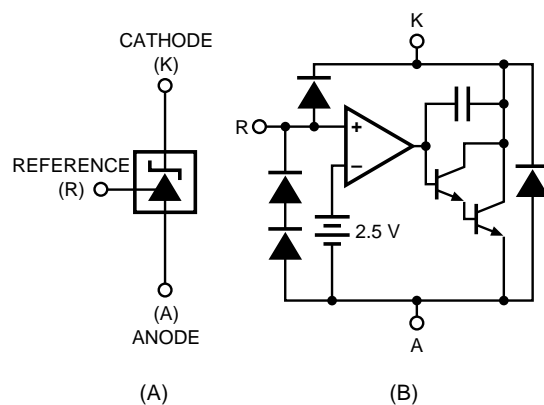

Figure 1. AS431 A) Schematic Symbol
B) Functional Block Diagram

Typical Applications

Precision Voltage Reference

The most common application of the AS431 is a precision temperature compensated voltage reference as shown in Figure 2. Note that only one external resistor is required for an output voltage equal to V_{REF} . For output voltages other than V_{REF} , a simple resistor divider network is used.

Fixed 2.5 Volt Reference

For an output voltage equal to V_{REF} , the reference input pin is connected directly to the cathode. A single resistor R is used to set the cathode current (I_K). The value of R will depend primarily on V_{in} and the characteristics of the load impedance that the circuit output will see (similar to selecting the series resistor for an ordinary zener

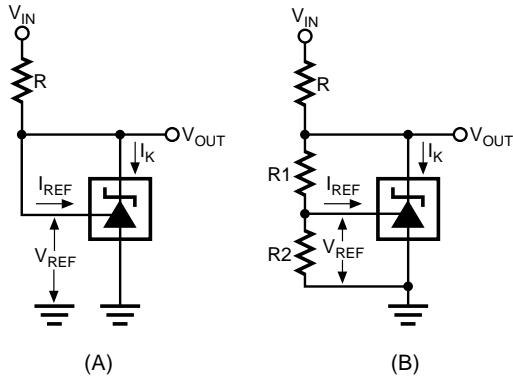

Figure 2. AS431 Precision Voltage Reference
A) Fixed B) Programmable

diode). Generally, R should be chosen to give about 10 mA of cathode current. This will keep the power dissipation low.

Example: Determine the value of R for $V_{IN} = 20$ volts.

The voltage across R is $20 - 2.5 = 17.5$ V. For a desired I_K of 10 mA, $R = 17.5/0.01 = 1.75$ k Ω . Thus, an R of 1.8 k Ω will give an I_K of about 10 mA.

Programmable Output

To program the output to any desired value between V_{REF} and 30 volts, a simple resistor voltage divider is used as shown in Figure 2B.

V_{OUT} is determined by the formula:

$$V_{OUT} = V_{REF} (1 + R1/R2) + I_{REF} \cdot R1.$$

To ensure precise regulation, low TC precision 1% resistors should be used for R1 & R2. Its values should not be so low as to cause excessive power dissipation, nor too high that an error is introduced due to changes in I_{REF} over temperature (I_{REF} is typically 0.7 μ A and deviates 0.4 μ A over the full temperature range). A good compromise is to always keep R2 at around 2 to

5 k Ω and then select R1 to obtain the desired output voltage. The circuit can be made variable by using a potentiometer for R1.

The AS431 As An Error Amplifier

The AS431 can be used in both linear and switch mode power supplies as high gain error amplifier with a built-in temperature compensated voltage reference.

Linear Voltage Regulator

Figure 3 shows a simple linear voltage regulator. This circuit converts an unregulated DC source (rectified AC or battery) to a low-noise, low-ripple precision-regulated DC output. The output voltage can be set to any desired value between 2.5 to 28 volts, and the output current is limited only by the series pass element.

The high gain of the AS431 allows this circuit to achieve a line/load regulation of typically 0.03% or better, depending on the application.

Switch Mode Power Supply

The AS431 can be similarly used in switch mode power supplies as shown in Figure 4. The only difference is the AS431 does not control the

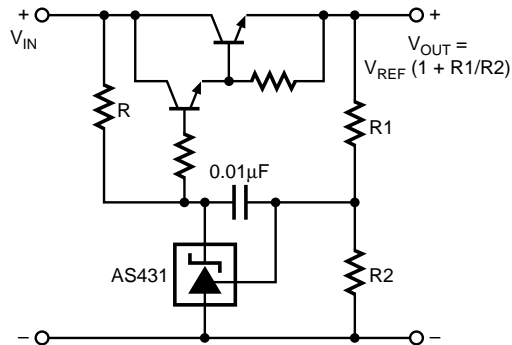

Figure 3. Linear Regulator Using the AS431 as a Reference/Error Amplifier

output voltage directly as in the linear regulator. Instead, it provides an amplified error signal to the PWM circuitry that in turn controls the on/off ratio of the switching device(s), thereby regulating the output voltage. Also, because of the phase shifts and delays associated with the modulator and filter components in switching power supplies, a more elaborate compensation network is required in the control loop to optimize the gain/phase characteristics of system. The network type and values are chosen so as to ensure stability and proper transient response.

Note that there are many different types of switching power supply topologies having different compensation, isolation and PWM configurations. The AS431 and associated circuitry, however, are essentially the same in all cases except for component values, the type of compensation network used and location (it may be located on the primary side in some applications).

The AS431 may also be used for other functions in a switch mode power supply. For example, it can be used as a reference or a comparator in the housekeeping, input/output monitoring, temperature control, or alarm circuitry. Or, as the reference/error amplifier in a MagAmp or linear auxiliary output regulator. Figure 6 illustrates several of these applications.

Frequency Compensation

Frequency compensation of a power supply control loop is achieved with an external compensation network, typically connected between the reference and cathode pins of the AS431. The type of network used can be as simple as a single capacitor, or as elaborate as a dual zero-pole pair network, depending on the power supply's topology. A typical single zero-pole pair compensation network is shown in Figures 4 and 5.

The AS431 typically has 55 dB of gain from DC to 6 kHz, where it rolls off at a 6 dB per octave rate, reaching 0 dB at 3 MHz. Further information characterizing the performance of the AS431 over frequency can be found in the AS431 Data Sheet. Due to the complexity of frequency compensation network design and the vast number of power supply topologies possible, a detailed discussion is beyond the scope of this application note. However, the information provided is useful in determining the compensation needed for a particular application.

The AS431 as a MagAmp Controller

Post regulation is required in many cases for one or more outputs of a switch-mode power supply. Linear regulators incorporating the AS431 are adequate for most low current outputs. When

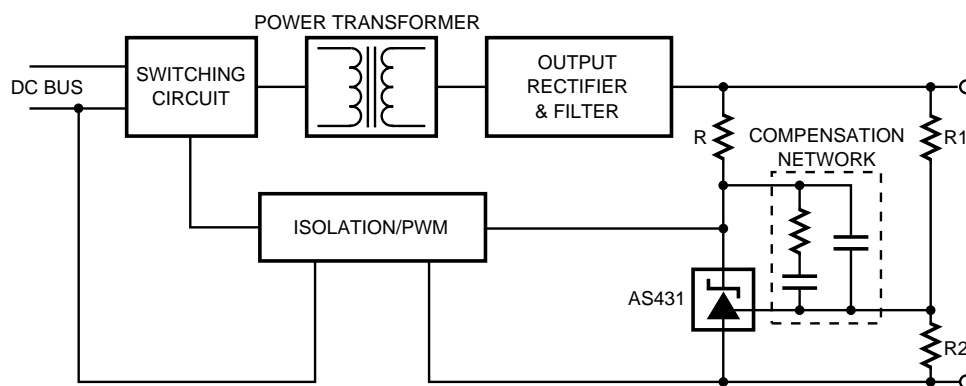

Figure 4. A Switch-Mode Power Supply Using the AS431 as a Reference/Error Amplifier

high current outputs are required, a MagAmp (saturable-core) regulator is usually used because of its high efficiency.

Generally speaking, a MagAmp is a pulse-width modulated buck regulator circuit that uses a saturable core inductor as the switching element. The inductor initially has a high inductance that blocks a pre-determined number of volt-seconds. Upon saturation, the inductor reverts to a very low impedance, which allows current to flow to the output with little loss. The number of volt-seconds blocked in each cycle is defined by the control circuitry and varies in accordance with changes in line and load, providing tight regulation at the output.

The AS431 is an ideal low-cost MagAmp controller, for it contains all the necessary control functions needed (precision reference, high gain

error amplifier and an output stage) in a small package. A schematic diagram of a typical MagAmp post regulator using the AS431 is shown in Figure 5. Since this circuit constitutes a closed loop system, frequency compensation of the error amplifier is necessary.

Other Applications

The AS431 also can replace an ordinary zener diode in any circuit where a higher accuracy and temperature stability is required. Viewing the AS431 as a high gain transistor with a V_{BE} of 2.5 V increases usage possibilities. Applications for this device are limited only by the imagination.

Several practical applications are illustrated in Figure 6.

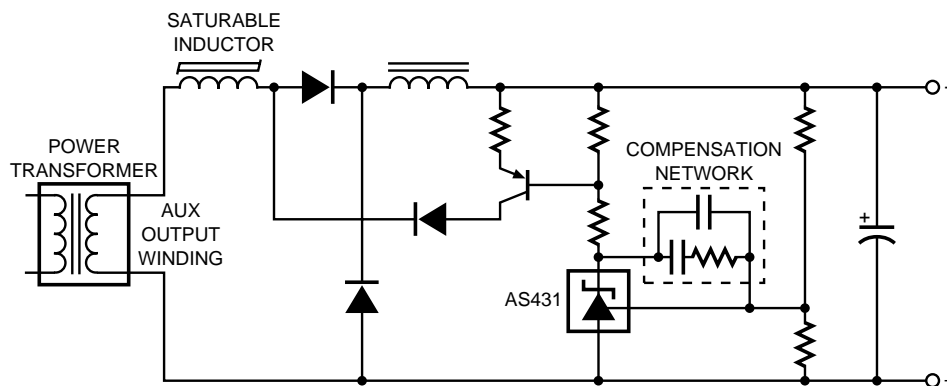

Figure 5. An AS431 Controlled MagAmp Post Regulator

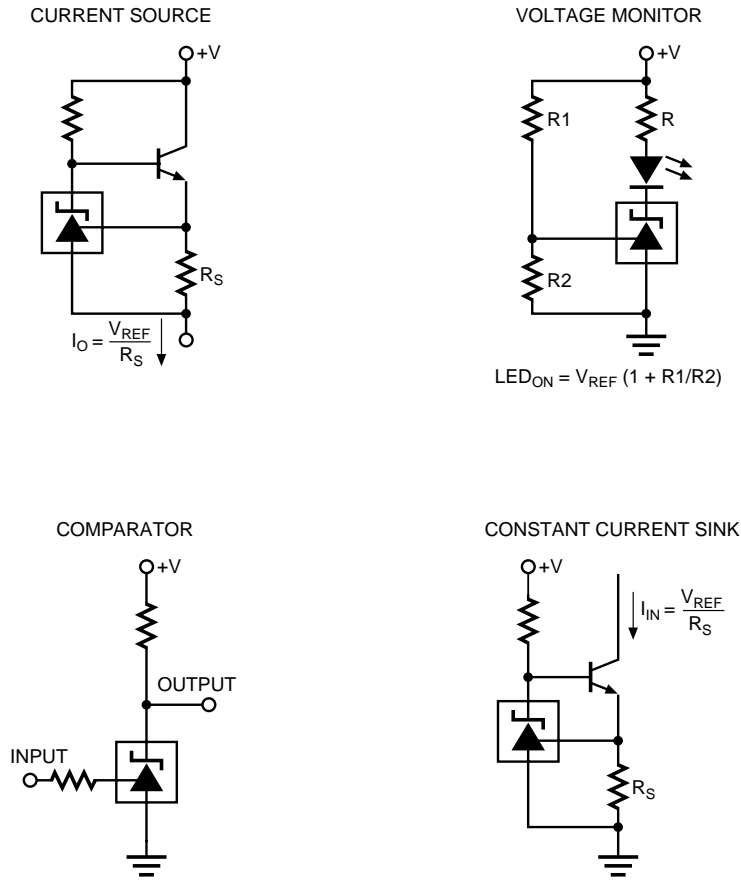

Figure 6. Typical AS431 Applications

ASTEC reserves the right to make changes without further notice to any products described herein to improve reliability, function, or design. ASTEC does not assume any liability arising out of the application or use of any product or circuit described herein; neither does it convey any license under its patent rights or the rights of others. ASTEC products are not authorized for use as components in life support devices or systems intended for surgical implant into the body or intended to support or sustain life. Buyer agrees to notify ASTEC of any such intended end use whereupon ASTEC will determine availability and suitability of its products for the intended use. ASTEC and the ASTEC logo are trademarks of ASTEC (BSR) PLC.

ASTEC SEMICONDUCTOR

255 Sinclair Frontage Road • Milpitas, California 95035 • Tel. (408) 263-8300 • FAX (408) 263-8340