

RENESAS LSIs

M5M5256DFP,VP-55LL,-70LL,-70LLI, -55XL,-70XL

262144-BIT (32768-WORD BY 8-BIT) CMOS STATIC RAM

DESCRIPTION

The M5M5256DFP,VP is 262,144-bit CMOS static RAMs organized as 32,768-words by 8-bits which is fabricated using high-performance 3 poly silicon CMOS technology. The use of resistive load NMOS cells and CMOS periphery results in a high density and low power static RAM. Stand-by current is small enough for battery back-up application. It is ideal for the memory systems which require simple interface.

Especially the M5M5256DVP are packaged in a 28-pin thin small outline package.

FEATURE

Type	Access time (max)	Operating Temperature	Power supply current	
			Active (max)	Stand-by (max)
M5M5256DFP,VP-55LL M5M5256DFP,VP-70LL	55ns 70ns	0~70°C	50mA (V _{CC} =5.5V)	20µA (V _{CC} =5.5V)
M5M5256DFP,VP-70LLI	70ns	-40~85°C		40µA (V _{CC} =5.5V)
M5M5256DFP,VP-55XL M5M5256DFP,VP-70XL	55ns 70ns	0~70°C		5µA (V _{CC} =5.5V) 0.05µA (V _{CC} =3.0V, Typical)

- Single +5V power supply
- No clocks, no refresh
- Data-Hold on +2.0V power supply
- Directly TTL compatible : all inputs and outputs
- Three-state outputs : OR-tie capability
- /OE prevents data contention in the I/O bus
- Common Data I/O
- Battery backup capability
- Low stand-by current 0.05µA(ty.p.)

PACKAGE

M5M5256DFP : 28 pin 450 mil SOP
M5M5256DVP : 28pin 8 X 13.4 mm² TSOP

APPLICATION

Small capacity memory units

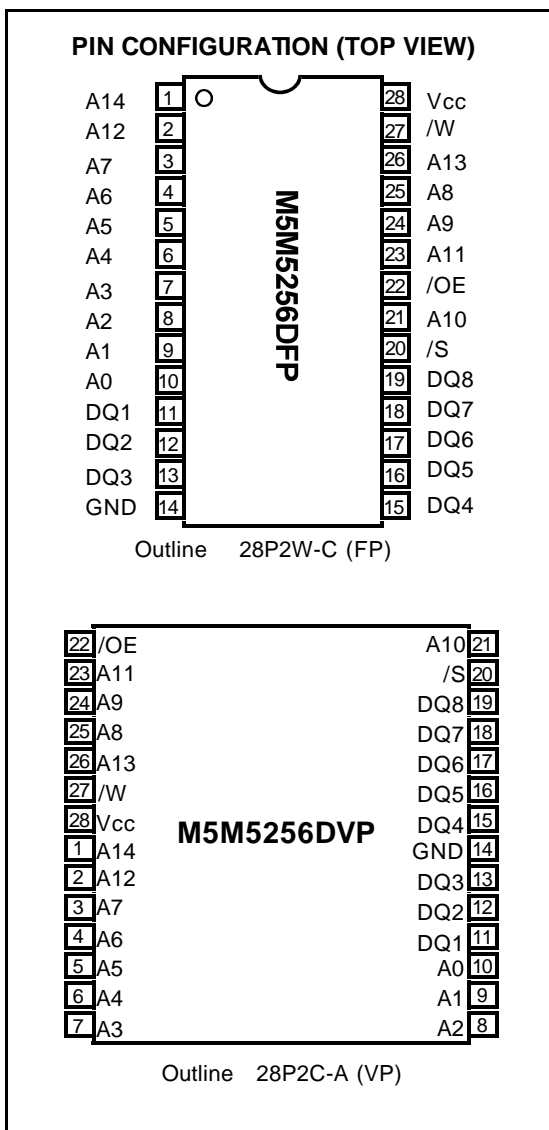

RENESAS LSIs
**M5M5256DFP,VP-55LL,-70LL,-70LLI,
-55XL,-70XL**
262144-BIT (32768-WORD BY 8-BIT) CMOS STATIC RAM

FUNCTION

The operation mode of the M5M5256DFP,VP is determined by a combination of the device control inputs /S, /W and /OE. Each mode is summarized in the function table.

A write cycle is executed whenever the low level /W overlaps with the low level /S. The address must be set up before the write cycle and must be stable during the entire cycle. The data is latched into a cell on the trailing edge of /W, /S, whichever occurs first, requiring the set-up and hold time relative to these edge to be maintained. The output enable /OE directly controls the output stage. Setting the /OE at a high level, the output stage is in a high-impedance state, and the data bus contention problem in the write cycle is eliminated.

A read cycle is executed by setting /W at a high level and /OE at a low level while /S are in an active state.

When setting /S at a high level, the chip is in a non-selectable mode in which both reading and writing are disabled. In this mode, the output stage is in a high-impedance state, allowing OR-tie with other chips and memory expansion by /S. The power supply current is reduced as low as the stand-by current which is specified as Icc3 or Icc4, and the memory data can be held at +2V power supply, enabling battery back-up operation during power failure or power-down operation in the non-selected mode.

FUNCTION TABLE

/S	/W	/OE	Mode	DQ	Icc
H	X	X	Non selection	High-impedance	Stand-by
L	L	X	Write	D _{IN}	Active
L	H	L	Read	D _{OUT}	Active
L	H	H		High-impedance	Active

Note • "H" and "L" in this table mean VIH and VIL, respectively.

• "X" in this table should be "H" or "L".

BLOCK DIAGRAM

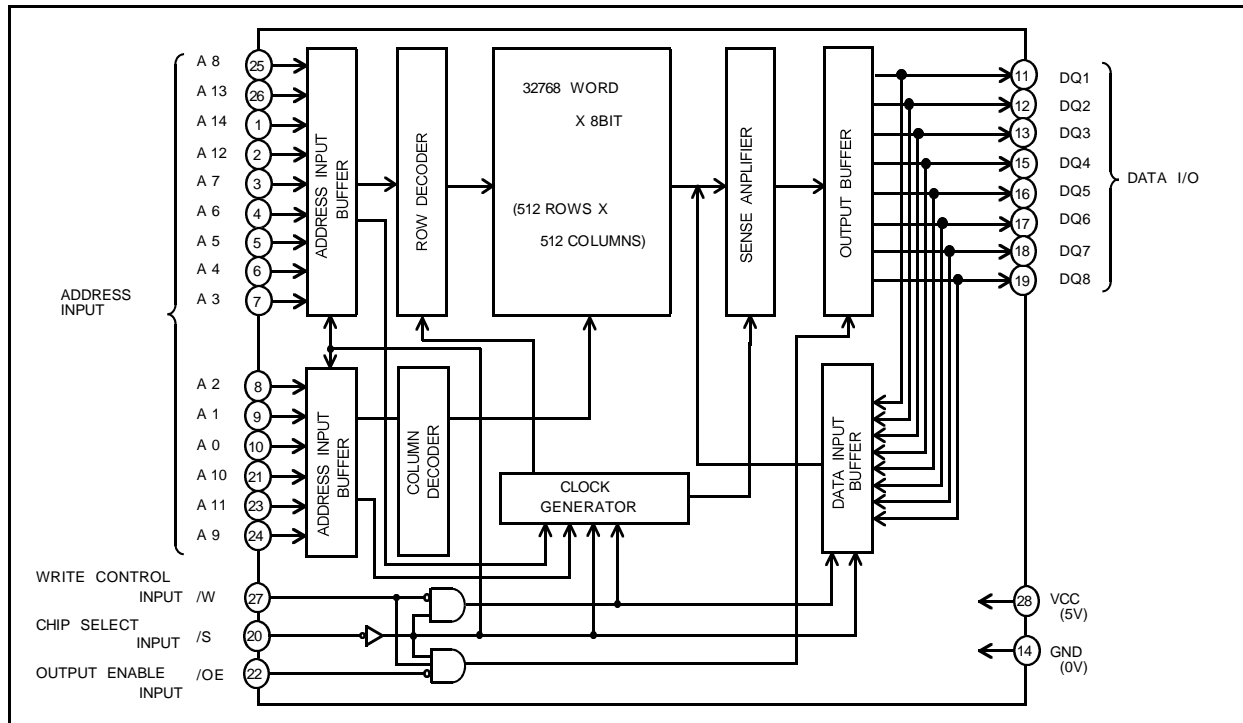

RENESAS LSIs
**M5M5256DFP, VP-55LL, -70LL, -70LLI,
-55XL, -70XL**
262144-BIT (32768-WORD BY 8-BIT) CMOS STATIC RAM

ABSOLUTE MAXIMUM RATINGS

Symbol	Parameter	Conditions	Ratings	Unit
V _{cc}	Supply voltage	With respect to GND	-0.3*~7.0	V
V _i	Input voltage		-0.3*~V _{cc} +0.3 (Max 7.0)	V
V _o	Output voltage		0~V _{cc}	V
P _d	Power dissipation	T _a =25°C	700	mW
T _{opr}	Operating temperature	-LL,-XL	0~70	°C
		-LLI	-40~85	
T _{stg}	Storage temperature		-65~150	°C

* -3.0V in case of AC (Pulse width < 30ns)

DC ELECTRICAL CHARACTERISTICS (V_{cc}=5V±10%, unless otherwise noted)

Symbol	Parameter	Test conditions	Limits			Unit
			Min	Typ	Max	
V _{IH}	High-level input voltage		2.2		V _{cc} +0.3	V
V _{IL}	Low-level input voltage		-0.3*		0.8	V
V _{OH1}	High-level output voltage 1	I _{OH} =-1mA	2.4			V
V _{OH2}	High-level output voltage 2	I _{OH} =-0.1mA	V _{cc} -0.5			V
V _{OL}	Low-level output voltage	I _{OL} =2mA			0.4	V
I _i	Input current	V _i =0~V _{cc}			±1	µA
I _o	Output current in off-state	/S=V _{IH} or /OE=V _{IH} , V _{IO} =0~V _{cc}			±1	µA
I _{cc1}	Active supply current (AC, MOS level)	/S<0.2V, Other inputs<0.2V or >V _{cc} -0.2V Output-open	55ns	30	45	mA
			70ns	25	40	
			1MHz	2	4	
I _{cc2}	Active supply current (AC, TTL level)	/S=V _{IL} , other inputs=V _{IH} or V _{IL} Output-open	55ns	30	50	mA
			70ns	25	45	
			1MHz	4	8	
I _{cc3}	Stand-by current	/S>V _{cc} -0.2V, other inputs=0~V _{cc}	~25°C	-LL,-LLI	2	µA
				-XL	0.1	
			~40°C	-LL,-LLI	6	
				-XL	1.2	
			~70°C	-LL,-LLI	20	
~85°C	-XL	5				
I _{cc4}	Stand-by current	/S=V _{IH} , other inputs=0~V _{cc}			3	mA

* -3.0V in case of AC (Pulse width < 30ns)

CAPACITANCE (V_{cc}=5V±10%, unless otherwise noted)

Symbol	Parameter	Test conditions	Limits			Unit
			Min	Typ	Max	
C _i	Input capacitance	V _i =GND, V _i =25mVrms, f=1MHz			6	pF
C _o	Output capacitance	V _o =GND, V _o =25mVrms, f=1MHz			8	pF

Note 0: Direction for current flowing into an IC is positive (no mark).

1: Typical value is one at T_a = 25°C.

2: C_i, C_o are periodically sampled and are not 100% tested.

RENESAS LSIs
**M5M5256DFP, VP-55LL, -70LL, -70LLI,
-55XL, -70XL**
262144-BIT (32768-WORD BY 8-BIT) CMOS STATIC RAM

AC ELECTRICAL CHARACTERISTICS ($V_{CC}=5V\pm 10\%$, unless otherwise noted)

(1) READ CYCLE

Symbol	Parameter	Limits				Unit
		-55LL, 55XL		-70LL, -70LLI, -70 XL		
		Min	Max	Min	Max	
t_{CR}	Read cycle time	55		70		ns
$t_{a(A)}$	Address access time		55		70	ns
$t_{a(S)}$	Chip select access time		55		70	ns
$t_{a(OE)}$	Output enable access time		30		35	ns
$t_{dis(S)}$	Output disable time after /S high		20		25	ns
$t_{dis(OE)}$	Output disable time after /OE high		20		25	ns
$t_{en(S)}$	Output enable time after /S low	5		5		ns
$t_{en(OE)}$	Output enable time after /OE low	5		5		ns
$t_{v(A)}$	Data valid time after address	10		10		ns

(2) WRITE CYCLE

Symbol	Parameter	Limits				Unit
		-55LL, -55XL		-70LL, -70LLI, -70 XL		
		Min	Max	Min	Max	
t_{CW}	Write cycle time	55		70		ns
$t_{w(W)}$	Write pulse width	40		50		ns
$t_{su(A)}$	Address setup time	0		0		ns
$t_{su(A-WH)}$	Address setup time with respect to /W high	50		65		ns
$t_{su(S)}$	Chip select setup time	50		65		ns
$t_{su(D)}$	Data setup time	25		30		ns
$t_h(D)$	Data hold time	0		0		ns
$t_{rec(W)}$	Write recovery time	0		0		ns
$t_{dis(W)}$	Output disable time from /W low		20		25	ns
$t_{dis(OE)}$	Output disable time from /OE high		20		25	ns
$t_{en(W)}$	Output enable time from /W high	5		5		ns
$t_{en(OE)}$	Output enable time from /OE low	5		5		ns

RENESAS LSIs
**M5M5256DFP, VP-55LL, -70LL, -70LLI,
 -55XL, -70XL**
 262144-BIT (32768-WORD BY 8-BIT) CMOS STATIC RAM

(3) TIMING DIAGRAMS

Read cycle

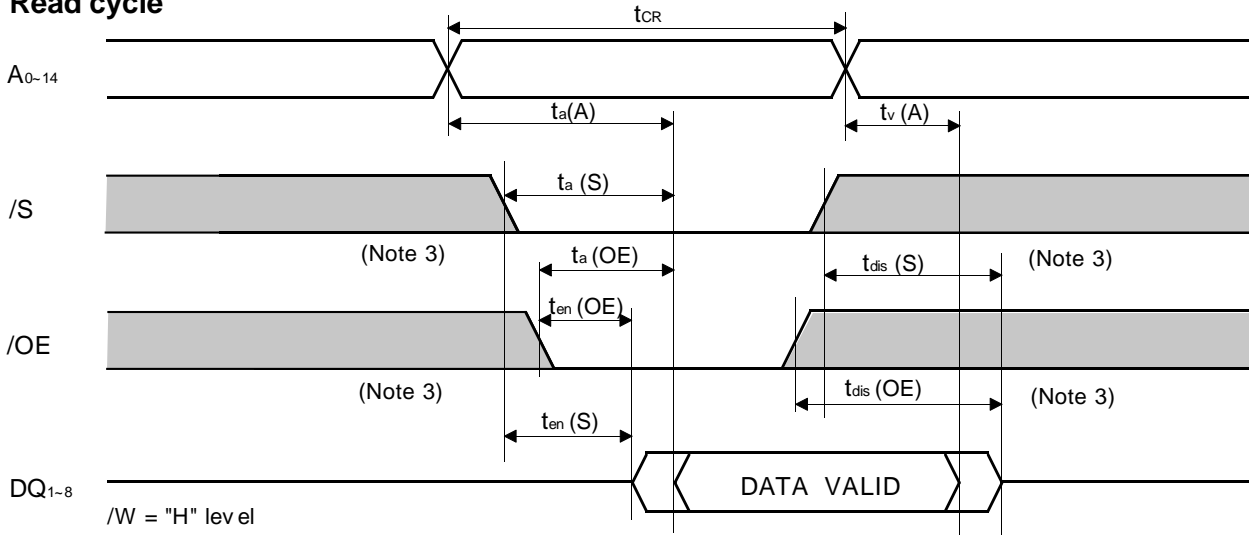

Write cycle (/W control mode)

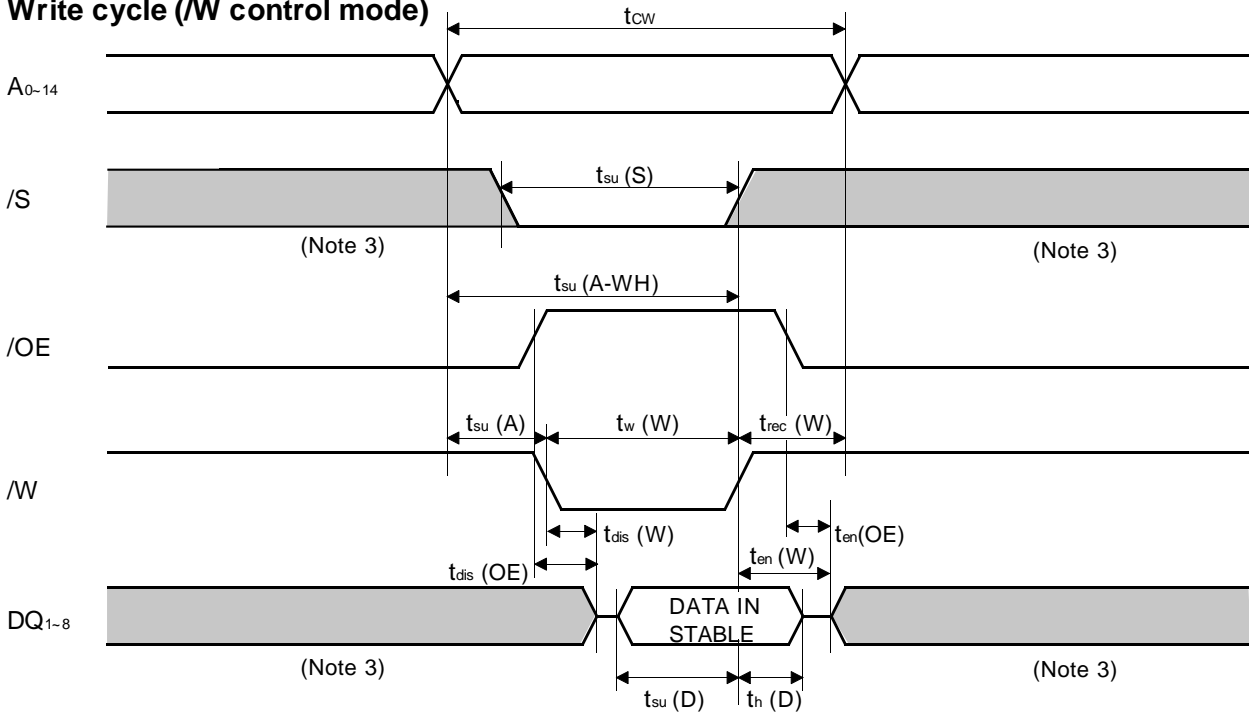

RENESAS LSIs
**M5M5256DFP,VP-55LL,-70LL,-70LLI,
-55XL,-70XL**
262144-BIT (32768-WORD BY 8-BIT) CMOS STATIC RAM

Write cycle (/S control mode)

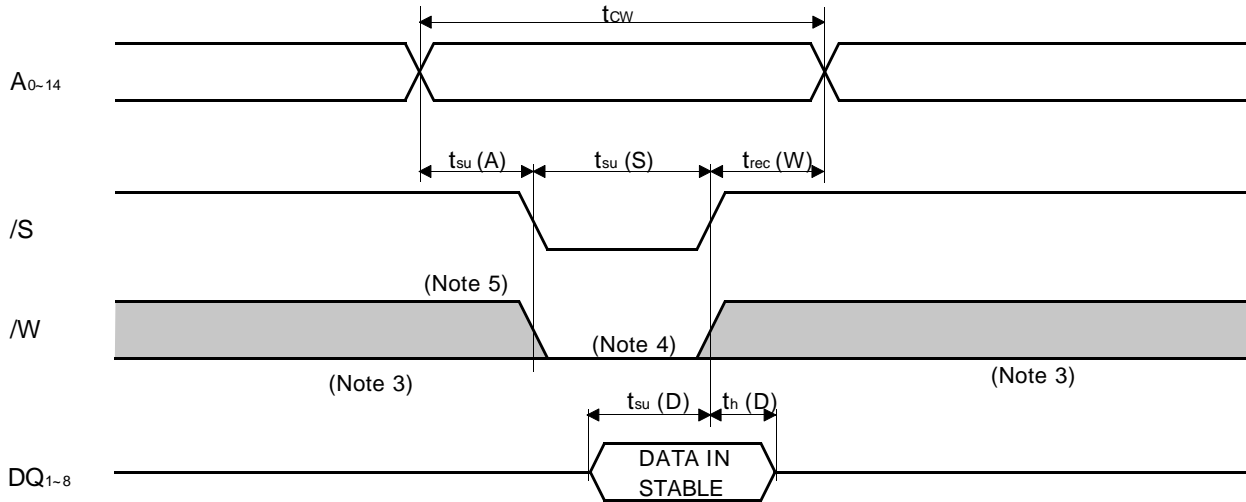

- Note 3 : Hatching indicates the state is "don't care".
- 4 : Writing is executed in overlap of /S and /W low.
- 5 : If /W goes low simultaneously with or prior to /S, the outputs remain in the high impedance state.
- 6 : Don't apply inverted phase signal externally when DQ pin is output mode.
- 7 : t_{en} , t_{dis} are periodically sampled and are not 100% tested.

(4) MEASUREMENT CONDITIONS

- Input pulse level $V_{IH}=2.4V, V_{IL}=0.6V$
- Input rise and fall time 5ns
- Reference level $V_{OH}=V_{OL}=1.5V$
- Output load Fig.1 $CL=50pF$ (-55LL,-55XL)
 $CL=100pF$ (-70LL,-70LLI,-70XL)
 $CL=5pF$ (for t_{en}, t_{dis})
- Transition is measured $\pm 50mV$ from steady state voltage. (for t_{en}, t_{dis})

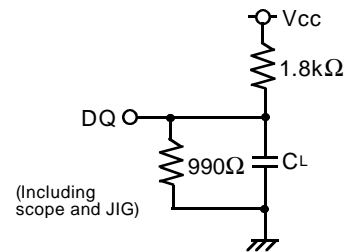

Fig.1 Output load

RENESAS LSIs
**M5M5256DFP, VP-55LL, -70LL, -70LLI,
-55XL, -70XL**
262144-BIT (32768-WORD BY 8-BIT) CMOS STATIC RAM

POWER DOWN CHARACTERISTICS

(1) ELECTRICAL CHARACTERISTICS ($V_{CC}=5V\pm 10\%$, unless otherwise noted)

Symbol	Parameter	Test conditions	Limits			Unit	
			Min	Typ	Max		
$V_{CC(PD)}$	Power down supply voltage		2			V	
$V_I (/S)$	Chip select input /S	$2.2V \leq V_{CC(PD)}$	2.2			V	
		$2V \leq V_{CC(PD)} \leq 2.2V$		$V_{CC(PD)}$		V	
$I_{CC(PD)}$	Power down supply current	$V_{CC} = 3V, /S > V_{CC}-0.2V,$ Other inputs=0~ V_{CC}	~25°C	-LL, -LLI		1	μA
				-XL	0.05	0.2	
			~40°C	-LL, -LLI		3	
				-XL		0.6	
			~70°C	-LL, -LLI		10	
~85°C	-LLI		20				

(2) TIMING REQUIREMENTS ($V_{CC}=5V\pm 10\%$, unless otherwise noted)

Symbol	Parameter	Test conditions	Limits			Unit
			Min	Typ	Max	
$t_{su(PD)}$	Power down set up time		0			ns
$t_{rec(PD)}$	Power down recovery time		tCR			ns

(3) POWER DOWN CHARACTERISTICS

/S control mode

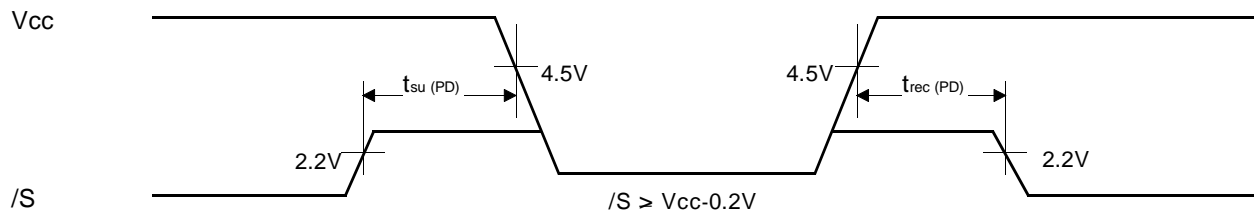

RENESAS LSIs
**M5M5256DFP, VP-55LL, -70LL, -70LLI,
-55XL, -70XL**
262144-BIT (32768-WORD BY 8-BIT) CMOS STATIC RAM

Renesas Technology Corp.

Nippon Bldg., 6-2, Otemachi 2-chome, Chiyoda-ku, Tokyo, 100-0004 Japan

Keep safety first in your circuit designs!

- Renesas Technology Corporation puts the maximum effort into making semiconductor products better and more reliable, but there is always the possibility that trouble may occur with them. Trouble with semiconductors may lead to personal injury, fire or property damage. Remember to give due consideration to safety when making your circuit designs, with appropriate measures such as (i) placement of substitutive, auxiliary circuits, (ii) use of nonflammable material or (iii) prevention against any malfunction or mishap.

Notes regarding these materials

- These materials are intended as a reference to assist our customers in the selection of the Renesas Technology Corporation product best suited to the customer's application; they do not convey any license under any intellectual property rights, or any other rights, belonging to Renesas Technology Corporation or a third party.
- Renesas Technology Corporation assumes no responsibility for any damage, or infringement of any third-party's rights, originating in the use of any product data, diagrams, charts, programs, algorithms, or circuit application examples contained in these materials.
- All information contained in these materials, including product data, diagrams, charts, programs and algorithms represents information on products at the time of publication of these materials, and are subject to change by Renesas Technology Corporation without notice due to product improvements or other reasons. It is therefore recommended that customers contact Renesas Technology Corporation or an authorized Renesas Technology Corporation product distributor for the latest product information before purchasing a product listed herein. The information described here may contain technical inaccuracies or typographical errors.
- Renesas Technology Corporation assumes no responsibility for any damage, liability, or other loss arising from these inaccuracies or errors. Please also pay attention to information published by Renesas Technology Corporation by various means, including the Renesas Technology Corporation Semiconductor home page (<http://www.renesas.com>).
- When using any or all of the information contained in these materials, including product data, diagrams, charts, programs, and algorithms, please be sure to evaluate all information as a total system before making a final decision on the applicability of the information and products. Renesas Technology Corporation assumes no responsibility for any damage, liability or other loss resulting from the information contained herein.
- Renesas Technology Corporation semiconductors are not designed or manufactured for use in a device or system that is used under circumstances in which human life is potentially at stake. Please contact Renesas Technology Corporation or an authorized Renesas Technology Corporation product distributor when considering the use of a product contained herein for any specific purposes, such as apparatus or systems for transportation, vehicular, medical, aerospace, nuclear, or undersea repeater use.
- The prior written approval of Renesas Technology Corporation is necessary to reprint or reproduce in whole or in part these materials.
- If these products or technologies are subject to the Japanese export control restrictions, they must be exported under a license from the Japanese government and cannot be imported into a country other than the approved destination.
Any diversion or reexport contrary to the export control laws and regulations of Japan and/or the country of destination is prohibited.
- Please contact Renesas Technology Corporation for further details on these materials or the products contained therein.