

The RF Sub-Micron MOSFET Line RF Power Field Effect Transistors N-Channel Enhancement-Mode Lateral MOSFETs

Designed for broadband commercial and industrial applications with frequencies from 865 to 895 MHz. The high gain and broadband performance of these devices make them ideal for large-signal, common-source amplifier applications in 26 volt base station equipment.

- Typical CDMA Performance @ 880 MHz, 26 Volts, $I_{DQ} = 700$ mA
IS-97 CDMA Pilot, Sync, Paging, Traffic Codes 8 Through 13
Output Power — 20 Watts
Power Gain — 17.9 dB
Efficiency — 28%
Adjacent Channel Power —
750 kHz: -45.0 dBc @ 30 kHz BW
1.98 MHz: -60.0 dBc @ 30 kHz BW
- Internally Matched, Controlled Q, for Ease of Use
- High Gain, High Efficiency and High Linearity
- Integrated ESD Protection
- Designed for Maximum Gain and Insertion Phase Flatness
- Capable of Handling 10:1 VSWR, @ 26 Vdc, 880 MHz, 90 Watts CW Output Power
- Excellent Thermal Stability
- Characterized with Series Equivalent Large-Signal Impedance Parameters
- Low Gold Plating Thickness on Leads, 40 μ " Nominal.
- In Tape and Reel. R3 Suffix = 250 Units per 56 mm, 13 inch Reel.

MRF9085LR3
MRF9085LSR3

880 MHz, 90 W, 26 V
LATERAL N-CHANNEL
RF POWER MOSFETs

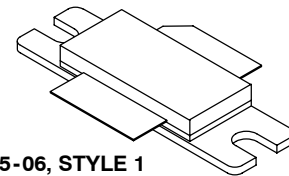

CASE 465-06, STYLE 1
NI-780
MRF9085LR3

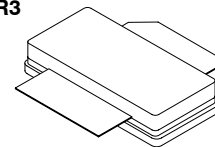

CASE 465A-06, STYLE 1
NI-780S
MRF9085LSR3

MAXIMUM RATINGS

Rating	Symbol	Value	Unit
Drain-Source Voltage	V_{DSS}	65	Vdc
Gate-Source Voltage	V_{GS}	-0.5, +15	Vdc
Total Device Dissipation @ $T_C = 25^\circ\text{C}$ Derate above 25°C	P_D	250 1.43	Watts $\text{W}/^\circ\text{C}$
Storage Temperature Range	T_{stg}	-65 to +150	$^\circ\text{C}$
Operating Junction Temperature	T_J	200	$^\circ\text{C}$

THERMAL CHARACTERISTICS

Characteristic	Symbol	Value (1)	Unit
Thermal Resistance, Junction to Case	$R_{\theta JC}$	0.7	$^\circ\text{C}/\text{W}$

(1) MTTF calculator available at <http://www.motorola.com/semiconductors/xf>. Select Tools/Software/Application Software/Calculators to access the MTTF calculators by product.

NOTE - CAUTION - MOS devices are susceptible to damage from electrostatic charge. Reasonable precautions in handling and packaging MOS devices should be observed.

Freescale Semiconductor, Inc.

ESD PROTECTION CHARACTERISTICS

Test Conditions	Class
Human Body Model	1 (Minimum)
Machine Model MRF9085LR3 MRF9085LSR3	M2 (Minimum) M1 (Minimum)

ELECTRICAL CHARACTERISTICS (T_C = 25°C unless otherwise noted)

Characteristic	Symbol	Min	Typ	Max	Unit
----------------	--------	-----	-----	-----	------

OFF CHARACTERISTICS

Zero Gate Voltage Drain Leakage Current (V _{DS} = 65 Vdc, V _{GS} = 0 Vdc)	I _{DSS}	—	—	10	μAdc
Zero Gate Voltage Drain Leakage Current (V _{DS} = 26 Vdc, V _{GS} = 0 Vdc)	I _{DSS}	—	—	1	μAdc
Gate - Source Leakage Current (V _{GS} = 5 Vdc, V _{DS} = 0 Vdc)	I _{GSS}	—	—	1	μAdc

ON CHARACTERISTICS

Gate Threshold Voltage (V _{DS} = 10 Vdc, I _D = 300 μAdc)	V _{GS(th)}	2.0	—	4.0	Vdc
Gate Quiescent Voltage (V _{DS} = 26 Vdc, I _D = 700 mAdc)	V _{GS(Q)}	—	3.7	—	Vdc
Drain - Source On - Voltage (V _{GS} = 10 Vdc, I _D = 2 Adc)	V _{DS(on)}	—	0.19	0.4	Vdc
Forward Transconductance (V _{DS} = 10 Vdc, I _D = 6 Adc)	g _{fs}	—	8.0	—	S

DYNAMIC CHARACTERISTICS (1)

Output Capacitance (V _{DS} = 26 Vdc ± 30 mV(rms)ac @ 1 MHz, V _{GS} = 0 Vdc)	C _{OSS}	—	73	—	pF
Reverse Transfer Capacitance (V _{DS} = 26 Vdc ± 30 mV(rms)ac @ 1 MHz, V _{GS} = 0 Vdc)	C _{rSS}	—	2.9	—	pF

(1) Part is internally input matched.

(continued)

Freescale Semiconductor, Inc.

ELECTRICAL CHARACTERISTICS - continued ($T_C = 25^\circ\text{C}$ unless otherwise noted)

Characteristic	Symbol	Min	Typ	Max	Unit
FUNCTIONAL TESTS (In Motorola Test Fixture, 50 ohm system)					
Two-Tone Common-Source Amplifier Power Gain ($V_{DD} = 26\text{ Vdc}$, $P_{out} = 90\text{ W PEP}$, $I_{DQ} = 700\text{ mA}$, $f_1 = 880.0\text{ MHz}$, $f_2 = 880.1\text{ MHz}$)	G_{ps}	17	17.9	—	dB
Two-Tone Drain Efficiency ($V_{DD} = 26\text{ Vdc}$, $P_{out} = 90\text{ W PEP}$, $I_{DQ} = 700\text{ mA}$, $f_1 = 880.0\text{ MHz}$, $f_2 = 880.1\text{ MHz}$)	η	36	40	—	%
3rd Order Intermodulation Distortion ($V_{DD} = 26\text{ Vdc}$, $P_{out} = 90\text{ W PEP}$, $I_{DQ} = 700\text{ mA}$, $f_1 = 880.0\text{ MHz}$, $f_2 = 880.1\text{ MHz}$)	IMD	—	-31	-28	dBc
Input Return Loss ($V_{DD} = 26\text{ Vdc}$, $P_{out} = 90\text{ W PEP}$, $I_{DQ} = 700\text{ mA}$, $f_1 = 880.0\text{ MHz}$, $f_2 = 880.1\text{ MHz}$)	IRL	—	-21	-9	dB
Two-Tone Common-Source Amplifier Power Gain ($V_{DD} = 26\text{ Vdc}$, $P_{out} = 90\text{ W PEP}$, $I_{DQ} = 700\text{ mA}$, $f_1 = 865.0\text{ MHz}$, $f_2 = 865.1\text{ MHz}$)	G_{ps}	—	17.9	—	dB
Two-Tone Drain Efficiency ($V_{DD} = 26\text{ Vdc}$, $P_{out} = 90\text{ W PEP}$, $I_{DQ} = 700\text{ mA}$, $f_1 = 865.0\text{ MHz}$, $f_2 = 865.1\text{ MHz}$)	η	—	40.0	—	%
3rd Order Intermodulation Distortion ($V_{DD} = 26\text{ Vdc}$, $P_{out} = 90\text{ W PEP}$, $I_{DQ} = 700\text{ mA}$, $f_1 = 865.0\text{ MHz}$, $f_2 = 865.1\text{ MHz}$)	IMD	—	-31	—	dBc
Input Return Loss ($V_{DD} = 26\text{ Vdc}$, $P_{out} = 90\text{ W PEP}$, $I_{DQ} = 700\text{ mA}$, $f_1 = 865.0\text{ MHz}$, $f_2 = 865.1\text{ MHz}$)	IRL	—	-16	—	dB
Power Output, 1 dB Compression Point, CW ($V_{DD} = 26\text{ Vdc}$, $I_{DQ} = 700\text{ mA}$, $f_1 = 880.0\text{ MHz}$)	P_{1dB}	—	105	—	W
Common-Source Amplifier Power Gain ($V_{DD} = 26\text{ Vdc}$, $P_{out} = 90\text{ W CW}$, $I_{DQ} = 700\text{ mA}$, $f_1 = 880.0\text{ MHz}$)	G_{ps}	—	17.5	—	dB
Drain Efficiency ($V_{DD} = 26\text{ Vdc}$, $P_{out} = 90\text{ W CW}$, $I_{DQ} = 700\text{ mA}$, $f_1 = 880.0\text{ MHz}$)	η	—	51	—	%
Output Mismatch Stress ($V_{DD} = 26\text{ Vdc}$, $P_{out} = 90\text{ W CW}$, $I_{DQ} = 700\text{ mA}$, $f = 880.0\text{ MHz}$, VSWR = 10:1, All Phase Angles at Frequency of Tests)	Ψ	No Degradation In Output Power			
Power Output, 1 dB Compression Point, CW (1) ($V_{DD} = 26\text{ Vdc}$, $I_{DQ} = 700\text{ mA}$, $f_1 = 960\text{ MHz}$)	P_{1dB}	—	105	—	W

(1) These values are derived from a 960 MHz optimized test fixture. Values are not applicable to Figures 1 and 2.

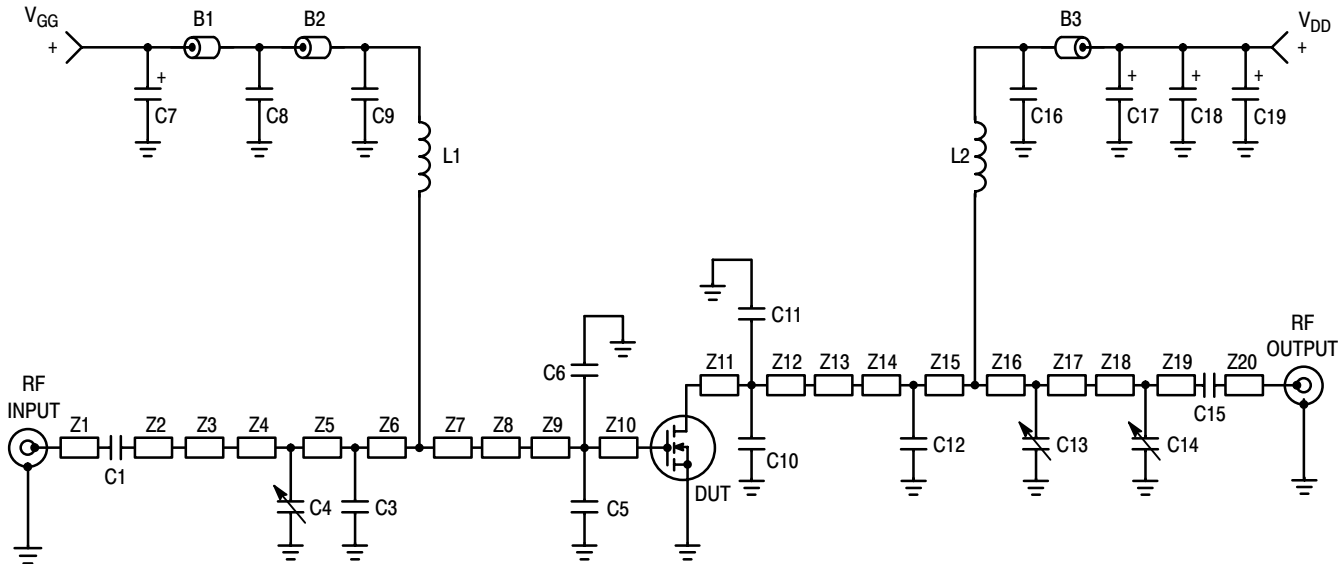

B1, B2, B3	Short Ferrite Beads, Surface Mount	Z6	0.076" x 0.220" Microstrip
C1, C9, C15, C16	47 pF Chip Capacitors, B Case, ATC	Z7	0.261" x 0.220" Microstrip
C3	5.6 pF Chip Capacitor, B Case, ATC	Z8	0.220" x 0.630" x 0.200" Taper
C4, C13	0.8 - 8.0 Variable Capacitors, Gigatrim	Z9	0.240" x 0.630" Microstrip
C5, C6, C12	8.2 pF Chip Capacitors, B Case, ATC	Z10	0.060" x 0.630" Microstrip
C7, C17, C18, C19	10 μ F, 35 V Tantalum Surface Mount Capacitors, Kemet	Z11	0.067" x 0.630" Microstrip
C8	20 K pF Chip Capacitor, B Case, ATC	Z12	0.233" x 0.630" Microstrip
C10, C11	16 pF Chip Capacitors, B Case, ATC	Z13	0.630" x 0.220" x 0.200" Taper
C14	0.6 - 4.5 Variable Capacitor, Gigatrim	Z14	0.200" x 0.220" Microstrip
L1	7.15 nH Inductor, Coilcraft	Z15	0.055" x 0.220" Microstrip
L2	17.5 nH Inductor, Coilcraft	Z16	0.088" x 0.220" Microstrip
N1, N2	N-Type Panel Mount, Stripline, M/A-Com	Z17	0.226" x 0.220" Microstrip
WB1, WB2	5 Mil BeCu Shim (0.225 x 0.525)	Z18	0.868" x 0.080" Microstrip
Z1	0.219" x 0.080" Microstrip	Z19	0.129" x 0.080" Microstrip
Z2	0.150" x 0.080" Microstrip	Z20	0.223" x 0.080" Microstrip
Z3	0.851" x 0.080" Microstrip	PCB	Arlon GX-0300-55-22, 30 mils
Z4	0.125" x 0.220" Microstrip		$\epsilon_r = 2.55$
Z5	0.123" x 0.220" Microstrip		

Figure 1. 865-895 MHz Broadband Test Circuit Schematic

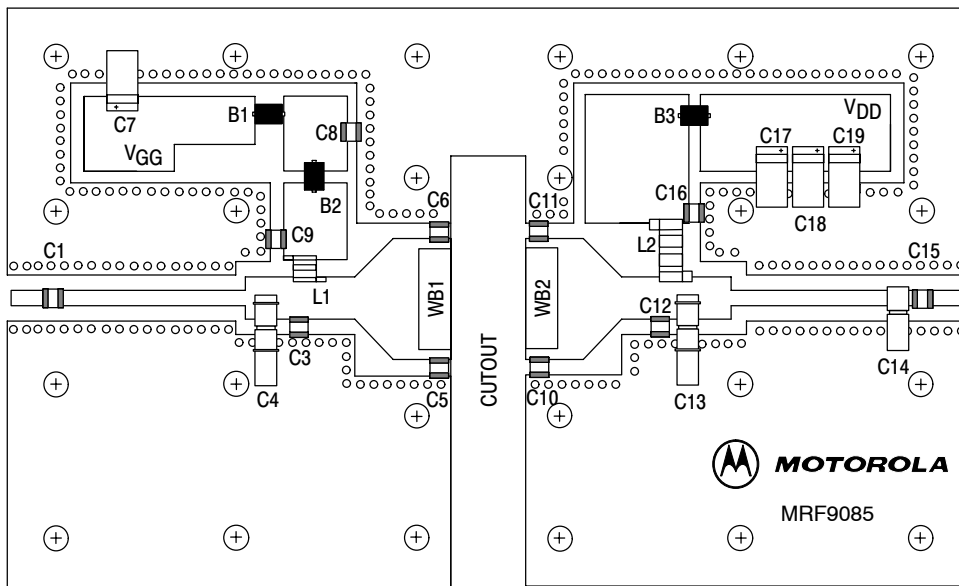

Figure 2. 865-895 MHz Broadband Test Circuit Component Layout

TYPICAL CHARACTERISTICS

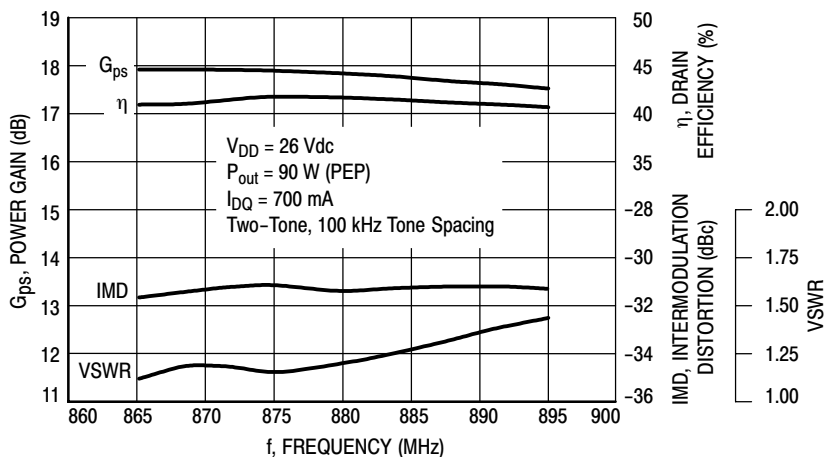

Figure 3. Class AB Broadband Circuit Performance

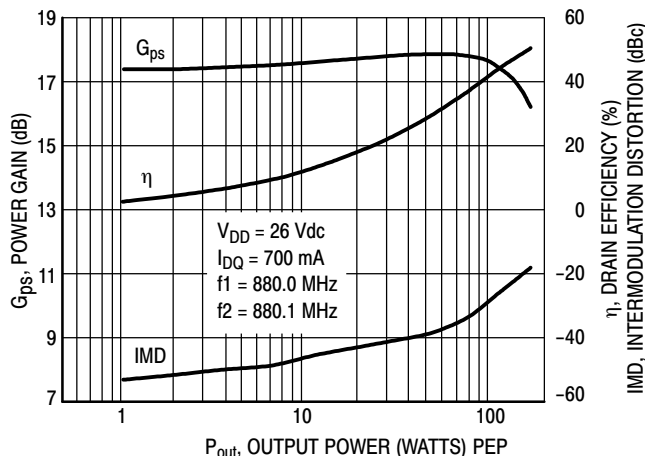

Figure 4. Power Gain, Efficiency, IMD versus Output Power

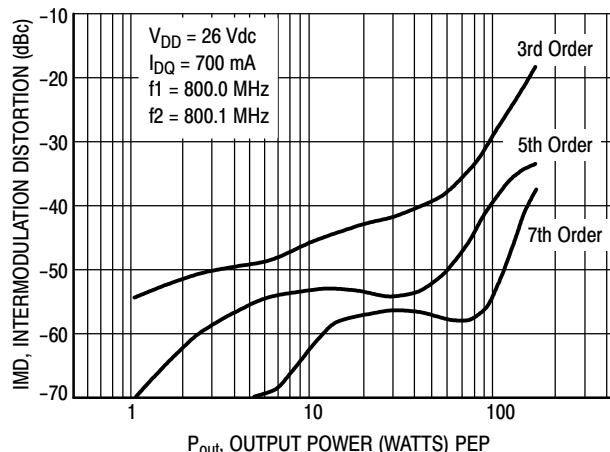

Figure 5. Intermodulation Distortion Products versus Output Power

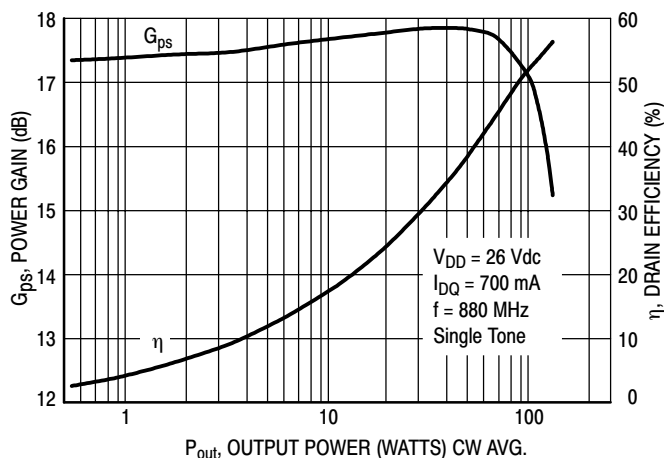

Figure 6. Power Gain, Efficiency versus Output Power

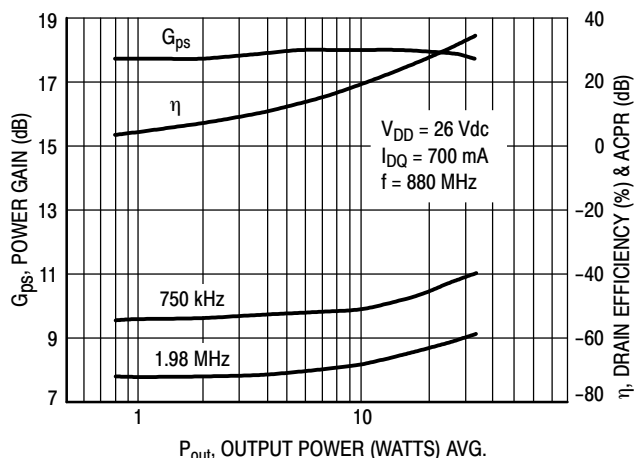
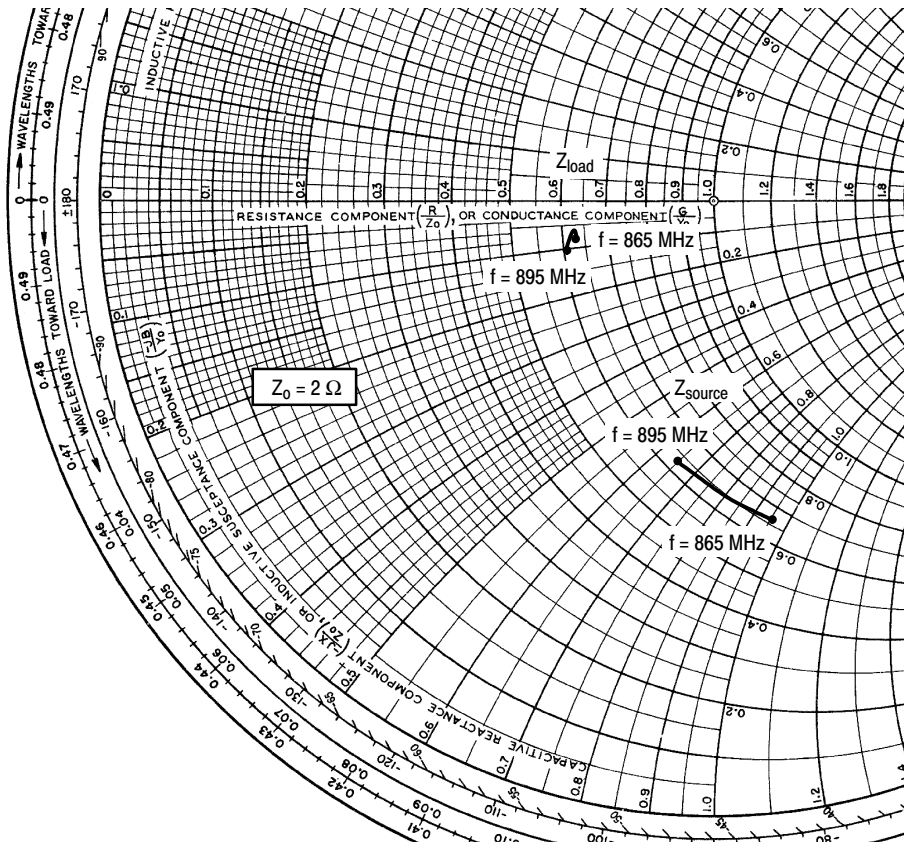

Figure 7. Power Gain, Efficiency, ACPR versus Output Power



$V_{DD} = 26\text{ V}$, $I_{DQ} = 700\text{ mA}$, $P_{out} = 90\text{ W PEP}$

f MHz	Z _{source} Ω	Z _{load} Ω
865	1.35 - j1.92	1.26 - j0.15
880	1.33 - j1.66	1.26 - j0.10
895	1.28 - j1.30	1.21 - j0.20

Z_{source} = Test circuit impedance as measured from gate to ground.

Z_{load} = Test circuit impedance as measured from drain to ground.

Note: Z_{load} was chosen based on tradeoffs between gain, output power, drain efficiency and intermodulation distortion.

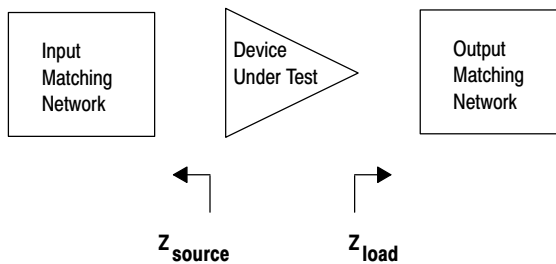
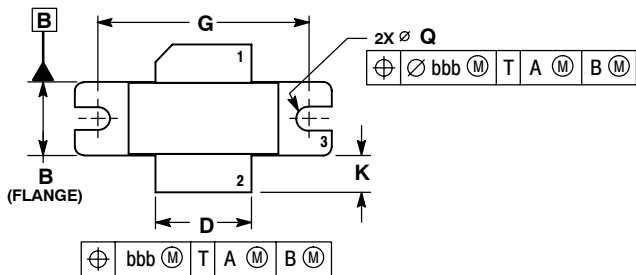

Figure 8. Series Equivalent Input and Output Impedance

Freescale Semiconductor, Inc.

PACKAGE DIMENSIONS



- NOTES:
1. DIMENSIONING AND TOLERANCING PER ANSI Y14.5M-1994.
 2. CONTROLLING DIMENSION: INCH.
 3. DELETED
 4. DIMENSION H IS MEASURED 0.030 (0.762) AWAY FROM PACKAGE BODY.

DIM	INCHES		MILLIMETERS	
	MIN	MAX	MIN	MAX
A	1.335	1.345	33.91	34.16
B	0.380	0.390	9.65	9.91
C	0.125	0.170	3.18	4.32
D	0.495	0.505	12.57	12.83
E	0.035	0.045	0.89	1.14
F	0.003	0.006	0.08	0.15
G	1.100 BSC		27.94 BSC	
H	0.057	0.067	1.45	1.70
K	0.170	0.210	4.32	5.33
M	0.774	0.786	19.66	19.96
N	0.772	0.788	19.60	20.00
Q	∅.118	∅.138	∅3.00	∅3.51
R	0.365	0.375	9.27	9.53
S	0.365	0.375	9.27	9.52
aaa	0.005 REF		0.127 REF	
bbb	0.010 REF		0.254 REF	
ccc	0.015 REF		0.381 REF	

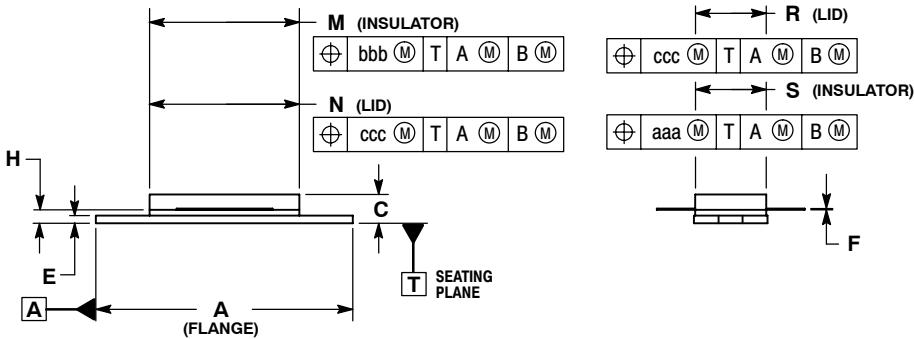

- STYLE 1:
- PIN 1. DRAIN
 - GATE
 - SOURCE

**CASE 465-06
ISSUE F
NI-780
MRF9085LR3**

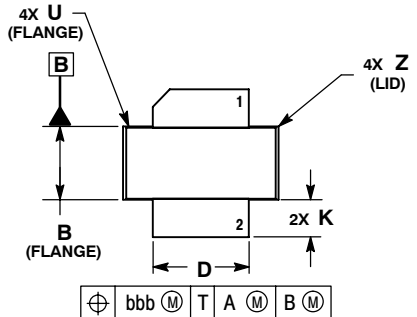

- NOTES:
1. DIMENSIONING AND TOLERANCING PER ANSI Y14.5M-1994.
 2. CONTROLLING DIMENSION: INCH.
 3. DELETED
 4. DIMENSION H IS MEASURED 0.030 (0.762) AWAY FROM PACKAGE BODY.

DIM	INCHES		MILLIMETERS	
	MIN	MAX	MIN	MAX
A	0.805	0.815	20.45	20.70
B	0.380	0.390	9.65	9.91
C	0.125	0.170	3.18	4.32
D	0.495	0.505	12.57	12.83
E	0.035	0.045	0.89	1.14
F	0.003	0.006	0.08	0.15
H	0.057	0.067	1.45	1.70
K	0.170	0.210	4.32	5.33
M	0.774	0.786	19.61	20.02
N	0.772	0.788	19.61	20.02
R	0.365	0.375	9.27	9.53
S	0.365	0.375	9.27	9.52
U	---	0.040	---	1.02
Z	---	0.030	---	0.76
aaa	0.005 REF		0.127 REF	
bbb	0.010 REF		0.254 REF	
ccc	0.015 REF		0.381 REF	

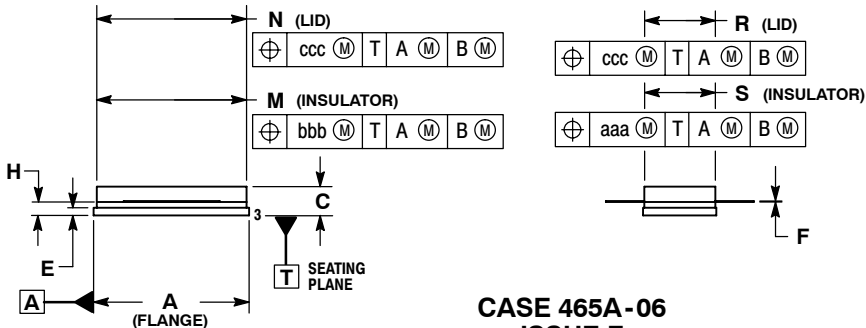

- STYLE 1:
- PIN 1. DRAIN
 - GATE
 - SOURCE

**CASE 465A-06
ISSUE F
NI-780S
MRF9085LSR3**

Freescale Semiconductor, Inc.

Downloaded from Elcodis.com electronic components distributor

Information in this document is provided solely to enable system and software implementers to use Motorola products. There are no express or implied copyright licenses granted hereunder to design or fabricate any integrated circuits or integrated circuits based on the information in this document.

Motorola reserves the right to make changes without further notice to any products herein. Motorola makes no warranty, representation or guarantee regarding the suitability of its products for any particular purpose, nor does Motorola assume any liability arising out of the application or use of any product or circuit, and specifically disclaims any and all liability, including without limitation consequential or incidental damages. "Typical" parameters that may be provided in Motorola data sheets and/or specifications can and do vary in different applications and actual performance may vary over time. All operating parameters, including "Typicals", must be validated for each customer application by customer's technical experts. Motorola does not convey any license under its patent rights nor the rights of others. Motorola products are not designed, intended, or authorized for use as components in systems intended for surgical implant into the body, or other applications intended to support or sustain life, or for any other application in which the failure of the Motorola product could create a situation where personal injury or death may occur. Should Buyer purchase or use Motorola products for any such unintended or unauthorized application, Buyer shall indemnify and hold Motorola and its officers, employees, subsidiaries, affiliates, and distributors harmless against all claims, costs, damages, and expenses, and reasonable attorney fees arising out of, directly or indirectly, any claim of personal injury or death associated with such unintended or unauthorized use, even if such claim alleges that Motorola was negligent regarding the design or manufacture of the part.

MOTOROLA and the Stylized M Logo are registered in the US Patent and Trademark Office. All other product or service names are the property of their respective owners. Motorola, Inc. is an Equal Opportunity/Affirmative Action Employer.

© Motorola Inc. 2004

HOW TO REACH US:

USA/EUROPE/LOCATIONS NOT LISTED:
Motorola Literature Distribution
P.O. Box 5405, Denver, Colorado 80217
1-800-521-6274 or 480-768-2130

JAPAN: Motorola Japan Ltd.; SPS, Technical Information Center,
3-20-1, Minami-Azabu, Minato-ku, Tokyo 106-8573, Japan
81-3-3440-3569

ASIA/PACIFIC: Motorola Semiconductors H.K. Ltd.; Silicon Harbour Centre,
2 Dai King Street, Tai Po Industrial Estate, Tai Po, N.T., Hong Kong
852-26668334

HOME PAGE: <http://motorola.com/semiconductors>



◇ **For More Information On This Product,
Go to: www.freescale.com**

MRF9085/D