

# Audio driver IC for mobile phones

## BH7826FVM

BH7826FVM is an audio driver IC developed for mobile audio products such as mobile phones. Low voltage operation, and low power consumption can be realized. Differential input is available for this IC.

### ●Applications

Mobile phones, PDA, Notebook PC, DSC, DVC

### ●Features

- 1) BTL monaural power amplifier.
- 2) High power 500mW / 8Ω / BTL output.
- 3) Wide supply voltage range.
- 4) For active / shutdown mode.
- 5) Built-in anti-pop circuit / thermal shutdown circuit

### ●External dimensions (Units : mm)

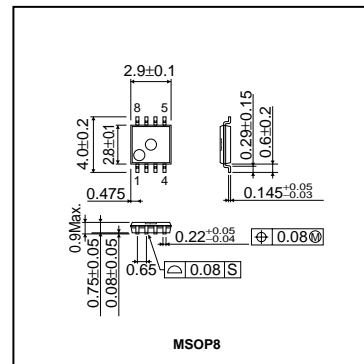

### ●Absolute Maximum Ratings (Ta=25°C)

Parameter	Symbol	Limits	Unit
Applied voltage	Vcc MAX.	6.0	V
Power dissipation	Pd	470 <sup>*1</sup>	mW
Operating temperature range	Topr	-30~+85 <sup>*2</sup>	°C
Storage temperature range	Tstg	-55~+125	°C

<sup>\*1</sup> Derating 4.7mW/°C for operation above Ta=25°C. 70mm×70mm×1.6mm glass epoxy mounting.

<sup>\*2</sup> TOPR=-70~85°C is basic operation range, characteristic and rated output are not guaranteed. In this range if the input signal is exceeded, TSD (Thermal Shutdown) may operate.

### ●Recommended Operating Conditions (Ta=25°C)

Parameter	Symbol	Min.	Typ.	Max.	Unit
Operating supply voltage range	Vccs	2.6	3.6	5.5	V

Communication ICs

●Electrical characteristics (Unless otherwise noted, Ta=27°C, VCC=-3.6V, f=1kHz, RL=8Ω)

Parameter	Symbol	Min.	Typ.	Max.	Unit	Conditions
Circuit current 1	I <sub>CC1</sub>	-	3.5	7	mA	No signal,Active MODE
Circuit current 2	I <sub>CC2</sub>	-	0	2	μA	No signal,Suspend MODE
Voltage gain	G <sub>V1</sub>	+9.5	+11.5	+13.5	dB	V <sub>IN1</sub> =V <sub>IN2</sub> =-20dBV,R <sub>f</sub> /R <sub>s</sub> =100k/22k, SE *1
Maximum output voltage 1	V <sub>OM1</sub>	+4.0	+6.0	-	dBV	DSTN=1% BTL *1
Distortion rate	DSTN	-	0.2	1.0	%	V <sub>IN1</sub> =V <sub>IN2</sub> =-20dBV SE *1
Output residual noise	V <sub>NO</sub>	-	-94	-80	dBV	No signal,SE,Active MODE *2
Suspend attenuation value	G <sub>S</sub>	-	-107	-80	dBV	V <sub>IN1</sub> =V <sub>IN2</sub> =-20dBV,BTL *2
BIAS setting voltage	V <sub>BIAS</sub>	1.6	1.8	2.0	V	3pin DC voltage
Suspend holding voltage / H	V <sub>SH</sub>	2.0	-	V <sub>CC</sub>	V	Active MODE,Hold voltage
Suspend holding voltage / L	V <sub>SL</sub>	0	-	0.5	V	Suspend MODE,Hold voltage

\*1 : B.W.=0.4-30kHz  
 \*2 : DIN AUDIO

●Application Circuit

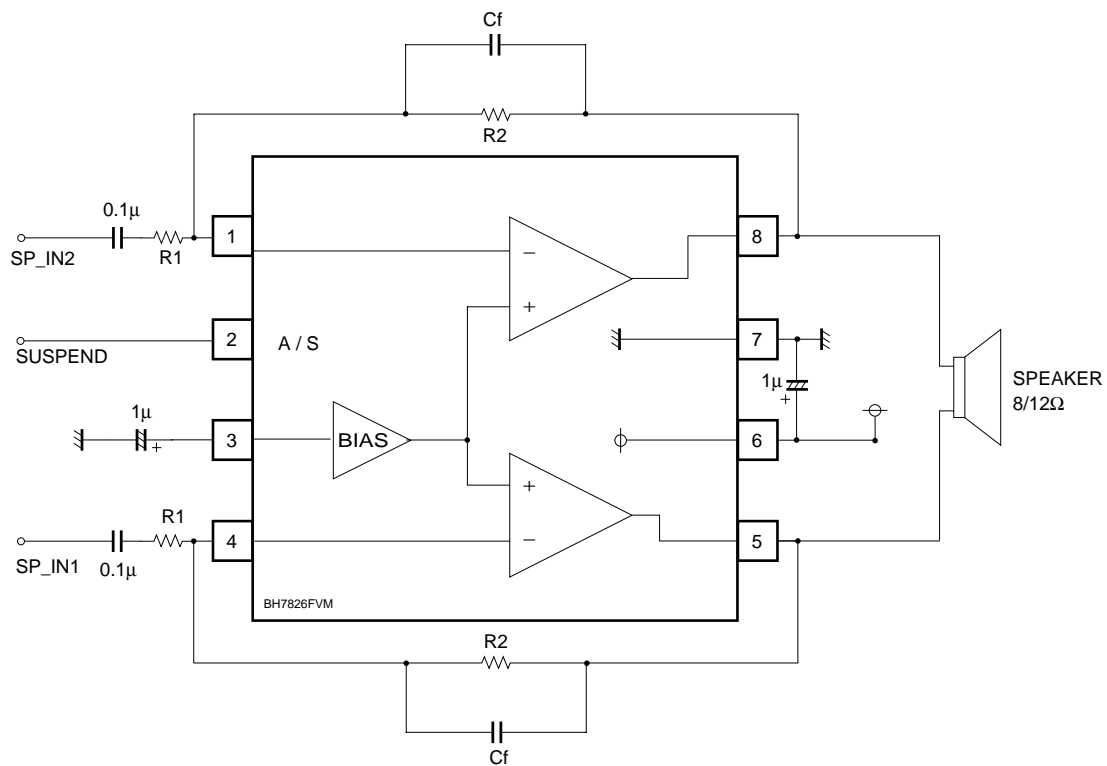

### Notes

- No technical content pages of this document may be reproduced in any form or transmitted by any means without prior permission of ROHM CO.,LTD.
- The contents described herein are subject to change without notice. The specifications for the product described in this document are for reference only. Upon actual use, therefore, please request that specifications to be separately delivered.
- Application circuit diagrams and circuit constants contained herein are shown as examples of standard use and operation. Please pay careful attention to the peripheral conditions when designing circuits and deciding upon circuit constants in the set.
- Any data, including, but not limited to application circuit diagrams information, described herein are intended only as illustrations of such devices and not as the specifications for such devices. ROHM CO.,LTD. disclaims any warranty that any use of such devices shall be free from infringement of any third party's intellectual property rights or other proprietary rights, and further, assumes no liability of whatsoever nature in the event of any such infringement, or arising from or connected with or related to the use of such devices.
- Upon the sale of any such devices, other than for buyer's right to use such devices itself, resell or otherwise dispose of the same, no express or implied right or license to practice or commercially exploit any intellectual property rights or other proprietary rights owned or controlled by ROHM CO., LTD. is granted to any such buyer.
- Products listed in this document use silicon as a basic material.  
Products listed in this document are no antiradiation design.

The products listed in this document are designed to be used with ordinary electronic equipment or devices (such as audio visual equipment, office-automation equipment, communications devices, electrical appliances and electronic toys).

Should you intend to use these products with equipment or devices which require an extremely high level of reliability and the malfunction of which would directly endanger human life (such as medical instruments, transportation equipment, aerospace machinery, nuclear-reactor controllers, fuel controllers and other safety devices), please be sure to consult with our sales representative in advance.

#### About Export Control Order in Japan

Products described herein are the objects of controlled goods in Annex 1 (Item 16) of Export Trade Control Order in Japan.

In case of export from Japan, please confirm if it applies to "objective" criteria or an "informed" (by MITI clause) on the basis of "catch all controls for Non-Proliferation of Weapons of Mass Destruction.