

### Features

- Combined E1 (PCM 30) and T1 (D4/ESF) framer, Line Interface Unit (LIU) and link controller with optional digital framer only mode
- In T1 mode the LIU can recover signals attenuated by up to 36 dB (6000 ft. of 24 AWG cable)
- In E1 mode the LIU can recover signals attenuated by up to 36 dB (2000 m. of 0.65mm cable)
- Two HDLCs: FDL and channel 24 in T1 mode, timeslot 0 (S<sub>a</sub> bits) and timeslot 16 in E1 mode
- Two-frame elastic buffer in Rx & Tx (T1) directions
- Programmable transmit delay through transmit slip buffer
- Low jitter DPLL for clock generation
- Enhanced alarms, performance monitoring and error insertion functions
- Intel or Motorola non-multiplexed parallel microprocessor interface
- ST-BUS 2.048 Mbit/s backplane bus for both data and signaling
- Japan Telecom J1 Framing and Yellow Alarm
- Hardware data link access
- JTAG Boundary Scan

### Applications

- E1/T1 add/drop multiplexers and channel banks
- CO and PBX equipment interfaces
- Primary Rate ISDN nodes
- Digital Cross-connect Systems (DCS)

DS5024

ISSUE 5

September 1999

#### Ordering Information

MT9074AP	68 Pin PLCC
MT9074AL	100 Pin MQFP
<b>-40°C to 85°C</b>	

### Description

The MT9074 is a single chip device, operable in either T1 or E1 mode, integrating either an advanced T1 (T1 mode) or PCM 30 (E1 mode) framer with a Line Interface Unit (LIU).

The framer interfaces to a 2.048 Mbit/s backplane providing selectable data link access with optional HDLC controllers for either the FDL bits and channel 24 (T1 mode) or S<sub>a</sub> bits and channel 16 (E1 mode). The LIU interfaces the framer to T1 (T1 mode) or PCM 30 (E1 mode) transformer-isolated four-wire line with minimal external components required.

In T1 mode the MT9074 supports D4, ESF and SLC-96 formats, meeting the latest recommendations including ITU I.431, AT&T PUB43801, TR-62411, ANSI T1.102, T1.403 and T1.408. In E1 mode the MT9074 supports the latest ITU-T Recommendations including G.703, G.704, G.706, G.732, G.775, G.796, G.823 for PCM 30, and I.431 for ISDN primary rate. It also supports ETSI ETS 300 011, ETS 300 166 and ETS 300 233.

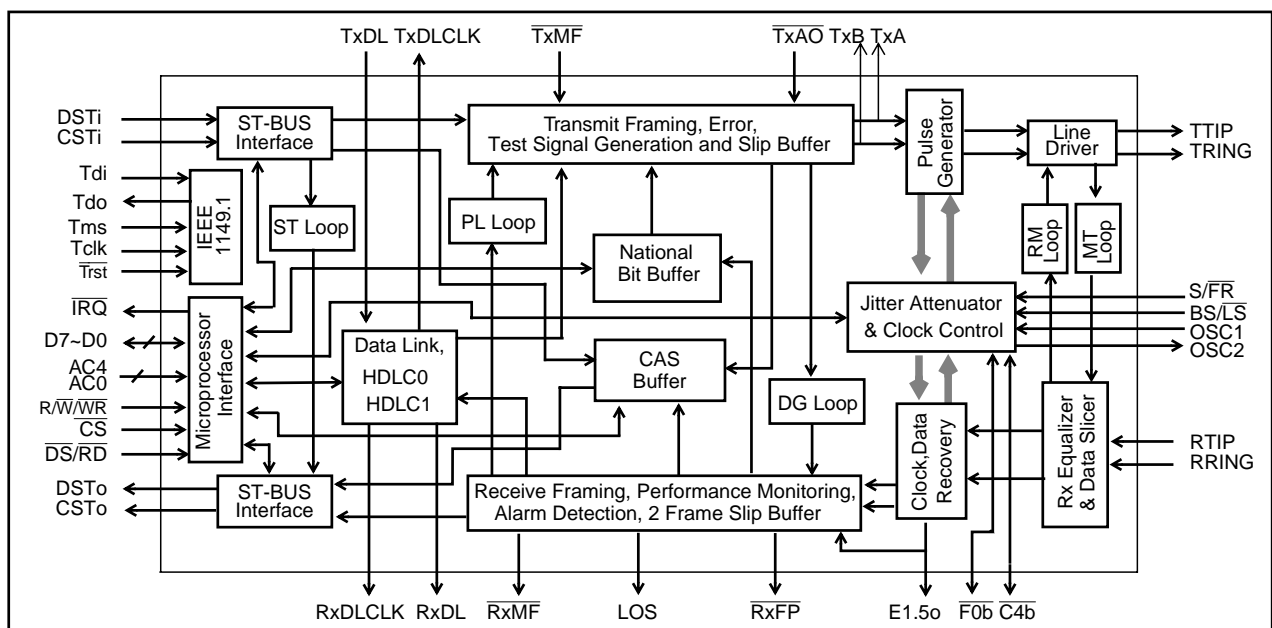

**Figure 1 - Functional Block Diagram**

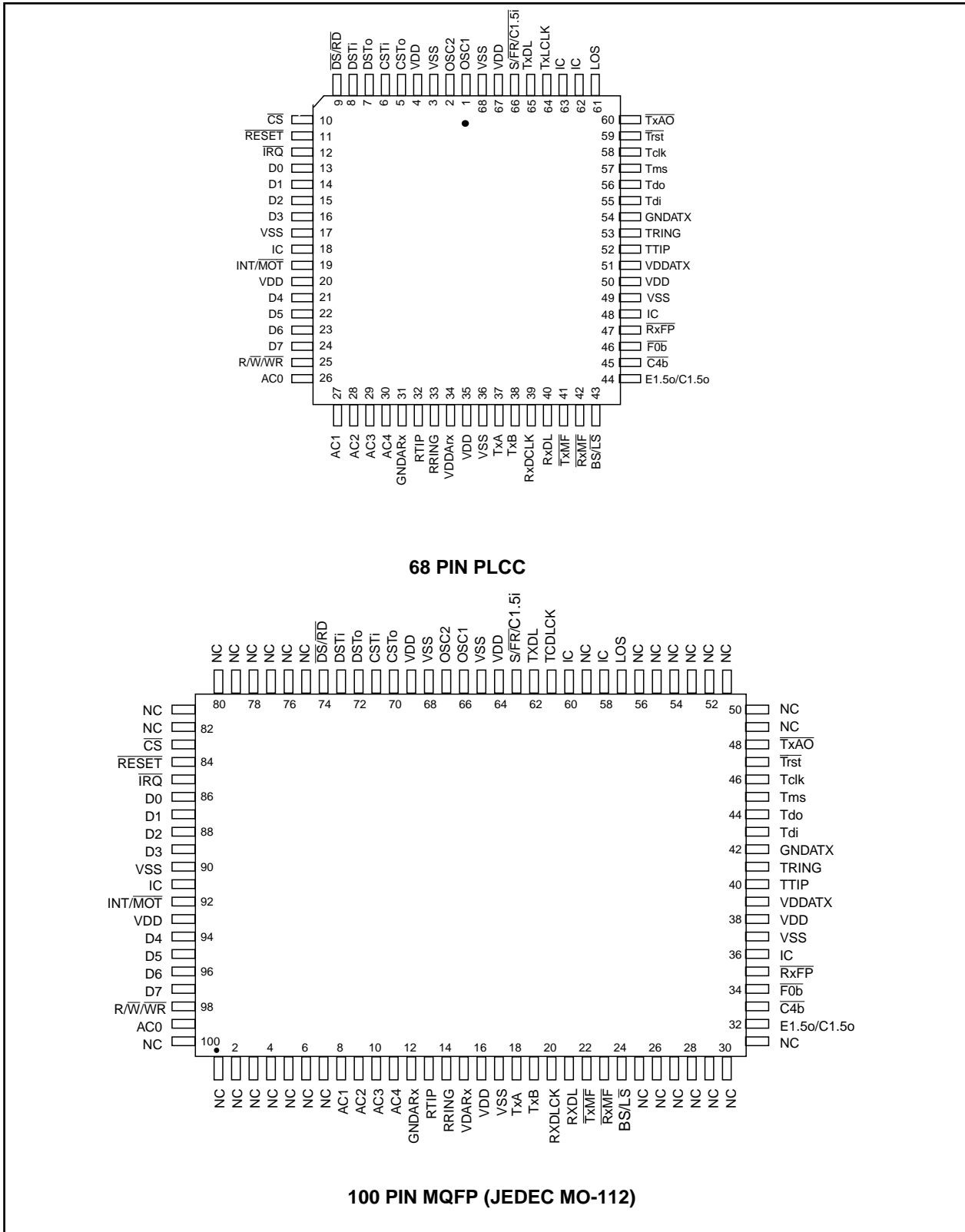

Figure 2 - Pin Connections

## Pin Description

Pin #		Name	Description
68 Pin PLCC	100 Pin MQFP		
1	66	OSC1	<b>Oscillator Input.</b> This pin is either connected via a 20.000 MHz crystal to OSC2 where a crystal is used, or is directly driven when a 20.000 MHz. oscillator is employed.
2	67	OSC2	<b>Oscillator Output.</b> Connect a 20.0 MHz crystal between OSC1 and OSC2. Not suitable for driving other devices.
3	68	V <sub>SS</sub>	<b>Negative Power Supply (Input).</b> Digital ground.
4	69	V <sub>DD</sub>	<b>Positive Power Supply (Input).</b> Digital supply (+5V ± 5%).
5	70	CSTo	<b>Control ST-BUS Output.</b> CSTo carries serial streams for CAS and CCS respectively a 2.048 Mbit/s ST-BUS status stream which contains the 30 receive signalling nibbles (ABCDZZZZ or ZZZZABCD). The most significant nibbles of each ST-BUS time slot are valid and the least significant nibbles of each ST-BUS time slot are tristated when control bit MSN (page 01H, address 1AH, bit 1) is set to 1. If MSN=0, the position of the valid and tristated nibbles are reversed.
6	71	CSTi	<b>Control ST-BUS Input.</b> CSTi carries serial streams for CAS and CCS respectively a 2.048 Mbit/s ST-BUS control stream which contains the 30 transmit signalling nibbles (ABCDXXXX or XXXXABCD) when RPSIG=0. When RPSIG=1 this pin has no function. The most significant nibbles of each ST-BUS time slot are valid and the least significant nibbles of each ST-BUS time slot are ignored when control bit MSN (page 01H, address 1AH, bit 1) is set to 1. If MSN=0, the position of the valid and ignored nibbles is reversed.
7	72	DSTo	<b>Data ST-BUS Output.</b> A 2.048 Mbit/s serial stream which contains the 24/30 PCM(T1/E1) or data channels received on the PCM 24/30 (T1/E1) line.
8	73	DSTi	<b>Data ST-BUS Input.</b> A 2.048 Mbit/s serial stream which contains the 24/30 (T1/E1)PCM or data channels to be transmitted on the PCM 24/30 (T1/E1)line.
9	74	$\overline{DS}/\overline{RD}$	<b>Data/Read Strobe (Input).</b> In Motorola mode ( $\overline{DS}$ ), this input is the active low data strobe of the microprocessor interface. In Intel mode ( $\overline{RD}$ ), this input is the active low read strobe of the microprocessor interface.
10	83	$\overline{CS}$	<b>Chip Select (Input).</b> This active low input enables the non-multiplexed parallel microprocessor interface of the MT9074. When $\overline{CS}$ is set to high, the microprocessor interface is idle and all bus I/O pins will be in a high impedance state.
11	84	$\overline{RESET}$	<b>RESET (Input).</b> This active low input puts the MT9074 in a reset condition. $\overline{RESET}$ should be set to high for normal operation. The MT9074 should be reset after power-up. The $\overline{RESET}$ pin must be held low for a minimum of 1µsec. to reset the device properly.
12	85	$\overline{IRQ}$	<b>Interrupt Request (Output).</b> A low on this output pin indicates that an interrupt request is presented. $\overline{IRQ}$ is an open drain output that should be connected to V <sub>DD</sub> through a pull-up resistor. An active low $\overline{CS}$ signal is not required for this pin to function.
13 - 16	86-89	D0 - D3	<b>Data 0 to Data 3 (Three-state I/O).</b> These signals combined with D4-D7 form the bidirectional data bus of the microprocessor interface (D0 is the least significant bit).

Pin Description

Pin #		Name	Description
68 Pin PLCC	100 Pin MQFP		
17	90	Vss	<b>Negative Power Supply (Input).</b> Digital ground.
18	91	IC	<b>Internal Connection.</b> Tie to Vss (ground) for normal operation.
19	92	INT/MOT	<b>Intel/Motorola Mode Selection (Input).</b> A high on this pin configures the processor interface for the Intel parallel non-multiplexed bus type. A low configures the processor interface for the Motorola parallel non-multiplexed type.
20	93	VDD	<b>Positive Power Supply (Input).</b> Digital supply (+5V± 5%).
21 - 24	94-97	D4 - D7	<b>Data 4 to Data 7 (Three-state I/O).</b> These signals combined with D0-D3 form the bidirectional data bus of the parallel processor interface (D7 is the most significant bit).
25	98	R/W/WR	<b>Read/Write/Write Strobe (Input).</b> In Motorola mode (R/W), this input controls the direction of the data bus D[0:7] during a microprocessor access. When R/W is high, the parallel processor is reading data from the MT9074. When low, the parallel processor is writing data to the MT9074. For Intel mode (WR), this active low write strobe configures the data bus lines as output.
26 - 30	99, 8-11	AC0 - AC4	<b>Address/Control 0 to 4 (Inputs).</b> Address and control inputs for the non-multiplexed parallel processor interface. AC0 is the least significant input.
31	12	GND <sub>ARx</sub>	<b>Receive Analog Ground (Input).</b> Analog ground for the LIU receiver.
32 33	13 14	RTIP RRING	<b>Receive TIP and RING (Input).</b> Differential inputs for the receive line signal - must be transformer coupled (See Figure 5). In digital framer mode these are TTL level inputs that connect to the digital outputs of a receiver. If the receiver serial data output is NRZ connect that output to RTIP. If the receiver data output is split phase unipolar signal connect one signal to RTIP and the complementary signal to RRING.
34	15	VDD <sub>ARx</sub>	<b>Receive Analog Power Supply (Input).</b> Analog supply for the LIU receiver (+5V ± 5%).
35	16	VDD	<b>Positive Power Supply (Input).</b> Digital supply (+5V ± 5%).
36	17	VSS	<b>Negative Power Supply (Input).</b> Digital ground.
37	18	TxA	<b>Transmit A (Output).</b> When the internal LIU is disabled (digital framer only mode), if control bit NRZ=1, and NRZ output data is clocked out on pin TxA with the rising edge of C1.50 (TxB has no function when NRZ format is selected). If NRZ=0, pins TxA and TxB are a complementary pair of signals that output digital dual-rail clocked out with the rising edge of C1.50.
38	19	TxB	<b>Transmit B (Output).</b> When the internal LIU is disabled and control bit NRZ=0, pins TxA and TxB are a complementary pair of signals that output digital dual-rail data clocked out with the rising edge of C1.50.
39	20	RxDLCLK	<b>Data Link Clock (Output).</b> A gapped clock signal derived from the extracted clock from the line clock, available for an external device to clock in RxDL data (at 4, 8, 12, 16 or 20 kHz) on the rising edge.
40	21	RxDL	<b>Receive Data Link (Output).</b> A serial bit stream containing received line data after zero code suppression. This data is clocked out with the rising edge of E1.50.
41	22	TxMF	<b>Transmit Multiframe Boundary (Input).</b> An active low input used to set the transmit multiframe boundary (CAS or CRC multiframe). The MT9074 will generate its own multiframe if this pin is held high. This input is usually pulled high for most applications.

## Pin Description

Pin #		Name	Description
68 Pin PLCC	100 Pin MQFP		
42	23	$\overline{\text{RxMF}}$	<b>Receive Multiframe Boundary (Output).</b> An output pulse delimiting the received multiframe boundary. The next frame output on the data stream (DSTo) is basic frame zero on the T1 or PCM 30 link. In E1 mode this receive multiframe signal can be related to either the receive CRC multiframe (page 01H, address 17H, bit 6, MFSEL=1) or the receive signalling multiframe (MFSEL=0).
43	24	$\text{BS}/\overline{\text{LS}}$	<b>Bus/Line Synchronization Mode Selection (Input).</b> If high, $\overline{\text{C4b}}$ and $\overline{\text{F0b}}$ will be inputs; if low, $\overline{\text{C4b}}$ and $\overline{\text{F0b}}$ will be outputs.
44	32	E1.5o/C1.5o	<b>2.048 MHz in E1 mode or 1.544MHz in T1 mode, Extracted Clock (Output).</b> If the internal L/U is enabled, this output is the clock extracted from the received signal and used internally to clock in data received on RTIP and RRING. If the internal LIU is disabled (digital framer mode), this output is a 1.544MHz clock (T1) C1.5o or a 2.048 MHz clock C2o which clocks out the transmit digital data TXA, TXB.
45	33	$\overline{\text{C4b}}$	<b>4.096 MHz System Clock (Input/Output).</b> $\overline{\text{C4b}}$ is the clock for the ST-BUS sections and transmit serial PCM data of the MT9074. In the free-run (S/ $\overline{\text{FR}}$ =0) or line synchronous mode (S/ $\overline{\text{FR}}$ =1 and BS/ $\overline{\text{LS}}$ =0) this signal is an output, while in bus synchronous mode (S/ $\overline{\text{FR}}$ =1) this signal is an input clock which is phase-locked to the extracted clock (E1.5o).
46	34	$\overline{\text{F0b}}$	<b>Frame Pulse (Input/Output).</b> This is the ST-BUS frame synchronization signal, which delimits the 32 channel frame of CSTi, CSTo, DSTi, DSTo and the PCM30 link. In the free-run (S/ $\overline{\text{FR}}$ =0) or line synchronous mode (S/ $\overline{\text{FR}}$ =1 and BS/ $\overline{\text{LS}}$ =0) this signal is an output, while in the line synchronous mode (S/ $\overline{\text{FR}}$ =1 and BS/ $\overline{\text{LS}}$ =0) this signal is an input.
47	35	$\overline{\text{RxFP}}$	<b>Receive Frame Pulse (Output).</b> An 8kHz pulse signal, which is low for one extracted clock period. This signal is synchronized to the receive DS1 or PCM 30 basic frame boundary.
48	36	IC	<b>Internal Connection.</b> Must be left open for normal operation.
49	37	V <sub>SS</sub>	<b>Negative Power Supply (Input).</b> Digital ground.
50	38	V <sub>DD</sub>	<b>Positive Power Supply (Input).</b> Digital supply (+5V ± 5%).
51	39	V <sub>DD</sub> <sub>ATx</sub>	<b>Transmit Analog Power Supply (Input).</b> Analog supply for the LIU transmitter (+5V ± 5% 10%).
52 53	40 41	TTIP TRING	<b>Transmit TIP and RING (Outputs).</b> Differential outputs for the transmit DS1 line signal - must be transformer coupled (See Figure 5).
54	42	GND <sub>ATx</sub>	<b>Transmit Analog Ground (Input).</b> Analog ground for the LIU transmitter.
55	43	Tdi	<b>IEEE 1149.1 Test Data Input.</b> If not used, this pin should be pulled high.
56	44	Tdo	<b>IEEE 1149.1 Test Data Output.</b> If not used, this pin should be left unconnected.
57	45	Tms	<b>IEEE 1149.1 Test Mode Selection (Input).</b> If not used, this pin should be pulled high.
58	46	Tclk	<b>IEEE 1149.1 Test Clock Signal (Input).</b> If not used, this pin should be pulled high.
59	47	$\overline{\text{Trst}}$	<b>IEEE 1149.1 Reset Signal (Input).</b> If not used, this pin should be held low.
60	48	$\overline{\text{TxAO}}$	<b>Transmit All Ones (Input).</b> High - TTIP, TRING will transmit data normally. Low - TTIP, TRING will transmit an all ones signal.

Pin Description

Pin #		Name	Description
68 Pin PLCC	100 Pin MQFP		
61	57	LOS	<b>Loss of signal or synchronization (Output).</b> When high, and LOS/LOF (page 02H address 13H bit 2) is zero, this signal indicates that the receive portion of the MT9074 is either not detecting an incoming signal (bit LLOS on page 03H address 18H is one) or is detecting a loss of basic frame alignment condition (bit SYNC on page 03H address 10H is one). If LOS/LOF=1, a high on this pin indicates a loss of signal condition.
62	58	IC	<b>Internal Connection.</b> Tie to V <sub>SS</sub> (Ground) for normal operation.
	59	NC	<b>No Connection.</b> Leave open for normal operation.
63	60	IC	<b>Internal Connection.</b> Tie to V <sub>SS</sub> (Ground) for normal operation.
64	61	TxDLCLK	<b>Transmit Data Link Clock (Output).</b> A gapped clock signal derived from a gated 2.048 Mbit/s clock for transmit data link at 4, 8, 12, 16 or 20 kHz. The transmit data link data (TxDL) is clocked in on the rising edge of TxDLCLK. TxDLCLK can also be used to clock DL data out of an external serial controller.
65	62	TxDL	<b>Transmit Data Link (Input).</b> An input serial stream of transmit data link data at 4, 8, 12, 16 or 20 kbit/s.
66	63	S/FR/C1.5i	<b>Synchronous/Freerun Extracted Clock (Input):</b> If low, and the internal LIU is enabled, the MT9074 is in free run mode. Pins 45 C4b and 46 F0b are outputs generating system clocks. Slips will occur in the receive slip buffer as a result of any deviation between the MT9074's internal PLL (which is free - running) and the frequency of the incoming line data. If high, and the internal LIU is enabled, the MT9074 is in Bus or Line Synchronization mode depending on the BS/LS pin. If the internal LIU is disabled, in digital framer mode, this pin (C1.5i) takes an input clock 1.544Mhz (T1) / 2.048Mhz (E1) that clocks in the received digital data on pins RTIP and RRING with its rising edge.
67	64	VDD	<b>Positive Power Supply (Input).</b> Digital supply (+5V ± 5%).
68	65	VSS	<b>Negative Power Supply (Input).</b> Digital ground.

Device Overview

The MT9074 in T1 mode operates as an advanced T1 framer with an on-chip Line Interface Unit (LIU) that meets or supports the recommendations including ITU I.431, AT&T PUB43801, TR-62411, ANSI T1.102, T.403 and T.408.

The MT9074 in E1 mode operates as an advanced PCM 30 framer with an on-chip Line Interface Unit (LIU) that meets or supports the latest ITU-T Recommendations for PCM 30 and ISDN primary rate including G.703, G.704, G.706, G.775, G.796, G.732, G.823 and I.431. It also meets or supports the layer 1 requirements of ETSI ETS 300 011, ETS 300 166, ETS 300 233 and BS6450.

The Line Interface Unit (LIU) of the MT9074 interfaces the digital framer functions to either the

DS1 (T1 mode) or PCM 30 (E1 mode) transformer-isolated four wire line. The transmit portion of the MT9074 LIU consists of a digital buffer, a digital-to-analog converter, and a differential line driver. The receiver portion of the MT9074 LIU consists of an input signal peak detector, an optional equalizer, a smoothing filter, data and clock slicers and a clock extractor.

System timing may be slaved to the line, operated in free-run mode or controlled by an external timing source. In T1 mode the MT9074 contains a PLL which always generates the transmit timing for the LIU. In E1 mode the LIU also contains a Jitter Attenuator (JA), which can be included in either the transmit or receive path. The MT9074 will attenuate jitter from 2.5 Hz and roll-off at a rate of 20 dB/decade. The intrinsic jitter is less than 0.02 UI. The PLL output (@1.544 MHz for T1 mode and @2.048 MHz for E1 mode) clocks out the transmit line data.



To accommodate some special applications, the MT9074 also supports a digital framer only mode by providing direct access to the transmit and receive data in digital format, i.e. by-passing the analog LIU front-end.

The digital portion of the MT9074 connects selected channels of an incoming stream of time multiplexed 2.048 Mbit/s PCM channels to the transmit payload of either the T1 or E1 trunk, while the receive payload is connected to the ST-BUS 2.048 Mbit/s backplane bus for both data and signalling with channel times and the frame boundary synchronous to the transmit side. Control, reporting and conditioning of the line is implemented via a parallel microprocessor interface.

The MT9074 has a comprehensive suite of status, alarm, performance monitoring and reporting features. These include counters for BPVs, CRC errors, F-bit errors (T1 only), E-bit errors (E1 only), errored frame alignment signals (E1 only), BERT, OOF (T1 only), and RAI and continuous CRC errors (E1 only). Also, included are transmission error insertion for BPVs, CRC-6 errors (T1 only), CRC-4 errors (E1 only), framing bit errors (T1 only), frame and non-frame alignment signal errors (E1 only), payload errors and loss of signal errors. A built-in PRBS generator ( $2^{15} - 1$ ) can be connected to any combination of outgoing channels; an equivalent PRBS error detector can be independently connected to any combination of receive channels.

A complete set of loopbacks has been implemented, which include digital, remote, ST-BUS, payload, local, metallic and remote time slot.

The MT9074 also provides a comprehensive set of maskable interrupts. Interrupt sources consist of synchronization status, alarm status, counter indication and overflow, timer status, slip indication, maintenance functions and receive channel associated signaling bit changes.

In T1 mode the framer operates in any one of the framing modes: D4, SLC-96 and Extended Superframe (ESF). The ESF FDL bits of the MT9074 can be accessed either through the data link pins TxDL, RxDL, RxDLCLK and TxDLCLK, or through internal registers for Bit Oriented Messages, or through a built-in HDLC. A second HDLC may be connected to DS1 channel 24 for the ISDN Primary Rate signaling applications.

In E1 mode the MT9074 operates in either termination or transparent modes selectable via software control. In the termination mode the CRC-4

calculation is performed as part of the framing algorithm. In the transmit transparent mode, no framing or signalling is imposed on the data transmit from DSTi on the line. In addition, the MT9074 optionally allows the data link maintenance channel to be modified and updates the CRC-4 remainder bits to reflect the modification. All channel, framing and signalling data passes through the device unaltered. This is useful for intermediate point applications of a PCM 30 link where the data link data is modified, but the error information transported by the CRC-4 bits must be passed to the terminating end. In the receive transparent mode, the received line data is channelled to DSTo with framing operations disabled, consequently, the data passes through the slip buffer and drives DSTo with an arbitrary alignment.

In E1 mode the  $S_a$  bits can be accessed by the MT9074 in the following three ways:

- Programming a register;
- Data link pins TxDL, RxDL, RxDLCLK and TxDLCLK;
- HDLC Controller with a 128 byte FIFO.

A second HDLC Controller with a 128 byte FIFO is available for connection to timeslot 16 in E1 mode.

## Functional Description

### MT9074 Line Interface Unit (LIU)

#### Receiver

The receiver portion of the MT9074 LIU consists of an input signal peak detector, an optional equalizer with two separate high pass sections, a smoothing filter, data and clock slicers and a clock extractor. Receive equalization gain can be set manually (i.e., software) or it can be determined automatically by peak detectors.

The output of the receive equalizer is conditioned by a smoothing filter and is passed on to the clock and data slicer. The clock slicer output signal drives a phase locked loop, which generates an extracted clock (C1.50). This extracted clock is used to sample the output of the data comparator

In T1 mode, the receiver portion of the LIU can reliably recover clock and data from signals attenuated by up to 36 dB @ 772 kHz (translates to 6000 ft. of PIC 24 AWG cable) and tolerate jitter to the maximum specified by AT&T TR 62411 (see Figure 3).

In E1 mode the receiver portion of the LIU can reliably recover clock and data from signals

attenuated by up to 36 dB @ 1024 kHz (translates to 2000 m. of PIC 0.65mm or 22 AWG cable) and tolerate jitter to the maximum specified by ETS 300 011 (Figure 4).

The LOS output pin function is user selectable to indicate any combination of loss of signal and/or loss of basic frame synchronization condition.

The LLOS (Loss of Signal) status bit indicates when the receive signal level is lower than the analog threshold for at least 1 millisecond, or when more than 192 consecutive zeros have been received. In E1 mode the analog threshold is either of -20 dB or -40 dB. For T1 mode the analog threshold is -40 dB.

In T1 mode, the receive LIU circuit requires a terminating resistor of 100Ω across the device side of the receive 1:1 transformer.

In E1 mode the receive LIU circuit requires a terminating resistor of either 120Ω or 75Ω across the device side of the receive 1:1 transformer.

The jitter tolerance of the clock extractor circuit exceeds the requirements of TR 62411 in T1 mode (see Figure 3) and G.823 in E1 mode (see Figure 4).

Transmitter

The transmit portion of the MT9074 LIU consists of a high speed digital-to-analog converter and complementary line drivers.

When a pulse is to be transmitted, a sequence of digital values (dependent on transmit equalization) are read out of a ROM by a high speed clock. These values drive the digital-to-analog converter to

produce an analog signal, which is passed to the complementary line drivers.

The complementary line drivers are designed to drive a 1:2 step-up transformer (see Figure 5 for T1 mode and Figure 6 for E1 mode). A 0.68 uF capacitor is required between the TTIP and the transmit transformer. Resistors RT (as shown in Figure 5) are for termination for transmit return loss. The values of RT may be optimized for T1 mode, E1 120Ω lines, E1 75Ω lines or set at a compromise value to serve multiple applications. Program the LIU Control Word (address 1FH page 1) to adjust the pulse amplitude accordingly.

Alternatively, the pulse level and shape may be discretely programmed by writing to the Custom Pulse Level registers (addresses 1CH to 1FH, page 2) and setting the Custom Transmit Pulse bit high (bit 3 of the Transmit Pulse Control Word). In this case the output of each of the registers directly drives the D/A converter going to the line driver. Tables 1 and 2 show recommended transmit pulse amplitude settings.

In T1 mode, the template for the transmitted pulse (the DSX-1 template) is shown in Figure 7. The nominal peak voltage of a mark is 3 volts. The ratio of the amplitude of the transmit pulses generated by TTIP and TRING lie between 0.95 and 1.05.

In E1 mode, the template for the transmitted pulse, as specified in G.703, is shown in Figure 8. The nominal peak voltage of a mark is 3 volts for 120 Ω twisted pair applications and 2.37 volts for 75 Ω coax applications. The ratio of the amplitude of the transmit pulses generated by TTIP and TRING lie between 0.95 and 1.05.

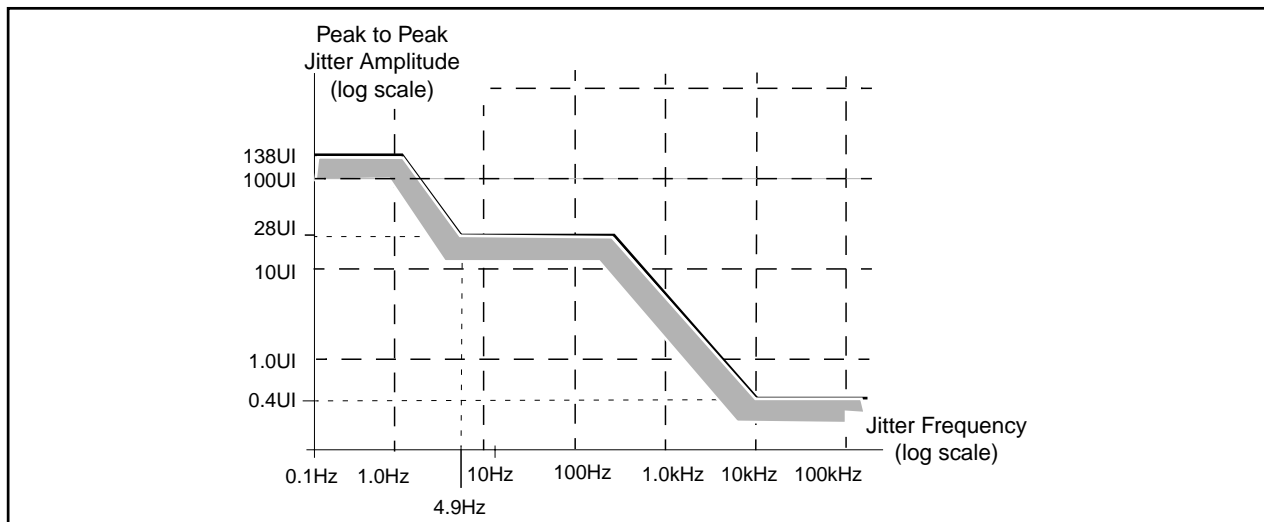

Figure 3 - Input Jitter Tolerance as Recommended by TR-62411 (T1)



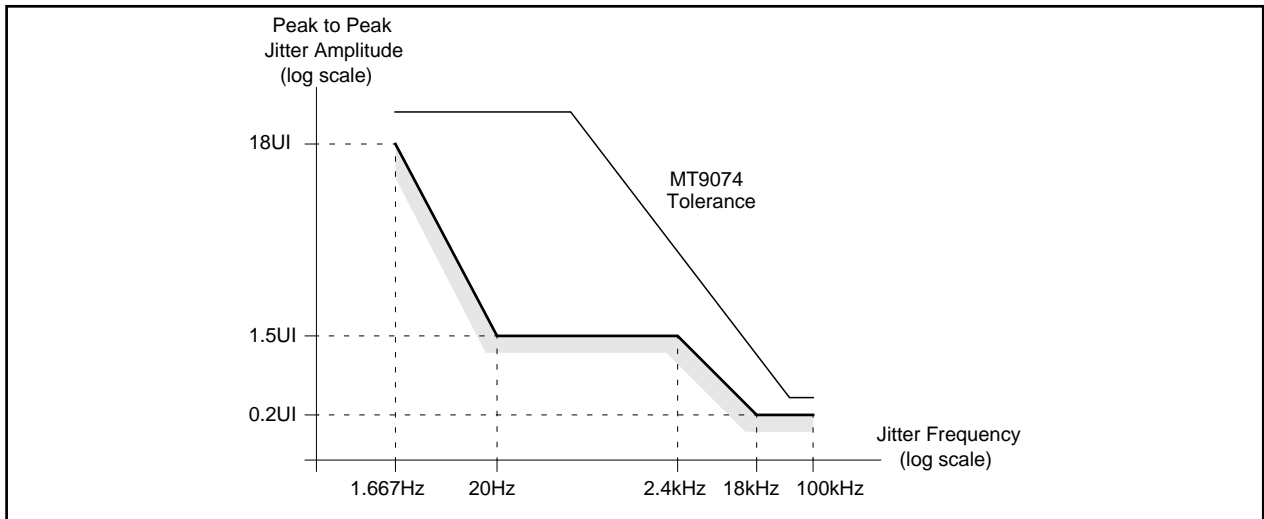

Figure 4 - Input Jitter Tolerance as recommended by ETSI 300 011 (E1)

Name	Functional Description																																				
TXL2-0	<p><b>Transmit Line Build Out 2 - 0.</b> Setting these bits shapes the transmit pulse as detailed in the table below:</p> <table border="1"> <thead> <tr> <th>TXL2</th> <th>TXL1</th> <th>TXL0</th> <th>Line Build Out</th> </tr> </thead> <tbody> <tr> <td>0</td> <td>0</td> <td>0</td> <td>0 to 133 feet/ 0 dB</td> </tr> <tr> <td>0</td> <td>0</td> <td>1</td> <td>133 to 266 feet</td> </tr> <tr> <td>0</td> <td>1</td> <td>0</td> <td>266 to 399 feet</td> </tr> <tr> <td>0</td> <td>1</td> <td>1</td> <td>399 to 533 feet</td> </tr> <tr> <td>1</td> <td>0</td> <td>0</td> <td>533 to 655 feet</td> </tr> <tr> <td>1</td> <td>0</td> <td>1</td> <td>-7.5 dB</td> </tr> <tr> <td>1</td> <td>1</td> <td>0</td> <td>-15 dB</td> </tr> <tr> <td>1</td> <td>1</td> <td>1</td> <td>-22.5 dB</td> </tr> </tbody> </table> <p>After reset these bits are zero.</p>	TXL2	TXL1	TXL0	Line Build Out	0	0	0	0 to 133 feet/ 0 dB	0	0	1	133 to 266 feet	0	1	0	266 to 399 feet	0	1	1	399 to 533 feet	1	0	0	533 to 655 feet	1	0	1	-7.5 dB	1	1	0	-15 dB	1	1	1	-22.5 dB
TXL2	TXL1	TXL0	Line Build Out																																		
0	0	0	0 to 133 feet/ 0 dB																																		
0	0	1	133 to 266 feet																																		
0	1	0	266 to 399 feet																																		
0	1	1	399 to 533 feet																																		
1	0	0	533 to 655 feet																																		
1	0	1	-7.5 dB																																		
1	1	0	-15 dB																																		
1	1	1	-22.5 dB																																		

Table 1 - Transmit Line Build Out (T1)

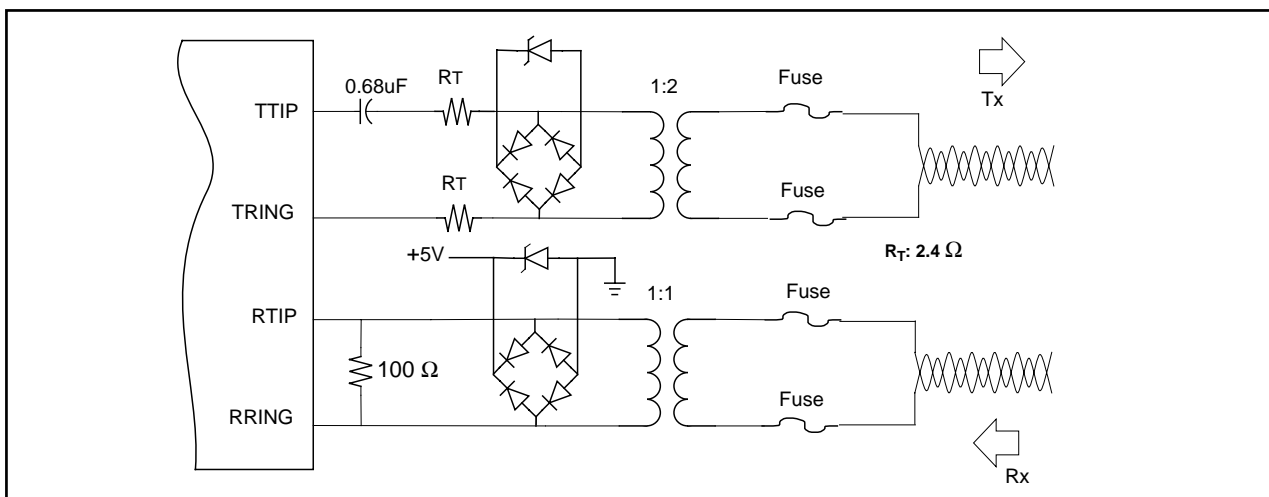

Figure 5 - Analog Line Interface (T1)

Name	Functional Description																																																						
TX2-0	<p><b>Transmit pulse amplitude.</b> Select the TX2 –TX0 bits according to the line type, value of termination resistors (RT), and transformer turns ratio used</p> <table border="1"> <thead> <tr> <th>TX2</th> <th>TX1</th> <th>TX0</th> <th>Line Impedance(<math>\Omega</math>)</th> <th>RT(<math>\Omega</math>)</th> <th>Transformer Ratio</th> </tr> </thead> <tbody> <tr> <td>0</td> <td>0</td> <td>0</td> <td>120</td> <td>0</td> <td>1:2</td> </tr> <tr> <td>0</td> <td>0</td> <td>1</td> <td>120</td> <td>0</td> <td>1:1</td> </tr> <tr> <td>0</td> <td>1</td> <td>0</td> <td>120</td> <td>15</td> <td>1:2</td> </tr> <tr> <td>0</td> <td>1</td> <td>1</td> <td>120 / 75</td> <td>12.1</td> <td>1:2</td> </tr> <tr> <td>1</td> <td>0</td> <td>0</td> <td>75</td> <td>0</td> <td>1:2</td> </tr> <tr> <td>1</td> <td>0</td> <td>1</td> <td>75</td> <td>0</td> <td>1:1</td> </tr> <tr> <td>1</td> <td>1</td> <td>1</td> <td>75</td> <td>9.1</td> <td>1:2</td> </tr> <tr> <td>1</td> <td>1</td> <td>1</td> <td>75 / 120</td> <td>12.1</td> <td>1:2</td> </tr> </tbody> </table> <p>After reset these bits are zero.</p>	TX2	TX1	TX0	Line Impedance( $\Omega$ )	RT( $\Omega$ )	Transformer Ratio	0	0	0	120	0	1:2	0	0	1	120	0	1:1	0	1	0	120	15	1:2	0	1	1	120 / 75	12.1	1:2	1	0	0	75	0	1:2	1	0	1	75	0	1:1	1	1	1	75	9.1	1:2	1	1	1	75 / 120	12.1	1:2
TX2	TX1	TX0	Line Impedance( $\Omega$ )	RT( $\Omega$ )	Transformer Ratio																																																		
0	0	0	120	0	1:2																																																		
0	0	1	120	0	1:1																																																		
0	1	0	120	15	1:2																																																		
0	1	1	120 / 75	12.1	1:2																																																		
1	0	0	75	0	1:2																																																		
1	0	1	75	0	1:1																																																		
1	1	1	75	9.1	1:2																																																		
1	1	1	75 / 120	12.1	1:2																																																		

Table 2 -Transmit Pulse Amplitude (E1)

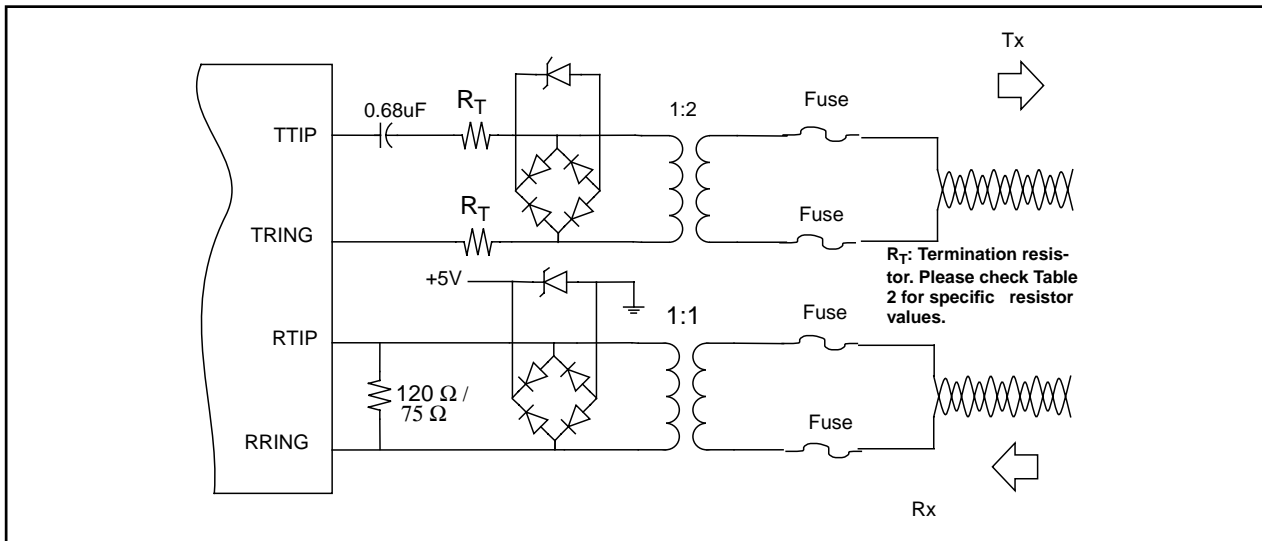

Figure 6 - Analog Line Interface (E1)

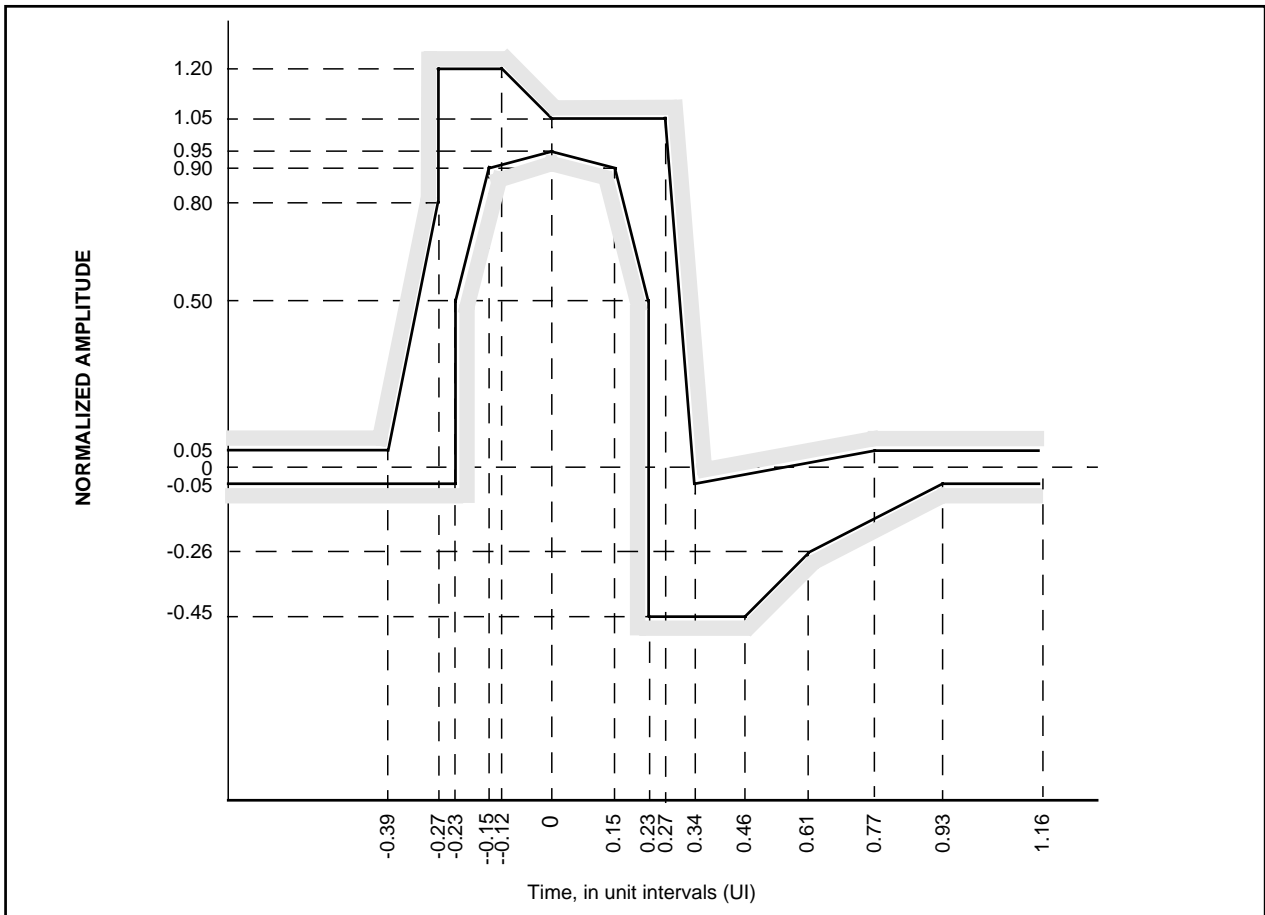

Figure 7 - Pulse Template (T1.403) (T1)

<b>Time (Nanoseconds)</b>	-499	-253	-175	-175	-78	0	175	220	499	752	---	---
<b>Time U.I.</b>	-.77	-.39	-.27	-.27	-.12	0	.27	.34	.77	1.16	---	---
<b>Normalized Amplitude</b>	.05	.05	.8	1.2	1.2	1.05	1.05	-.05	.05	.05	---	---

Table 3 - Maximum Curve for Figure 7

<b>Time (Nanoseconds)</b>	-499	-149	-149	-97	0	97	149	149	298	395	603	752
<b>Time U.I.</b>	-.77	-.23	-.23	-.15	0	.15	.23	.23	.46	.61	.93	1.16
<b>Normalized Amplitude</b>	-.05	-.05	.5	.9	.95	.9	.5	-.45	-.45	-.26	-.05	-.05

Table 4 - Minimum curve for Figure 7

Note: One Unit Interval = 648 nanoseconds

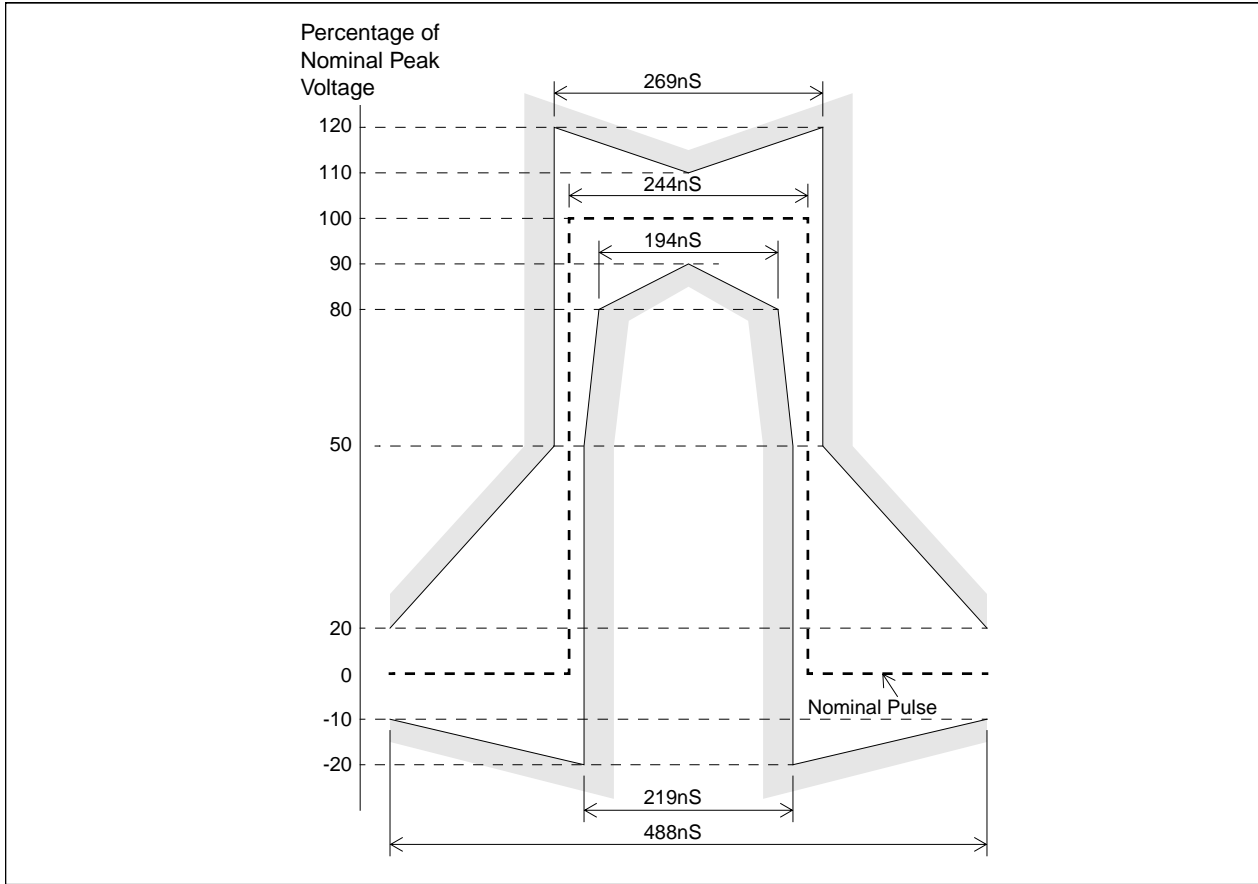

Figure 8 Pulse Template (G.703)(E1)

**20 Mhz Clock**

The MT9074 requires a 20 Mhz clock. This may be provided by a 50 ppm oscillator as per Figure 9.

<i>Frequency:</i>	20MHz
<i>Tolerance:</i>	50ppm
<i>Oscillation Mode:</i>	Fundamental
<i>Resonance Mode:</i>	Parallel
<i>Load Capacitance:</i>	32pF
<i>Maximum Series Resistance:</i>	35Ω
<i>Approximate Drive Level:</i>	1mW

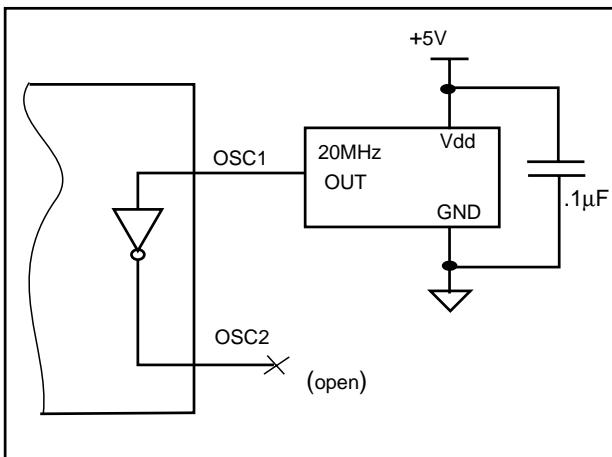

Figure 9 - Clock Oscillator Circuit

Alternatively, a crystal oscillator may be used. A complete oscillator circuit made up of a crystal, resistors and capacitors is shown in Figure 10. The crystal specification is as follows.

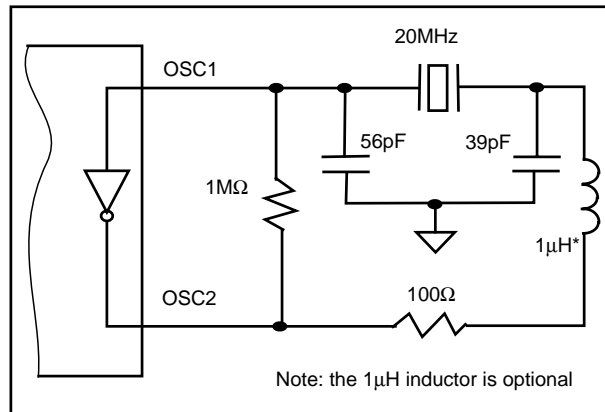

Figure 10 - Crystal Oscillator Circuit

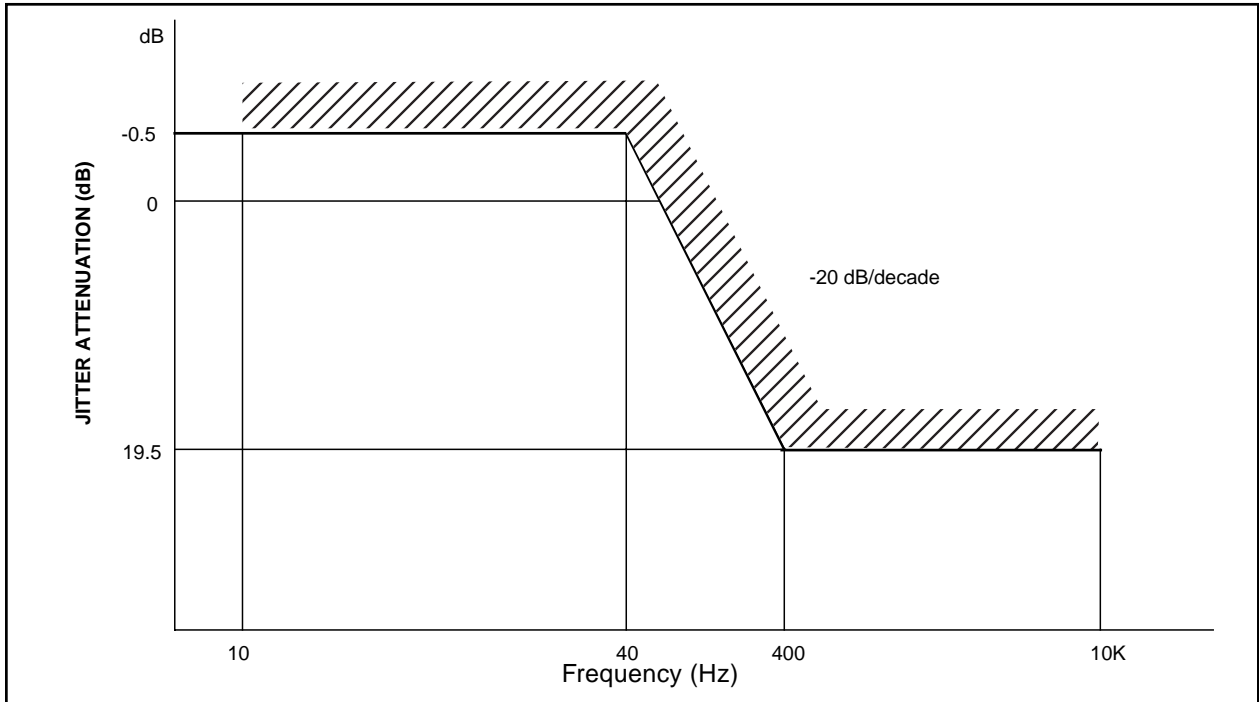

Figure 11- TR 62411 Jitter Attenuation Curve

**Phase Lock Loop (PLL)**

The MT9074 contains a PLL, which can be locked to either an input 4.096 Mhz clock or the extracted line clock. The PLL will attenuate jitter from less than 2.5 Hz and roll-off at a rate of 20 dB/decade. Its intrinsic jitter is less than 0.02 UI. The PLL will meet the jitter transfer characteristics as specified by ATT document TR 62411 and the relevant recommendations as shown in Figure 11.

**Clock Jitter Attenuation Modes**

MT9074 has three basic jitter attenuation modes of operation, selected by the BS/LS and S/FR control pins. Referring to the mode names given in Table 5 the basic operation of the jitter attenuation modes are:

- System Bus Synchronous Mode.
- Line Synchronous Mode.
- Free-run mode.

In System Bus Synchronous mode pins C4b and F0b are always configured as inputs, while in the Line Synchronous and Free-Run modes C4b and F0b are configured as outputs.

In System Bus Synchronous mode an external clock is applied to C4b. The applied clock is dejittered by

Mode Name	BS/LS	S/FR	Note
System Bus Synchronous	1	1	PLL locked to C4b.
Line Synchronous	0	1	PLL locked to E1.5o.
Free-Run	x	0	PLL free - running.

Table 5 - Selection of clock jitter attenuation modes using the M/S and MS/FR pins

the internal PLL before being used to synchronize the transmitted data. The clock extracted (with no jitter attenuation performed) from the receive data can be monitored on pin E1.5o.

In Line Synchronous mode, the clock extracted from the receive data is dejittered using the internal PLL and then output on pin C4b. Pin E1.5o provides the extracted receive clock before it has been dejittered. The transmit data is synchronous to the clean receive clock.

In Free-Run mode the transmit data is synchronized to the internally generated clock. The internal clock is output on pin C4b. The clock signal extracted from the receive data is not dejittered and is output directly on E1.5o.

Depending on the mode selection above, the PLL can either attenuate transmit clock jitter or the receive clock jitter. Table 5 shows the appropriate configuration of each control pin to achieve the

appropriate mode and Jitter attenuation capability of the MT9074

**The Digital Interface**

**T1 Digital Interface**

In T1 mode DS1 frames are 193 bits long and are transmitted at a frame repetition rate of 8000 Hz, which results in an aggregate bit rate of 193 bits x 8000/sec= 1.544 Mbits/sec. The actual bit rate is 1.544 Mbits/sec +/-50 ppm optionally encoded in B8ZS format. The Zero Suppression control register (page 1, address 15H,) selects either B8ZS encoding, forced one stuffing or alternate mark inversion (AMI) encoding. Basic frames are divided into 24 time slots numbered 1 to 24. Each time slot is 8 bits in length and is transmitted most significant bit first (numbered bit 1). This results in a single time slot data rate of 8 bits x 8000/sec. = 64 kbits/sec.

It should be noted that the Mitel ST-BUS has 32 channels numbered 0 to 31. When mapping to the DS1 payload only the first 24 time slots and the last (time slot 31, for the overhead bit) of an ST-BUS are used (see Table 6). All unused channels are tristate.

When signalling information is written to the MT9074 in T1 mode using ST-BUS control links (as opposed to direct writes by the microport to the on - board signaling registers), the CSTi channels corresponding to the selected DSTi channels streams are used to transmit the signalling bits.

Since the maximum number of signalling bits associated with any channel is 4 (in the case of ABCD), only half a CSTi channel is required for sourcing the signaling bits. The choice of which half of the channel to use is selected by the control bit MSN (page 01H address 14H). The same control bit selects which half of the CSTo channel will contain receive signaling information (the other nibble in the channel being tristate). Unused channels are tristate.

The most significant bit of an eight bit ST-BUS channel is numbered bit 7 (see Mitel Application Note MSAN-126). Therefore, ST-BUS bit 7 is synonymous with DS1 bit 1; bit 6 with bit 2: and so on.

**Frame and Superframe Structure in T1 mode**

Multiframeing

In T1 mode, DS1 trunks contain 24 bytes of serial voice/data channels bundled with an overhead bit. The frame overhead bit contains a fixed repeating pattern used to enable DS1 receivers to delineate frame boundaries. Overhead bits are inserted once per frame at the beginning of the transmit frame boundary. The DS1 frames are further grouped in bundles of frames, generally 12 (for D4 applications) or 24 frames (for ESF - extended superframe applications) deep. Table 7 and 8 illustrate the D4 and ESF frame structures respectively.

For D4 links the frame structure contains an alternating 101010... pattern inserted into every second overhead bit position. These bits are intended for determination of frame boundaries, and they are referred to as Ft bits. A separate fixed pattern, repeating every superframe, is interleaved with the Ft bits. This fixed pattern (001110), is used to delineate the 12 frame superframe. These bits are referred to as the Fs bits. In D4 frames # 6 and #12, the LSB of each channel byte may be replaced with A bit (frame #6) and B bit (frame #12) signalling information.

For ESF links the 6 bit framing pattern 001011, inserted into every 4th overhead bit position, is used to delineate both frame and superframe boundaries. Frames #6, 12, 18 and 24 contain the A, B, C and D signalling bits, respectively. A 4 kHz data link is embedded in the overhead bit position, interleaved between the framing pattern sequence (FPS) and the transmit CRC-6 remainder (from the calculation done on the previous superframe), see Table 8.

DS1 Timeslots	1	2	3	4	5	6	7	8	9	10	11	12	13	14	15	16
Voice/Data Channels (DSTi/o and CSTi/o)	0	1	2	3	4	5	6	7	7	9	10	11	12	13	14	15
Ds1 Timeslots	17	18	19	20	21	22	23	24	-	-	-	-	-	-	-	-
Voice/Data Channels (DSTi/o and CSTi/o)	16	17	18	19	20	21	22	23	24	25	26	27	28	29	30	31 S bit

**Table 6 - STBUS vs. DS1 to Channel Relationship(T1)**



The SLC-96 frame structure is similar to the D4 frame structure, except a facility management overlay is superimposed over the erstwhile Fs bits, see Table 9.

The protocol appropriate for the application is selected via the Framing Mode Selection Word, address 10H of Master Control page 1. In T1 mode MT9074 is capable of generating the overhead bit framing pattern and (for ESF links) the CRC remainder for transmission onto the DS1 trunk. The beginning of the transmit multiframe may be determined by any of the following criteria:

(i) It may free - run with the internal multiframe counters;

(ii) The multiframe counters may be reset with the external hardware pin  $\overline{\text{TxMF}}$ . If this signal is not synchronous with the current transmit frame count it may cause the far end to go temporarily out of sync.

(iii) Under software control (by setting the TxSYNC bit in page 01 address 12H) the transmit multiframe counters will be synchronized to the framing pattern present in the overhead bits multiplexed into channel 31 bit 0 of the incoming 2.048 Mb/s digital stream DSTi. Note that the overhead bits extracted from the receive signal are multiplexed into outgoing DSTo channel 31 bit 0.

(iv) In SLC - 96 mode the transmit frame counters synchronize to the framing pattern clocked in on the TXDL input.

Frame #	Ft	Fs	Signalling
1	1		
2		0	
3	0		
4		0	
5	1		
6		1	A
7	0		
8		1	
9	1		
10		1	
11	0		
12		0	B

Table 7 - D4 Superframe Structure(T1)

Frame #	FPS	FDL	CRC	Signalling
1		X		
2			CB1	
3		X		
4	0			
5		X		
6			CB2	A
7		X		
8	0			
9		X		
10			CB3	
11		X		
12	1			B
13		X		
14			CB4	
15		X		
16	0			
17		X		
18			CB5	C
19		X		
20	1			
21		X		
22			CB6	
23		X		
24	1			D

Table 8 - ESF Superframe Structure (T1)

Frame #	Ft	Fs	Notes	Frame #	Ft	Fs	Notes	Frame #	Ft	Fs	Notes
1	1			25	1		C	49	1		
2		0	R	26		X	o	50		S	S = Spoiler Bits
3	0		e	27	0		n	51	0		
4		0	s	28		X	c	52		S	
5	1		y	29	1		e	53	1		
6		0	n	30		X	n	54		C	C = Maintenance Field Bits
7	0		c	31	0		t	55	0		
8		1	h	32		X	r	56		C	
9	1		r	33	1		a	57	1		
10		1	o	34		X	t	58		C	
11	0		n	35	0		o	59	0		
12		1	i	36		X	r	60		A	A = Alarm Field Bits
13	1		z	37	1			61	1		
14		0	a	38		X	F	62		A	
15	0		t	39	0		i	63	0		
16		0	i	40		X	e	64		L	L = Line Switch Field Bits
17	1		o	41	1		l	65	1		
18		0	n	42		X	d	66		L	
19	0			43	0			67	0		
20		1	d	44		X	B	68		L	
21	1		a	45	1		i	69	1		
22		1	t	46		X	t	70		L	
23	0		a	47	0		s	71	0		
24		1		48		S		72		S	S = Spoiler Bits

Table 9 - SLC-96 Framing Structure(T1)

**E1 Digital Interface**

PCM 30 (E1) basic frames are 256 bits long and are transmitted at a frame repetition rate of 8000 Hz, which results in an aggregate bit rate of 256 bits x 8000/sec = 2.048 Mbits/sec. The actual bit rate is 2.048 Mbits/sec +/-50 ppm encoded in HDB3 format. The HDB3 control bit (page 01H, address 15H, bit 5) selects either HDB3 encoding or alternate mark inversion (AMI) encoding. Basic frames are divided into 32 time slots numbered 0 to 31, see Figure 34. Each time slot is 8 bits in length and is transmitted most significant bit first (numbered bit 1). This results in a single time slot data rate of 8 bits x 8000/sec. = 64 kbits/sec.

It should be noted that the Mitel ST-BUS also has 32 channels numbered 0 to 31, but the most significant bit of an eight bit channel is numbered bit 7 (see Mitel Application Note MSAN-126). Therefore, ST-BUS bit 7 is synonymous with PCM 30 bit 1; bit 6 with bit 2: and so on (Figure 34).

PCM 30 time slot 0 is reserved for basic frame alignment, CRC-4 multiframe alignment and the communication of maintenance information. In most configurations time slot 16 is reserved for either Channel Associated Signalling (CAS or ABCD bit signalling) or Common Channel Signalling (CCS). The remaining 30 time slots are called channels and carry either PCM encoded voice signals or digital data. Channel alignment and bit numbering is consistent with time slot alignment and bit numbering. However, channels are numbered 1 to 30 and relate to time slots as per Table 10.

PCM 30 Timeslots	0	1,2,3...15	16	17,18,19,... 31
Voice/Data Channels (DSTi/o and CSTi/o)	0	1,2,3...15	16	17,18,19,... 31

Table 10 - STBUS vs. PCM-30 to Channel Relationship(E1)

**Basic Frame Alignment**

Time slot 0 of every basic frame is reserved for basic frame alignment and contains either a Frame Alignment Signal (FAS) or a Non-Frame Alignment Signal (NFAS). FAS and NFAS occur in time slot zero of consecutive basic frames as shown in Table 12. Bit two is used to distinguish between FAS (bit two = 0) and NFAS (bit two = 1).

Basic frame alignment is initiated by a search for the bit sequence 0011011 which appears in the last seven bit positions of the FAS, see the Frame Algorithm section. Bit position one of the FAS can be either a CRC-4 remainder bit or an international usage bit.

Bits four to eight of the NFAS (i.e., Sa4 - Sa8) are additional spare bits which may be used as follows:

- Sa4 to Sa8 may be used in specific point-to-point applications (e.g. transcoder equipments conforming to G.761).
- Sa4 may be used as a message-based data link for operations, maintenance and performance monitoring.
- Sa5 to Sa8 are for national usage.

A maintenance channel or data link at 4,8,12,16, or 20 kHz for selected Sa bits is provided by the MT9074 in E1 mode to implement these functions. Note that for simplicity all Sa bits including Sa4 are collectively called national bits throughout this document.

Bit three (designated as “A”), the Remote Alarm Indication (RAI), is used to indicate the near end basic frame synchronization status to the far end of a link. Under normal operation, the A (RAI) bit should be set to 0, while in alarm condition, it is set to 1.

Bit position one of the NFAS can be either a CRC-4 multiframe alignment signal, an E-bit or an international usage bit. Refer to an approvals laboratory and national standards bodies for specific requirements.

CRC	CRC Frame/Type	PCM 30 Channel Zero							
		1	2	3	4	5	6	7	8
Sub Multi Frame 1	0/FAS	C <sub>1</sub>	0	0	1	1	0	1	1
	1/NFAS	0	1	A	S <sub>a4</sub>	S <sub>a5</sub>	S <sub>a6</sub>	S <sub>a7</sub>	S <sub>a8</sub>
	2/FAS	C <sub>2</sub>	0	0	1	1	0	1	1
	3/NFAS	0	1	A	S <sub>a4</sub>	S <sub>a5</sub>	S <sub>a6</sub>	S <sub>a7</sub>	S <sub>a8</sub>
	4/FAS	C <sub>3</sub>	0	0	1	1	0	1	1
	5/NFAS	1	1	A	S <sub>a4</sub>	S <sub>a5</sub>	S <sub>a6</sub>	S <sub>a7</sub>	S <sub>a8</sub>
	6/FAS	C <sub>4</sub>	0	0	1	1	0	1	1
Sub Multi Frame 2	7/NFAS	0	1	A	S <sub>a4</sub>	S <sub>a5</sub>	S <sub>a6</sub>	S <sub>a7</sub>	S <sub>a8</sub>
	8/FAS	C <sub>1</sub>	0	0	1	1	0	1	1
	9/NFAS	1	1	A	S <sub>a4</sub>	S <sub>a5</sub>	S <sub>a6</sub>	S <sub>a7</sub>	S <sub>a8</sub>
	10/FAS	C <sub>2</sub>	0	0	1	1	0	1	1
	11/NFAS	1	1	A	S <sub>a4</sub>	S <sub>a5</sub>	S <sub>a6</sub>	S <sub>a7</sub>	S <sub>a8</sub>
	12/FAS	C <sub>3</sub>	0	0	1	1	0	1	1
	13/NFAS	E <sub>1</sub>	1	A	S <sub>a4</sub>	S <sub>a5</sub>	S <sub>a6</sub>	S <sub>a7</sub>	S <sub>a8</sub>
14/FAS	C <sub>4</sub>	0	0	1	1	0	1	1	
15/NFAS	E <sub>2</sub>	1	A	S <sub>a4</sub>	S <sub>a5</sub>	S <sub>a6</sub>	S <sub>a7</sub>	S <sub>a8</sub>	

**Table 11 - FAS and NFAS Structure**

 indicates position of CRC-4 multiframe alignment sign:

**CRC-4 Multiframing in E1 mode**

The primary purpose for CRC-4 multiframing is to provide a verification of the current basic frame alignment, although it can also be used for other functions such as bit error rate estimation. The CRC-4 multiframe consists of 16 basic frames numbered 0 to 15, and has a repetition rate of 16 frames X 125 microseconds/frame = 2 msec.

CRC-4 multiframe alignment is based on the 001011 bit sequence, which appears in bit position one of the first six NFASs of a CRC-4 multiframe.

The CRC-4 multiframe is divided into two submultiframes, numbered 1 and 2, which are each eight basic frames or 2048 bits in length.

The CRC-4 frame alignment verification functions as follows. Initially, the CRC-4 operation must be activated and CRC-4 multiframe alignment must be achieved at both ends of the link. At the local end of a link, all the bits of every transmit submultiframe are passed through a CRC-4 polynomial (multiplied by X4 then divided by X4 + X + 1), which generates a four bit remainder. This remainder is inserted in bit

position one of the four FASs of the following submultiframe before it is transmitted (see Table 12).

The submultiframe is then transmitted and, at the far end, the same process occurs. That is, a CRC-4 remainder is generated for each received submultiframe. These bits are compared with the bits received in position one of the four FASs of the next received submultiframe. This process takes place in both directions of transmission.

When more than 914 CRC-4 errors (out of a possible 1000) are counted in a one second interval, the framing algorithm will force a search for a new basic frame alignment. See Frame Algorithm section for more details.

The result of the comparison of the received CRC-4 remainder with the locally generated remainder will be transported to the far end by the E-bits. Therefore, if E1 = 0, a CRC-4 error was discovered in a submultiframe 1 received at the far end; and if E2 = 0, a CRC-4 error was discovered in a submultiframe 2 received at the far end. No submultiframe sequence numbers or re-transmission capabilities are supported with layer 1 PCM 30 protocol. See ITU-T G.704 and G.706 for more details on the operation of CRC-4 and E-bits.

There are two CRC multiframe alignment algorithm options selected by the  $\overline{AUTC}$  control bit (address 10H, page 01H). When  $\overline{AUTC}$  is zero, automatic CRC-to-non-CRC interworking is selected. When  $\overline{AUTC}$  is one and  $\overline{ARAI}$  is low, if CRC-4 multiframe alignment is not found in 400 msec, the transmit RAI will be continuously high until CRC-4 multiframe alignment is achieved.

The control bit for transmit E bits (TE, address 11H of page 01H) will have the same function in both states of  $\overline{AUTC}$ . That is, when CRC-4 synchronization is not achieved the state of the transmit E-bits will be the same as the state of the TE control bit. When CRC-4 synchronization is achieved the transmit E-bits will function as per ITU-T G.704. Table 12 outlines the operation of the  $\overline{AUTC}$ ,  $\overline{ARAI}$  and TALM control bits of the MT9074.

**CAS Signalling Multiframe in E1 mode**

The purpose of the signalling multiframe algorithm is to provide a scheme that will allow the association of a specific ABCD signalling nibble with the appropriate PCM 30 channel. Time slot 16 is reserved for the communication of Channel Associated Signalling (CAS) information (i.e., ABCD signalling bits for up to 30 channels). Refer to ITU-T

$\overline{AUTC}$	$\overline{ARAI}$	TALM	Description
0	0	X	Automatic CRC-interworking is activated. If no valid CRC MFAS is being received, transmit RAI will flicker high with every reframe (8msec.), this cycle will continue for 400 msec., then transmit RAI will be low continuously. The device will stop searching for CRC MFAS, continue to transmit CRC-4 remainders, stop CRC-4 processing, indicate CRC-to-non-CRC operation and transmit E-bits to be the same state as the TE control bit (page 01H, address 16H).
0	1	0	Automatic CRC-interworking is activated. Transmit RAI is low continuously.
0	1	1	Automatic CRC-interworking is activated. Transmit RAI is high continuously.
1	0	X	Automatic CRC-interworking is de-activated. If no valid CRC MFAS is being received, transmit RAI flickers high with every reframe (8 msec.), this cycle continues for 400 msec, then transmit RAI becomes high continuously. The device continues to search for CRC MFAS and transmit E-bits are the same state as the TE control bit. When $\overline{CRCSYN} = 0$ , the CRC MFAS search is terminated and the transmit RAI goes low.
1	1	0	Automatic CRC-interworking is de-activated. Transmit RAI is low continuously.
1	1	1	Automatic CRC-interworking is de-activated. Transmit RAI is high continuously.

**Table 12 - Operation of  $\overline{AUTC}$ ,  $\overline{ARAI}$  and TALM Control Bits (E1 Mode)**

G.704 and G.732 for more details on CAS multiframing requirements.

A CAS signalling multiframe consists of 16 basic frames (numbered 0 to 15), which results in a multiframe repetition rate of 2 msec. It should be noted that the boundaries of the signalling multiframe may be completely distinct from those of the CRC-4 multiframe. CAS multiframe alignment is based on a multiframe alignment signal (a 0000 bit sequence), which occurs in the most significant nibble of time slot 16 of basic frame 0 of the CAS multiframe. Bit 6 of this time slot is the multiframe alarm bit (usually designated Y). When CAS multiframing is acquired on the receive side, the transmit Y-bit is zero; when CAS multiframing is not acquired, the transmit Y-bit is one. Bits 5, 7 and 8 (usually designated X) are spare bits and are normally set to one if not used.

Time slot 16 of the remaining 15 basic frames of the CAS multiframe (i.e., basic frames 1 to 15) are reserved for the ABCD signalling bits for the 30 payload channels. The most significant nibbles are reserved for channels 1 to 15 and the least significant nibbles are reserved for channels 16 to 30. That is, time slot 16 of basic frame 1 has ABCD for channel 1 and 16, time slot 16 of basic frame 2 has ABCD for channel 2 and 17, through to time slot 16 of basic frame 15 has ABCD for channel 15 and 30.

## MT9074 Access and Control

### The Control Port Interface

The control and status of the MT9074 is achieved through a non-multiplexed parallel microprocessor port. The parallel port may be configured for Motorola style control signals (by setting pin INT/MOT low) or Intel style control signals (by setting pin INT/MOT high).

### Control and Status Register Access

The controlling microprocessor gains access to specific registers of the MT9074 through a two step process. First, writing to the Command/Address Register (CAR) selects one of the 15 pages of control and status registers (CAR address: AC4 = 0, AC3-AC0 = don't care, CAR data D7 - D0 = page number). Second, each page has a maximum of 16 registers that are addressed on a read or write to a non-CAR address (non-CAR: address AC4 = 1, AC3-AC0 = register address, D7-D0 = data). Once a page of memory is selected, it is only necessary to write to the CAR when a different page is to be accessed. See the AC Electrical Characteristics section.

Please note that for microprocessors with read/write cycles less than 200 ns, a wait state or a dummy operation (for C programming) between two

Page Address D <sub>7</sub> - D <sub>0</sub>	Register Description	Processor Access	ST-BUS Access
00000001 (01H)	Master Control	R/W	---
00000010 (02H)		R/W	
00000011 (03H)	Master Status	R	---
00000100 (04H)		R/W	
00000101 (05H)	Per Channel Transmit Signalling	R/W	CSTi
00000110 (06H)	Per Channel Transmit Signalling	R/W	CSTi
00000111 (07H)	Per Time Slot Control		---
00001000 (08H)	Per Time Slot Control	R/W	---
00001001 (09H)		R/W	
00001010 (0AH)	Per Channel Receive Signalling	R/W	CSTo
00001011 (0BH)	Per Channel Receive Signalling	R/W	CSTo
00001011 (0BH)	HDLC0 Control and Status	R/W	---
00001011 (0CH)	HDLC1 Control and Status	R/W	---

Table 13 - Page Summary

successive read/write operations to the HDLC FIFO is required.

Table 13 associates the MT9074 control and status pages with access and page descriptions.

**Identification Code**

The MT9074 shall be identified by the code 10101111, read from the identification code status register (page 03H, address 1FH).

**ST-BUS Streams**

In T1 mode, there is one control and one status ST-BUS stream that can be used to program / access channel associated signalling nibbles. CSTo contains the received channel associated signalling bits, and for those channels whose Per Time Slot Control word bit 1 "RPSIG" is set low, CSTi is used to control the transmit channel associated signalling. The DSTi and DSTo streams contain the transmit and receive voice and digital data. Only 24 of the 32 ST-BUS channels are used for each of DSTi, DSTo, CSTi and CSTo. In each case individual channel mapping is as illustrated in Table , "Table 6 - STBUS vs. DS1 to Channel Relationship(T1)," on page 14.

In E1 mode, the ST-BUS stream can also be used to access channel associated signalling nibbles. CSTo contains the received channel associated signalling bits (e.g., ITU-T R1 and R2 signalling),and for those channels whose Per Time Slot Control word bit 1 "RPSIG" is set low, CSTi is used to control the transmit channel associated signalling. The DSTi and DSTo streams contain the transmit and receive voice and digital data.

Only 30 of the 32 ST-BUS channels are used for each of DSTi, DSTo, CSTi and CSTo. In each case individual channel mapping is as illustrated in Table 10 Time slot to Channel Relationship.

**Reset Operation (Initialization)**

The MT9074 can be reset using the hardware  $\overline{\text{RESET}}$  pin (see pin description for external reset circuit requirements) for T1 and (pin 11 in PLCC, pin 84 in MQFP) or the software reset bit RST (page 1H, address 1AH) for E1/T1. When the device emerges from its reset state it will begin to function with the default settings described in Table 14 (T1) and Table 15 (E1), all control registers default to 00H. A reset operation takes 1 full frame (125 us) to complete.

Function	Status
Mode	D4
Loopbacks	Deactivated
SLC-96	Deactivated
Zero Coding	Deactivated
Line Codes	Deactivated
Data Link	Serial Mode
Signalling	CAS Registers
AB/ABCD Bit Debounce	Deactivated
Interrupts	masked
Error Insertion	Deactivated
HDLC0,1	Deactivated
Counters	Cleared
Transmit Data	All Ones

**Table 14 - Reset Status(T1)**

Function	Status
Mode	Termination
Loopbacks	Deactivated
Transmit FAS	C <sub>n</sub> 0011011
Transmit non-FAS	1/S <sub>n</sub> 1111111
Transmit MFAS (CAS)	00001111
Data Link	Deactivated
CRC Interworking	Activated
Signalling	CAS Registers
ABCD Bit Debounce	Deactivated
Interrupts	Masked
RxMF Output	Signalling Multiframe
Error Insertion	Deactivated
HDLCs	Deactivated
Counters	Cleared
Transmit Data	All Ones

**Table 15 - Reset Status(E1)**

**Transmit Data All Ones ( $\overline{\text{TxAO}}$ ) Operation**

The  $\overline{\text{TxAO}}$  (Transmit all ones) pin allows the PRI interface to transmit an all ones signal from the point of power-up without writing to any control registers. During this time the  $\overline{\text{IRQ}}$  pin is tristated. After the interface has been initialized normal operation can take place by making  $\overline{\text{TxAO}}$  high.



## Data Link Operation

### Data Link Operation in E1 mode

In E1 mode MT9074 has a user defined 4, 8, 12, 16 or 20 kbit/s data link for transport of maintenance and performance monitoring information across the PCM 30 link. This channel functions using the  $S_a$  bits ( $S_{a4} \sim S_{a8}$ ) of the PCM 30 timeslot zero non-frame alignment signal (NFAS). Since the NFAS is transmitted every other frame - a periodicity of 250 microseconds - the aggregate bit rate is a multiple of 4 kb/s. As there are five  $S_a$  bits independently available for this data link, the bit rate will be 4, 8, 12, 16 or 20 kb/s, depending on the bits selected for the Data Link (DL).

The  $S_a$  bits used for the DL are selected by setting the appropriate bits,  $S_{a4} \sim S_{a8}$ , to one in the Data Link Select Word (page 01H, address 17H, bits 4-0). Access to the DL is provided by pins TxDLCLK, TxDL, RxDLCLK and RxDL, which allow easy interfacing to an external controller.

Data to be transmit onto the line in the  $S_a$  bit position is clocked in from the TxDL pad (pin 65 in PLCC, pin 62 in MQFP) with the clock TxDLCLK (pin 64 in PLCC, pin 61 in MQFP). Although the aggregate clock rate equals the bit rate, it has a nominal pulse width of 244 ns, and it clocks in the TxDL as if it were a 2.048 Mb/s data stream. The clock can only be active during bit times 4 to 0 of the STBUS frame. The TxDL input signal is clocked into the MT9074 by the rising edge of TxDLCLK. If bits are selected to be a part of the DL, all other programmed functions for those  $S_a$  bit positions are overridden.

The RxDLCLK signal (pin 39 in PLCC, pin 20 in MQFP) is derived from the receive extracted clock and is aligned with the receive data link output RxDL. The HDB3 decoded receive data, at 2.048 Mbit/s, is clocked out of the device on pin RxDL (pin 40 in PLCC, pin 21 in MQFP). In order to facilitate the attachment of this data stream to a Data Link controller, the clock signal RxDLCLK consists of positive pulses, of nominal width of 244 ns, during the  $S_a$  bit cell times that are selected for the data link. Again, this selection is made by programming address 17H of master control page 01H. No DL data will be lost or repeated when a receive frame slip occurs. See the AC Electrical Characteristics for timing requirements.

### Data Link Operation in T1 mode

SLC-96 and ESF protocol allow for carrier messages to be embedded in the overhead bit position. The MT9074 provides 3 separate means of controlling these data links. See Data Link and Rx Equalization Control Word - address 12H, page 1H.

- The data links (transmit and receive) may be sourced (sunk) from an external controller using dedicated pins on the MT9074 in T1 mode (enabled by setting the bit 7 - EDL of the Data link Control Word).
- Bit - Oriented Messages may be transmit and received via a dedicated TxBOM register (page 1H, address 13H) and a RxBOM (page 3H, address 15H). Transmission is enabled by setting bit 6 - BIOMEn in the Data link Control Word. Bit - oriented messages may be periodically interrupted (up to once per second) for a duration of up to 100 milliseconds. This is to accommodate bursts of message - oriented protocols. See Table 16 for message structure.
- An internal HDLC controller may be attached to the data link.

### External Data Link

In T1 mode MT9074 has two pairs of pins (TxDL and TxDLCLK, RxDL and RxDLCLK) dedicated to transmitting and receiving bits in the selected overhead bit positions. Pins TxDLCLK and RxDLCLK are clock outputs available for clocking data into the MT9074 (for transmit) or external device (for receive information). Each clock operates at 4 Khz. In the SLC-96 mode the optional serial data link is multiplexed into the Fs bit position. In the ESF mode the serial data link is multiplexed into odd frames, i.e. the FDL bit positions.

### Bit - Oriented Messaging

In T1 mode MT9074 Bit oriented messaging may be selected by setting bit 6 (BIOMEn) in the Data Link Control Word (page 1H, address 12H). The transmit data link will contain the repeating serial data stream 11111110xxxxx0 where the byte 0xxxxx0 originates from the user programmed register "Transmit Bit Oriented Message" - page 1H address 13H. The receive BIOM register "Receive Bit Oriented Message" - page 3H, address 15H, will contain the last received valid message (the 0xxxxx0 portion of the incoming serial bit stream). To prevent spurious inputs from creating false

Octet #	8	7	6	5	4	3	2	1	Content
1	F	L	A	G					01111110
2	S	A	P	I		C / R		EA	00111000 or 00111010
3	T	E	I					EA	00000001
4	C	O	N	T	R	O	L		00000011
5	G3	LV	G4	U1	U2	G5	SL	G6	to
6	FE	SE	LB	G1	R	G2	Nm	NI	to
7	G3	LV	G4	U1	U2	G5	SL	G6	to-1
8	FE	SE	LB	G1	R	G2	Nm	NI	to-1
9	G3	LV	G4	U1	U2	G5	SL	G6	to-2
10	FE	SE	LB	G1	R	G2	Nm	NI	to-2
11	G3	LV	G4	U1	U2	G5	SL	G6	to-3
12	FE	SE	LB	G1	R	G2	Nm	NI	to-3
13	F C S								VARIABLE
14									

Table 16 - Message Oriented Performance Report Structure (T1.403 and T1.408)

<b>Note:</b>	<u>ADDRESS</u>	<u>INTERPRETATION</u>
	00111000	SAPI = 14, C/R = 0 (CI) EA = 0
	00111010	SAPI = 14, C/R = 1(Carrier) EA = 0
	00000001	TEI = 0, EA =1
	<u>CONTROL</u>	<u>INTERPRETATION</u>
	00000011	Unacknowledged Information Transfer
	<u>ONE SECOND REPORT</u>	<u>INTERPRETATION</u>
	G1 = 1	CRC Error Event =1
	G2 =1	1 < CRC Error Event < 5
	G3 =1	5 < CRC Error Event < 10
	G4 =1	10 < CRC Error Event < 100
	G5 =1	100 < CRC Error Event < 319
	G6 =1	CRC Error Event > 320
	SE = 1	Severely - Errored Framing Event >=1
	FE = 1	Frame Synchronization Bit Error Event >=1
	LV = 1	Line code Violation Event >=1
	SL = 1	Slip Event >=1
	LB = 1	Payload Loopback Activated
	U1,U2 = 0	Under Study for sync.
	R = 0	Reserved - set to 0
	NmNI = 00, 01, 10, 11	One Second Module 4 counter
	<u>FCS</u>	<u>INTERPRETATION</u>
	VARIABLE	CRC16 Frame Check Sequence

messages, a new message must be present in 7 of the last 10 appropriate byte positions before being loaded into the receive BIOM register. When a new message has been received, a maskable interrupt (maskable by setting bit 1 low in Interrupt Mask Word Three - page 1H, address 1EH) may occur.

**Dual HDLC**

MT9074 has two embedded HDLC controllers (HDLC0, HDLC1) each of which includes the following features:

- Independent transmit and receive FIFO's;
- Receive FIFO maskable interrupts for nearly full (programmable interrupt levels) and overflow conditions;
- Transmit FIFO maskable interrupts for nearly empty (programmable interrupt levels) and underflow conditions;
- Maskable interrupts for transmit end-of-packet and receive end-of-packet;
- Maskable interrupts for receive bad-frame (includes frame abort);
- Transmit end-of-packet and frame-abort functions.

**HDLC0 Functions**

In T1 mode ESF Data Link (DL) can be connected to internal HDLC0, operating at a bit rate of 4 kbits/sec. HDLC0 can be activated by setting the control bit 5, address 12H in Master Control Page 0. Interrupts from HDLC0 are masked when it is disconnected.

In E1 mode when connected to the Data Link (DL) HDLC0 will operate at a selected bit rate of 4, 8, 12, 16 or 20 kbits/sec. HDLC0 can be selected by setting the control bit HDLC0 (page 01H, address 12H). When this bit is zero all interrupts from HDLC0 are masked. For more information refer to following sections.

**HDLC1 Functions**

In T1 mode DS1 channel 24 can be connected to HDLC1, operating at 56 or 64 Kb/s. HDLC1 can be activated by setting the control bit HDLC1 (page 01H, address 12H). Setting control bit H1R64 (address 12 H on page 01H) high selects 64 Kb/s operation for HDLC1. Setting this bit low selects 56 Kb/s for HDLC1. Interrupts from HDLC1 are masked when it is disconnected.

In E1 mode this controller may be connected to time slot 16 under Common Channel Signalling (CCS)

mode. It should be noted that the AIS16S function will always be active and the TAIS16 (page 01H, address 11h) function will override all other transmit signalling.

HDLC1 can be selected by setting the control bit HDLC1. When this bit is zero all interrupts from HDLC1 are masked.

**HDLC Description**

The HDLC handles the bit oriented packetized data transmission as per X.25 level two protocol defined by ITU-T. It provides flag and abort sequence generation and detection, zero insertion and deletion, and Frame Check Sequence (FCS) generation and detection. A single byte, dual byte and all call address in the received frame can be recognized. Access to the receive FCS and inhibiting of transmit FCS for terminal adaptation are also provided. Each HDLC controller has a 128 byte deep FIFO associated with it. The status and interrupt flags are programmable for FIFO depths that can vary from 16 to 128 bytes in steps of 16 bytes. These and other features are enabled through the HDLC control registers on page 0BH and 0CH.

**HDLC Frame structure**

In T1 mode or E1 mode a valid HDLC frame begins with an opening flag, contains at least 16 bits of address and control or information, and ends with a 16 bit FCS followed by a closing flag. Data formatted in this manner is also referred to as a "packet". Refer to Table 17: HDLC Frame Format

Flag (7E)	Data Field	FCS	Flag (7E)
One Byte 01111110	n Bytes $n \geq 2$	Two Bytes	One Byte 01111110

**Table 17 - HDLC Frame Format**

All HDLC frames start and end with a unique flag sequence "01111110". The transmitter generates these flags and appends them to the packet to be transmitted. The receiver searches the incoming data stream for the flags on a bit- by-bit basis to establish frame synchronization.

The data field consists of an address field, control field and information field. The address field consists of one or two bytes directly following the opening flag. The control field consists of one byte directly following the address field. The information field immediately follows the control field and consists of

N bytes of data. The HDLC does not distinguish between the control and information fields and a packet does not need to contain an information field to be valid.

The FCS field, which precedes the closing flag, consists of two bytes. A cyclic redundancy check utilizing the CRC-CCITT standard generator polynomial " $X^{16}+X^{12}+X^5+1$ " produces the 16-bit FCS. In the transmitter the FCS is calculated on all bits of the address and data field. The complement of the FCS is transmitted, most significant bit first, in the FCS field. The receiver calculates the FCS on the incoming packet address, data and FCS field and compares the result to "F0B8". If no transmission errors are detected and the packet between the flags is at least 32 bits in length then the address and data are entered into the receive FIFO minus the FCS which is discarded.

### Data Transparency (Zero Insertion/Deletion)

Transparency ensures that the contents of a data packet do not imitate a flag, go-ahead, frame abort or idle channel. The contents of a transmitted frame, between the flags, is examined on a bit-by-bit basis and a 0 bit is inserted after all sequences of 5 contiguous 1 bits (including the last five bits of the FCS). Upon receiving five contiguous 1s within a frame the receiver deletes the following 0 bit.

### Invalid Frames

A frame is invalid if one of the following four conditions exists (Inserted zeros are not part of a valid count):

- If the FCS pattern generated from the received data does not match the "F0B8" pattern then the last data byte of the packet is written to the received FIFO with a 'bad packet' indication.
- A short frame exists if there are less than 25 bits between the flags. Short frames are ignored by the receiver and nothing is written to the receive FIFO.
- Packets which are at least 25 bits in length but less than 32 bits between the flags are also invalid. In this case the data is written to the FIFO but the last byte is tagged with a "bad packet" indication.
- If a frame abort sequence is detected the packet is invalid. Some or all of the current packet will reside in the receive FIFO, assuming the packet length before the abort sequence was at least 26 bits long.

### Frame Abort

The transmitter will abort a current packet by substituting a zero followed by seven contiguous 1s in place of the normal packet. The receiver will abort upon reception of seven contiguous 1s occurring between the flags of a packet which contains at least 26 bits.

Note that should the last received byte before the frame abort end with contiguous 1s, these are included in the seven 1s required for a receiver abort. This means that the location of the abort sequence in the receiver may occur before the location of the abort sequence in the originally transmitted packet. If this happens then the last data written to the receive FIFO will not correspond exactly with the last byte sent before the frame abort.

### Interframe Time Fill and Link Channel States

When the HDLC transmitter is not sending packets it will wait in one of two states

- Interframe Time Fill state: This is a continuous series of flags occurring between frames indicating that the channel is active but that no data is being sent.
- Idle state: An idle Channel occurs when at least 15 contiguous 1s are transmitted or received.

In both states the transmitter will exit the wait state when data is loaded into the transmitter FIFO.

### Go-Ahead

A go ahead is defined as the pattern "011111110" (contiguous 7Fs) and is the occurrence of a frame abort sequence followed by a zero, outside of the boundaries of a normal packet. Being able to distinguish a proper (in packet) frame abort sequence from one occurring outside of a packet allows a higher level of signalling protocol which is not part of the HDLC specifications.

### HDLC Functional Description

The HDLC transceiver can be reset by either the power reset input signal or by the HRST Control bit in the test control register (software reset). When reset, the HDLC Control Registers are cleared, resulting in the transmitter and receiver being disabled. The Receiver and Transmitter can be enabled independent of one another through Control Register 1. The transceiver input and output are enabled when the enable control bits in Control Register 1 are set. Transmit to receive loopback as

well as a receive to transmit loopback are also supported. Transmit and receive bit rates and enables can operate independently. In MT9074 the transceiver can operate at a continuous rate independent of RXcen and TXcen (free run mode) by setting the Frun bit of Control Register 1.

Received packets from the serial interface are sectioned into bytes by an HDLC receiver that detects flags, checks for go-ahead signals, removes inserted zeros, performs a cyclical redundancy check (CRC) on incoming data, and monitors the address if required. Packet reception begins upon detection of an opening flag. The resulting bytes are concatenated with two status bits (RQ9, RQ8) and placed in a receiver first-in-first-out (Rx FIFO); a buffer register that generates status and interrupts for microprocessor read control.

In conjunction with the control circuitry, the microprocessor writes data bytes into a Tx buffer register (Tx FIFO) that generates status and interrupts. Packet transmission begins when the microprocessor writes a byte to the Tx FIFO. Two status bits are added to the Tx FIFO for transmitter control of frame aborts (FA) and end of packet (EOP) flags. Packets have flags appended, zeros inserted, and a CRC, also referred to as frame checking sequence (FCS), added automatically during serial transmission. When the Tx FIFO is empty and finished sending a packet, Interframe Time Fill bytes (continuous flags (7E hex)), or Mark Idle (continuous ones) are transmitted to indicate that the channel is idle.

### HDLC Transmitter

Following initialization and enabling, the transmitter is in the Idle Channel state (Mark Idle), continuously sending ones. Interframe Time Fill state (Flag Idle) is selected by setting the Mark idle bit in Control Register 1 high. The Transmitter remains in either of these two states until data is written to the Tx FIFO. Control Register 1 bits EOP (end of packet) and FA (Frame Abort) are set as status bits before the microprocessor loads 8 bits of data into the 10 bit wide FIFO (8 bits data and 2 bits status). To change the tag bits being loaded in the FIFO, Control Register 1 must be written to before writing to the FIFO. However, EOP and FA are reset after writing to the TX FIFO. The Transmit Byte Count Register may also be used to tag an end of packet. The register is loaded with the number of bytes in the packet and decrements after every write to the Tx FIFO. When a count of one is reached, the next byte written to the FIFO is tagged as an end of packet. The register may be made to cycle through the same count if the

packets are of the same length by setting Control Register 2 bit Cycle.

If the transmitter is in the Idle Channel state when data is written to the Tx FIFO, then an opening flag is sent and data from Tx FIFO follows. Otherwise, data bytes are transmitted as soon as the current flag byte has been sent. Tx FIFO data bytes are continuously transmitted until either the FIFO is empty or an EOP or FA status bit is read by the transmitter. After the last bit of the EOP byte has been transmitted, a 16-bit FCS is sent followed by a closing flag. When multiple packets of data are loaded into Tx FIFO, only one flag is sent between packets.

Frame aborts (the transmission of 7F hex), are transmitted by tagging a byte previously written to the Tx FIFO. When a byte has an FA tag, then an FA is sent instead of that tagged byte. That is, all bytes previous to but not including that byte are sent. After a Frame Abort, the transmitter returns to the Mark Idle or Interframe Time Fill state, depending on the state of the Mark idle control bit.

Tx FIFO underrun will occur if the FIFO empties and the last byte did not have either an EOP or FA tag. A frame abort sequence will be sent when an underrun occurs.

Below is an example of the transmission of a three byte packet ('AA' '03' '77' hex) (Interframe time fill). TXcen can be enabled before or after this sequence.

- (a) Write '04'hex to Control Register 1  
-Mark idle bit set
- (b) Write 'AA' hex to TX FIFO  
-Data byte
- (c) Write '03'hex to TX FIFO  
-Data byte
- (d) Write '34'hex to Control Register 1  
-TXEN; EOP; Mark idle bits set
- (e) Write '77'hex to TX FIFO  
-Final data byte

The transmitter may be enabled independently of the receiver. This is done by setting the TXEN bit of the Control Register. Enabling happens immediately upon writing to the register. Disabling using TXen will occur after the completion of the transmission of the present packet; the contents of the FIFO are not cleared. Disabling will consist of stopping the transmitter clock. The Status and Interrupt Registers may still be read and the FIFO and Control Registers may be written to while the transmitter is disabled. The transmitted FCS may be inhibited using the TcrCi bit of Control Register 2. In this mode the opening



flag followed by the data and closing flag is sent and zero insertion still included, but no CRC. That is, the FCS is injected by the microprocessor as part of the data field. This is used in V.120 terminal adaptation for synchronous protocol sensitive UI frames.

**HDLC Receiver**

After initialization and enabling, the receiver clocks in serial data, continuously checking for Go-aheads (0 1111 1110), flags (0111 1110), and Idle Channel states (at least fifteen ones). When a flag is detected, the receiver synchronizes itself to the serial stream of data bits, automatically calculating the FCS. If the data length between flags after zero removal is less than 25 bits, then the packet is ignored so no bytes are loaded into Rx FIFO. When the data length after zero removal is between 25 and 31 bits, a first byte and bad FCS code are loaded into the Rx FIFO (see definition of RQ8 and RQ9 below). For an error-free packet, the result in the CRC register should match the HEX pattern of 'F0B8' when a closing flag is detected.

If address recognition is required, the Receiver Address Recognition Registers are loaded with the desired address and the Adrec bit in the Control Register 1 is set high. Bit 0 of the Address Registers is used as an enable bit for that byte, thus allowing either or both of the first two bytes to be compared to the expected values. Bit 0 of the first byte of the address received (address extension bit) will be monitored to determine if a single or dual byte address is being received. If this bit is 0 then a two byte address is being received and then only the first six bits of the first address byte are compared. An all call condition is also monitored for the second address byte; and if received the first address byte is ignored (not compared with mask byte). If the address extension bit is a 1 then a single byte address is being received. In this case, an all call condition is monitored for in the first byte as well as the mask byte written to the comparison register and the second byte is ignored. Seven bits of address comparison can be realized on the first byte if this is a single byte address by setting the Seven bit of Control Register 2.

The following two Status Register bits (RQ8 and RQ9) are appended to each data byte as it is written to the Rx FIFO. They indicate that a good packet has been received (good FCS and no frame abort), or a bad packet with either incorrect FCS or frame abort. The Status and Interrupt Registers should be read before reading the Rx FIFO since status and interrupt information correspond to the byte at the output of the FIFO (i.e. the byte about to be read). The Status Register bits are encoded as follows:

RQ9	RQ8	Byte status
1	1	last byte (bad packet)
0	1	first byte
1	0	last byte (good packet)
0	0	packet byte

The end-of-packet-detect (EOPD) interrupt indicates that the last byte written to the Rx FIFO was an EOP byte (last byte in a packet). The end-of-packet-read (EopR) interrupt indicates that the byte about to be read from the Rx FIFO is an EOP byte (last byte in a packet). The Status Register should be read to see if the packet is good or bad before the byte is read.

A minimum size packet has an 8-bit address, an 8-bit control byte, and a 16-bit FCS pattern between the opening and closing flags (see Section 9.3.2). Thus, the absence of a data transmission error and a frame length of at least 32 bits results in the receiver writing a valid packet code with the EOP byte into Rx FIFO. The last 16 bits before the closing flag are regarded as the FCS pattern and will not be transferred to the receiver FIFO. Only data bytes (Address, Control, Information) are loaded into the Rx FIFO.

In the case of an Rx FIFO overflow, no clocking occurs until a new opening flag is received. In other words, the remainder of the packet is not clocked into the FIFO. Also, the top byte of the FIFO will not be written over. If the FIFO is read before the reception of the next packet then reception of that packet will occur. If two beginning of packet conditions (RQ9=0;RQ8=1) are seen in the FIFO, without an intermediate EOP status, then overflow occurred for the first packet.

The receiver may be enabled independently of the transmitter. This is done by setting the RXEN bit of Control Register 1. Enabling happens immediately upon writing to the register. Disabling using RXEN will occur after the present packet has been completely loaded into the FIFO. Disabling can occur during a packet if no bytes have been written to the FIFO yet. Disabling will consist of disabling the internal receive clock. The FIFO, Status, and Interrupt Registers may still be read while the receiver is disabled. Note that the receiver requires a flag before processing a frame, thus if the receiver is enabled in the middle of an incoming packet it will ignore that packet and wait for the next complete one.

The receive CRC can be monitored in the Rx CRC Registers. These registers contain the actual CRC sent by the other transmitter in its original form; that is, MSB first and bits inverted. These registers are



updated by each end of packet (closing flag) received and therefore should be read when an end of packet is received so that the next packet does not overwrite the registers.

**Slip Buffers**

**Slip Buffer in T1 mode**

In T1 mode MT9074 contains two sets of slip buffers, one on the transmit side, and one on the receive side. Both sides may perform a controlled slip. The mechanisms that govern the slip function are a function of backplane timing and the mapping between the ST-BUS channels and the DS1 channels. The slip mechanisms are different for the transmit and receive slip buffers. The extracted 1.544 Mhz clock (E1.5o) and the internally generated transmit 1.544 Mhz clock are distinct. Slips on the transmit side are independent from slips on the receive side.

The transmit slip buffer has data written to it from the near end 2.048 Mb/s stream. The data is clocked out of the buffer using signals derived from the transmit 1.544 Mhz clock. The transmit 1.544 Mhz clock is always phase locked to the DSTi 2.048 Mb/s stream. If the system 4.096 Mhz clock ( $\overline{C4b}$ ) is internally generated (pin BS/LS low), then it is hard locked to

the 1.544 Mhz clock. No phase drift or wander can exist between the two signals - therefore no slips will occur. The delay through the transmit elastic buffer is then fixed, and is a functions of the relative mapping between the DSTi channels and the DS1 timeslots. These delays vary with the position of the channel in the frame. For example, DS1 timeslot 1 sits in the elastic buffer for approximately 1 usec and DS1 timeslot 24 sits in the elastic buffer for approximately 32 usec.

If the system 4.096 Mhz clock ( $\overline{C4b}$ ) is externally generated (pin BS/LS high), the transmit 1.544 Mhz clock is phase locked to it, but the PLL is designed to filter jitter present in the  $\overline{C4b}$  clock. As a result phase drift will result between the two signals. The delay through the transmit elastic buffer will vary in accordance with the input clock drift, as well as being a function of the relative mapping between the DSTi channels and the DS1 timeslots. If the read pointers approach the write pointers (to within approximately 1 usec) or the delay through the transmit buffer exceeds 218 usecs a controlled slip will occur. The contents of a single frame of DS1 data will be skipped or repeated; a maskable interrupt (masked by setting bit 1 - TxSLPI high in Interrupt Mask Word Zero - page 1H, address 1bH) will be generated, and the status bit TSLIP (page 3H, address 17H) of MSB Transmit Slip Buffer register will toggle. The direction of the slip is indicated by bit 6 of the same register

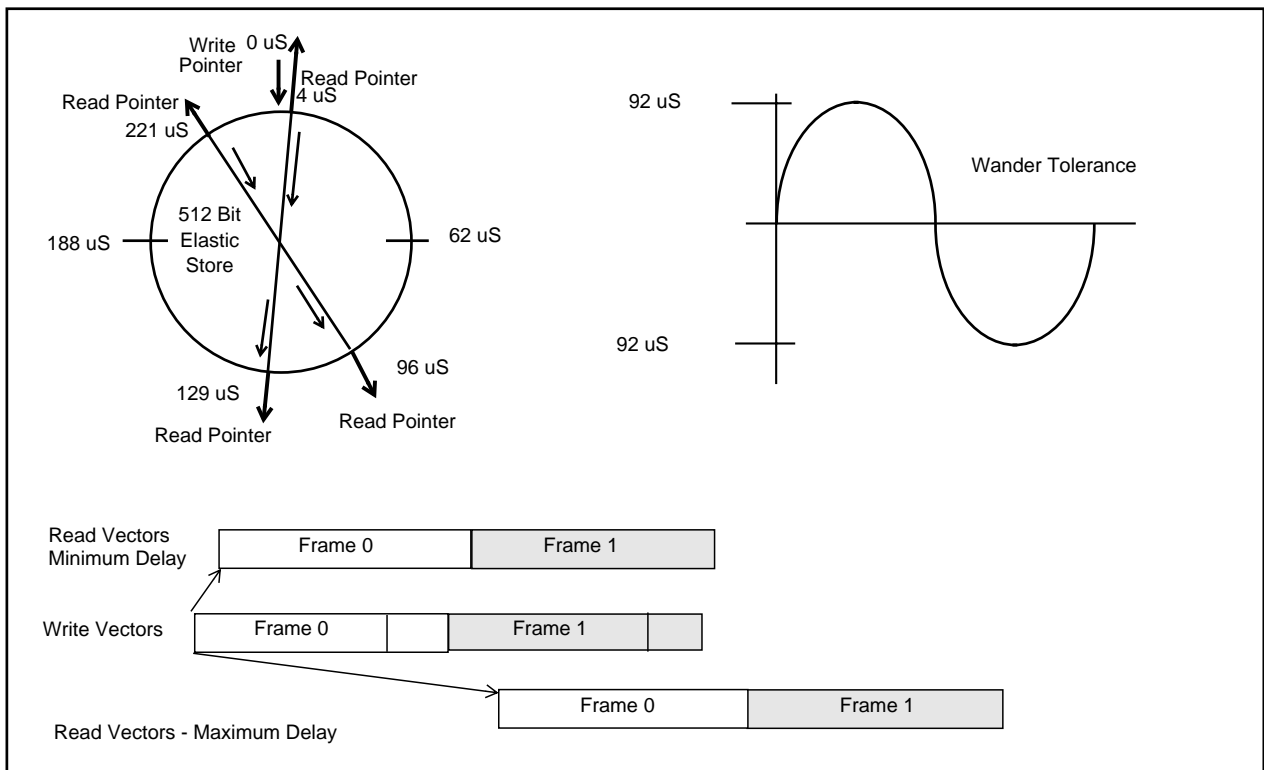

**Figure 12 - Read and write pointers in the transmit slip buffers**

(TSLPD). The relative phase delay between the system frame boundary and the transmit elastic frame read boundary is measured every frame and reported in the Transmit Slip Buffer Delay register (page 3H, address 17H). In addition the relative offset between these frame boundaries may be programmed by writing to this register. Every write to Transmit Elastic Buffer Set Delay Word resets the transmit elastic frame count bit TxSBMSB (address 17H, page 3H). After a write the delay through the slip buffer is less than 1 frame in duration. Each write operation will result in a disturbance of the transmit DS1 frame boundary, causing the far end to go out of sync. Writing BC (hex) into the TxSBDLY register maximizes the wander tolerance before a controlled slip occurs. Under normal operation no slips should occur in the transmit path. Slips will only occur if the input  $\overline{C4b}$  clock has excess wander, or the Transmit Elastic Buffer Set Delay Word register is initialized too close to the slip pointers after system initialization.

The two frame receive elastic buffer is attached between the 1.544 Mbit/s DS1 receive side and the 2.048 Mbit/s ST-BUS side of the MT9074. Besides performing rate conversion, this elastic buffer is configured as a slip buffer which absorbs wander and low frequency jitter in multi-trunk applications. The received DS1 data is clocked into the slip buffer with the E1.5o clock and is clocked out of the slip buffer with the system  $\overline{C4b}$  clock. The E1.5o extracted clock is generated from, and is therefore phase-locked with, the receive DS1 data. In the case of Internal mode (pin BS/ $\overline{LS}$  set low) operation, the E1.5o clock may be phase-locked to the  $\overline{C4b}$  clock by an internal phase locked loop (PLL). Therefore, in a single trunk system the receive data is in phase with the E1.5o clock, the  $\overline{C4b}$  clock is phase locked to the E1.5o clock, and the read and write positions of the slip buffer track each other.

In a multi-trunk slave or loop-timed system (i.e., PABX application) a single trunk will be chosen as a network synchronizer, which will function as described in the previous paragraph. The remaining trunks will use the system timing derived from the synchronizer to clock data out of their slip buffers. Even though the DS1 signals from the network are synchronous to each other, due to multiplexing, transmission impairments and route diversity, these signals may jitter or wander with respect to the synchronizing trunk signal. Therefore, the C1.50 clocks of non-synchronized trunks may wander with respect to the C1.50 clock of the synchronizer and the system bus. Network standards state that, within limits, trunk interfaces must be able to receive error-free data in the presence of jitter and wander (refer to network requirements for jitter and wander

tolerance). The MT9074 will allow 92 usec (140 UI, DS1 unit intervals) of wander and low frequency jitter before a frame slip will occur.

When the  $\overline{C4b}$  and the E1.5o clocks are not phase-locked, the rate at which data is being written into the slip buffer from the DS1 side may differ from the rate at which it is being read out onto the ST-BUS. If this situation persists, the delay limits stated in the previous paragraph will be violated and the slip buffer will perform a controlled frame slip. That is, the buffer pointers will be automatically adjusted so that a full DS1 frame is either repeated or lost. All frame slips occur on frame boundaries.

The minimum delay through the receive slip buffer is approximately 1 usec and the maximum delay is approximately 249 uS. Figure 13 illustrates the relationship between the read and write pointers of the receive slip buffer (contiguous time slot mapping). Measuring clockwise from the write pointer, if the read page pointer comes within 8 usec of the write page pointer a frame slip will occur, which will put the read page pointer 157 usec from the write page pointer. Conversely, if the read page pointer moves more than 249 usec from the write page pointer, a slip will occur, which will put the read page pointer 124 usec from the write page pointer. This provides a worst case hysteresis of 92 usec peak = 142 U.I.

The RSLIP and RSLPD status bits (page 3H, address 13H, bits 7 and 6 respectively) give indication of a receive slip occurrence and direction. A maskable interrupt RxSLPI (page 1H, address 1BH, bit 0 - set high to mask) is also provided. RSLIP changes state in the event of a slip. If RSLPD=0, the slip buffer has overflowed and a frame was lost; if RSLPD=1, an underflow condition occurred and a frame was repeated

### Slip Buffer in E1 mode

In E1 mode in addition to the elastic buffer in the jitter attenuator(JA), another elastic buffer (two frames deep) is present, attached between the receive side and the ST-BUS (or GCI Bus) side of the MT9074 in E1 mode. This elastic buffer is configured as a slip buffer which absorbs wander and low frequency jitter in multi-trunk applications. The received PCM 30 data is clocked into the slip buffer with the E1.5o clock and is clocked out of the slip buffer with the  $\overline{C4b}$  clock. The E1.5o extracted clock is generated from, and is therefore phase-locked with, the receive PCM 30 data. In normal operation, the  $\overline{C4b}$  clock will be phase-locked to the E1.5o clock by a phase locked loop (PLL). Therefore, in a single trunk

system the receive data is in phase with the E1.5o clock, the C4b clock is phase-locked to the E1.5o clock, and the read and write positions of the slip buffer will remain fixed with respect to each other.

In a multi-trunk slave or loop-timed system (i.e., PABX application) a single trunk will be chosen as a network synchronizer, which will function as described in the previous paragraph. The remaining trunks will use the system timing derived from the synchronizer to clock data out of their slip buffers. Even though the PCM 30 signals from the network are synchronous to each other, due to multiplexing, transmission impairments and route diversity, these signals may jitter or wander with respect to the synchronizing trunk signal. Therefore, the E1.5o clocks of non-synchronizer trunks may wander with respect to the C1.50 clock of the synchronizer and the system bus.

Network standards state that, within limits, trunk interfaces must be able to receive error-free data in the presence of jitter and wander (refer to network requirements for jitter and wander tolerance). The MT9074 will allow a maximum of 26 channels (208 UI, unit intervals) of wander and low frequency jitter before a frame slip will occur.

The minimum delay through the receive slip buffer is approximately two channels and the maximum delay is approximately 60 channels (see Figure 14).

When the C4b and the E1.5o clocks are not phase-locked, the rate at which data is being written into the slip buffer from the PCM 30 side may differ from the rate at which it is being read out onto the ST-BUS. If this situation persists, the delay limits stated in the previous paragraph will be violated and the slip buffer will perform a controlled frame slip. That is, the buffer pointers will be automatically adjusted so that a full PCM 30 frame is either repeated or lost. All frame slips occur on PCM 30 frame boundaries.

Two status bits, RSLIP and RSLPD (page03H, address13H) give indication of a slip occurrence and direction. RSLIP changes state in the event of a slip. If RSLPD=0, the slip buffer has overflowed and a frame was lost; if RSLPD=1, an underflow condition occurred and a frame was repeated. A maskable interrupt SLPI (page 01H, address 1BH) is also provided.

Figure 14 illustrates the relationship between the read and write pointers of the receive slip buffer. Measuring clockwise from the write pointer, if the read pointer comes within two channels of the write pointer a frame slip will occur, which will put the read pointer 34 channels from the write pointer. Conversely, if the read pointer moves more than 60

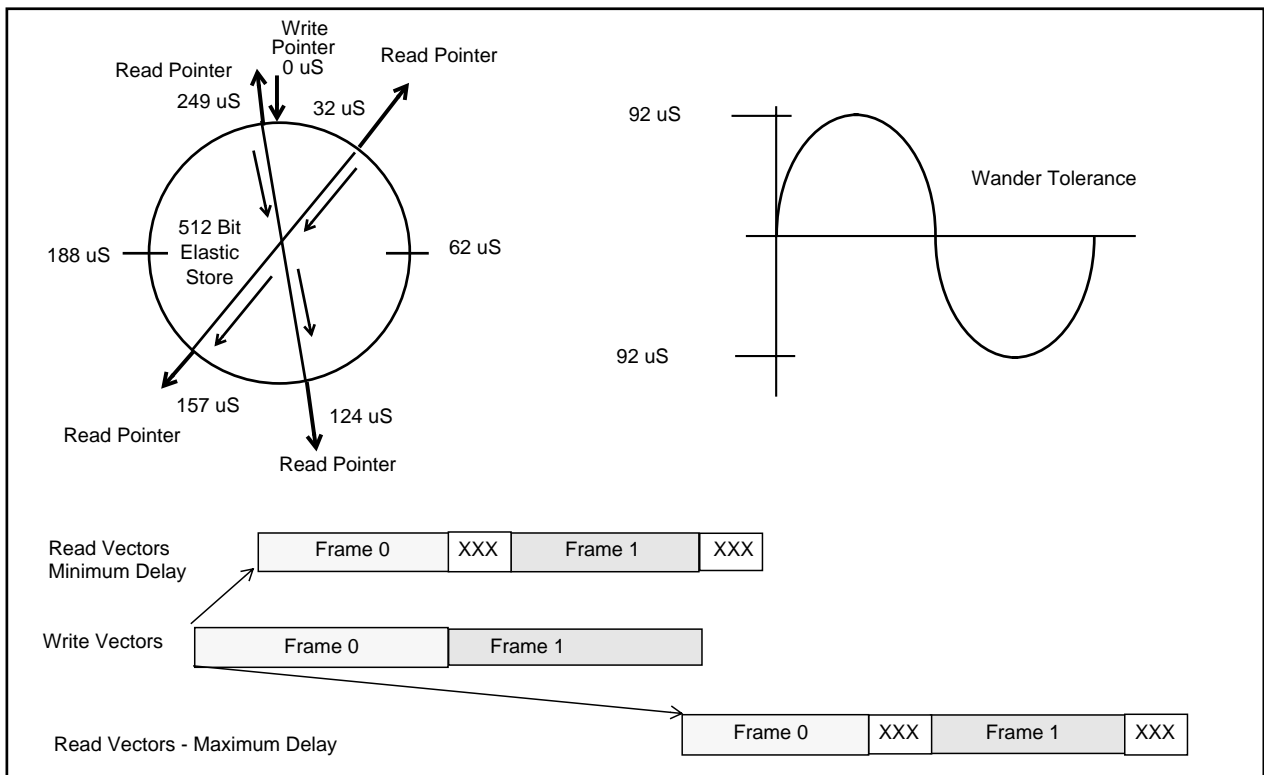

Figure 13 - Read and write pointers in the receive slip buffers

channels from the write pointer, a slip will occur, which will put the read pointer 28 channels from the write pointer. This provides a worst case hysteresis of 13 channels peak (26 channels peak-to-peak) or a wander tolerance of 208 UI.

**Framing Algorithm**

**Frame Alignment in T1 Mode**

In T1 mode MT9074 will synchronize to DS1 lines formatted with either the D4 or ESF protocol. In either mode the framer maintains a running 3 bit history of received data for each of the candidate bit positions. Candidate bit positions whose incoming patterns fail to match the predicted pattern (based on the 3 bit history) are winnowed out. If, after a 10 bit history has been examined, only one candidate bit position remains within the framing bit period, the receive side timebase is forced to align to that bit position. If no candidates remain after a 10 bit history, the process is re-initiated. If multiple candidates exist after a 24 bit history timeout period, the framer forces the receive side timebase to synchronize to the next incoming valid candidate bit position. In the event of a reframe, the framer starts searching at the next bit position over. This prevents persistent locking to a mimic as the controller may initiate a software controlled reframe in the event of locking to a mimic.

Under software control the framing criteria may be tuned (see Framing Mode Select Register, page 1H, address 10H). Selecting D4 framing invites a further decision whether or not to include a cross check of Fs bits along with the Ft bits. If Fs bits are checked (by setting control bit CXC high - bit 5 of the Framing Mode Select Word, page 1H, address 10H),

multiframe alignment is forced at the same time as terminal frame alignment. If only Ft bits are checked, multiframe alignment is forced separately, upon detection of the Fs bit history of 00111 (for normal D4 trunks) or 000111000111 (for SLC-96 trunks). For D4 trunks, a reframe on the multiframe alignment may be forced at any time without affecting terminal frame alignment.

In ESF mode the circuit will optionally confirm the CRC-6 bits before forcing a new frame alignment. This is programmed by setting control bit CXC high (bit 5 of the Framing Mode Select Word, page 1H, address 10H). A CRC-6 confirmation adds a minimum of 6 milliseconds to the reframe time. If no CRC-6 match is found after 16 attempts, the framer moves to the next valid candidate bit position (assuming other bit positions contain a match to the framing pattern) or re-initiates the whole framing procedure (assuming no bit positions have been found to match the framing pattern).

The framing circuit is off - line. During a reframe, the rest of the circuit operates synchronous with the last frame alignment. Until such time as a new frame alignment is achieved, the signalling bits are frozen in their states at the time that frame alignment was lost, and error counting for Ft, Fs, ESF framing pattern or CRC-6 bits is suspended.

**Frame Alignment in E1 mode**

In E1 mode MT9074 contains three distinct framing algorithms: basic frame alignment, signalling multiframe alignment and CRC-4 multiframe alignment. Figure 17 is a state diagram that illustrates these algorithms and how they interact.

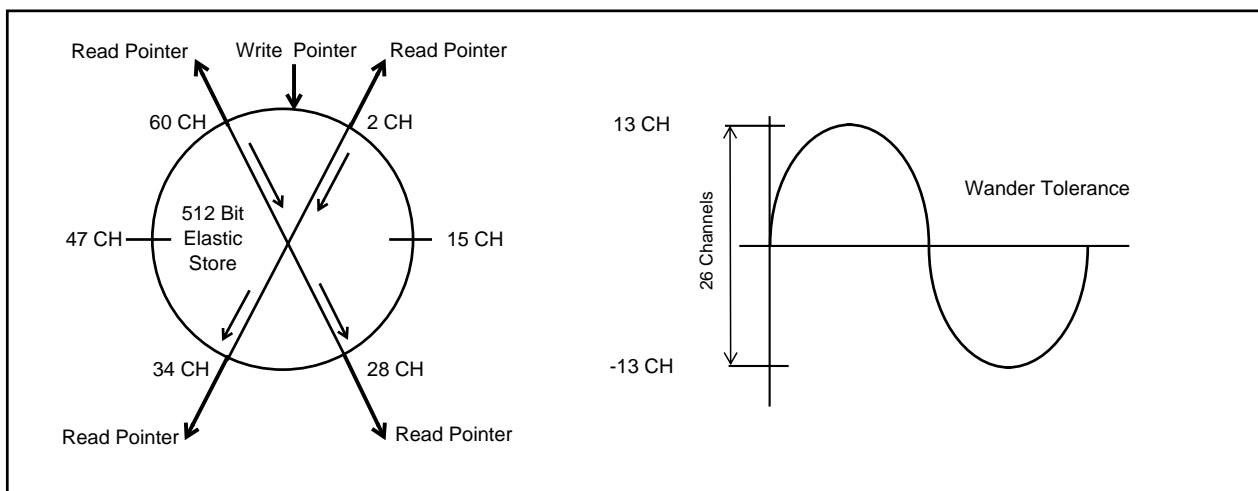

**Figure 14 - Read and Write Pointers in the Slip Buffers**

After power-up, the basic frame alignment framer will search for a frame alignment signal (FAS) in the PCM 30 receive bit stream. Once the FAS is detected, the corresponding bit 2 of the non-frame alignment signal (NFAS) is checked. If bit 2 of the NFAS is zero a new search for basic frame alignment is initiated. If bit 2 of the NFAS is one and the next FAS is correct, the algorithm declares that basic frame synchronization has been found (i.e., page 03H, address 10H, bit 7,  $\overline{\text{SYNC}}$  is zero).

Once basic frame alignment is acquired the signalling and CRC-4 multiframe searches will be initiated. The signalling multiframe algorithm will align to the first multiframe alignment signal pattern (MFAS = 0000) it receives in the most significant nibble of channel 16 (page 3, address 10H, bit 6,  $\overline{\text{MFSYNC}} = 0$ ). Signalling multiframing will be lost when two consecutive multiframes are received in error.

The CRC-4 multiframe alignment signal is a 001011 bit sequence that appears in PCM 30 bit position one of the NFAS in frames 1, 3, 5, 7, 9 and 11 (see Table 9). In order to achieved CRC-4 synchronization two consecutive CRC-4 multiframe alignment signals must be received without error (page 03H, address 10H  $\overline{\text{CRCSYN}} = 0$ ).

The E1 framing algorithm supports automatic interworking of interfaces with and without CRC-4 processing capabilities. That is, if an interface with CRC-4 capability, achieves valid basic frame alignment, but does not achieve CRC-4 multiframe alignment by the end of a predefined period, the distant end is considered to be a non-CRC-4 interface. When the distant end is a non-CRC-4 interface, the near end automatically suspends receive CRC-4 functions, continues to transmit CRC-4 data to the distant end with its E-bits set to zero, and provides a status indication. Naturally, if the distant end initially achieves CRC-4 synchronization, CRC-4 processing will be carried out by both ends. This feature is selected when control bit  $\overline{\text{AUTC}}$  (page 01H, address 10H) is set to zero.

#### Notes for Synchronization State Diagram (Figure 15)

- 1) The basic frame alignment, signalling multiframe alignment, and CRC-4 multiframe alignment functions operate in parallel and are independent.
- 2) The receive channel associated signalling bits and signalling multiframe alignment bit will be frozen when multiframe alignment is lost.

3) Manual re-framing of the receive basic frame alignment and signalling multiframe alignment functions can be performed at any time.

4) The transmit RAI bit will be one until basic frame alignment is established, then it will be zero.

5) E-bits can be optionally set to zero until the equipment interworking relationship is established. When this has been determined one of the following will take place:

- a) CRC-to-non-CRC operation - E-bits = 0,
- b) CRC-to-CRC operation - E-bits as per G.704 and I.431.

6) All manual re-frames and new basic frame alignment searches start after the current frame alignment signal position.

7) After basic frame alignment has been achieved, loss of frame alignment will occur any time three consecutive incorrect basic frame alignment signals are received. Loss of basic frame alignment will reset the complete framing algorithm.

8) When CRC-4 multiframing has been achieved, the primary basic frame alignment and resulting multiframe alignment will be adjusted to the basic frame alignment determined during CRC-4 synchronization. Therefore, the primary basic frame alignment will not be updated during the CRC-4 multiframing search, but will be updated when the CRC-4 multiframing search is complete.

#### Reframe

##### E1 Mode

The MT9074 will automatically force a reframe, if three consecutive frame alignment patterns or three consecutive non-frame alignment bits are in error.

##### T1 Mode

The MT9074 will automatically force a reframe if the framing bit error density exceeds the threshold programmed by control bits RS1-0 (Framing Mode Select Word page 1H, address 10H). RS1 = RS0 = 0 forces a reframe for 2 errors out of a sliding window of 4 framing bits. RS1 = 0, RS0 = 1 forces a reframe with 2 errors out of 5. RS1 = 1, RS0 = 0 forces a reframe with 2 errors out of 6. RS1 = RS0 = 1 disables the automatic reframe.

In ESF mode all framing bits are checked. In D4 mode either Ft bits only (if control bit 2 - FSI - of Framing Mode Select Register is set low) or Ft and



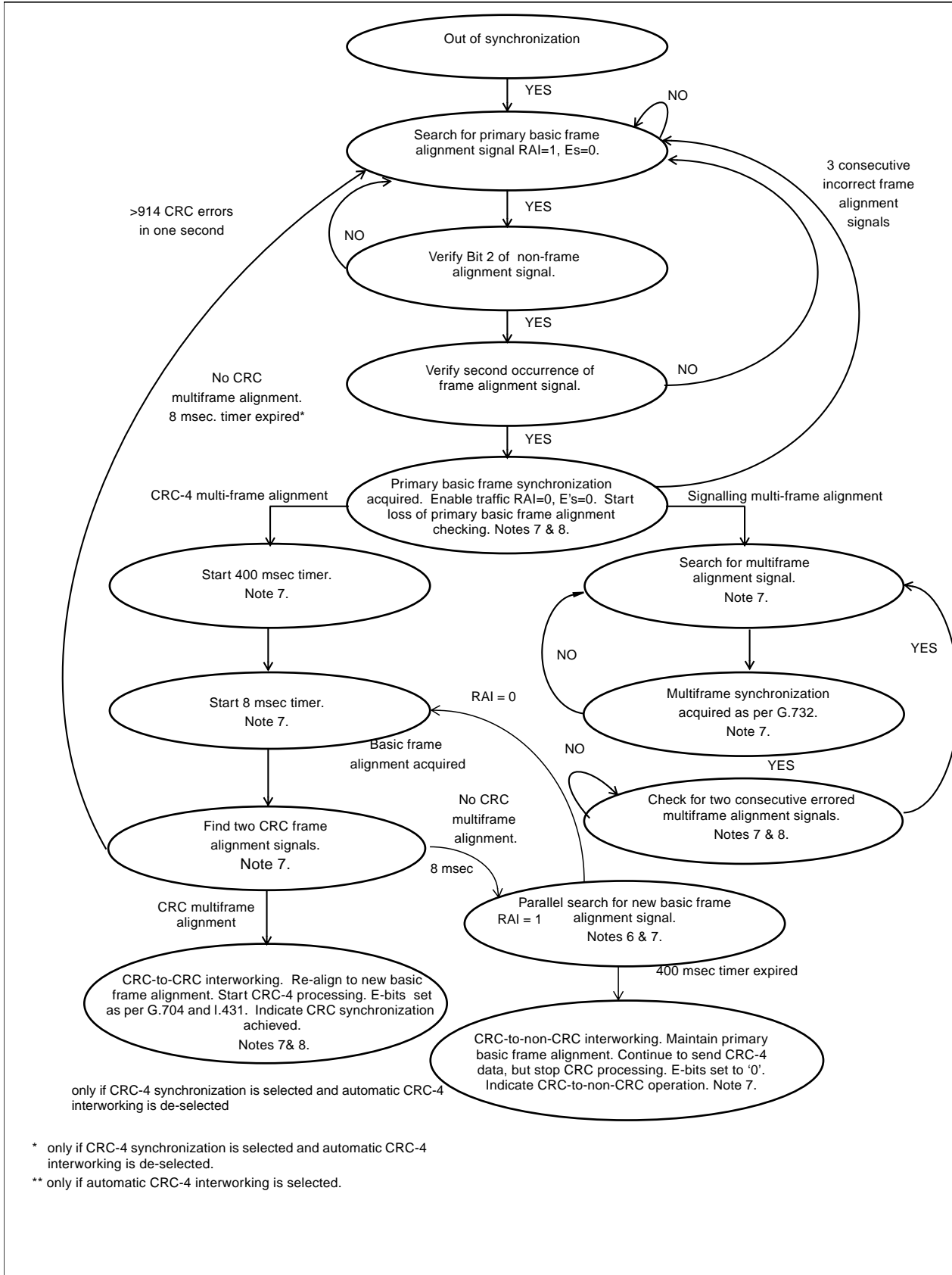

Figure 15 - Synchronization State Diagram



Fs bits are checked (FSI set high). If the D4 secondary yellow alarm is enabled (control bit 1 - D4SECY of Transmit Alarm Control Word page 1H, address 11H) then the Fs bit of frame 12 is not verified for the loss of frame circuit.

In E1 or T1 mode, receive transparent mode (selected when bit 3 page 1 address 12H is high) no reframing is forced by the device.

The user may initiate a software reframe at any time by setting bit 1, page 1, address 10H high (ReFR). Once the circuit has commenced reframing the signalling bits are frozen until multiframe synchronization has been achieved.

## MT9074 Channel Signaling

### Channel Signaling in T1 mode

In T1 mode, when control bit RBEn (page 1H, address 14H) is low the MT9074 will insert ABCD or AB signaling bits into bit 8 of every transmit DS0 channel every 6th frame. The AB or ABCD signaling bits from received frames 6 and 12 (AB) or from frames 6, 12, 18 and 24 (ABCD) will be loaded into an internal storage ram. The transmit AB/ ABCD signaling nibbles can be passed either via the micro-ports (for channels with bit 1 set high in the Per Time Slot Control Word - pages 7H and 8H) or through related channels of the CSTi serial links, see "Table 6 - STBUS vs. DS1 to Channel Relationship(T1)" on page 14. The receive signaling bits are always mapped to the equivalent ST-BUS channels on CSto. Memory pages five and six contain the transmit AB or ABCD nibbles and pages eight and nine the receive AB or ABCD nibbles for micro-port CAS access.

The serial control streams that contain the transmit / receive signaling information (CSTi and CSto respectively) are clocked at 2.048 Mhz. The number of signaling bits to be transmit / received = 24 (timeslots) x 4 bits per timeslot (ABCD) = 24 nibbles. This leaves many unused nibble positions in the 2.048 Mhz CSTi / CSto bandwidth. These unused nibble locations are tristated. The usage of the bit stream is as follows: the signaling bits are inserted / reported in the same CSTi / CSto channels that correspond to the DS1 channels used in DSTi / DSTo - see Table , "Table 6 - STBUS vs. DS1 to Channel Relationship(T1)," on page 14. The control bit MSN (Signalling Control Word, page 01H, address 14H) allows for the ABCD bit to use the most significant nibble of CSTi / CSto (MSN set high) or the least significant nibble (MSN set low). Unused nibbles and timeslots are tristate. In order to facilitate

multiplexing on the CSto control stream, an additional control bit CStoEn (Signalling Control Word, page 01H, address 14H) will tristate the whole stream when set low. This control bit is forced low with the reset pin. In the case of D4 trunks, only AB bits are reported. The control bits SM1-0 allow the user to program the 2 unused bits reported on CSto in the signalling nibble otherwise occupied by CD signalling bits in ESF trunks.

A receive signaling bit debounce of 6 msec. can be selected (DBEn set high - Signalling Control Word, page 01H, address 14H). It should be noted that there may be as much as 3 msec. added to this duration because signaling equipment state changes are not synchronous with the D4 or ESF multiframe.

If multi - frame synchronization is lost (page 3H, address 10H, bit 6  $\overline{\text{MFSYNC}} = 1$ ) all receive signalling bits are frozen. They will become unfrozen when multi - frame synchronization is acquired (this is the same as terminal frame synchronization for ESF links).

When the SIGI interrupt is unmasked,  $\overline{\text{IRQ}}$  will become active when a signalling state change is detected in any of the 24 receive channels. The SIGI interrupt mask is located on page 1, address 1EH, bit 0 (set high to enable interrupt); and the SIGI interrupt vector (page 4, address 12H) is 01H.

### Channel Signaling in E1 mode

In E1 mode, when control bit TxCCS is set to one, the MT9074 is in Common Channel Signalling (CCS) mode. When TxCCS is low it is in Channel Associated Signalling mode (CAS). The CAS mode ABCD signalling nibbles can be passed either via the micro-ports (when RPSIG = 1) or through related channels of the CSto and CSTi serial links (when RPSIG = 0). Memory page 09H and 0AH contains the receive ABCD nibbles and page 05H and 06H the transmit ABCD nibbles for micro-port CAS access.

In CAS operation an ABCD signalling bit debounce of 14 msec. can be selected by writing a one to DBNCE control bit. This is consistent with the signalling recognition time of ITU-T Q.422. It should be noted that there may be as much as 2 msec. added to this duration because signalling equipment state changes are not synchronous with the PCM 30 multiframe.

If multiframe synchronization is lost (page 03H, address 10H, when  $\overline{\text{MFSYNC}} = 1$ ) all receive CAS signalling nibbles are frozen. Receive CAS nibbles

will become unfrozen when multiframe synchronization is acquired.

When the CAS signalling interrupt is unmasked (page 01H, address 1EH, SIGI=0), pin  $\overline{IRQ}$  (pin 12 in PLCC, 85 in MQFP) will become active when a signalling nibble state change is detected in any of the 30 receive channels.

In CCS mode the data transmit on channel 16 is either sourced from channel 16 data on DSTi or from the pin CSTi. Data received from channel 16 is clocked out on CSto (pin 5 in PLCC, pin 70 in MQFP). By dividing down the extracted 2.048 MHz clock.

**Loopbacks**

In order to meet PRI Layer 1 requirements and to assist in circuit fault sectioning, the MT9074 has six loopback functions. These are as follows:

a) Digital loopback (DSTi to DSTo at the framer/LIU interface). Bit DLBK = 0 normal; DLBK = 1 activate.

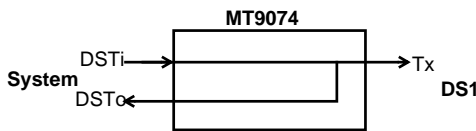

b) Remote loopback (RTIP and RRING to TTIP and TRING respectively at the DS1 side). Bit RLBK = 0 normal; RLBK = 1 activate.

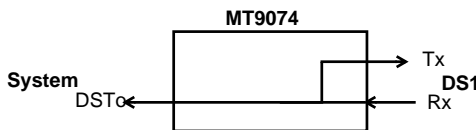

c) ST-BUS loopback (DSTi to DSTo at the system side). Bit SLBK = 0 normal; SLBK = 1 activate.

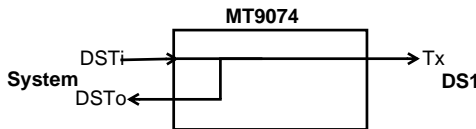

d) Payload loopback (RTIP and RRING to TTIP and TRING respectively at the system side). Bit PLBK = 0 normal; PLBK = 1 activate. The payload loopback is effectively a physical connection of DSTo to DSTi

within the MT9074. Sbit information and the DL originate at the point of loopback.

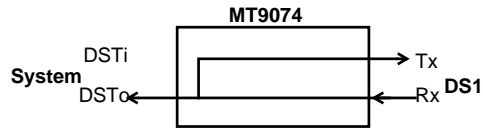

e) Metallic Loopback. MLBK = 0 normal; MLBK = 1 activate, will isolate the external signals RTIP and RRING from the receiver and internally connect the analog output TTIP and TRING to the receiver analog input.

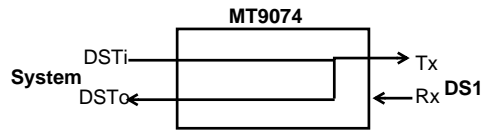

f) Local and remote time slot loopback. Remote time slot loopback control bit RTSL = 0 normal; RTSL = 1 activate, will loop around transmit ST-BUS time slots to the DSTo stream. Local time slot loopback bits LTSL = 0 normal; LTSL = 1 activate, will loop around receive PCM 30 time slots towards the remote PCM 30 end.

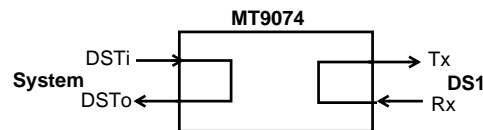

The digital, remote, ST-BUS, payload and metallic loopbacks are located on page 1, address 15H - Coding and Loopback Control Word. The remote and local time slot loopbacks are controlled through control bits 5 and 4 of the Per Time Slot Control Words, pages 7H and 8H.

**Performance Monitoring**

**Error Counters**

In T1 mode, MT9074 has eight error counters, which can be used for maintenance testing, an ongoing measure of the quality of a DS1 link and to assist the designer in meeting specifications such as TR62411 and T1.403. All counters can be preset or cleared by writing to the appropriate locations.

Associated with each counter is a maskable event occurrence interrupt and a maskable counter overflow interrupt. Overflow interrupts are useful when cumulative error counts are being recorded. For example, every time the framing bit error counter overflow interrupt (FERO) occurs, 256 frame errors have been received since the last FERO (page 04H, address 1DH) interrupt. All counters are cleared and held low by programming the counter clear bit - CNTCLR - high (bit 4 of the Reset Control Word, page 1H, address 1AH). An alternative approach to event reporting is to mask error events and to enable the 1 second sample bit (SAMPLE - bit 3 of the Reset Control Word). When this bit is set the counters for change of frame alignment, loss of frame alignment, bpv errors, crc errors, errored framing bits, and multiframe out of sync are updated on one second intervals coincident with the maskable one second interrupt timer.

In E1 mode, MT9074 has six error counters, which can be used for maintenance testing, an ongoing measure of the quality of a PCM 30 link and to assist the designer in meeting specifications such as ITU-T I.431 and G.821. All counters can be preset or cleared by writing to the appropriate locations.

Associated with each counter is a maskable event occurrence interrupt and a maskable counter overflow interrupt. Overflow interrupts are useful when cumulative error counts are being recorded. For example, every time the frame error counter overflow (FERO) interrupt occurs, 256 frame errors have been received since the last FERO interrupt. All counters are cleared and held low by programming the counter clear bit (master control page 01H, address 1A, bit 4) high. Counter overflows set bits in the counter overflow latch (page 04H, address 1FH); this latch is cleared when read.

The overflow reporting latch (page 04H, address 1FH) contains a register whose bits are set when individual counters overflow. These bits stay high until the register is read.

## T1 Counters

### Framing Bit Error Counter (FC7-0)

This eight bit counter counts errors in the framing pattern. In ESF mode any error in the 001011 framing pattern increments the counter. In SLC-96 mode any error in the Ft bit position is counted. In D4 mode Ft errors are always counted, Fs bits (except for the Sbit in frame 12) may optionally be counted (if control bit FSI is set high - page 1H, address 10H, bit 2). The counter is located on page 4H, address 13H.

There are two maskable interrupts associated with the Framing bit error measurement. A single error may generate an interrupt (enable by setting FERI high - bit 7 of the Interrupt Mask Word One, page 1H, address 1CH). A counter overflow interrupt may be enabled by setting control bit FEOM high - bit 2 of Interrupt Mask Word Two (page 1H, address 1DH).

### Out Of Frame / Change Of Frame Alignment Counter (OOF3-0/COFA3-0)

This register space is shared by two nibbles. One is the count of out of frame events. The other independent counter is incremented when, after a resynchronization, the frame alignment has moved. This count is reported in page 4, address 13H.

There are two interrupts associated with the Change of Frame Alignment counter. A single error may generate an interrupt (enable by setting COFAI high - bit 4 of the Interrupt Mask Word One, page 1H, address 1CH). A counter overflow interrupt may be enabled by setting control bit COFAO high - bit 4 of Interrupt Mask Word Two (page 1H, address 1DH).

There is one interrupt associated with the Out of Frame counter. A counter overflow interrupt may be enabled by setting control bit OOFO high - bit 5 of Interrupt Mask Word Two (page 1H, address 1DH).

### Multiframe out of Sync Counter (MFOOF7-MFOOF0)

This eight bit counter MFOOF7 - MFOOF0 is located on page 4 address 15H, and is incremented once per multiframe (1.5 ms for D4 and 3 ms for ESF) during the time that the framer is out of terminal frame synchronization.

There is a maskable interrupt associated with the measurement. A counter overflow interrupt may be enabled by setting control bit MFOOFO high - bit 1 of Interrupt Mask Word Two (page 1H, address 1DH).

### CRC-6 Error Counter (CC15-0)

CRC-6 errors are recorded by this counter for ESF links. This 16 bit counter is located on page 4H, addresses 18H and 19H.

There are two maskable interrupts associated with the CRC error measurement. A single error may generate an interrupt (enable by setting CRCI high - bit 6 of the Interrupt Mask Word One, page 1H, address 1CH). A counter overflow interrupt may be enabled by setting control bit CRCO high - bit 6 of Interrupt Mask Word Two (page 1H, address 1DH).

Bipolar Violation Error Counter (BPV15-BPV0)

The bipolar violation error counter will count bipolar violations or encoding errors that are not part of B8ZS encoding. This counter BPV15-BPV0 is 16 bits long (page 4H, addresses 16H and 17H) and is incremented once for every BPV error received. It should be noted that when presetting or clearing the BPV error counter, the least significant BPV counter address should be written to before the most significant location.

There are two maskable interrupts associated with the bipolar violation error measurement. A single error may generate an interrupt (enable by setting BPVI high - bit 3 of the Interrupt Mask Word One, page 1H, address 1CH). A counter overflow interrupt may be enabled by setting control bit BPVO high - bit 3 of Interrupt Mask Word Two (page 1H, address 1DH).

PRBS Error Counter (PS7-0)

There are two 8 bit counters associated with PRBS comparison; one for errors and one for time. Any errors that are detected in the receive PRBS will increment the PRBS Error Rate Counter of page 04H, address 10H. Writes to this counter will clear an 8 bit counter, PSM7-0 (page 01H, address 11H) which counts receive CRC multiframes. A maskable PRBS counter overflow (PRBSO) interrupt (page 1, address 1DH) is associated with this counter.

CRC Multiframe Counter for PRBS (PSM7-0)

This eight bit counter counts receive CRC-4 multiframes. It can be directly loaded via the microport. The counter will also be automatically cleared in the event that the PRBS error counter is written to by the microport. This counter is located on page 04H, address 11H.

**E1 Counters**Errored FAS Counter (EFAS7-EFAS0)

An eight bit Frame Alignment Signal Error counter EFAS7 - EFAS0 is located on page 04H address 13H, and is incremented once for every receive frame alignment signal that contains one or more errors.

There are two maskable interrupts associated with the frame alignment signal error measurement. FER1 (page 01H, address 1CH) is initiated when the least significant bit of the errored frame alignment signal counter toggles, and FER0 (page 01H, address 1DH) is initiated when the counter changes from FFH to 00H.

E-bit Counter (EC9-0)

E-bit errors are counted by the MT9074 in order to support compliance with ITU-T requirements. This ten bit counter is located on page 04H, addresses 14H and 15H respectively. It is incremented by single error events, with a maximum rate of twice per CRC-4 multiframe.

There are two maskable interrupts associated with the E-bit error measurement. EBI (page 1, address 1CH) is initiated when the least significant bit of the counter toggles, and FEBEO (page 01H, address 1DH) is initiated when the counter overflows.

Bipolar Violation Error Counter (BPV15-BPV0)

The bipolar violation error counter will count bipolar violations or encoding errors that are not part of HDB3 encoding in E1 mode. This counter BPV15-BPV0 is 16 bits long (page 4H, addresses 16H and 17H) and is incremented once for every BPV error received. It should be noted that when presetting or clearing the BPV error counter, the least significant BPV counter address should be written to before the most significant location.

In E1 mode, there are two maskable interrupts associated with the bipolar violation error measurement. BPVI (page 01H, address 1CH) is initiated when the least significant bit of the BPV error counter toggles. BPVO (page 01H, address 1DH) is initiated when the counter changes from FFFFH to 0000H.

CRC-4 Error Counter (CC9-0)

CRC-4 errors are counted by the MT9074 in order to support compliance with ITU-T requirements. This ten bit counter is located on page 04H, addresses 18H and 19H in E1 mode. It is incremented by single error events, which is a maximum rate of twice per CRC-4 multiframe.

There is a maskable interrupt associated with the CRC error measurement. CRCIM (page 01H, address 1CH) is initiated when the least significant bit of the counter toggles, and CRCOM (page 01H, address 1DH) is initiated when the counter overflows.

PRBS Error Counter (PS7-0)

There are two 8 bit counters associated with PRBS comparison; one for errors and one for time. Any errors that are detected in the receive PRBS will increment the PRBS Error Rate Counter of page 04H, address 10H. Writes to this counter will clear an 8 bit counter, PSM7-0 (page 01H, address 11H) which counts receive CRC multiframes. A maskable

PRBS counter overflow (PRBSO) interrupt (page 1, address 1DH) is associated with this counter.

CRC Multiframe Counter for PRBS (PSM7-0)

This eight bit counter counts receive CRC-4 multiframes. It can be directly loaded via the microport. The counter will also be automatically cleared in the event that the PRBS error counter is written to by the microport. This counter is located on page 04H, address 11H.

**Error Insertion**

In T1 mode MT9074 has six types of error conditions can be inserted into the transmit DS1 data stream through control bits, which are located on page 1, address 19H - Error Insertion Word. These error events include the bipolar violation errors (BPVE), CRC-6 errors (CRCE), Ft errors (FTE), Fs errors (FSE), payload (PERR) and a loss of signal condition (LOSE). The LOSE function overrides the B8ZS encoding function.

In E1 mode MT9074 has six types of error conditions can be inserted into the transmit PCM 30 data stream through control bits, which are located on page 01H, address 19H. These error events include the bipolar violation errors (BPVE), CRC-4 errors (CRCE), FAS errors (FASE), NFAS errors (NFSE), payload (PERR) and a loss of signal error (LOSE). The LOSE function overrides the HDB3 encoding function.

**Per Time Slot Control Words**

There are two per time slot control pages (addresses AH and BH) (T1/E1) occupying a total of 24 unique addresses in T1 mode or a total of 32 unique addresses in E1 mode. Each address controls a matching timeslot on the 24 DS1 channels (T1) or 32 PCM-30 channels (E1) and the equivalent channel data on the receive (DSTo) data. For example address 0 of the first per time slot control page contains program control for transmit timeslot 0 and DSTo channel 0.

Per Time Slot Control Word

Bit 7 Bit 0

T1 Mode

TXMSG	PCI	RTSL	LTSL	TTST	RRST	RPSIG	CC
-------	-----	------	------	------	------	-------	----

E1 Mode

TXMSG	ADI	RTSL	LTSL	TTST	RRST	RPSIG	---
-------	-----	------	------	------	------	-------	-----

**Clear Channel Capability**

In T1 mode when bit zero (CC) in the per time slot control word is set no bit robbing for the purpose of signalling will occur in this channel. This bit is not used in E1 mode.

**Microport Signalling**

When bit one (RPSIG) is set, the transmit signalling for the addressed channel can only be programmed by writing to the transmit signalling page (pages 5H and 6H) via the microport. If zero, the transmit signalling information is constantly updated with the information from the equivalent channel on CSTi.

**Per Time Slot Looping**

Any channel or combination of channels may be looped from transmit (sourced from DSTi) to receive (output on DSTo) STBUS channels. When bit four (LTSL) in the Per Time Slot Control Word is set the data from the equivalent transmit timeslot is looped back onto the equivalent receive channel.

Any channel or combination of channels may be looped from receive (sourced from the line data) to transmit (output onto the line) channels. When bit five (RTSL) in the Per Time Slot Control Word is set the data from the equivalent receive timeslot is looped back onto the equivalent transmit channel.

**PRBS Testing**

If the control bit ADSEQ is zero (from master control page 1 - access control word), any channel or combination of transmit channels may be programmed to contain a generated pseudo random bit sequence ( $2^{15} - 1$ ). The channels are selected by setting bit three (TTST), in the per time slot control word.

If the control bit ADSEQ is zero, any combination of receive channels may be connected to the PRBS decoder ( $2^{15} - 1$ ). Each error in the incoming sequence causes the PRBS error counter to increment. The receive channels are selected by setting bit 2 (RRST) in the per time slot control word.

If PRBS is performed during a metallic or external looparound, per time slot control words with TTST set should have RRST set as well.



**Digital Milliwatt**

If the control bit ADSEQ is one, a digital milliwatt sequence (Table 18) in T1 mode or (Table 19) in E1 mode may be transmit on any combination of selected channels. The channels are selected by setting bit three (TTST), in the Per Time Slot Control Word.

Under the same control condition (ADSEQ equal to one), the same digital milliwatt sequence is available to replace received data on any combination of DSTo channels. This is accomplished by setting bit two (RRST) in the Per Time Slot Control Word for the corresponding channel.

Bit 1	Bit 2	Bit 3	Bit 4	Bit 5	Bit 6	Bit 7	Bit 8
0	0	0	1	1	1	1	0
0	0	0	0	1	0	1	1
0	0	0	0	1	0	1	1
0	0	0	1	1	1	1	0
1	0	0	1	1	1	1	0
1	0	0	0	1	0	1	1
1	0	0	0	1	0	1	1
1	0	0	1	1	1	1	0

Table 18 - Digital Milliwatt Pattern (T1)

Bit 1	Bit 2	Bit 3	Bit 4	Bit 5	Bit 6	Bit 7	Bit 8
0	0	1	1	0	1	0	0
0	0	1	0	0	0	0	1
0	0	1	0	0	0	0	1
0	0	1	1	0	1	0	0
1	0	1	1	0	1	0	0
1	0	1	0	0	0	0	1
1	0	1	0	0	0	0	1
1	0	1	1	0	1	0	0

Table 19 - A-Law Digital Milliwatt Pattern (E1)

**Per Channel Inversion**

When bit six (PCI) in the Per Time Slot Control Word is set both transmit and receive data for the selected channel is inverted before going onto the line / DSTo respectively.

**Transmit Message**

When bit seven (TXMSG) in the Per Time Slot Control Word is set the data transmit in the selected

channel is sourced from the transmit message word in Master Control page 1.

**Alarms**

The following alarms are detected by the receiver in T1 mode. Each may generate a maskable interrupt:

- Yellow alarm - in D4 mode there are two possible yellow alarm signals. If control bit D4SECY is set low, (page 1H, address 11Hb it 1) the criteria for a yellow alarm is an excess of '0's (more than 285) in bit position 2 of incoming DS0 channels during an integration period of 1.5 milliseconds. It is cleared after more than 3 '1's are detected in bit position 2 of normal data in a 1.5 millisecond integration period. If D4SECY is set high the secondary yellow alarm is selected. The detection criteria becomes 2 consecutive '1's in the Sbit position of the 12th frame. In ESF mode the alarm is set if the pattern 0000000111111111 is received in seven or more codewords out of ten.;
- All Ones - This bit (page 3H, address 11H, bit 3) is set if less than six zeros are received on the incoming line data during a 3 ms interval
- Loss of Signal - a loss of signal condition occurs when the receive signal level is lower than 40 dB below the nominal signal level for at least a millisecond or when 192 consecutive zeros have been received. A loss of signal condition will terminate when than average ones density of at least 12.5% has been received over a period of 193 contiguous pulse positions starting with a pulse. The loss of signal is reported in the Receive Signal Status Word - page 3, address 16H bit 4.

The following alarms are detected by the receiver in E1 mode. Each may generate a maskable interrupt:

- Remote Alarm Indication (RAI) - bit 3 (A) of the receive NFAS;
- Alarm Indication Signal (AIS) - unframed all ones signal for at least a double frame (512 bits) or two double frames (1024 bits);
- Channel 16 Alarm Indication Signal - all ones signal in channel 16;
- Auxiliary pattern - 101010... pattern for at least 512 bits;
- Loss of Signal - a loss of signal condition occurs when the receive signal level is lower than 20dB or 40 dB (by setting the bit ELOS on page 2) below the nominal signal level for



more than a millisecond or when more than 192 zeros have been received in a row. A loss of signal condition will terminate when an average ones density of at least 12.5% has been received over a period of 255 contiguous pulse positions starting with a pulse.

- Remote Signalling Multiframe Alarm - (Y-bit) of the multiframe alignment signal.

The alarm reporting latch (address 12H page 04H) contains a register whose bits are set high for selected alarms. These bits stay high until the register is read. This allows the controller to record intermittent or sporadic alarm occurrences.

### Automatic Alarms

In E1 mode the transmission of RAI and signalling multiframe alarms can be made to function automatically from control bits ARAI and AUTY (page 01H, address 10H). When ARAI = 0 and basic frame synchronization is lost ( $\overline{\text{SYNC}} = 1$ ), the MT9074 will automatically transmit the RAI alarm signal to the far end of the link. The transmission of this alarm signal will cease when basic frame alignment is acquired.

When AUTY = 0 and signalling multiframe alignment is not acquired ( $\overline{\text{MFSYNC}} = 1$ ), the MT9074 will automatically transmit the multiframe alarm (Y-bit) signal to the far end of the link. This transmission will cease when signalling multiframe alignment is acquired.

### Detected Events and Words

#### T1 mode

##### Severely Errored Frame Event

In T1 mode bit 5 page 3H address 10H toggles whenever a sliding window detects 2 framing errors events (Ft or ESF) in a sliding window of 6.

##### Loop Code Detect

T1.403 defines SF mode line loopback activate and deactivate codes. These codes are either a framed or un-framed repeating bit sequence of 00001 for activation or 001 for deactivation. The standard goes on to say that these codes will persist for five seconds or more before the loopback action is taken. In T1 mode MT9074 will detect both framed and unframed line activate and de-activate codes even in the presence of a BER of  $3 \times 10^{-3}$ . Line Loopback Disable Detect - LLDD - in the Alarm Status Word

(bit 0 address 11H of page 3H) will be asserted when a repeating 001 pattern (either framed or unframed) has persisted for 48 milliseconds. Line Loopback Enable Detect LLED in the Alarm Status Word will be asserted when a repeating 00001 pattern (either framed or unframed) has persisted for 48 milliseconds.

##### Pulse Density Violation Detect

In T1 mode bit 2 of address 11H on page 3H (PDV) toggles if the receive data fails to meet ones density requirements. It will toggle upon detection of 16 consecutive zeros on the line data, or if there are less than N ones in a window of  $8(N+1)$  bits - where  $N = 1$  to 23.

##### Timer Outputs

In T1 mode MT9074 has a one second timer derived from the 20 Mhz oscillator pins. The timer may be used to trigger interrupts for T1.403/408 performance messaging.

#### E1 mode

##### Consecutive Frame Alignment Patterns (CONFAP)

Two consecutive frame alignment signals in error.

##### Receive Frame Alignment Signals

These bits are received on the PCM 30 and link in bit positions two to eight of time slot 0 - frame alignment signal. These signals form the frame alignment signal and should be 0011011.

##### Receive Non Frame Alignment Signal

This signal is received on the PCM 30 and link in bit position two of time slot 0 - non frame alignment signal.

##### Receive Multiframe Alignment Signals

These signal are received on the PCM 30 and link in bit position one to four of time slot 16 of frame zero of every signalling multiframe.

### Interrupts

The MT9074 has an extensive suite of maskable interrupts, which are divided into four categories based on the type of event that caused the interrupt. Each interrupt has an associated mask and interrupt bit. When an unmasked interrupt event occurs,  $\overline{\text{IRQ}}$  will go low and one or more bits of the appropriate interrupt register will go high. After each interrupt register is read it is automatically cleared. When all

interrupt registers are cleared  $\overline{IRQ}$  will return to a high impedance state. This function can also be accomplished by toggling the INTA bit (page 1, address 1AH).

All the interrupts of the MT9074 in T1 and E1 mode are maskable. This is accomplished through interrupt mask words zero to three, which are located on page 1, addresses 1BH to 1EH and the (optional) HDLC interrupt mask located at address 16 of page B.

After a MT9074 reset ( $\overline{RESET}$  pin or RST control bit), all interrupts are masked.

All interrupts may be suspended, without changing the interrupt mask words, by making the SPND control bit of page 1, address 1AH high.

All interrupts are cleared by forcing the pin  $\overline{TxAO}$  low.

**Interrupts on T1 mode**

Interrupt Mask Word Zero

Bit 7							Bit 0
TFSYNI	MFSYNI	TSAI	AISI	LOSI	SEI	TxSLPI	RxSLPI

Interrupt Mask Word One

Bit 7							Bit 0
FEI	CRCI	YELI	COFAI	BPVI	PRBSI	PDVI	---

Interrupt Mask Word Two

Bit 7							Bit 0
FEO	CRCO	OOF0	COFAO	BPVO	PRBSO	MFOOFO	---

Interrupt Mask Word Three

Bit 7							Bit 0
---	---	---	LCDI	1SECI	5SECI	BIOMI	SIGI

HDLC Interrupt Masks

Bit 7							Bit 0
Ga	EOPD	TEOP	EopR	TxFI	FATxU	RxFf	RxOv

**Interrupts on E1 mode**

Interrupt Mask Word Zero

Bit 7							Bit 0
SYNI	MFSYI	CSYNI	AISI	LOSI	CEFI	YI	SLPI

Interrupt Mask Word One

Bit 7							Bit 0
FERI	CRCI	EBI	AIS16I	BPVI	PRBSI	AUXPI	RAII

Interrupt Mask Word Two

Bit 7							Bit 0
FEOM	CRCO	EBOI	---	BPVO	PRBSO	PRBSMO	---

Interrupt Mask Word Three

Bit 7							Bit 0
---	---	---	JAI	1SECI	5SECI	RCRI	SIGI

HDLC Interrupt Masks

Bit 7							Bit 0
Ga	EOPD	TEOP	EopR	TxFI	FATxU	RxFf	RxOv

## Digital Framer Mode

### T1 mode

Setting bit 4 in the Configuration Control Word (address 10H of Master Control Page 2) disables the LIU and converts the MT9074 into a digital T1 transceiver. The digital 2.048 Mb/s ST-BUS backplane maps into transmit and receive digital 1.544 Mb/s streams. The 1.544 Mb/s transmit streams may be formatted for single phase NRZ (by setting bit 7 of the LIU Control Word - Master Page 1 high) or two phase NRZ. The data rate conversion (between 2.048 Mb/s and 1.544 Mb/s) is done within the MT9074. The transmit 1.544 MHz clock is internally generated from a PLL that locks onto the input C4b clock. This clock is then output on pin E1.5o (PLCC pin 44 - QFP pin 32). The digital 1.544 Mb/s transmit data is output on pins TXA and TXB (PLCC pins 37,38 - QFP pins 18,19) with the rising edge of C1.5o. Receive digital data is clocked in on pins RRING and RTIP. This data is clocked in with the rising edge of the input 1.544 Mhz clock S/FR/E1.5i (PLCC pin 66, QFP pin 63). Coding is optional under software control.

### E1 mode

Setting bit 4 in the Configuration Control Word (address 10H of Master Control Page 2) disables the LIU and converts the MT9074 into a digital E1 transceiver. The digital 2.048 Mb/s ST-BUS backplane maps into transmit and receive digital 2.048 Mb/s streams. The 2.048 Mb/s transmit data streams may be formatted for single phase NRZ (by setting bit 7 of the LIU Control Word - Master Page 1 high) or two phase NRZ. The transmit 2.048 MHz clock is derived from the input C4b clock. This clock is then output on pin E1.5o (PLCC pin 44 - QFP pin 32). The digital 2.048 Mb/s transmit data is output on pins TXA and TXB (PLCC pins 37,38 - QFP pins 18,19) with the rising edge of E1.5o. Receive digital data is clocked in on pins RRING and RTIP. This data is clocked in with the rising edge of the input 2.048 Mhz clock MS/FR/E1.5i (PLCC pin 66, QFP pin 63). Coding is optional under software control.

Control and Status Registers

T1 Mode

Master Control 1 (Page 01H) (T1)

Address (A <sub>4</sub> A <sub>3</sub> A <sub>2</sub> A <sub>1</sub> A <sub>0</sub> )	Register	Function
10H (Table 21)	Framing Mode Select	ESF, SCL96, CXC, RS1-0, FSI, ReFR, MFRReFR
11H (Table 22)	Transmit Alarm Control Word	ESFYEL, TXSECY, D4YEL, $\overline{\text{TxAO}}$ , LUA, LDA, D4SECY, SO
12H (Table 23)	Data Link Control Word	EDL, BIOMEn, HDLC0, HDLC1, TxSYNC, TRSP,JT, H1R64
13H (Table 24)	Transmit Bit Oriented Message	BIOMTx7-0
14H (Table 25)	Signalling Control Word	DSToEn, CSToEn, RBEEn, DBEn, MSN, SM1-0, JYEL
15H (Table 26)	Coding and Loopback Control Word	RxB8ZS, MLBK,TxB8ZS,FBS, DLBK, RLBK, SLBK, PLBK
16H (Table 27)	Reserved	Set all bits to zero for normal operation
17H (Table 28)	Transmit Elastic buffer Set Delay Word	TxTSD7-0
18H (Table 29)	Transmit Message Word	TXM7-0
19H (Table 30)	Error Insertion Word	BPVE, CRCE, FTE, FSE, LOSE, PERR, LOS/LOF
1AH (Table 31)	Reset Control Word	RST, SPND, INTA, CNTCLR, SAMPLE, EXTOSC
1BH (Table 32)	Interrupt Mask Word Zero	TFSYNIM, MFSYNIM, AISIM, LOSIM, SEIM, TxSLPIM, RxSLPIM
1CH (Table 33)	Interrupt Mask Word One	FEIM, CRCIM, YELIM, COFAIM, BPVIM, PRBSIM, PDVIM
1DH (Table 34)	Interrupt Mask Word Two	FEOM, CRCOM, OOFOM, COFAOM, BPVOM, PRBSOM, PRBSMFOM,MFOOFOM
1EH (Table 35)	Interrupt Mask Word Three	LCDIM, 1SECIM, 5SECIM, BIOIM, SIGIM
1FH (Table 36)	LIU Control Word	NRZ, TxL2-0, REDBL, RES2-0

Table 20 - Master Control 1 (Page 1) (T1)

Bit	Name	Functional Description
7	ESF	<b>Extended Super Frame.</b> Setting this bit enables transmission and reception of the 24 frame superframe DS1 protocol.
6	SLC96	<b>SLC96 Mode Select.</b> Setting this bit enables input and output of the Fs bit pattern on the TxDL and RxDL pins. Frame synchronization is the same as in the case of D4 operation. The transmitter will insert A and B bits every 6 frames after synchronizing to the Fs pattern clocked into Txdl. Receive Fs bits are not monitored for the Framing Bit Error Counter.
5	CXC	<b>Cross Check.</b> Setting this bit in ESF mode enables a cross check of the CRC-6 remainder before the frame synchronizer pulls into sync. This process adds at least 6 milliseconds to the frame synchronization time. Setting this bit in D4 (not ESF) mode enables a check of the Fs bits in addition to the Ft bits during frame synchronization
4 - 3	RS1-0	<b>Reframe Select 1 - 0.</b> These bits set the criteria for an automatic reframe in the event of framing bits errors. The combinations available are: RS1 - 0, RS0 - 0 = sliding window of 2 errors out of 4. RS1 - 0, RS0 - 1 = sliding window of 2 errors out of 5. RS1 - 1, RS0 - 0 = sliding window of 2 errors out of 6. RS1 - 1, RS0 - 1 = no reframes due to framing bit errors.

**Table 21 - Framing Mode Select (T1)  
(Page 1, Address 10H)**

Bit	Name	Functional Description
2	FSI	<b>Fs Bit Include.</b> Only applicable in D4 mode (not ESF or SLC96). Setting this bit causes errored Fs bits to be included as framing bit errors. A bad Fs bit will increment the Framing Error Bit Counter, and will potentially cause a reframe (if it is the second bad framing bit out of 5). The Fs bit of the receive frame 12 will only be included if D4SECY is set low.
1	ReFR	<b>Reframe.</b> Setting this bit causes an automatic reframe.
0	MFRReFR	<b>MultiFrame Reframe.</b> Only applicable in D4 or SLC96 mode. Setting this bit causes an automatic multiframe reframe. The signalling bits are frozen until multiframe synchronization is achieved. Terminal frame synchronization is not affected.

**Table 21 - Framing Mode Select (T1)  
(Page 1, Address 10H)**

Bit	Name	Functional Description
7	ESFYEL	<b>ESFYellow Alarm.</b> Setting this bit while in ESF mode causes a repeating pattern of eight 1's followed by eight 0's to be insert onto the transmit FDL (JTS bit set low - see Data Link Control Word) or sixteen 1's (Japan Telecom bit set high).
6	TXSECY	<b>Transmit Secondary D4 Yellow Alarm.</b> Setting this bit (in D4 mode) causes the S bit of transmit frame 12 to be set.
5	D4YEL	<b>D4 Yellow Alarm.</b> When set bit 2 of all DS0 channels are forced low.
4	TxAO	<b>Transmit All Ones.</b> When low, this control bit forces a framed or unframed (depending on the state of Transmit Alarm Control bit 0) all ones to be transmit at TTIP and TRING.
3	LUA	<b>Loop Up Activate.</b> Setting this bit forces transmission of a framed or unframed (depending on the state of Transmit Alarm Control bit 0) repeating pattern of 00001.
2	LDA	<b>Loop Down Activate.</b> Setting this bit forces transmission of a framed or unframed (depending on the state of Transmit Alarm Control bit 0) repeating pattern of 001.
1	D4SECY	<b>D4 Secondary Alarm.</b> Set this bit for trunks employing the secondary Yellow Alarm. The Fs bit in the 12th frame will not be used for counting errored framing bits. If a one is received in the Fs bit position of the 12th frame a Secondary Yellow Alarm Detect bit will be set.
0	SO	<b>Overhead Sbits Override.</b> If set, this bit forces the overhead bits to be inserted as an overlay on any of the following alarm conditions: i) transmit all ones, ii) loop up code insertion, iii) loop down code insertion.

**Table 22 - Transmit Alarm Control Word (T1)  
(Page 1, Address 11H)**

Bit	Name	Functional Description
7	EDL	<b>Enable Data Link.</b> Setting this bit multiplexes the serial stream clocked in on pin TxDL into the FDL bit position (ESF mode) or the Fs position (D4 mode).
6	BIOMEn	<b>Bit Oriented Messaging Enable.</b> Setting this bit enables transmission of bit - oriented messages on the ESF facility data link. The actual message transmit at any one time is contained in the BIOMTx register (page 1, address 13H). The receive bit - oriented message register is always active, although the interrupt associated with it may be masked.
5	HDLC0	<b>HDLC0 Enable.</b> Setting this bit selects the internal HDLC controller for transmission of data link information in the FDL Sbits of an ESF frame. The HDLC receiver is always active, although interrupts associated with it may be masked.
4	HDLC1	<b>HDLC1 Enable.</b> Setting this bit selects the internal HDLC controller for transmission on DS1 channel 24. The HDLC receiver is always active, although interrupts associated with it may be masked.
3	TxSYNC	<b>Transmit Synchronization.</b> Setting this bit causes the transmit multiframe boundary to be internally synchronized to the incoming Sbits on DSTi channel 31 bit 0.
2	TRSP	<b>Transparent Mode.</b> Setting this bit causes unframed data to be transmit from DSTi channels 0 to 23 and channel 31 bit 7 to be transmit transparently onto the DS1 line. Unframed data received from the DS1 line is piped out on DSTo channels 0 to 23 and channel 31 bit 0.

**Table 23 - Data Link Control Word (T1)  
(Page 1, Address 12H)**



Bit	Name	Functional Description
1	JTS	<b>Japan Telecom Synchronization.</b> Setting this bit forces the inclusion of Sbits in the CRC-6 calculation.
0	H1R64	<b>HDLC1 Rate Select.</b> Setting this pin high while HDLC1 is activated enables 64 Kb/s operation of the data link on channel 24. Setting this pin low while HDLC1 is activated enables 56 Kb/s operation on channel 24 (this prevents data corruption due to forced bit stuffing).

**Table 23 - Data Link Control Word (T1)  
(Page 1, Address 12H)**

Bit	Name	Functional Description
7 - 0	BIOMTx7-0	<b>Transmit Bit Oriented Message.</b> The contents of this register are concatenated with a sequence of eight 1's and continuously transmit in the FDL bit position of ESF trunks. Normally the leading bit (bit 7) and last bit (bit 0) of this register are set to zero.

**Table 24 - Transmit Bit Oriented Message (T1)  
(Page 1, Address 13H)**

Bit	Name	Functional Description
7	DSToEn	<b>DSTo Enable.</b> If zero pin DSTo is tristate. If set the pin DSTo is enabled.
6	CSToEn	<b>CSTo Enable.</b> If zero pin CSTo is tristate. If set the pin CSTo is enabled.
5	RBEn	<b>Robbed Bit Signalling Enable.</b> Setting this bit multiplexes the AB or ABCD signalling bits into bit position 8 of all DS0 channels every 6th frame.
4	DBEn	<b>Debounce Enable.</b> Setting this bit causes incoming signalling bits to be debounced for a period of 6 to 9 milliseconds before reporting on CSTo or in the Receive Signalling Bits Page.
3	MSN	<b>Most Significant Nibble.</b> If set to one the most significant nibble of CSTi and CSTo are activated. The reporting stream CSTo contains signalling information for the equivalent channel in the most significant nibble, and least significant nibble is tristate. If set to zero the least significant nibble is active for CSTi and CSTo and the most significant nibble of CSTo is tristate.
2-1	SM1-0	<b>Signalling Message.</b> These two bits are used to fill the vacant bit positions available on CSTo when the MT9074 is operating on a D4 trunk. The first two bits of each reporting nibble of CSTo contain the AB signalling bits. The last two contain SM1 and SM0 (in that order). When the MT9074 is connected to ESF trunks four signalling bits (ABCD) are reported and bits SM1-0 become unused.
0	JYEL	<b>Japan Yellow Alarm.</b> Set this bit high to select a pattern of 16 ones (1111111111111111) as the ESF yellow alarm, both for the case when and ESF yellow alarm is to be transmitted or in recognizing a received yellow alarm.

**Table 25 - Signalling Control Word (T1)  
(Page 1, Address 14H)**

Bit	Name	Functional Description
7	RxB8ZS	<b>Receive B8ZS Enable.</b> If one, receive B8ZS decoding is enabled.
6	MLBK	<b>Metallic Loopback.</b> If one, then RRTIP/RRING are connected directly to TTIP and TRING respectively. If zero, this feature is disabled. Set the transmit line build out to -7.5dB when metallic loopback is enabled.
5	TxB8ZS	<b>Transmit B8ZS Enable.</b> If one, all zero octets are substituted with B8ZS codes.
4	FBS	<b>Forced Bit Stuffing.</b> If set any transmit DS0 channel containing all zeros has bit 7 forced high.
3	DLBK	<b>Digital Loopback.</b> If one, the digital stream to the transmit LIU is looped back in place of the digital output of the receive LIU. Data coming out of DSTo will be a delayed version of DSTi. If zero, this feature is disabled.
2	RLBK	<b>Remote Loopback.</b> If one, all time slots received on RRTIP/RRING are connected to TTIP/TRING on the DS1 side of the MT9074. If zero, this feature is disabled.
1	SLBK	<b>ST-BUS Loopback.</b> If one, all time slots of DSTi are connected to DSTo on the ST-BUS side of the MT9074. If zero, this feature is disabled. See Loopbacks section.

**Table 26 - Coding and Loopback Control Word (T1)(Page 1, Address 15H)**

Bit	Name	Functional Description
0	PLBK	<b>Payload Loopback.</b> If one, all time slots received on RTIP/RRING are connected to TTIP/TRING on the ST-BUS side of the MT9074. If zero, this feature is disabled. If receive robbed bit signaling data is to be included in the looped data, then the control bit RBEn (Page 1 Address 14H, Bit 5) must be set low, otherwise transmit signaling data will be placed into the LSB of each timeslot every sixth frame. Setting all Clear Channel control bits high (Bit 0 in the Per Time Slot Control words - Pages 7 and 8 Address 10H to 1FH inclusive) has the same effect as setting control bit RBEn low.

**Table 26 - Coding and Loopback Control Word (T1)(Page 1, Address 15H)**

Bit	Name	Functional Description
7-0	---	Unused

**Table 27 - Reserved (T1) (Page 1, Address 16H)**

Bit	Name	Functional Description
7-0	TxSD7-0	<b>Transmit Set Delay Bits 7-0.</b> Writing to this register forces a one time setting of the delay through the transmit slip buffer. Delay is defined as the time interval between the write of the transmit STBUS channel containing DS1 timeslot 1 and its subsequent read. Delay is modified by moving the position of the internally generated DS1 frame boundary. Delay (when set) will always be less than 1 frame (125uS). This register must be programmed with a non-zero value (such as 0FH).

**Table 28 - Transmit Elastic Buffer Set Delay Word (T1) (Page 1, Address 17H)**

Bit	Name	Functional Description
7-0	TxM7-0	<b>Transmit Message Bits 7 - 0.</b> The contents of this register are transmitted into those outgoing DS1 channels selected by the Per Time Slot Control registers.

**Table 29 - Transmit Message Word (T1)  
(Page 1, Address 18H)**

Bit	Name	Functional Description
7	BPVE	<b>Bipolar Violation Error Insertion.</b> A zero-to-one transition of this bit inserts a single bipolar violation error into the transmit DS1 data. A one, zero or one-to-zero transition has no function.
6	CRCE	<b>CRC-6 Error Insertion.</b> A zero-to-one transition of this bit inserts a single CRC-6 error into the transmit ESF DS1 data. A one, zero or one-to-zero transition has no function.
5	FTE	<b>Terminal Framing Bit Error Insertion.</b> A zero-to-one transition of this bit inserts a single error into the transmit D4 Ft pattern or the transmit ESF framing bit pattern (in ESF mode). A one, zero or one-to-zero transition has no function.
4	FSE	<b>Signal Framing Bit Error Insertion.</b> A zero-to-one transition of this bit inserts a single error into the transmit Fs bits (in D4 mode only). A one, zero or one-to-zero transition has no function.
3	LOSE	<b>Loss of Signal Error Insertion.</b> If one, the MT9074 transmits an all zeros signal (no pulses). Zero code suppression is overridden. If zero, data is transmitted normally.
2	PERR	<b>Payload Error Insertion.</b> A zero - to - one transition of this bit inserts a single bit error in the transmit payload. A one, zero or one-to-zero transition has no function.

**Table 30 - Error Insertion Word (T1)  
(Page 1, Address 19H)**

Bit	Name	Functional Description
1	---	<b>Unused.</b>
0	LOS/ LOF	<b>Loss of Signal or Loss of Frame Selection.</b> If one, pin LOS will go high when a loss of signal state exists (criteria as per LLOS status bit). If low, pin LOS will go high when either a loss of signal or a loss of frame alignment state exists.

**Table 30 - Error Insertion Word (T1)  
(Page 1, Address 19H)**

Bit	Name	Functional Description
7	RST	<b>Software reset.</b> Setting this bit is equivalent to performing a hardware reset. All counters are cleared and the control registers are set to their default values. This control bit is internally cleared after the reset operation is complete.
6	SPND	<b>Suspend Interrupts.</b> If one, the $\overline{\text{IRQ}}$ output will be in a high-impedance state and all interrupts will be ignored. If zero, the $\overline{\text{IRQ}}$ output will function normally.
5	INTA	<b>Interrupt Acknowledge.</b> Setting this bit clears all the interrupt status bits and forces the $\overline{\text{IRQ}}$ pin into high impedance. The control bit itself is then internally cleared.
4	CNTCLR	<b>Counter Clear.</b> If one, all status error counters are cleared and held low.
3	SAMPLE	<b>One Second Sample.</b> Setting this bit causes the error counters (change of frame alignment, loss of frame alignment, bpv errors, crc errors, severely errored frame events and multiframes out of sync) to be updated on one second intervals coincident with the one second timer (status page 3 address 12H bit 7).

**Table 31 - Reset Control Word (T1)  
(Page 1, Address 1AH)**

Bit	Name	Functional Description
2	EXTOSC	<b>External Oscillator Select.</b> Setting this bit connects the pin OSC1 to a TTL compatible input. This allows for a system design employing a TTL output oscillator as a 20.000 Mhz reference clock.
1	RSV	<b>Reserved.</b> Set to zero for normal operation.
0	RSV	<b>Reserved.</b> Set to zero for normal operation.

**Table 31 - Reset Control Word (T1)**  
(Page 1, Address 1AH)

Bit	Name	Functional Description
7	TFSYNIM	<b>Terminal Frame Synchronization Interrupt Mask.</b> When unmasked an interrupt is initiated whenever a change of state of terminal frame synchronization condition exists. If 1 - unmasked, 0 - masked.
6	MFSYNIM	<b>Multiframe Synchronization Interrupt Mask.</b> When unmasked an interrupt is initiated whenever a change of state of multiframe synchronization condition exist. If 1 - unmasked, 0 - masked.
5	---	<b>Unused.</b>
4	AISIM	<b>Alarm Indication Signal Interrupt Mask.</b> When unmasked a change of state of received all ones condition will initiate an interrupt. If 1 - unmasked, 0 - masked.
3	LOSIM	<b>Loss of Signal Interrupt Mask.</b> When unmasked an interrupt is initiated whenever a change of state of loss of signal condition exists. If 1 - unmasked, 0 - masked. Interrupt vector = 01000000.

**Table 32 - Interrupt Mask Word Zero (T1)**  
(Page 1, Address 1BH)

Bit	Name	Functional Description
2	SEFIM	<b>Severely Errored Frame Interrupt Mask.</b> When unmasked an interrupt is initiated when a sequence of 2 framing errors out of 6 occurs. If 1 - unmasked, 0 - masked.
1	TxSLPIM	<b>Transmit SLIP Interrupt Mask.</b> When unmasked an interrupt is initiated whenever a controlled frame slip occurs in the transmit elastic buffer. If 1 - unmasked, 0 - masked.
0	RxSLPIM	<b>Receive SLIP Interrupt Mask.</b> When unmasked an interrupt is initiated whenever a controlled frame slip occurs in the receive elastic buffer. If 1 - unmasked, 0 - masked.

**Table 32 - Interrupt Mask Word Zero (T1)**  
(Page 1, Address 1BH)

Bit	Name	Functional Description
7	FEIM	<b>Framing Bit Error Interrupt Mask.</b> When unmasked an interrupt is initiated whenever an erroneous framing bit is detected (provided the circuit is in terminal frame sync). If 1 - unmasked, 0 - masked.
6	CRCIM	<b>CRC-6 Error Interrupt Mask.</b> When unmasked an interrupt is initiated whenever a local CRC-6 error occurs. If 1 - unmasked, 0 - masked.
5	YELIM	<b>Yellow Alarm Interrupt Mask.</b> When unmasked detection of a yellow alarm triggers an interrupt. If 1 - unmasked, 0 - masked.
4	COFAIM	<b>Change of Frame Alignment Interrupt Mask.</b> When unmasked an interrupt is initiated whenever a change of frame alignment occurs after a reframe. If 1 - unmasked, 0 - masked.

**Table 33 - Interrupt Mask Word One (T1)**  
(Page 1, Address 1CH)

Bit	Name	Functional Description
3	BPVIM	<b>Bipolar Violation Interrupt Mask.</b> When unmasked an interrupt is initiated whenever a bipolar violation (excluding B8ZS encoding) is encountered. If 1 - unmasked, 0 - masked.
2	PRBSIM	<b>Pseudo Random Bit Sequence Error Interrupt Mask.</b> When unmasked an interrupt will be generated upon detection of an error with a channel selected for PRBS testing. 1 - unmasked, 0 - masked.
1	PDVIM	<b>Pulse Density Violation Interrupt Mask.</b> When unmasked an interrupt is triggered whenever a sequence of excessive consecutive zeros is received on the line, or the incoming pulse density is less than N ones in a time frame of 8(N+1) where N = 1 to 23. If 1 - unmasked, 0 - masked.
0	---	<b>Unused.</b>

**Table 33 - Interrupt Mask Word One (T1)  
(Page 1, Address 1CH)**

Bit	Name	Functional Description
7	FEOM	<b>Framing Bit Error Counter Overflow Interrupt Mask.</b> When unmasked an interrupt is initiated whenever the framing bit error counter changes from FFH to 00H. If 1 - unmasked, 0 - masked.
6	CRCOM	<b>CRC-6 Error Counter Overflow Interrupt Mask.</b> When unmasked an interrupt is initiated whenever the CRC-6 error counter changes from FFH to 00H. If 1 - unmasked, 0 - masked.

**Table 34 - Interrupt Mask Word Two (T1)  
(Page 1, Address 1DH)**

Bit	Name	Functional Description
5	OOFOM	<b>Out Of Frame Counter Overflow Interrupt Mask.</b> When unmasked an interrupt is initiated whenever the out of frame counter changes state from changes from FFH to 00H. If 1 - unmasked, 0 - masked.
4	COFAOM	<b>Change of Frame Alignment Counter Overflow Interrupt Mask.</b> When unmasked an interrupt is initiated whenever the change of frame alignment counter changes from FFH to 00H. If 1 - unmasked, 0 - masked.
3	BPVOM	<b>Bipolar Violation Counter Overflow Interrupt Mask.</b> When unmasked an interrupt is initiated whenever the bipolar violation counter changes from FFH to 00H. If 1 - unmasked, 0 - masked.
2	PRBSOM	<b>Pseudo Random Bit Sequence Error Counter Overflow Interrupt Mask.</b> When unmasked an interrupt will be generated whenever the PRBS error counter changes from FFH to 00H. If 1 - unmasked, 0 - masked.
1	PRBSMFOM	<b>Pseudo Random Bit Sequence Multiframe Counter Overflow Interrupt Mask.</b> When unmasked an interrupt will be generated whenever the multiframe counter attached to the PRBS error counter overflows. FFH to 00H. If 1 - unmasked, 0 - masked.
0	MFOOFOM	<b>Multiframes Out Of Sync Overflow Interrupt Mask.</b> When unmasked an interrupt will be generated when the multiframe out of frame counter changes from FFH to 00H. If 1 - unmasked, 0 - masked.

**Table 34 - Interrupt Mask Word Two (T1)  
(Page 1, Address 1DH)**

Bit	Name	Functional Description
7-5	- - -	<b>Unused.</b>
4	LCDIM	<b>Loop Code Detected Interrupt Mask.</b> When unmasked an interrupt is triggered when either the loop up (00001) or loop down (001) code has been detected on the line for a period of 48 milliseconds. If 1 - unmasked, 0 - masked.
3	1SECIM	<b>One Second Status Interrupt Mask.</b> When unmasked an interrupt is initiated when the 1SEC status bit (page 3 address 12H bit 7) goes from low to high. If 1 - unmasked, 0 - masked.
2	5SECIM	<b>Five Second Status Interrupt Mask.</b> When unmasked an interrupt is initiated when the 5 SEC status bit goes from low to high. If 1 - unmasked, 0 - masked.
1	BIOMIM	<b>Bit Oriented Message Interrupt Mask.</b> When unmasked an interrupt is initiated when a pattern 111111110xxxxx0 has been received on the FDL that is different from the last message. The new message must persist for 8 out the last 10 message positions to be accepted as a valid new message. If 1 - unmasked, 0 - masked.
0	SIGIM	<b>Signalling Interrupt Mask.</b> When unmasked an interrupt will be initiated when a change of state (optionally debounced - see DBEn in the Data Link, Signalling Control Word page 1 address 12H) is detected in the signalling bits (AB or ABCD) pattern. If 1 - unmasked, 0 - masked.

**Table 35 - Interrupt Mask Word Three (T1)  
(Page 1, Address 1EH)**

Bit	Name	Functional Description
7	NRZ	<b>NRZ Format Selection.</b> Only used in the digital framer only mode (LIU is disabled). A one sets the MT9074 to accept a unipolar NRZ format input stream on RxA as the line input, and to transmit a unipolar NRZ format stream on TxB. A zero causes the MT9074 to accept a complementary pair of dual rail inputs on RxA/RxB and to transmit a complementary pair of dual rail outputs on TxA/TxB.
6 - 4	TXL2-0	<b>Transmit Line Build Out 2 - 0.</b> Setting these bits shapes the transmit pulse as detailed in the table below: TX22 TXL1 TXL0 Line Build Out 0 0 0 0 to 133 feet/ 0 dB 0 0 1 133 to 266 feet 0 1 0 266 to 399 feet 0 1 1 399 to 533 feet 1 0 0 533 to 655 feet 1 0 1 -7.5 dB 1 1 0 -15 dB 1 1 1 -22.5 dB After reset these bits are zero.
3	REDBL	<b>Receive Equalizer Disable.</b> If one the receive equalizer is turned off. If zero, the receive equalizer is turned on and will compensate for loop length automatically.
2-0	RES2-0	<b>Receive Equalization Select.</b> Setting these pins forces a level of equalization of the incoming line data. RES2 RES1 RES0 Receive Equalization 0 0 0 none 0 0 1 6dB 0 1 0 12dB 0 1 1 18dB 1 0 0 24dB 1 0 1 reserved 1 1 0 reserved 1 1 1 reserved These settings have no effect if REDBL is set to zero.

**Table 36 - LIU Control Word (T1)  
(Page 1, Address 1FH)**



## Master Control 2 (Page 02H) (T1)

Address (A <sub>4</sub> A <sub>3</sub> A <sub>2</sub> A <sub>1</sub> A <sub>0</sub> )	Register	Names
10H (Table 38)	Configuration Control Word	T1/E1, $\overline{\text{LIUE}}\overline{\text{n}}$ , ADSEQ
11H (Table 39)	Custom Tx Pulse Enable	CPL
12H	Reserved	Set all bits to zero for normal operation.
13H	Reserved	Set all bits to zero for normal operation.
14H	Reserved	Set all bits to zero for normal operation.
15H	Reserved	Set all bits to zero for normal operation.
16H	Reserved	Set all bits to zero for normal operation.
17H	Reserved	Set all bits to zero for normal operation.
18H	Reserved	Set all bits to zero for normal operation.
19H	Reserved	Set all bits to zero for normal operation.
1AH	Reserved	Set all bits to zero for normal operation.
1BH	Reserved	Set all bits to zero for normal operation.
1CH (Table 40)	Custom Pulse Word 1	CP6-0
1DH (Table 41)	Custom Pulse Word 2	CP6-0
1EH (Table 42)	Custom Pulse Word 3	CP6-0
1FH (Table 43)	Custom Pulse Word 4	CP6-0

Table 37 - Master Control 2 (Page 02H) (T1)

Bit	Name	Functional Description
7	T1/E1	<b>T1/E1 mode selection.</b> when this bit is zero, the device is in T1 mode. When set high, the device is in E1 mode.
6-5	RSV	<b>Reserved.</b> Must be kept at 0 for normal operation.
4	LIUEn	<b>LIU Enable.</b> Setting this bit low enables the internal LIU front-end. Setting this pin high disables the LIU. Digital inputs RXA and RXB are sampled by the rising edge of E1.5i (C1.50) to strobe in the received line data. Digital transmit data is clocked out of pins TXA and TXB with the rising edge of C1.5o
3-2	RSV	<b>Reserved.</b> Must be kept at 0 for normal operation.
1	ADSEQ	<b>Digital Milliwatt or Digital Test Sequence.</b> If one, the Alaw digital milliwatt analog test sequence will be selected for those channels with per time slot control bits TTST, RRST set. If zero, a PRBS generator / detector will be connected to channels with TTST, RRST respectively.
0	RSV	<b>Reserved.</b> Must be kept at 0 for normal operation.

**Table 38 - Configuration Control Word (Page 2, Address 10H) (T1)**

Bit	Name	Functional Description
7	RSV	<b>Reserved.</b> Must be kept high for normal operation.
6-4	RSV	<b>Reserved.</b> Must be kept low for normal operation.
3	CPL	<b>Custom Pulse Level.</b> Setting this bit low enables the internal ROM values in generating the transmit pulses. The ROM is coded for different line terminations or build out, as specified in the LIU Control word. Setting this bit high disables the pre-programmed pulse templates. Each of the 4 phases that generate a mark derive their D/A coefficients from the values programmed in the CPW registers.
2-0	RSV	<b>Reserved.</b> Must be kept at 0 for normal operation.

**Table 39 - Custom Tx Pulse Enable (Page 2, Address 11H) (T1)**

Bit	Name	Functional Description
7	RSV	<b>Reserved.</b> Must be kept low for normal operation.
6-0	CP6-0	<b>Custom Pulse.</b> These bits provide the capability for programming the magnitude setting for the TTIP/TRING line driver A/D converter during the first phase of a mark. The greater the binary number loaded into the register, the greater the amplitude driven out. This feature is enabled when the control bit 3 - CPL of the Custom Tx Pulse Enable Register - address 11H of Page 2 is set high.

**Table 40 - Custom Pulse Word 1 (Page 2, Address 1CH) (T1)**

Bit	Name	Functional Description
7	RSV	<b>Reserved.</b> Must be kept at 0 for normal operation.
6-0	CP6-0	<b>Custom Pulse.</b> These bits provide the capability for programming the magnitude setting for the TTIP/TRING line driver A/D converter during the second phase of a mark. The greater the binary number loaded into the register, the greater the amplitude driven out. This feature is enabled when the control bit 3 - CPL of the Custom Tx Pulse Enable Register - address 11H of Page 2 is set high.

**Table 41 - Custom Pulse Word 2  
(Page 2, Address 1DH) (T1)**

Bit	Name	Functional Description
7	RSV	<b>Reserved.</b> Must be kept at 0 for normal operation.
6-0	CP6-0	<b>Custom Pulse.</b> These bits provide the capability for programming the magnitude setting for the TTIP/TRING line driver A/D converter during the fourth phase of a mark. The greater the binary number loaded into the register, the greater the amplitude driven out. This feature is enabled when the control bit 3 - CPL of the Custom Tx Pulse Enable Register - address 11H of Page 2 is set high.

**Table 43 - Custom Pulse Word 4  
(Page 2, Address 1FH) (T1)**

Bit	Name	Functional Description
7	RSV	<b>Reserved.</b> Must be kept at 0 for normal operation.
6-0	CP6-0	<b>Custom Pulse.</b> These bits provide the capability for programming the magnitude setting for the TTIP/TRING line driver A/D converter during the third phase of a mark. The greater the binary number loaded into the register, the greater the amplitude driven out. This feature is enabled when the control bit 3 - CPL of the Custom Tx Pulse Enable Register - address 11H of Page 2 is set high.

**Table 42 - Custom Pulse Word 3  
(Page 2, Address 1EH) (T1)**

**Master Status 1 (Page03H) (T1)**

<b>Address (A<sub>4</sub>A<sub>3</sub>A<sub>2</sub>A<sub>1</sub>A<sub>0</sub>)</b>	<b>Register</b>	<b>Function</b>
10H (Table 45)	Synchronization Status Word	$\overline{TFSYNC}$ , $\overline{MFSYNC}$ , SE, LOS
11H (Table 46)	Alarm Status Word	D4YALM, D4Y48, SECYEL, ESFYEL, BLUE, PDV, LLED, LLDD
12H (Table 47)	Timer Status Word	1SEC, 2SEC, 5SEC
13H (Table 48)	Most Significant Phase Status Word	RSLIP, RSLPD, RxFRM
14H (Table 49)	Least Significant Phase Status Word	RxTS4-0, RxBC2-0
15H (Table 50)	Receive Bit Oriented Message	RxBOM7-0
16H (Table 51)	Receive Signal Status Word	PD4-PD0, LLOS
17H (Table 52)	MSB Transmit Slip Buffer	TSLIP, TSLPD, TxSBMSB
18H (Table 53)	Transmit Slip Buffer Delay	TxTS4-0, TxBC2-0
19H	---	Unused.
1AH	---	Unused.
1BH - 1EH	---	Unused.
1FH (Table 54)	Identification Register	Internally set to 10101111

**Table 44 - Master Status 1 (Page 3) (T1)**

Bit	Name	Functional Description
7	$\overline{\text{TFSYNC}}$	<b>Terminal Frame Synchronization.</b> Indicates the Terminal Frame Synchronization status (1 - loss; 0 - acquired). For ESF links terminal frame synchronization and multiframe synchronization are synonymous.
6	$\overline{\text{MFSYN}}\overline{\text{C}}$	<b>Multiframe Synchronization.</b> Indicates the Multiframe Synchronization status (1 - loss; 0 - acquired). For ESF links multiframe synchronization and terminal frame synchronization are synonymous.
5	SE	<b>Severely Errored Frame.</b> This bit toggles when 2 of the last 6 received framing bits are in error. The framing bits monitored are the ESF framing bits for ESF links, the Ft bits for SLC-96 links and a combination of Ft and Fs bits for D4 links (See Framing Mode Selection Word - page 1 address 10H).
4	LOS	<b>Digital Los Of Signal.</b> This bit goes high after the detection of 192 consecutive zeros. It returns low when the incoming pulse density exceeds 12.5% over a 250 ms period
3 - 0	---	<b>Unused.</b>

Table 45 - Synchronization Status Word (Page 3, Address 10H) (T1)

Bit	Name	Functional Description
7	D4YALM	<b>D4 Yellow Alarm.</b> This bit is set if bit position 2 of virtually every DS0 channel is a zero for a period of 600 milliseconds. The alarm is tolerant of errors by permitting up to 16 ones in a 48 millisecond integration period. The alarm clears in 200 milliseconds after being removed from the line.

Table 46 - Alarm Status Word (Page 3, Address 11H) (T1)

Bit	Name	Functional Description
6	D4Y48	<b>D4 Yellow Alarm - 48 millisecond sample.</b> This bit is set if bit position 2 of virtually every DS0 channel is a zero for a period of 48 milliseconds. The alarm is tolerant of errors by permitting up to 16 ones in the integration period. This bit is updated every 48 milliseconds.
5	SECYEL	<b>Secondary D4 Yellow Alarm.</b> This bit is set if 2 consecutive '1's are received in the Sbit position of the 12th frame of the D4 superframe.
4	ESFYEL	<b>ESF Yellow Alarm.</b> This bit sets if the ESF yellow alarm 0000000011111111 is received in seven or more codewords out of ten.
3	BLUE	<b>Blue Alarm.</b> This bit is set if less than 6 zeros are received in a 3 millisecond window.
2	PDV	<b>Pulse Density Violation.</b> This bit toggles if RxB8ZS is set high, it will toggle upon detection of 8 consecutive zeros. If RxB8ZS is set low, it will toggle upon detection of 16 consecutive zeros on the line data, or if there are less than N ones in a window of 8(N+1) bits - where N=1 to 23.
1	LLED	<b>Line Loopback Enable Detect.</b> This bit will be set when a framed or unframed repeating pattern of 00001 has been detected during a 48 millisecond interval. Up to fifteen errors are permitted per integration period.
0	LLDD	<b>Line Loopback Disable Detect.</b> This bit will be set when a framed or unframed repeating pattern of 001 has been detected during a 48 millisecond interval. Up to fifteen errors are permitted per integration period.

Table 46 - Alarm Status Word (Page 3, Address 11H) (T1)

Bit	Name	Functional Description
7	1SEC	<b>One Second Timer Status.</b> This bit changes state once every 0.5 seconds.
6	2SEC	<b>Two Second Timer Status.</b> This bit changes state once every second and is synchronous with the 1SEC timer.
5	5SEC	<b>Five Second Timer Status.</b> This bit changes state once every 2.5 seconds and is synchronous with the 1SEC timer.
4-0	---	<b>Unused.</b>

**Table 47 - Timer Status Word (Page 3, Address 12H) (T1)**

Bit	Name	Functional Description
7	RSLIP	<b>Receive Slip.</b> A change of state (i.e., 1-to-0 or 0-to-1) indicates that a receive controlled frame slip has occurred.
6	RSLPD	<b>Receive Slip Direction.</b> If one, indicates that the last received frame slip resulted in a repeated frame, i.e., the system clock (C4b) is faster than network clock (E2o). If zero, indicates that the last received frame slip resulted in a lost frame, i.e., system clock slower than network clock. Updated on an RSLIP occurrence basis.
5	RxFRM	<b>Receive Frame Delay.</b> The most significant bit of the Receive Slip Buffer Phase Status Word. If zero, the delay through the receive elastic buffer is greater than one frame in length; if one, the delay through the receive elastic buffer is less than one frame in length.
4-0	---	<b>Unused</b>

**Table 48 - Most Significant Phase Status Word (Page 3, Address 13H) (T1)**

Bit	Name	Functional Description
7 - 3	RxTS4 - 0	<b>Receive Time Slot.</b> A five bit counter that indicates the number of time slots between the receive elastic buffer internal write frame boundary and the ST-BUS read frame boundary. The count is updated every 250 uS.
2 - 0	RxBC2 - 0	<b>Receive Bit Count.</b> A three bit counter that indicates the number of STBUS bit times there are between the receive elastic buffer internal write frame boundary and the ST-BUS read frame boundary. The count is updated every 250 uS.

**Table 49 - Least Significant Phase Status Word (Page 3, Address 14H) (T1)**

Bit	Name	Functional Description
7 - 0	RxBOM7 - 0	<b>Received Bit Oriented Message.</b> This register contains the eight least significant bits of the ESF bit oriented message codeword. The contents of this register is updated when a new bit - oriented message codeword has been detected in 8 out of the last ten codeword positions.

**Table 50 - Receive Bit Oriented Message (Page 3, Address 15H) (T1)**



Bit	Name	Functional Description																																				
7 - 3	PD4 - PD0	<p><b>Peak Detector Voltage Levels.</b> These five bits indicate the level of the received signal AMI pulses.</p> <table border="1"> <thead> <tr> <th>PD4</th> <th>PD3</th> <th>PD2</th> <th>PD1</th> <th>PD0</th> <th>Line Attenuation</th> </tr> </thead> <tbody> <tr> <td>0</td> <td>0</td> <td>0</td> <td>0</td> <td>1</td> <td>less than 4dB</td> </tr> <tr> <td>0</td> <td>0</td> <td>0</td> <td>1</td> <td>0</td> <td>3-8dB</td> </tr> <tr> <td>0</td> <td>0</td> <td>1</td> <td>0</td> <td>0</td> <td>8-14dB</td> </tr> <tr> <td>0</td> <td>1</td> <td>0</td> <td>0</td> <td>0</td> <td>14-20dB</td> </tr> <tr> <td>1</td> <td>0</td> <td>0</td> <td>0</td> <td>0</td> <td>more than 20dB</td> </tr> </tbody> </table>	PD4	PD3	PD2	PD1	PD0	Line Attenuation	0	0	0	0	1	less than 4dB	0	0	0	1	0	3-8dB	0	0	1	0	0	8-14dB	0	1	0	0	0	14-20dB	1	0	0	0	0	more than 20dB
PD4	PD3	PD2	PD1	PD0	Line Attenuation																																	
0	0	0	0	1	less than 4dB																																	
0	0	0	1	0	3-8dB																																	
0	0	1	0	0	8-14dB																																	
0	1	0	0	0	14-20dB																																	
1	0	0	0	0	more than 20dB																																	
2	LLOS	<p><b>LIU Loss of Signal indication.</b> This bit will be high when the received signal is less than 40 dB below the nominal value for a period of at least 1 msec. This bit will be low for normal operation.</p>																																				
1-0	---	Unused																																				

Table 51 - Receive Signal Status Word (Page 3, Address 16H) (T1)

Bit	Name	Functional Description
7 - 3	TxTS4 - 0	<p><b>Transmit Time Slot.</b> A five bit counter that indicates the number of STBUS time slots between the transmit elastic buffer STBUS write frame boundary and the internal transmit read frame boundary. The count is updated every 250 uS.</p>
2 - 0	TxBC2 - 0	<p><b>Transmit Bit Count.</b> A three bit counter indicating the number of STBUS bit times there are between the transmit elastic buffer STBUS write frame boundary and the internal read frame boundary. The count is updated every 250 uS.</p>

Table 53 - Transmit Slip Buffer Delay (Page 3, Address 18H) (T1)

Bit	Name	Functional Description
7	TSLIP	<p><b>Transmit Slip.</b> A change of state (i.e. 1-to-0 or 0-to-1) indicates that a transmit controlled frame slip has occurred.</p>
6	TSLPD	<p><b>Transmit Slip Direction.</b> If one, indicates that the last transmit frame slip resulted in a repeated frame, i.e., the internally generated 1.544 Mhz. transmit clock is faster than the system clock (C4b). If zero, indicates that the last transmit frame slip resulted in a lost frame, i.e., the internally generated 1.544 Mhz. transmit clock is slower than network clock. Updated on an TSLIP occurrence basis.</p>
5	TxSB MSB	<p><b>Transmit Slip Buffer MSB.</b> The most significant bit of the phase status word. If one, delay through the transmit elastic buffer is greater than one frame in length; if zero, delay through the receive elastic buffer is less than one frame in length. Bit is reset whenever page 3 address 17H - Transmit Slip Buffer Delay - is written to.</p>
4 - 0	---	Unused.

Table 52 - MSB Transmit Slip Buffer (Page 3, Address 17H) (T1)

Bit	Name	Functional Description
7-0	ID7-0	<p><b>ID Number.</b> Contains device code 10101111</p>

Table 54 - Identification Word (Page 3, Address 1FH) (T1)

**Master Status 2 (Page04H)(T1)**

<b>Address (A<sub>4</sub>A<sub>3</sub>A<sub>2</sub>A<sub>1</sub>A<sub>0</sub>)</b>	<b>Register</b>	<b>Function</b>
10H (Table 56)	PRBS Error Counter	PS7-0
11H (Table 57)	CRC Multiframe counter for PRBS	PSM7-0
12H (Table 58)	Alarm Reporting Latch	D4YALML, D4Y48L, SECYELL, ESFYELL, BLUEL, PDVL, LLEDL, LLDDL
13H (Table 59)	Framing Bit Counter	FC7-0
14H (Table 60)	Out of Frame / Change of Frame Alignment Counters	OOF3-0/COFA3-0
15H (Table 61)	Multiframes Out of Sync Counter	MFOOF7-0
16H (Table 62)	Most Significant Bipolar Violation Error Counter	BPV15 - BPV8
17H (Table 63)	Least Significant Bipolar Violation Error Counter	BPV7 - BPV0
18H (Table 64)	CRC- 6 Error Counter CEt	CC15-CC8
19H (Table 65)	CRC- 6 Error Counter CEt	CC7 - CC0
1AH		Unused.
1BH (Table 66)	Interrupt Word Zero	TFSYNI, MFSYNI, AISI, LOSI, SEI, TxSLPI, RxSLPI
1CH (Table 67)	Interrupt Word One	FEI, CRCI, YELI, COFAI, BPVI, PRBSI, PDVI
1DH (Table 68)	Interrupt Word Two	FEO, CRCO, OOFO, COFAO, BPVO, PRBSO, PRBSMFO, MFOOFO
1EH (Table 69)	Interrupt Word Three	HDLC0I, HDLC1I, LCDI, 1SECI, 5SECI, BIOMI, SIGI
1FH (Table 70)	Overflow Reporting Latch	FEOL, CRCOL, OOFOL, COFAOL, BPVOL, PRBSOL, MFOOFOL

**Table 55 - Master Status 2 (Page 4) (T1)**

Bit	Name	Functional Description
7 - 0	PS7-0	This counter is incremented for each PRBS error detected on any of the receive channels connected to the PRBS error detector.

**Table 56 - PRBS Error Counter  
(Page 4, Address 10H) (T1)**

Bit	Name	Functional Description
7 - 0	PSM7-0	This counter is incremented for each received CRC multiframe. It is cleared when the PRBS Error Counter is written to.

**Table 57 - CRC Multiframe Counter for PRBS  
(Page 4, Address 11H) (T1)**

Bit	Name	Functional Description
7	D4YALML	<b>D4 Yellow Alarm Latch.</b> This bit is set if a D4 yellow alarm is detected within a 600 millisecond integration period. It is cleared after a read.
6	D4Y48L	<b>D4 Yellow Alarm (48 milliseconds) Latch.</b> This bit is set if a D4 yellow alarm is detected within a 48 millisecond integration period. It is cleared after a read.
5	SECYELL	<b>Secondary D4 Yellow Alarm Latch.</b> This bit is set if an alternate D4 (S bit in 12 <sup>th</sup> frame) is detected. It is cleared after a read.
4	ESFYELL	<b>ESF Yellow Alarm Latch.</b> This bit is set upon receipt of a ESF yellow alarm. It is cleared after a read.
3	BLUEL	<b>Blue Alarm Latch.</b> This bit is set upon receipt of a blue alarm. It is cleared after a read.
2	PDVL	<b>Pulse Density Violation Latch.</b> This bit is set upon receipt of a pulse density violation. It is cleared after a read.
1	LLEDL	<b>Line Loopback Enable Detect Latch.</b> This bit is set upon receipt of a line loopback enable code. It is cleared after a read.
0	LLDDL	<b>Line Loopback Disable Detect Latch.</b> This bit is set upon receipt of a line loopback disable code. It is cleared after a read.

**Table 58 - Alarm Reporting Latch  
(Page 4, Address 12H) (T1)**

Bit	Name	Functional Description
7 - 0	FC7 - 0	<b>Framing Bit Counter.</b> This eight bit counter will be incremented for each error in the received framing pattern. In ESF mode the ESF framing bits are monitored. In D4 mode Fs bits may be monitored as well as Ft bits. See - Section 15.5 Framing Bit Counter. The count is only active if the MT9074 is in synchronization.

**Table 59 - Framing Bit Counter  
(Page 4, Address 13H) (T1)**

Bit	Name	Functional Description
7 - 4	OOF3 - 0	<b>Out Of Frame Counter.</b> This four bit counter is incremented with every loss of receive frame synchronization.
3 - 0	COFA3 - 0	<b>Change of Frame Alignment Counter.</b> This four bit counter is incremented if a resynchronization is done which results in a shift in the frame alignment position.

**Table 60 - Out Of Frame / Change of Frame Alignment Counter  
(Page 4, Address 14H) (T1)**

Bit	Name	Functional Description
7 - 0	MFOO F7 - 0	<b>Multiframes Out of Synchronization Counter.</b> This eight bit counter will be incremented once for every multiframe (1.5 milliseconds in D4 mode, 3 milliseconds in ESF mode) in which basic frame synchronization is lost.

**Table 61 - Multiframes Out of Sync Counter  
(Page 4, Address 15H) (T1)**

Bit	Name	Functional Description
7 - 0	BPV15 - 8	<b>Most Significant Bits of the BPV Counter.</b> The most significant eight bits of a 16 bit counter that is incremented once for every bipolar violation error received.

**Table 62 - Most Significant Bits of the BPV Counter  
(Page 4, Address 16H) (T1)**

Bit	Name	Functional Description
7 - 0	BPV7 - 0	<b>Least Significant Bits of the BPV Counter.</b> The least significant eight bits of a 16 bit counter that is incremented once for every bipolar violation error received.

**Table 63 - Least Significant Bits of the BPV Counter  
(Page 4, Address 17H) (T1)**

Bit	Name	Functional Description
7 - 0	CC15 - 8	<b>CRC-6 Error Counter Bits Fifteen to Eight.</b> These are the most significant eight bits of the CRC-6 error counter.

**Table 64 - CRC-6 Error Counter  
(Page 4, Address 18H) (T1)**

Bit	Name	Functional Description
7 - 0	CC7 - 0	<b>CRC-6 Error Counter Bits Seven to Zero.</b> These are the least significant eight bits of the CRC-6 error counter.

**Table 65 - CRC-6 Error Counter  
(Page 4, Address 19H) (T1)**

Bit	Name	Functional Description
7	TFSYNI	<b>Terminal Frame Synchronization Interrupt.</b> When unmasked this interrupt bit goes high whenever a change of state of terminal frame synchronization condition exists. Reading this register clears this bit.
6	MFSYNI	<b>Multiframe Synchronization Interrupt.</b> When unmasked this interrupt bit goes high whenever a change of state of multiframe synchronization condition exists. Reading this register clears this bit.
5	- - -	<b>Unused.</b>
4	AISI	<b>Alarm Indication Signal Interrupt.</b> When unmasked this interrupt bit goes high whenever a change of state of received all ones condition exists. Reading this register clears this bit.
3	LOSI	<b>Loss of Signal Interrupt.</b> When unmasked this interrupt bit goes high whenever a change of state of loss of signal (either analog - signal 40 dB below nominal or digital - 192 consecutive 0's received) condition exists. Reading this register clears this bit.
2	SEI	<b>Severely Errored Frame Interrupt.</b> When unmasked this interrupt bit goes high whenever a sequence of 2 framing errors out of 6 occurs. Reading this register clears this bit.
1	TxSLPI	<b>Transmit SLIP Interrupt.</b> When unmasked this interrupt goes high whenever a controlled frame slip occurs in the transmit elastic buffer. Reading this register clears this bit.
0	RxSLPI	<b>Receive SLIP Interrupt.</b> When unmasked this interrupt bit goes high whenever a controlled frame slip occurs in the receive elastic buffer. Reading this register clears this bit.

**Table 66 - Interrupt Word Zero  
(Page 4, Address 1BH) (T1)**

Bit	Name	Functional Description
7	FEI	<b>Framing Bit Error Interrupt.</b> When unmasked this interrupt bit goes high whenever an erroneous framing bit is detected (provided the circuit is in terminal frame sync). Reading this register clears this bit.
6	CRCI	<b>CRC-6 Error Interrupt.</b> When unmasked this interrupt bit goes high whenever a local CRC-6 error occurs. Reading this register clears this bit.
5	YELI	<b>Yellow Alarm Interrupt.</b> When unmasked this interrupt bit goes high upon detection of a yellow alarm. Reading this register clears this bit.
4	COFAI	<b>Change of Frame Alignment Interrupt.</b> When unmasked this interrupt bit goes high whenever a change of frame alignment occurs after a reframe. Reading this register clears this bit.
3	BPVI	<b>Bipolar Violation Interrupt.</b> When unmasked this interrupt bit goes high whenever a bipolar violation (excluding B8ZS encoding) is encountered. Reading this register clears this bit.
2	PRBSI	<b>Pseudo Random Bit Sequence Error Interrupt.</b> When unmasked this interrupt bit goes high upon detection of an error with a channel selected for PRBS testing. Reading this register clears this bit.
1	PDVI	<b>Pulse Density Violation Interrupt.</b> When unmasked this interrupt bit goes high whenever in the absence of B8ZS coding a sequence of 16 consecutive zeros is received on the line, or the incoming pulse density is less than N ones in a time frame of 8(N+1) where N = 1 to 23. In the case of B8ZS coding, the interrupt is set upon detection of 8 consecutive zeros. Reading this register clears this bit.
0	- - -	<b>Unused.</b>

**Table 67 - Interrupt Word One  
(Page 4, Address 1CH) (T1)**

Bit	Name	Functional Description
7	FEO	<b>Framing Bit Error Counter Overflow Interrupt.</b> When unmasked this interrupt bit goes high whenever the framing bit error counter changes from FFH to 00H. Reading this register clears this bit.
6	CRCO	<b>CRC-6 Error Counter Overflow Interrupt.</b> When unmasked this interrupt bit goes high whenever the CRC-6 error counter changes from FFH to 00H. Reading this register clears this bit.
5	OOFO	<b>Out Of Frame Counter Overflow Interrupt.</b> When unmasked this interrupt bit goes high whenever the out of frame counter changes state from changes from FFH to 00H. Reading this register clears this bit.
4	COFAO	<b>Change of Frame Alignment Counter Overflow Interrupt.</b> When unmasked this interrupt bit goes high whenever the change of frame alignment counter changes from FFH to 00H. Reading this register clears this bit.
3	BPVO	<b>Bipolar Violation Counter Overflow Interrupt.</b> When unmasked this interrupt bit goes high whenever the bipolar violation counter changes from FFH to 00H. Reading this register clears this bit.
2	PRBSO	<b>Pseudo Random Bit Sequence Error Counter Overflow Interrupt.</b> When unmasked this interrupt bit goes high whenever the PRBS error counter changes from FFH to 00H. Reading this register clears this bit.

**Table 68 - Interrupt Word Two (Page 4, Address 1DH) (T1)**

Bit	Name	Functional Description
1	PRBSMFO	<b>Pseudo Random Bit Sequence Multiframe Counter Overflow Interrupt.</b> When unmasked this interrupt bit goes high whenever the multiframe counter attached to the PRBS error counter overflows. FFH to 00H. 1 - unmasked, 0 - masked.
0	MFOOFO	<b>Multiframes Out Of Sync Overflow Interrupt.</b> When unmasked this interrupt bit goes high whenever the multiframes out of frame counter changes from FFH to 00H. Reading this register clears this bit.

**Table 68 - Interrupt Word Two (Page 4, Address 1DH) (T1)**



Bit	Name	Functional Description
7	- - -	<b>Unused.</b>
6	HDLC0I	<b>HDLC0 Interrupt.</b> Whenever an unmasked HDLC0 interrupt occurs (from the 4 kHz data link) this bit goes high. Reading this register clears this bit.
5	HDLC1I	<b>HDLC1 Interrupt.</b> Whenever an unmasked HDLC1 interrupt occurs (from the DS1 channel 24 signalling channel) this bit goes high. Reading this register clears this bit.
4	LCDI	<b>Loop Code Detected Interrupt.</b> When unmasked this interrupt bit goes high whenever either the loop up (00001) or loop down (001) code has been detected on the line for a period of 48 milliseconds. Reading this register clears this bit.
3	1SECI	<b>One Second Status Interrupt.</b> When unmasked this interrupt bit goes high whenever the 1SEC status bit (page 3 address 12H bit 7) goes from low to high. Reading this register clears this bit.
2	5SECI	<b>Five Second Status Interrupt.</b> When unmasked this interrupt bit goes high whenever the 5 SEC status bit goes from low to high. Reading this register clears this bit.

**Table 69 - Interrupt Word Three  
(Page 4, Address 1EH) (T1)**

Bit	Name	Functional Description
1	BIOMI	<b>Bit Oriented Message Interrupt.</b> When unmasked this interrupt bit goes high whenever a pattern 11111110xxxxx0 has been received on the FDL that is different from the last message. The new message must persist for 8 out the last 10 message positions to be accepted as a valid new message. Reading this register clears this bit.
0	SIGI	<b>Signalling Interrupt.</b> When unmasked this interrupt bit goes high whenever a change of state (optionally debounced - see DBEn in the Data Link, Signalling Control Word page 1 address 12H) is detected in the signalling bits (AB or ABCD) pattern. Reading this register clears this bit.

**Table 69 - Interrupt Word Three  
(Page 4, Address 1EH) (T1)**

Bit	Name	Functional Description
7	FEOL	<b>Framing Bit Error Counter Overflow Latch.</b> This bit is set when the framing bit counter overflows. It is cleared after being read.
6	CRCOL	<b>CRC-6 Error Counter Overflow Latch.</b> This bit is set when the crc error counter overflows. It is cleared after being read.
5	OOFOL	<b>Out Of Frame Counter Overflow Latch.</b> This bit is set when the out of frame counter overflows. It is cleared after being read.
4	COFAOL	<b>Change of Frame Alignment Counter Overflow Latch.</b> This bit is set when the change of frame alignment counter overflows. It is cleared after being read.
3	BPVOL	<b>Bipolar Violation Counter Overflow Latch.</b> This bit is set when the bipolar violation counter overflows. It is cleared after being read.
2	PRBSOL	<b>Psuedo Random Bit Sequence Error Counter Overflow Latch.</b> This bit is set when the PRBS error counter overflows. It is cleared after being read.
1	PRBSMFOFOL	<b>Psuedo Random Bit Sequence Multiframe Counter Overflow Latch.</b> This bit is set when the multiframe counter attached to the PRBS error counter overflows. It is cleared after being read
0	MFOOFOL	<b>Multiframes Out Of Sync Overflow Latch.</b> This bit is set when the multiframes out of sync counter overflows. It is cleared after being read.

**Table 70 - Overflow Reporting Latch  
(Page 4, Address 1FH) (T1)**

**Per Channel Transmit Signalling (Pages 5 and 6) (T1)**

Page 05H, addresses 10000 to 11111, and page 06H addresses 10000 to 10111 contain the Transmit Signalling Control Words for DS1 channels 1 to 16 and 17 to 24 respectively. Table 107 illustrates the mapping between the addresses of these pages and the DS1 channel numbers. Control of these bits for any one channel is through the processor or controller port when the Per Time Slot Control bit RPSIG bit is high. Table 72 describes bit allocation within each of these registers.

Page 5-6 Address:	0	1	2	3	4	5	6	7	8	9	10	11	12	13	14	15
Equivalent DS1 channel	1	2	3	4	5	6	7	8	9	10	11	12	13	14	15	16
Page 6 Address:	0	1	2	3	4	5	6	7	8	9	10	11	12	13	14	15
Equivalent DS1 channel	17	18	19	20	21	22	23	24	x	x	x	x	x	x	x	x

**Table 71 - Page 5, 6 Address Mapping to DS1 Channels (T1)**

Bit	Name	Functional Description
7 - 4	- - -	<b>Unused.</b>
3	A(n)	<b>Transmit Signalling Bits A for Channel n.</b> Where signalling is enabled, these bits are transmitted in bit position 8 of the 6th DS1 frame (within the 12 frame superframe structure for D4 superframes and the 24 frame structure for ESF superframes).
2	B(n)	<b>Transmit Signalling Bits B for Channel n.</b> Where signalling is enabled, these bits are transmitted in bit position 8 of the 12th DS1 frame (within the 12 frame superframe structure for D4 superframes and the 24 frame structure for ESF superframes).
1	C(n)	<b>Transmit Signalling Bits C for Channel n.</b> Where signalling is enabled, these bits are transmitted in bit position 8 of the 18th DS1 frame within the 24 frame structure for ESF superframes. In D4 mode these bits are unused.
0	D(n)	<b>Transmit Signalling Bits D for Channel n.</b> Where signalling is enabled, these bits are transmitted in bit position 8 of the 24th DS1 frame within the 24 frame structure for ESF superframes. In D4 mode these bits are unused.

**Table 72 - Transmit Channel Associated Signalling (T1) (Pages 5,6)**

Serial per channel transmit signalling control through CSTi is selected when the Per Time Slot Control bit RPSIG bit is low. Table 71 describes the bit allocation within each of the 24 active ST-BUS time slots of CSTi.

Bit	Name	Functional Description
7 - 4	A(n), B(n), C(n), D(n)	<b>Transmit Signalling Bits for Channel n.</b> When control bit MSN = 1 and RPSIG = 1 this nibble is used. For ESF links these 4 bits are transmitted on the associated DS1 channel (see table 8) in frames 6, 12, 18 and 24. For D4 links bits A are transmit on the associated DS1 channel of frame 6 and bits B are transmit on the associated DS1 channel of frame 12. For D4 links bits C and D are unused.
3 - 0	A(n), B(n), C(n), D(n)	<b>Transmit Signalling Bits for Channel n.</b> When control bit MSN = 0 and RPSIG = 1 this nibble is used. For ESF links these 4 bits are transmitted on the associated DS1 channel (see table 8) in frames 6, 12, 18 and 24. For D4 links bits A are transmit on the associated Ds1 channel of frame 6 and bits B are transmit on the associated DS1 channel of frame 12. For D4 links bits C and D are unused.

**Table 73 - T1 / Transmit Channels Usage - CSTi**

NOTE: This table illustrates bit mapping on the serial input stream - it does not refer to an internal register.

**Per Time Slot Control Words)(Pages 7 and 8) (T1)**

The control functions described by Table 75 are repeated for each DS1 time slot. Page 7 addresses 10000 to 11111 correspond to DS1 time slot 1 to 16, while page 8 addresses 10000 to 10111 correspond to time slots 17 to 24. Table 74 illustrates the mapping between the addresses of these pages and the DS1 channel numbers.

Page 7 Address:	0	1	2	3	4	5	6	7	8	9	10	11	12	13	14	15
Equivalent DS1 channel	1	2	3	4	5	6	7	8	9	10	11	12	13	14	15	16
Page 8 Address:	0	1	2	3	4	5	6	7	8	9	10	11	12	13	14	15
Equivalent DS1 channel	17	18	19	20	21	22	23	24	x	x	x	x	x	x	x	x

**Table 74 - Pages 7 and 8 Address Mapping to DS1 Channels**

Bit	Name	Functional Description
7	TXMSG	<b>Transmit Message Mode.</b> If high, the data contained in the Transmit Message Register (address 18H, page 1) is transmitted in the corresponding DS1 time slot. If zero, the data on DSTi is transmitted on the corresponding DS1 time slot.
6	PCI	<b>Per Channel Inversion.</b> When set high the data for this channel sourced from DSTi is inverted before being transmit onto the equivalent DS1 channel; the data received from the incoming DS1 channel is inverted before it emerges from DSTo.
5	RTSL	<b>Remote Time Slot Loopback.</b> If one, the corresponding DS1 receive time slot is looped to the corresponding DS1 transmit time slot. This received time slot will also be present on DSTo. If zero, the loopback is disabled.
4	LTSL	<b>Local Time Slot Loopback.</b> If one, the corresponding transmit time slot is looped to the corresponding receive time slot. This transmit time slot will also be present on the transmit DS1 stream. If zero, this loopback is disabled.
3	TTST	<b>Transmit Test.</b> If one, a test signal, either digital milliwatt (when control bit ADSEQ is one) or PRBS ( $Z^{15}-1$ ) (ADSEQ is zero), will be transmitted in the corresponding DS1 time slot. More than one time slot may be activated at once. If zero, the test signal will not be connected to the corresponding time slot.
2	RTST	<b>Receive Test.</b> If one, the corresponding DSTo time slot will be used for testing. If control bit ADSEQ is one, a digital milliwatt signal will be transmitted into the DSTo channel. If ADSEQ is zero, the receive channel will be connected to the PRBS ( $2^{15} - 1$ ) detector.

**Table 75 - Per Time Slot Control Words  
(Pages 7 and 8) (T1)**

Bit	Name	Functional Description
1	RPSIG	<b>Serial Signaling Enable.</b> If set low, the transmit signaling buffer for the equivalent DS1 channel will be sourced from the ST-BUS channel on CSTi associated with it. If set high the transmit signaling RAM must be programmed via the microport.
0	CC	<b>Clear Channel.</b> When set high no robbed bit signaling is inserted in the equivalent transmit DS1 channel. When set low robbed bit signaling is included in every 6th channel.

**Table 75 - Per Time Slot Control Words  
(Pages 7 and 8) (T1)**

**Per Channel Receive Signalling (T1 and E1 mode) (Pages 9 and 0AH)**

Page 09H, addresses 10000 to 11111, and page 1AH addresses 10000 to 10111 contain the Receive Signalling Control Words for DS1 channels 1 to 16 and 17 to 24 respectively. Table 76 illustrates the mapping between the addresses of these pages and the DS1 channel numbers. Table 77 describes bit allocation within each of these registers.

Page 9 Address:	0	1	2	3	4	5	6	7	8	9	10	11	12	13	14	15
Equivalent DS1 channel	1	2	3	4	5	6	7	8	9	10	11	12	13	14	15	16
Page A Address:	0	1	2	3	4	5	6	7	8	9	10	11	12	13	14	15
Equivalent DS1 channel	17	18	19	20	21	22	23	24	x	x	x	x	x	x	x	x

**Table 76 - Page 9, A Address Mapping to DS1 Channels (T1)**

Bit	Name	Functional Description
7 - 4	---	<b>Unused</b>
3	A(n)	<b>Receive Signalling Bits A for Channel n.</b> These bits are extracted from bit position 8 of every channel in received frame 6 (within the 12 frame superframe structure for D4 superframes and the 24 frame structure for ESF superframes). The bits may be debounced for 6 to 9 milliseconds where control bit DBNCE is set high.
3	B(n)	<b>Receive Signalling Bits B for Channel n.</b> These bits are extracted from bit position 8 of every channel in received frame 12 (within the 12 frame superframe structure for D4 superframes and the 24 frame structure for ESF superframes). The bits may be debounced for 6 to 9 milliseconds where control bit DBNCE is set high.
2	C(n)	<b>Receive Signalling Bits C for Channel n.</b> These bits are extracted from bit position 8 of every channel in received frame 18 within the 24 frame structure for ESF superframes. The bits reported may be debounced for 6 to 9 milliseconds where control bit DBNCE is set high. In D4 mode these bits are unused.
0	D(n)	<b>Receive Signalling Bits D for Channel n.</b> These bits are extracted from bit position 8 of every channel in received frame 24 within the 24 frame structure for ESF superframes. The bits reported may be debounced for 6 to 9 milliseconds where control bit DBNCE is set high. In D4 mode these bits are unused.

**Table 77 - Receive Channel Associated Signalling (Pages 9 and A) (T1)**



## E1 Mode

## Master Control 1 (Page 01H) (E1)

Address (A <sub>4</sub> A <sub>3</sub> A <sub>2</sub> A <sub>1</sub> A <sub>0</sub> )	Register	Function
10H (Table 79)	Mode Selection Control Word	ASEL, CRCM, $\overline{\text{AUTC}}$ , $\overline{\text{ARAI}}$ , $\overline{\text{AUTY}}$ , CSYN, REFRM, MFRF
11H (Table 80)	Transmit Alarm Control Word	TE, TAIS16, $\overline{\text{TxAO}}$
12H (Table 81)	HDLC Selection Word	HDLC0, HDLC1, RxTRSP, TxTRSP, TIU1, TIU0
13H (Table 82)	Transmit Multiframe Alignment Signal	TMA1-4, X1, Y, X2, X3
14H (Table 83)	Interrupt and Signalling Control Word	DstoEn, CSToEn, TxCCS, DBNCE, MSN
15H (Table 84)	Coding and Loopback Control Word	RxHDB3, MLBK, HDB3, DLBK, RLBK, SLBK, PLBK
16H (Table 85)	Non Frame Alignment Control Word	RxNFA, TALM, TNU4-8
17H (Table 86)	Multiframe and Data Link Selection	MFSEL, Sa4-Sa8
18H (Table 87)	Transmit Message Word	TXM7-0
19H (Table 88)	Error Insertion Word	BPVE, CRCE, FASE, NFSE, LOSE, PERR, LOS/LOF
1AH (Table 89)	Signalling Control Word	RST, SPND, INTA, CNTCLR, SAMPLE, EXTOSC, GCI/ST
1BH (Table 90)	Interrupt Mask Word Zero	SYNIM, MFSYIM, CSYNIM, AISIM, LOSIM, CEFIM, YIM, SLPIM
1CH (Table 91)	Interrupt Mask Word One	FERIM, CRCIM, EBIM, AIS16IM, BPVIM, PRBSIM, AUXPIM & RAI
1DH (Table 92)	Interrupt Mask Word Two	FEOM, CRCOM, EOM, BPVOM, PRBSOM, PRBSMFO
1EH (Table 93)	Interrupt Mask Word Three	JAIM, 1SECIM, 5SECIM, RCRIM, SIGIM
1FH (Table 94)	LIU Control Word	NRZUNI, REDBL, REMID, REMAX

Table 78 - Master Control 1 (Page 1) (E1)

Bit	Name	Functional Description
7	ASEL	<b>AIS Select.</b> This bit selects the criteria on which the detection of a valid Alarm Indication Signal (AIS) is based. If zero, the criteria is less than three zeros in a two frame period (512 bits). If one, the criteria is less than three zeros in each of two consecutive double-frame periods (512 bits per double frame).
6	CRCM	<b>CRC-4 Modification.</b> If one activates the CRC-4 remainder modification function when the device is in transparent mode. The received CRC-4 remainder is modified to reflect only the changes in the transmit DL. If zero, time slot zero data from DSTi will not be modified in transparent mode.
5	AUTC	<b>Automatic CRC-interworking.</b> If zero, automatic CRC-interworking is activated. If one it is deactivated. See Framing Algorithm for a detailed description.
4	ARAI	<b>Automatic Remote Alarm Indication.</b> if zero, the Remote Alarm Indication bit (the A bit) will function automatically. That is, RAI=1 when basic synchronization has been acquired. And, RAI=0 when basic synchronization has not been acquired. if one, the remote alarm indication bit is controlled through the TALM bit of the transmit Non-Frame Alignment Control Word.
3	AUTY	<b>Automatic Y-Bit Operation.</b> If zero, the Y-bit of the transmit multiframe alignment signal will report the multiframe alignment status to the far end i.e., zero - multiframe alignment acquired, one - lost. If one, the Y-bit is under the manual control of the Transmit Multiframe Alignment Control Word.

Table 79 - Mode Selection Control Word (E1) (Page 1, Address 10H)

Bit	Name	Functional Description
2	CSYN	<b>CRC-4 Synchronization.</b> If zero, basic CRC-4 synchronization processing is activated, and the TIU0 Bit and the TIU1 bit programming will be overwritten. If one, CRC-4 synchronization is disabled. If AUTC (Page 1, Address 10H, bit 5) is also one then the first bits of channel 0 are used as international use bits and are programmed by the TIU0 and TIU1.
1	REFRM	<b>Reframe.</b> If one for at least one frame, and then cleared, the device will initiate a search for a new basic frame position. Reframing function is activated on the one to zero transition of the REFRM bit.
0	MFRF	<b>Multiframe Reframe.</b> If one, for at least one frame, and then cleared the MT9074 will initiate a search for a new signalling multiframe position. Reframing function is activated on the one to zero transition of the MFRM bit.

Table 79 - Mode Selection Control Word (E1) (Page 1, Address 10H)

Bit	Name	Functional Description
7	---	Unused
6	TE	<b>Transmit E bits.</b> When zero and CRC-4 synchronization is achieved, the E-bits transmit the received CRC-4 comparison results to the distant end of the link, as per G.703. That is, when zero and CRC-4 synchronization is lost, the transmit E-bits will be zero. If one, and CRC-4 synchronization is lost the transmit E-bits will be one.
5	TAIS16	<b>Transmit AIS Time Slot 16.</b> If one, an all ones signal is transmitted in time slot 16. If zero, time slot functions normally.
4	TxAO	<b>Transmit All Ones.</b> When low, this control bit forces an unframed all ones to be transmit at TTIP and TRING.

Table 80 - Transmit Alarm Control Word (E1) (Page 1, Address 11H)

Bit	Name	Functional Description
3-0	---	Unused

**Table 80 - Transmit Alarm Control Word (E1)**  
(Page 1, Address 11H)

Bit	Name	Functional Description
7	---	Unused.
6	---	Unused.
5	HDLC0	<b>HDLC0 Select.</b> If one, then HDLC0 is connected to the data link on selected Sa bits at a rate of 4, 8, 12, 16 or 20 kbits/sec. If zero, HDLC0 is deselected and all HDLC0 interrupts are masked.
4	HDLC1	<b>HDLC1 Select.</b> If one, then HDLC1 is connected to time slot 16 in CCS mode. If zero, HDLC1 is deselected and all HDLC1 interrupts are masked.
3	RxTRSP	<b>Receive Transparent Mode.</b> When this bit is set to one, the framing function is disabled on the receive side. Data coming from the receive line passes through the slip buffer and drives DSTo with an arbitrary alignment. When zero, the receive framing function operates normally.
2	TxTRSP	<b>Transmit Transparent Mode.</b> If one, the MT9074 is in transmit transparent mode. No framing or signaling is imposed on the data transmit from DSTi onto the line. If zero, it is in termination mode.
1	TIU1	<b>Transmit International Use One.</b> When CRC-4 operation is disabled ( $\overline{\text{CSYN}}=1$ ), this bit is transmit on the PCM 30 2048 kbit/sec. link in bit position one of time-slot zero of non-frame-alignment frames. It is reserved for international use and should normally be kept at one. If CRC processing is used, i.e., $\overline{\text{CSYN}}=0$ , this bit is ignored.

**Table 81 - HDLC Selection Word (E1)**  
(Page 1, Address 12H)

Bit	Name	Functional Description
0	TIU0	<b>Transmit International Use Zero.</b> When CRC-4 operation is disabled ( $\overline{\text{CSYN}}=1$ ), this bit is transmit on the PCM 30 2048 kbit/sec. link in bit position one of time-slot zero of frame-alignment frames. It is reserved for international use and should normally be kept at one. If CRC processing is used, i.e., $\overline{\text{CSYN}}=0$ , this bit is ignored.

**Table 81 - HDLC Selection Word (E1)**  
(Page 1, Address 12H)

Bit	Name	Functional Description
7-4	TMA1-4	<b>Transmit Multiframe Alignment Bits One to Four.</b> These bits are transmitted on the PCM 30 2048 kbit/sec. link in bit positions one to four of time slot 16 of frame zero of every signalling multiframe. These bits are used by the far end to identify specific frames of a signalling multiframe. TMA1-4 = 0000 for normal operation.
3	X1	This bit is transmitted on the PCM 30 2048 kbit/sec. link in bit position five of time slot 16 of frame zero of every multiframe. X1 is normally set to one.
2	Y	This bit is transmitted on the PCM 30 2048 kbit/sec. link in bit position six of time slot 16 of frame zero of every multiframe. It is used to indicate the loss of multiframe alignment to the remote end of the link. If one - loss of multiframe alignment; if zero - multiframe alignment acquired. This bit is ignored when AUTY is zero (page 01H, address 10H).

**Table 82 - Transmit Multiframe Alignment Signal (E1)**  
(Page 1, Address 13H)

Bit	Name	Functional Description
1-0	X2, X3	These bits are transmitted on the PCM 30 2048 kbit/sec. link in bit positions seven and eight respectively, of time slot 16 of frame zero of every multiframe. X2 and X3 are normally set to one. If receive channel 16 data is to be included in the looped data then the control bit TxCCS (Page, Address 14H, bit 5) must be set high, otherwise transmit signaling data, or HOLCC data will be placed into the outgoing channel 16 timeslot.

**Table 82 - Transmit Multiframe Alignment Signal (E1)**  
(Page 1, Address 13H)

Bit	Name	Functional Description
7	DSToEn	<b>DSTo Enable.</b> If zero pin DSTo is tristate. If set, the pin DSTo is enabled.
6	CSToEn	<b>CSTo Enable.</b> If zero pin CSTo is tristate. If set, the pin CSTo is enabled.
5	TxCCS	<b>Transmit Common Channel Signalling.</b> If one, the transmit section of the device is in common channel signalling (CCS) mode. If zero, it is in Channel Associated Signalling (CAS) mode.
4	DBNCE,	<b>Debounce Select.</b> This bit selects the debounce period (1 for 14 msec.; 0 for no debounce). Note: there may be as much as 2 msec. added to this duration because the state change of the signalling equipment is not synchronous with the PCM 30 signalling multiframe.

**Table 83 - Interrupt and Signalling Control Word (E1)**  
(Page 1, Address 14H)

Bit	Name	Functional Description
3	MSN	<b>Most Significant Signalling Nibble.</b> If one, the CSTo and CSTi channel associated signalling nibbles will be valid in the most significant portion of each ST-BUS time slot. If zero, the CSTo and CSTi channel associated signalling nibbles will be valid in the least significant portion of each ST-BUS time slot.
2-0	---	<b>Unused.</b>

**Table 83 - Interrupt and Signalling Control Word (E1)**  
(Page 1, Address 14H)

Bit	Name	Functional Description
7	RxHDB3	<b>High Density Bipolar 3 Encoding.</b> If one, HDB3 encoding is enabled in the receive direction. If zero, AMI signal without HDB3 encoding is received
6	MLBK	<b>Metallic Loopback.</b> If one, then the external RRTIP and RRING signals are isolated from the receiver, and TTIP and TRING are internally connected to the receiver analog input instead. If zero, metallic loopback is disabled.
5	TxHDB3	<b>High Density Bipolar 3 Encoding.</b> If one, HDB3 encoding is enabled in the transmit direction. If zero, AMI signal without HDB3 encoding is transmitted.
4	---	<b>Unused.</b>
3	DLBK	<b>Digital Loopback.</b> If one, then the digital stream to the transmit LIU is looped back in place of the digital output of the receive LIU. Data coming out of DSTo will be a delayed version of DSTi. If zero, this feature is disabled.

**Table 84 - Coding and Loopback Control Word (E1)**  
(Page 1, Address 15H)

Bit	Name	Functional Description
2	RLBK	<b>Remote Loopback.</b> If one, then all bipolar data received on RRTIP/RRING are directly routed to TTIP/TRING on the PCM 30 side of the MT9074. If zero, then this feature is disabled.
1	SLBK	<b>ST-BUS Loopback.</b> If one, then all time slots of DSTi are connected to DSTo on the ST-BUS side of the MT9074. If zero, then this feature is disabled. See Loopbacks section.
0	PLBK	<b>Payload Loopback.</b> If one, then all time slots received on RTIP/RRING are connected to TTIP/TRING on the ST-BUS side of the MT9074 (this excludes time slot zero). If zero, then this feature is disabled. If receive channel 16 data is to be included in the looped data, then the control bit TxCCS (Page 1, Address 14H, bit 5) must be set high, otherwise transmit signalling data, or HDLC1 data will be placed into the outgoing channel 16 timeslot.

**Table 84 - Coding and Loopback Control Word (E1)**  
(Page 1, Address 15H)

Bit	Name	Functional Description
7	---	<b>Unused.</b>
6	RxNFA	<b>Receive Non-frame Alignment Byte.</b> This bit decides the contents of channel 0 of DSTo. When RxNFA=1, channel 0 of DSTo contains only data from the received non frame alignment signal (NFAS). When RxNFA = 0, channel 0 of DSTo contains both frame alignment and non frame alignment bytes received with the rest of the frame.

**Table 85 - Non Frame Alignment Control Word (E1)**  
(Page 1, Address 16H)

Bit	Name	Functional Description
5	TALM	<b>Transmit Remote Alarm.</b> This bit is transmitted on the PCM 30 2048 kbit/sec. link in bit position three (A bit) of time slot zero of NFAS frames. It is used to signal an alarm to the remote end of the PCM 30 link (one - alarm, zero - normal). This control bit is ignored when ARAI is zero (page 01H, address 10H).
4-0	TNU4-8	<b>Transmit National Use Four to Eight (Sa4 - Sa8).</b> These bits are transmitted on the PCM 30 2048 kbit/sec. link in bit positions four to eight of time slot zero of the NFA frame, if selected by Sa4 - Sa8 control bits of the DL selection word (page 01H, address 17H).

**Table 85 - Non Frame Alignment Control Word (E1)**  
(Page 1, Address 16H)

Bit	Name	Functional Description
7	---	<b>Unused</b>
6	MFSEL	<b>Multiframe Select.</b> This bit determines which receive multiframe signal (CRC-4 or signalling) the RxMF (pin 42 in PLCC, 23 in MQFP) signal is aligned with. If zero, RxMF is aligned with the receive signalling multiframe. If one, RxMF is aligned with the receive CRC-4 multiframe.
5	----	<b>Unused</b>

**Table 86 - Multiframe and Data Link Selection (E1)**  
(Page 1, Address 17H)

Bit	Name	Functional Description
4-0	Sa4-Sa8	A one selects the corresponding Sa bits of the NFA signal for 4, 8, 12, 16 or 20 kbits/sec. data link channel. Data link (DL) selection will function in termination mode only; in transmit transparent mode Sa4 is automatically selected - see TxTRSP control bit of page 01H, address 11H. If zero, the corresponding bits of transmit non-frame alignment signal are programmed by the Non-Frame Alignment Control Word (page 01H, address 16H).

**Table 86 - Multiframe and Data Link Selection (E1)**  
(Page 1, Address 17H)

Bit	Name	Functional Description
7-0	TxM7-0	<b>Transmit Message Bits 7 - 0.</b> The contents of this register are transmit into those outgoing DS1 channels selected by the Per Time Slot Control registers.

**Table 87 - Transmit Message Word (E1)**  
(Page 1, Address 18H)

Bit	Name	Functional Description
7	BPVE	<b>Bipolar Violation Error Insertion.</b> A zero to one transition of this bit inserts a single bipolar violation error into the transmit PCM 30 data. A one, zero or one to zero transition has no function.
6	CRCE	<b>CRC-4 Error Insertion.</b> A zero to one transition of this bit inserts a single CRC-4 error into the transmit PCM 30 data. A one, zero, or one to zero transition has no function.
5	FASE	<b>Frame Alignment Signal Error Insertion.</b> A zero to one transition of this bit inserts a single error into the time slot zero frame alignment signal of the transmit PCM 30 data. A one, zero, or one to zero transition has no function.

**Table 88 - Error Insertion Word (E1)**  
(Page 1, Address 19H)

Bit	Name	Functional Description
4	NFSE	<b>Non-frame Alignment Signal Error Insertion.</b> A zero to one transition of this bit inserts a single error into bit two of the time slot zero non-frame alignment signal of the transmit PCM 30 data. A one, zero, or one to zero transition has no function.
3	LOSE	<b>Loss of Signal Error Insertion.</b> If one, the MT9074 transmits an all zeros signal (no pulses) in every PCM 30 time slot. When HDB3 encoding is activated no violations are transmitted. If zero, data is transmitted normally.
2	PERR	<b>Payload Error Insertion.</b> A zero to one transition of this bit inserts a single error in the transmit payload. A one, zero, or one to zero transition has no function.
1	---	<b>Unused</b>
0	LOS/LOF	<b>Loss of Signal or Loss of Frame Selection.</b> If one, pin LOS (pin 61 in PLCC, 57 in MQFP) will go high when a loss of signal state exits. A loss of signal is defined as either receipt of a signal attenuated below the analog loss of signal threshold (selectable as 20 dB or 40 dB below nominal) or receipt of 192 consecutive 0's. If low, pin LOS will go high when either a loss of signal or a loss of basic frame alignment state exits (bit SYNC on page 03H address 10H is zero).

**Table 88 - Error Insertion Word (E1)**  
(Page 1, Address 19H)



Bit	Name	Functional Description
7	RST	<b>Reset.</b> When this bit is changed from zero to one the device will reset to its default mode. See the Reset Operation section for the default settings.
6	SPND	<b>Suspend Interrupts.</b> If one, the IRQ output (pin 12 in PLCC, 85 in MQFP) will be in a high-impedance state and all interrupts will be ignored. If zero, the IRQ output will function normally.
5	INTA	<b>Interrupt Acknowledge.</b> A zero-to-one or one-to-zero transition will clear any pending interrupt and make IRQ high impedance.
4	CNTCLR	<b>Counter Clear.</b> If one, all status counters are cleared and held low. Zero for normal operation.
3	SAMPLE	<b>One Second Sample.</b> Setting this bit causes the error counters (change of frame alignment, loss of frame alignment, bpv errors, crc errors, severely errored frame events and multiframes out of sync) to be updated on one second intervals coincident with the one second timer (status page 3 address 12H bit 7).
2	EXTOSC	<b>External Oscillator Select.</b> Setting this bit connects the pin OSC1 to a TTL compatible input. This allows for a system design employing a TTL output oscillator as a 20.000 Mhz reference clock.
1	RSV	<b>Reserved.</b> Must be kept at 0 for normal operation.
0	---	<b>Unused.</b>

**Table 89 - Signalling Control Word (E1)**  
(Page 1, Address 1AH)

Bit	Name	Functional Description
7	SYNIM	<b>Synchronization Interrupt Mask.</b> When unmasked (SYNI=1) an interrupt is initiated whenever change of state of basic frame synchronization condition exists. If 1 - unmasked, 0 - masked.
6	MFSYIM	<b>Multiframe Synchronization Interrupt Mask.</b> When unmasked (MFSYI=1), an interrupt is initiated whenever a change of state of multiframe synchronization is lost. If 1 - unmasked, 0 - masked.
5	CSYNIM	<b>CRC-4 Multiframe Synchronization Interrupt Mask.</b> When unmasked (CSYNI=1), an interrupt is initiated whenever a change of state of CRC-4 multiframe synchronization exists. If 1 - unmasked, 0 - masked.
4	AISIM	<b>Alarm Indication Signal Interrupt Mask.</b> When unmasked (AISI=1) a change of state of received AIS will initiate an interrupt. If 1 - unmasked, 0 - masked.
3	LOSIM	<b>Loss of Signal Interrupt Mask.</b> When unmasked this interrupt bit goes high whenever a change of state of loss of signal (either analog - received signal 20 or 40 dB below nominal or digital - 192 consecutive 0's received) condition exists. If 1 - unmasked, 0 - masked.
2	CEFIM	<b>Consecutively Errored FASs Interrupt Mask.</b> When unmasked an interrupt is initiated when two consecutive errored frame alignment signals are received. If 1 - unmasked, 0 - masked.

**Table 90 - Interrupt Mask Word Zero (E1)**  
(Page 1, Address 1BH)

Bit	Name	Functional Description
1	YIM	<b>Remote Signalling Multiframe Alarm Interrupt Mask.</b> When unmasked (YI=1), an interrupt is initiated whenever a change of state of remote signalling multiframe alarm signal is received. If 1 - unmasked, 0 - masked.
0	SLPIM	<b>SLIP Interrupt Mask.</b> When unmasked (SLPI=1), an interrupt is initiated when a controlled frame slip occurs. If 1 - unmasked, 0 - masked.

**Table 90 - Interrupt Mask Word Zero (E1)  
(Page 1, Address 1BH)**

Bit	Name	Functional Description
2	PRBSIM	<b>PRBS Interrupt Mask.</b> When unmasked (PRBSI = 1), an interrupt is initiated on a single PRBS detection error. If 1 - unmasked, 0 - masked.
1	AUXPIM	<b>Auxiliary Pattern Interrupt Mask.</b> When unmasked (AUXPI = 1), an interrupt is initiated when the AUXP status bit of page 03H, address 15H goes high. If 1 - unmasked, 0 - masked.
0	RAIIM	<b>Remote Alarm Indication Interrupt Mask.</b> When unmasked (RAII = 1) a received RAI will initiate an interrupt. If 1 - unmasked, 0 - masked.

**Table 91 - Interrupt Mask Word One (E1)  
(Page 1, Address 1CH)**

Bit	Name	Functional Description
7	FERIM	<b>Frame Error Interrupt Mask.</b> When unmasked (FERI = 1), an interrupt is initiated when an error in the frame alignment signal occurs. If 1 - unmasked, 0 - masked.
6	CRCIM	<b>CRC-4 Error Interrupt Mask.</b> When unmasked an interrupt is initiated when a local CRC-4 error occurs. 1 - unmasked, 0 - masked. If 1 - unmasked, 0 - masked.
5	EBIM	<b>Receive E-bit Interrupt Mask.</b> When unmasked an interrupt is initiated when a receive E-bit indicates a remote CRC-4 error. 1 - unmasked, 0 - masked. If 1 - unmasked, 0 - masked.
4	AIS16IM	<b>Channel 16 Alarm Indication Signal Interrupt Mask.</b> When unmasked (AIS16I = 1), a received AIS16 will initiate an interrupt. If 1 - unmasked, 0 - masked.
3	BPVIM	<b>Bipolar Violation Interrupt Mask.</b> When unmasked an interrupt is initiated when a bipolar violation error occurs. 1 - unmasked, 0 - masked.

**Table 91 - Interrupt Mask Word One (E1)  
(Page 1, Address 1CH)**

Bit	Name	Functional Description
7	FEOM	<b>Frame Alignment Signal Error Counter Overflow Interrupt Mask.</b> When unmasked an interrupt is initiated when the frame alignment signal error counter overflows. If 1 - unmasked, 0 - masked.
6	CRCOIM	<b>CRC-4 Error Counter Overflow Interrupt.</b> When unmasked an interrupt is initiated when the CRC-4 error counter overflows. If 1 - unmasked, 0 - masked.
5	EBOIM	<b>Receive E-bit Counter Overflow Interrupt.</b> When unmasked an interrupt is initiated when the E-bit error counter overflows. If 1 - unmasked, 0 - masked.
4	---	<b>Unused.</b>
3	BPVCOM	<b>Bipolar Violation Counter Overflow Interrupt.</b> When unmasked (BPVO = 1), an interrupt is initiated when the bipolar violation error counter changes form FFFFH to 0H. If 1 - unmasked, 0 - masked.

**Table 92 - Interrupt Mask Word Two (E1)  
(Page 1, Address 1DH)**

Bit	Name	Functional Description
2	PRBSOM	<b>PRBS Counter Overflow Interrupt.</b> When unmasked (PRBSO = 1), an interrupt is initiated on overflow of PRBS counter (page 04H, address 10H) from FFH to 0H. If 1 - unmasked, 0 - masked.
1	PRBSMFO M	<b>PRBS MultiFrame Counter Overflow Interrupt</b> When unmasked an interrupt will be generated whenever the multiframe counter attached to the PRBS error counter overflows. If 1 - unmasked, 0 - masked.
0	---	<b>Unused.</b>

**Table 92 - Interrupt Mask Word Two (E1)  
(Page 1, Address 1DH)**

Bit	Name	Functional Description
0	SIGIM	<b>Signalling (CAS) Interrupt Mask.</b> When unmasked and any of the receive ABCD bits of any channel changes state an interrupt is initiated. If 1 - unmasked, 0 - masked.

**Table 93 - Interrupt Mask Word Three (E1)  
(Page 1, Address 1EH)**

Bit	Name	Functional Description
7-5	---	<b>Unused</b>
4	JAIM	<b>Jitter Attenuation Interrupt Mask.</b> When unmasked, an interrupt will be initiated when the jitter attenuator FIFO comes within four bytes of an overflow or underflow condition. If 1 - unmasked, 0 - masked.
3	1SECIM	<b>One Second Status Interrupt Mask.</b> When unmasked (1SECI = 1), an interrupt is initiated when the 1SEC status bit changes from zero to one. If 1 - unmasked, 0 - masked.
2	5SECIM	<b>Five Second Status Interrupt Mask.</b> When unmasked (5SECI = 1), an interrupt is initiated when the 5SECI status bit changes from zero to one. If 1 - unmasked, 0 - masked.
1	RCRIM	<b>RCRI Interrupt Mask.</b> When unmasked (RCRI=1), an interrupt is initiated when RCR (remote alarm & CRC-4 error) status bit changes from zero to one. If 1 - unmasked, 0 - masked.

**Table 93 - Interrupt Mask Word Three (E1)  
(Page 1, Address 1EH)**

Bit	Name	Functional Description																																																						
7	NRZ	<b>NRZ Format Selection.</b> Only used in the digital framer only mode (LIU is disabled). A one sets the MT9074 to accept a unipolar NRZ format input stream on RxA as the line input, and to transmit a unipolar NRZ format stream on TxB. A zero causes the MT9074 to accept a complementary pair of dual rail inputs on RxA/RxB and to transmit a complementary pair of dual rail outputs on TxA/TxB.																																																						
6-4	TX2-0	<p><b>Transmit pulse amplitude.</b> Select the TX2 –TX0 bits according to the line type, value of termination resistors (RT), and transformer turns ratio used</p> <table border="1"> <thead> <tr> <th>TX2</th> <th>TX1</th> <th>TX0</th> <th>Line Impedance(ohms)</th> <th>RT(ohms)</th> <th>Transformer Ratio</th> </tr> </thead> <tbody> <tr> <td>0</td> <td>0</td> <td>0</td> <td>120</td> <td>0</td> <td>1:2</td> </tr> <tr> <td>0</td> <td>0</td> <td>1</td> <td>120</td> <td>0</td> <td>1:1</td> </tr> <tr> <td>0</td> <td>1</td> <td>0</td> <td>120</td> <td>15</td> <td>1:2</td> </tr> <tr> <td>0</td> <td>1</td> <td>1</td> <td>120/75</td> <td>12.1</td> <td>1:2</td> </tr> <tr> <td>1</td> <td>0</td> <td>0</td> <td>75</td> <td>0</td> <td>1:2</td> </tr> <tr> <td>1</td> <td>0</td> <td>1</td> <td>75</td> <td>0</td> <td>1:1</td> </tr> <tr> <td>1</td> <td>1</td> <td>1</td> <td>75</td> <td>9.1</td> <td>1:2</td> </tr> <tr> <td>1</td> <td>1</td> <td>1</td> <td>75/120</td> <td>12.1</td> <td>1:2</td> </tr> </tbody> </table> <p>After reset these bits are zero.</p>	TX2	TX1	TX0	Line Impedance(ohms)	RT(ohms)	Transformer Ratio	0	0	0	120	0	1:2	0	0	1	120	0	1:1	0	1	0	120	15	1:2	0	1	1	120/75	12.1	1:2	1	0	0	75	0	1:2	1	0	1	75	0	1:1	1	1	1	75	9.1	1:2	1	1	1	75/120	12.1	1:2
TX2	TX1	TX0	Line Impedance(ohms)	RT(ohms)	Transformer Ratio																																																			
0	0	0	120	0	1:2																																																			
0	0	1	120	0	1:1																																																			
0	1	0	120	15	1:2																																																			
0	1	1	120/75	12.1	1:2																																																			
1	0	0	75	0	1:2																																																			
1	0	1	75	0	1:1																																																			
1	1	1	75	9.1	1:2																																																			
1	1	1	75/120	12.1	1:2																																																			
3	REDBL	<b>Receive Equalizer Disable.</b> If one the receive equalizer is turned off. If zero, the receive equalizer is turned on and will compensate for loop length automatically.																																																						
2-0	RES2-0	<p><b>Receive Equalization Select.</b> Setting these pins forces a level of equalization of the incoming line data.</p> <table border="1"> <thead> <tr> <th>RES2</th> <th>RES1</th> <th>RES0</th> <th>Receive Equalization</th> </tr> </thead> <tbody> <tr> <td>0</td> <td>0</td> <td>0</td> <td>none</td> </tr> <tr> <td>0</td> <td>0</td> <td>1</td> <td>6dB</td> </tr> <tr> <td>0</td> <td>1</td> <td>0</td> <td>12dB</td> </tr> <tr> <td>0</td> <td>1</td> <td>1</td> <td>18dB</td> </tr> <tr> <td>1</td> <td>0</td> <td>0</td> <td>24dB</td> </tr> <tr> <td>1</td> <td>0</td> <td>1</td> <td>reserved</td> </tr> <tr> <td>1</td> <td>1</td> <td>0</td> <td>reserved</td> </tr> <tr> <td>1</td> <td>1</td> <td>1</td> <td>reserved</td> </tr> </tbody> </table> <p>These settings have no effect if REDBL is set to zero.</p>	RES2	RES1	RES0	Receive Equalization	0	0	0	none	0	0	1	6dB	0	1	0	12dB	0	1	1	18dB	1	0	0	24dB	1	0	1	reserved	1	1	0	reserved	1	1	1	reserved																		
RES2	RES1	RES0	Receive Equalization																																																					
0	0	0	none																																																					
0	0	1	6dB																																																					
0	1	0	12dB																																																					
0	1	1	18dB																																																					
1	0	0	24dB																																																					
1	0	1	reserved																																																					
1	1	0	reserved																																																					
1	1	1	reserved																																																					

Table 94 - LIU Control Word (E1)  
(Page 1, Address 1FH)

## Master Control 2 (Page-2)

## Master Control 2 (Page 02H) (E1)

Address (A <sub>4</sub> A <sub>3</sub> A <sub>2</sub> A <sub>1</sub> A <sub>0</sub> )	Register	Names
10H (Table 96)	Configuration Control Word	T1/E1, LIUE $\bar{n}$ , ELOS, ADSEQ
11H (Table 97)	Custom Tx Pulse Enable	CPL
12H	Reserved	Set all bits to zero for normal operation.
13H	Reserved	Set all bits to zero for normal operation.
14H	Reserved	Set all bits to zero for normal operation.
15H	Reserved	Set all bits to zero for normal operation.
16H	Reserved	Set all bits to zero for normal operation.
17H	Reserved	Set all bits to zero for normal operation.
18H	Reserved	Set all bits to zero for normal operation.
19H	Reserved	Set all bits to zero for normal operation.
1AH	Reserved	Set all bits to zero for normal operation.
1BH	Reserved	Set all bits to zero for normal operation.
1CH (Table 98)	Custom Pulse Word 1	CP6-0
1DH (Table 99)	Custom Pulse Word 2	CP6-0
1EH (Table 100)	Custom Pulse Word 3	CP6-0
1FH (Table 101)	Custom Pulse Word 4	CP6-0

Table 95 -Master Control 2 (Page 02H) (E1)

Bit	Name	Functional Description
7	T1/E1	<b>E1 mode selection.</b> when this bit is one, the device is in E1 mode.
6-5	RSV	<b>Reserved.</b> Must be kept at 0 for normal operation.
4	LIUEn	<b>LIU Enable.</b> Setting this bit low enables the internal LIU front-end. Setting this pin high disables the LIU. Digital inputs RXA and RXB are sampled by the rising edge of E2.0i (C1.50) to strobe in the received line data. Digital transmit data is clocked out of pins TXA and TXB with the rising edge of C2.0o
3	ELOS	<b>ELOS Enable.</b> Set this bit low to set the analog loss of signal threshold to 40 dB below nominal. Set this bit high to set the analog loss of signal threshold to 20 dB below nominal.
2	RSV	<b>Reserved.</b> Must be kept at 0 for normal operation.
1	ADSEQ	<b>Digital Milliwatt or Digital Test Sequence.</b> If one, the A-law digital milliwatt analog test sequence will be selected by the Per Time Slot Control bits TTST and RTST.If zero, a PRBS generator / detector will be connected to channels with TTST, RRST respectively
0	RSV	<b>Reserved.</b> Must be kept at 0 for normal operation.

**Table 96 - Configuration Control Word (Page 2, Address 10H) (E1)**

Bit	Name	Functional Description
7	RSV	<b>Reserved.</b> Must be kept high for normal operation.
6-4	RSV	<b>Reserved.</b> Must be kept low for normal operation.
3	CPL	<b>Custom Pulse Level.</b> Setting this bit low enables the internal ROM values in generating the transmit pulses. The ROM is coded for different line terminations or build out, as specified in the LIU Control word. Setting this bit high disables the pre-programmed pulse templates. Each of the 4 phases that generate a mark derive their D/A coefficients from the values programmed in the CPW registers.
2-0	RSV	<b>Reserved.</b> Must be kept at 0 for normal operation.

**Table 97 - Custom Tx Pulse Enable (Page 2, Address 11H) (E1)**

Bit	Name	Functional Description
7	RSV	<b>Reserved.</b> Must be kept at 0 for normal operation.
6-0	CP6-0	<b>Custom Pulse.</b> These bits provide the capability for programming the magnitude setting for the TTIP/TRING line driver A/D converter during the first phase of a mark. The greater the binary number loaded into the register, the greater the amplitude driven out. This feature is enabled when the control bit 3 - CPL of the Custom Tx Pulse Enable Register - address 11H of Page 2 is set high.

**Table 98 - Custom Pulse Word 1 (Page 2, Address 1CH) (E1)**

Bit	Name	Functional Description
7	RSV	<b>Reserved.</b> Must be kept at 0 for normal operation.
6-0	CP6-0	<b>Custom Pulse.</b> These bits provide the capability for programming the magnitude setting for the TTIP/TRING line driver A/D converter during the second phase of a mark. The greater the binary number loaded into the register, the greater the amplitude driven out. This feature is enabled when the control bit 3 - CPL of the Custom Tx Pulse Enable Register - address 11H of Page 2 is set high.

**Table 99 - Custom Pulse Word 2  
(Page 2, Address 1DH) (E1)**

Bit	Name	Functional Description
7	RSV	<b>Reserved.</b> Must be kept at 0 for normal operation.
6-0	CP6-0	<b>Custom Pulse.</b> These bits provide the capability for programming the magnitude setting for the TTIP/TRING line driver A/D converter during the fourth phase of a mark. The greater the binary number loaded into the register, the greater the amplitude driven out. This feature is enabled when the control bit 3 - CPL of the Custom Tx Pulse Enable Register - address 11H of Page 2 is set high.

**Table 101 - Custom Pulse Word 4  
(Page 2, Address 1FH) (E1)**

Bit	Name	Functional Description
7	RSV	<b>Reserved.</b> Must be kept at 0 for normal operation.
6-0	CP6-0	<b>Custom Pulse.</b> These bits provide the capability for programming the magnitude setting for the TTIP/TRING line driver A/D converter during the third phase of a mark. The greater the binary number loaded into the register, the greater the amplitude driven out. This feature is enabled when the control bit 3 - CPL of the Custom Tx Pulse Enable Register - address 11H of Page 2 is set high.

**Table 100 - Custom Pulse Word 3  
(Page 2, Address 1EH) (E1)**



**Master Status 1 (Page03H) (E1)**

<b>Address (A<sub>4</sub>A<sub>3</sub>A<sub>2</sub>A<sub>1</sub>A<sub>0</sub>)</b>	<b>Register</b>	<b>Function</b>
10H (Table 103)	Synchronization Status Word	SYNC, MFSYNC, CRCSYN, REB1, REB2, CRCRF, RED, CRCIWK
11H (Table 104)	Alarm Status Word 1	CRCS1, CRCS2, RFAIL, LOSS, AIS16S, AISS, RAIS, RCRS
12H (Table 105)	Timer Status Word	1SEC, 2SEC, 400T, 8T, CALN, KLVE, T1,T2
13H (Table 106)	Most Significant Phase Status Word	RSLIP, RSLPD, RXFRM, AUXP, CEFS
14H (Table 107)	Least Significant Phase Status Word	RxTS4-0, RxBC2-0
15H (Table 108)	Receive Frame Alignment Signal	RIU0 &RFA2-8
16H (Table 109)	Receive Signal Status Word	EQSTAT4-0, LLOS
17H (Table 110)	Jitter Attenuator Status Word	JACS, JACF, JAE, JAF4, JAF4, JAE4, JAF
18H (Table 111)	Receive Non-frame Alignment Signal	RIU1, RNFA2, RALM, &RNU4-8
19H (Table 112)	Receive Multiframe Alignment Signal	RMAI1-4, X1, Y, X2, & X3
1AH	Unused	
1BH (Table 113)	Alarm Status Word 2	RAIS, AISS, AIS16S, LOSS, AUXPS, MFALMS, SLIPS
1CH-1EH	Unused	
1FH (Table 114)	Identification Register	Set to 10101111

**Table 102 - Master Status 1 (Page 3) (E1)**

Bit	Name	Functional Description
7	$\overline{\text{SYNC}}$	<b>Receive Basic Frame Alignment.</b> SYNC indicates the basic frame alignment status (1 - loss; 0 - acquired).
6	$\overline{\text{MFSYNC}}$	<b>Receive Multiframe Alignment.</b> MFSYNC indicates the multiframe alignment status (1 - loss; 0 - acquired).
5	$\overline{\text{CRCSYN}}$	<b>Receive CRC-4 Synchronization.</b> CRCSYN indicates the CRC-4 multiframe alignment status (1 - loss; 0 - acquired).
4	REB1	<b>Receive E-Bit One Status.</b> REB1 indicates the status of the received E1 bit of the last multiframe.
3	REB2	<b>Receive E-Bit Two Status.</b> REB2 indicates the status of the received E2 bit of the last multiframe.
2	CRCRF	<b>CRC-4 Reframe.</b> A one indicates that the receive CRC-4 multiframe synchronization could not be found within the time out period of 8 msec. after detecting basic frame synchronization. This will force a reframe when the maintenance option is selected and automatic CRC-4 interworking is de-selected.
1	RED	<b>RED Alarm.</b> RED goes high when basic frame alignment has been lost for at least 100 msec. This bit will be low when basic frame alignment is acquired (I.431).
0	CRCIWK	<b>CRC-4 Interworking.</b> CRCIWK indicates the CRC-4 interworking status (1 - CRC-to-CRC; 0 - CRC-to-non-CRC).

**Table 103 - Synchronization Status Word  
(Page 3, Address 10H) (E1)**

Bit	Name	Functional Description
7	CRCS1	<b>Receive CRC Error Status One.</b> If one, the evaluation of the last received submultiframe 1 resulted in an error. If zero, the last submultiframe 1 was error free. Updated on a submultiframe 1 basis.
6	CRCS2	<b>Receive CRC Error Status Two.</b> If one, the evaluation of the last received submultiframe 2 resulted in an error. If zero, the last submultiframe 2 was error free. Updated on a submultiframe 2 basis.
5	RFAIL	<b>Remote CRC-4 Multiframe Generator/Detector Failure.</b> If one, then each of the previous five seconds have an E-bit error count of greater than 989, and for this same period the receive RAI bit was zero (no remote alarm), and for the same period the SYNC bit was equal to zero (basic frame alignment has been maintained). If zero, indicates normal operation.
4	LOSS	<b>Loss of Signal Status.</b> If one, indicates the presence of a loss of signal condition. If zero, indicates normal operation. A loss of signal condition occurs when 192 consecutive bit periods are zero. A loss of signal condition terminates when an average ones density of at least 12.5% has been received over a period of 192 contiguous pulse positions starting with a pulse.
3	AIS16S	<b>Alarm Indication Signal 16 Status.</b> If one, indicates an all ones alarm is being received in channel 16. If zero, normal operation. Updated on a frame basis.
2	AISS	<b>Alarm Indication Status Signal.</b> If one, indicates that a valid AIS or all ones signal is being received. If zero, indicates that a valid AIS signal is not being received. The criteria for AIS detection is determined by the control bit ASEL.

**Table 104 - Alarm Status Word 1  
(Page 3, Address 11H) (continued) (E1)**

Bit	Name	Functional Description
1	RAIS	<b>Remote Alarm Indication Status.</b> If one, there is currently a remote alarm condition (i.e., received A bit is one). If zero, normal operation. Updated on a non-frame alignment frame basis.
0	RCRS	<b>RAI and Continuous CRC Error Status.</b> If one, there is currently an RAI and continuous CRC error condition. If zero, normal operation. Updated on a multiframe basis.

**Table 104 - Alarm Status Word 1 (Page 3, Address 11H) (continued) (E1)**

Bit	Name	Functional Description
7	1SEC	<b>One Second Timer Status.</b> This bit changes state once every 0.5 second and is synchronous with the 2SEC timer.
6	2SEC	<b>Two Second Timer Status.</b> This bit changes state once every second and is synchronous with the 1SEC timer.
5	400T	<b>400 msec. Timer Status.</b> This bit changes state when the 400 msec. CRC-4 multiframe alignment timer expires.
4	--	<b>Unused.</b>
3	CALN	<b>CRC-4 Alignment.</b> This bit changes state every msec. When CRC-4 multiframe alignment has been achieved state changes of this bit are synchronous with the receive CRC-4 synchronization signal.
2	KLVE	<b>Keep Alive.</b> This bit is high when the AIS status bit has been high for at least 100msec. This bit will be low when AIS goes low (I.431).
1	T1	<b>Timer One.</b> This bit will be high upon loss of terminal frame synchronization persisting for 100 msec. This bit shall be low when T2 becomes high. Refer to I.431 Section 5.9.2.2.3.
0	T2	<b>Timer Two.</b> This bit will be high when the MT9074 acquires terminal frame synchronization persisting for 10 msec. This bit shall be low when non-normal operational frames are received. I.431 Section 5.9.2.2.3.

**Table 105 - Timer Status Word (Page 3, Address 12H) (E1)**

Bit	Name	Functional Description
7	RSLIP	<b>Receive Slip.</b> A change of state (i.e., 1-to-0 or 0-to-1) indicates that a receive controlled frame slip has occurred.
6	RSLPD	<b>Receive Slip Direction.</b> If one, indicates that the last received frame slip resulted in a repeated frame, i.e., system clock is faster than network clock. If zero, indicates that the last received frame slip resulted in a lost frame, i.e., system clock is slower than network clock. Updated on an RSLIP occurrence basis.
5	RXFRM	<b>Receive Frame Delay.</b> The most significant bit of the Receive Slip Buffer Phase Status Word. If zero, the delay through the receive elastic buffer is greater than one frame in length; if one, the delay through the receive elastic buffer is less than one frame in length.
4	AUXP	<b>Auxiliary Pattern.</b> This bit will go high when a continuous 101010... bit stream (Auxiliary Pattern) is received on the PCM 30 link for a period of at least 512 bits. If zero, auxiliary pattern is not being received. This pattern will be decoded in the presence of a bit error rate of as much as 10-3.
3	CEFS	<b>Consecutively Errored Frame Alignment Signal.</b> This bit goes high when the last two frame alignment signals were received in error. This bit will be low when at least one of the last two frame alignment signals is without error.
2-0	---	<b>Unused.</b>

Table 106 - Most Significant Phase Status Word (Page 3, Address 13H) (E1)

Bit	Name	Functional Description
7 - 3	RxTS4 - 0	<b>Receive Time Slot.</b> A five bit counter that indicates the number of time slots between the receive elastic buffer internal write frame boundary and the ST-BUS read frame boundary. The count is updated every 250 uS.
2 - 0	RxBC2 - 0	<b>Receive Bit Count.</b> A three bit counter that indicates the number of STBUS bit times there are between the receive elastic buffer internal write frame boundary and the ST-BUS read frame boundary. The count is updated every 250 uS.

Table 107 - Least Significant Phase Status Word (Page 3, Address 14H) (E1)

Bit	Name	Functional Description
7	RIU0	<b>Receive International Use Zero.</b> This is the bit which is received on the PCM 30 2048 kbit/sec. link in bit position one of the frame alignment signal. It is used for the CRC-4 remainder or for international use.
6-0	RFA2-8	<b>Receive Frame Alignment Signal Bits 2 to 8.</b> These bit are received on the PCM 30 2048 kbit/sec. link in bit positions two to eight of frame alignment signal. These bits form the frame alignment signal and should be 0011011.

Table 108 - Receive Frame Alignment Signal (Page 3, Address 15H) (E1)

Bit	Name	Functional Description																																				
7 - 3	PD4 - PD0	<p><b>Peak Detector Voltage Levels.</b> These five bits indicate the level of the received signal AMI pulses.</p> <table border="1"> <thead> <tr> <th>PD4</th> <th>PD3</th> <th>PD2</th> <th>PD1</th> <th>PD0</th> <th>Line Attenuation</th> </tr> </thead> <tbody> <tr> <td>0</td> <td>0</td> <td>0</td> <td>0</td> <td>1</td> <td>less than 4dB</td> </tr> <tr> <td>0</td> <td>0</td> <td>0</td> <td>1</td> <td>0</td> <td>3-8dB</td> </tr> <tr> <td>0</td> <td>0</td> <td>1</td> <td>0</td> <td>0</td> <td>8-14dB</td> </tr> <tr> <td>0</td> <td>1</td> <td>0</td> <td>0</td> <td>0</td> <td>14-20dB</td> </tr> <tr> <td>1</td> <td>0</td> <td>0</td> <td>0</td> <td>0</td> <td>more than 20dB</td> </tr> </tbody> </table>	PD4	PD3	PD2	PD1	PD0	Line Attenuation	0	0	0	0	1	less than 4dB	0	0	0	1	0	3-8dB	0	0	1	0	0	8-14dB	0	1	0	0	0	14-20dB	1	0	0	0	0	more than 20dB
PD4	PD3	PD2	PD1	PD0	Line Attenuation																																	
0	0	0	0	1	less than 4dB																																	
0	0	0	1	0	3-8dB																																	
0	0	1	0	0	8-14dB																																	
0	1	0	0	0	14-20dB																																	
1	0	0	0	0	more than 20dB																																	
2	LLOS	<p><b>LIU Loss of Signal indication.</b> This bit will be high if the received signal is below the threshold selected by ELOS (page 2, address 10H) for a period of at least 1 msec. This bit will be low for normal operation.</p>																																				
1-0	---	Unused																																				

Table 109 - Receive Signal Status Word (Page 3, Address 16H) (E1)

Bit	Name	Functional Description
7	JACS	<p><b>Jitter Attenuated Clock Slow.</b> If one it indicates that the dejittered clock period is increased by 1/16 UI. If zero the clock is at normal speed.</p>
6	JACF	<p><b>Jitter Attenuated Clock Fast.</b> If one it indicates that the dejittered clock period is decreased by 1/16 UI. If zero the clock is at normal speed.</p>
5	JAE	<p><b>Jitter Attenuator FIFO Empty.</b> If one it indicates that the JA FIFO is empty.</p>
4	JAF4	<p><b>Jitter Attenuator FIFO with 4 Full Locations.</b> If one it indicates that the JA FIFO has at least 4 full locations.</p>
3	J AFC	<p><b>Jitter Attenuator Center Full.</b> If one it indicates that the JA FIFO is at least half full.</p>
2	JAE4	<p><b>Jitter Attenuator FIFO with 4 Empty Locations.</b> If one it indicates that the JA FIFO has at most 4 empty locations.</p>
1	JAF	<p><b>Jitter Attenuator FIFO Full.</b> If one it indicates that the JA FIFO is full.</p>
0	---	Unused.

Table 110 - Jitter Attenuator Status Word (Page 3, Address 17H) (E1)

Bit	Name	Functional Description
7	RIU1	<p><b>Receive International Use 1.</b> This bit is received on the PCM 30 2048 kbit/sec. link in bit position one of the non-frame alignment signal. It is used for CRC-4 multiframe alignment or international use.</p>
6	RNFAB	<p><b>Receive Non-frame Alignment Bit.</b> This bit is received on the PCM 30 2048 kbit/sec. link in bit position two of the non-frame alignment signal. This bit should be one in order to differentiate between frame alignment frames and non-frame alignment frames.</p>
5	RALM	<p><b>Receive Alarm.</b> This bit is received on the PCM 30 2048 kbit/sec. link in bit position three (the A bit) of the non-frame alignment signal. It is used as a remote alarm indication (RAI) from the far end of the PCM 30 link (1 - alarm, 0 - normal).</p>
4-0	RNU4-8	<p><b>Receive National Use Four to Eight.</b> These bits are received on the PCM 30 2048 kbit/sec. link in bit positions four to eight (the Sa bits) of the non-frame alignment signal.</p>

Table 111 - Receive Non-Frame Alignment Signal (Page 3, Address 18H) (E1)

Bit	Name	Functional Description
7-4	RMAI1-4	<b>Receive Multiframe Alignment Bits One to Four.</b> These bits are received on the PCM 30 2048 kbit/sec. link in bit positions one to four of time slot 16 of frame zero of every signalling multiframe. These bit should be 0000 for proper signalling multiframe alignment.
3	X1	<b>Receive Spare Bit X1.</b> This bit is received on the PCM 30 2048 kbit/sec. link in bit position five of time slot 16 of frame zero of every signalling multiframe.
2	Y	<b>Receive Y-bit.</b> This bit is received on the PCM 30 2048 kbit/sec. link in bit position six of time slot 16 of frame zero of every signalling multiframe. The Y bit may indicate loss of multiframe alignment at the remote end (1 -loss of multiframe alignment; 0 - multiframe alignment acquired).
1-0	X2, X3	<b>Receive Spare Bits X2 and X3.</b> These bits are received on the PCM 30 2048 kbit/sec. link in bit positions seven and eight respectively, of time slot 16 of frame zero of every signalling multiframe.

**Table 112 - Receive Multiframe Alignment Signal (Page 3, Address 19H) (E1)**

Bit	Name	Functional Description
7	RAIS	<b>Remote Alarm Indication Status.</b> If one, there is currently a remote alarm condition (i.e., received A bit is one). If zero, normal operation. Updated on a non-frame alignment frame basis.
6	AISS	<b>Alarm Indication Status Signal.</b> If one, indicates that a valid AIS or all ones signal is being received. If zero, indicates that a valid AIS signal is not being received. The criteria for AIS detection is determined by the control bit ASEL.

**Table 113 - Alarm Status Word 2 (Page 3, Address 1BH) (E1)**

Bit	Name	Functional Description
5	AIS16S	<b>Alarm Indication Signal 16 Status.</b> If one, indicates an all ones alarm is being received in channel 16. If zero, normal operation. Updated on a frame basis.
4	LOSS	<b>Loss of Signal Status.</b> If one, indicates the presence of a loss of signal condition. If zero, indicates normal operation. A loss of signal condition occurs when 192 consecutive bit periods are zero. A loss of signal condition terminates when an average ones density of at least 12.5% has been received over a period of 192 contiguous pulse positions starting with a pulse.
3	AUXPS	<b>Auxiliary Pattern Status.</b> This bit goes high when a continuous 101010... bit stream (Auxiliary Pattern) is received on the PCM 30 link for a period of at least 512 bits. If zero, auxiliary pattern is not being received. This pattern will be decoded in the presence of a bit error rate of as much as 10-3.
2	MFALMS	<b>Multiframe Alarm Status.</b> This bit goes high in the event of receipt of a multiframe alarm. It goes low when the received multiframe alarm bit goes low.
1	RSLIPS	<b>Receive Slip Status.</b> A change of state (i.e., 1-to-0 or 0-to-1) indicates that a receive controlled frame slip has occurred.
0	---	<b>Unused.</b>

**Table 113 - Alarm Status Word 2 (Page 3, Address 1BH) (E1)**

Bit	Name	Functional Description
7-0	ID7-0	<b>ID Number.</b> Contains device code 10101111

**Table 114 - Identification Word (Page 3, Address 1FH) (E1)**

**Master Status 2 (Page-4)**

**Master Status 2 (Page 04H) (E1)**

<b>Address (A<sub>4</sub>A<sub>3</sub>A<sub>2</sub>A<sub>1</sub>A<sub>0</sub>)</b>	<b>Register</b>	<b>Function</b>
10H (Table 116)	PRBS Error Counter	PS7-0
11H (Table 117)	CRC Multiframe counter for PRBS	PSM7-0
12H (Table 118)	Alarm Reporting Latch	RAI, AIS, AIS16, LOS, AUXP, MFALM, RSLIP
13H (Table 119)	Framing Bit Counter	EFAS7-0
14H (Table 120)	E-bit Error Counter Ebt	EC9-EC8
15H (Table 121)	E-bit Error Counter Ebt	EC7-EC0
16H (Table 122)	Most Significant Bipolar Violation Error Counter	BPV15 - BPV8
17H (Table 123)	Least Significant Bipolar Violation Error Counter	BPV7 - BPV0
18H (Table 124)	CRC- 4 Error Counter CEt	CC9-CC8
19H (Table 125)	CRC- 4 Error Counter CEt	CC7 - CC0
1AH		Unused.
1BH (Table 126)	Interrupt Word Zero	TFSYNI, MFSYNI, AISI, LOSI, CEF,Y, RxSLPI
1CH (Table 127)	Interrupt Word One	RAII,AUXPI,PRBSERRI,BPVI,AIS16I,EBITI, CRCERRI, FERRI
1DH (Table 128)	Interrupt Word Two	FERRO,CRCO,FECEO,BPVO,PRBSO,PRBSMFO
1EH (Table 129)	Interrupt Word Three	HDLC0I,HDLC1I,JAII,1SECI,5SECI,RCRI,SIGI
1FH (Table 130)	Overflow Reporting Latch	FERROL,CRCOL,FEBOI,BPVOL, PRBSOL, PRBSMFOFOL

**Table 115 - Master Status 2 (Page 4) (E1)**



Bit	Name	Functional Description
7 - 0	PS7-0	This counter is incremented for each PRBS error detected on any of the receive channels connected to the PRBS error detector.

**Table 116 - PRBS Error Counter  
(Page 4, Address 10H) (E1)**

Bit	Name	Functional Description
7 - 0	PSM7-0	This counter is incremented for each received CRC multiframe. It is cleared when the PRBS Error Counter is written to.

**Table 117 - CRC Multiframe Counter for PRBS  
(Page 4, Address 11H) (E1)**

Bit	Name	Functional Description
7	RAI	<b>Remote Alarm Indication.</b> This bit is set to one in the event of receipt of a remote alarm, i.e. $A(\text{RAI}) = 1$ . It is cleared when the register is read.
6	AIS	<b>Alarm Indication Signal.</b> This bit is set to one in the event of receipt of an all ones alarm. It is cleared when the register is read.
5	AIS16	<b>AIS Time Slot 16 Alarm.</b> This bit is set to one in the event of receipt of an all ones alarm in the time slot 16. It is cleared when the register is read.
4	LOS	<b>Loss of Signal.</b> This bit is set to one in the event of digital loss of received signal. It is cleared when the register is read.
3	AUXP	<b>Auxiliary Alarm.</b> This bit is set to one in the event of receipt of the auxiliary alarm pattern. It is cleared when the register is read.
2	MFALM	<b>Multiframe Alarm.</b> This bit is set to one in the event of receipt of a multiframe alarm. It is cleared when the register is read.
1	RSLIP	<b>Received Slip.</b> This bit is set to one in the event of receive elastic buffer slip. It is cleared when the register is read.
0	---	<b>Unused.</b>

**Table 118 - Alarm Reporting Latch  
(Page 4, Address 12H) (E1)**

Bit	Name	Functional Description
7 - 0	EFAS7 - 0	<b>Errored FAS Counter.</b> An 8 bit counter that is incremented once for every receive frame alignment signal that contains one or more errors.

**Table 119 - Errored Frame Alignment Signal Counter  
(Page 4, Address 13H) (E1)**

Bit	Name	Functional Description
7-2	---	Unused
1-0	EC9-8	<b>E bit Error Counter.</b> The most significant 2 bits of the E bit error counter.

**Table 120 - E-bit Error Counter**  
(Page 4, Address 14H) (E1)

Bit	Name	Functional Description
7 - 0	EC7-0	<b>E bit Error Counter.</b> The least significant 8 bits of the E-bit error counter.

**Table 121 - E-bit Error Counter**  
(Page 4, Address 15H) (E1)

Bit	Name	Functional Description
7 - 0	BPV15 - 8	<b>Most Significant Bits of the BPV Counter.</b> The most significant eight bits of a 16 bit counter that is incremented once for every bipolar violation error received.

**Table 122 - Most Significant Bits of the BPV Counter**  
(Page 4, Address 16H) (E1)

Bit	Name	Functional Description
7 - 0	BPV7 - 0	<b>Least Significant Bits of the BPV Counter.</b> The least significant eight bits of a 16 bit counter that is incremented once for every bipolar violation error received.

**Table 123 - Least Significant Bits of the BPV Counter**  
(Page 4, Address 17H) (E1)

Bit	Name	Functional Description
7-2	---	Unused
1-0	CC9 - 8	<b>CRC-4 Error Counter</b> These are the most significant eight bits of the CRC-64error counter.

**Table 124 - CRC-4 Error Counter CEt**  
(Page 4, Address 18H) (E1)

Bit	Name	Functional Description
7 - 0	CC7 - 0	<b>CRC-4 Error Counter.</b> These are the least significant eight bits of the CRC-4 error counter.

**Table 125 - CRC-4 Error Counter CEt**  
(Page 4, Address 19H) (E1)

Bit	Name	Functional Description
7	TFSYNI	<b>Terminal Frame Synchronization Interrupt.</b> When unmasked this interrupt bit goes high whenever a change of state of terminal frame synchronization condition exists. Reading this register clears this bit.
6	MFSYNI	<b>Multiframe Synchronization Interrupt.</b> When unmasked this interrupt bit goes high whenever a change of state of multiframe synchronization condition exists. Reading this register clears this bit.
5	CRCSYNI	<b>CRC-4 Synchronization Interrupt.</b> When unmasked this interrupt bit goes high whenever change of state of CRC-4 synchronization condition exists. Reading this register clears this bit.
4	AISI	<b>Alarm Indication Signal Interrupt.</b> When unmasked this interrupt bit goes high whenever a change of state of received all ones condition exists. Reading this register clears this bit.

**Table 126 - Interrupt Word Zero**  
(Page 4, Address 1BH) (E1)

Bit	Name	Functional Description
3	LOSI	<b>Loss of Signal Interrupt.</b> When unmasked this interrupt bit goes high whenever a loss of signal (either analog - received signal 20 or 40 dB below nominal or digital - 192 consecutive 0's received) condition exists.
2	CEFI	<b>Consecutively Errored Frame Alignment Interrupt.</b> When unmasked this interrupt bit goes high whenever the error in last two frame alignment signals occurs. Reading this register clears this bit.
1	YI	<b>Receive Y-bit Interrupt.</b> When unmasked this interrupt goes high whenever a change of status loss of multiframe alignment occurs. Reading this register clears this bit.
0	RxSLPI	<b>Receive SLIP Interrupt.</b> When unmasked this interrupt bit goes high whenever a controlled frame slip occurs in the receive elastic buffer. Reading this register clears this bit.

**Table 126 - Interrupt Word Zero  
(Page 4, Address 1BH) (E1)**

Bit	Name	Functional Description
7	FERRI	<b>Errored Framing Alignment Signal Interrupt.</b> When unmasked this interrupt bit goes high whenever an erroneous bit in frame alignment signal is detected (provided the circuit is in terminal frame sync). Reading this register clears this bit.
6	CRCEERRI	<b>CRC-4 Error Interrupt.</b> When unmasked this interrupt bit goes high whenever a local CRC-4 error occurs. Reading this register clears this bit.
5	EBITI	<b>Receive E-bit Error Interrupt.</b> When unmasked this interrupt bit goes high upon detection of a wrong E-bit in multiframe. Reading this register clears this bit.
4	AIS16I	<b>Alarm Indication Signal Interrupt.</b> When unmasked this interrupt bit goes high whenever all ones in time slot 16 occur. Reading this register clears this bit.
3	BPVI	<b>Bipolar Violation Interrupt.</b> When unmasked this interrupt bit goes high whenever a bipolar violation (excluding HDB3 encoding) is encountered. Reading this register clears this bit.
2	PRBSERRI	<b>Pseudo Random Bit Sequence Error Interrupt.</b> When unmasked this interrupt bit goes high upon detection of an error with a channel selected for PRBS testing. Reading this register clears this bit.
1	AUXPI	<b>Auxiliary Pattern Alarm Interrupt.</b> When unmasked this interrupt bit goes high whenever a sequence of 512 bit consecutive 101010. occur. Reading this register clears this bit.
0	RAII	<b>Remote alarm Indication Interrupt.</b> When unmasked this interrupt bit goes high whenever the bit 3 of non-frame alignment signal is high. Reading this register clears this bit.

**Table 127 - Interrupt Word One  
(Page 4, Address 1CH) (E1)**

Bit	Name	Functional Description
7	FERRO	<b>Errorred Framing Alignment Signal Counter Overflow Interrupt.</b> When unmasked this interrupt bit goes high whenever the errored frame alignment signal counter changes from FFH to 00H. Reading this register clears this bit.
6	CRCO	<b>CRC Error Counter Overflow Interrupt.</b> When unmasked this interrupt bit goes high whenever the CRC error counter changes from FFH to 00H. Reading this register clears this bit.
5	FECEO	<b>E-bit Counter Overflow Interrupt.</b> When unmasked this interrupt bit goes high whenever the E-bit counter changes from FFH to 00H. Reading this register clears this bit.
4	---	<b>Unused</b>
3	BPVO	<b>Bipolar Violation Counter Overflow Interrupt.</b> When unmasked this interrupt bit goes high whenever the bipolar violation counter changes from FFH to 00H. Reading this register clears this bit.
2	PRBSO	<b>Pseudo Random Bit Sequence Error Counter Overflow Interrupt.</b> When unmasked this interrupt bit goes high whenever the PRBS error counter changes from FFH to 00H. Reading this register clears this bit.
1	PRBSMFO	<b>Pseudo Random Bit Sequence Multiframe Counter Overflow Interrupt.</b> When unmasked this interrupt bit goes high whenever the multiframe counter attached to the PRBS error counter overflows. FFH to 00H. 1 - unmasked, 0 - masked.
0	---	<b>Unused</b>

**Table 128 - Interrupt Word Two (Page 4, Address 1DH) (E1)**

Bit	Name	Functional Description
7	---	<b>Unused</b>
6	HDLC0I	<b>HDLC0 Interrupt.</b> Whenever an unmasked HDLC0 interrupt occurs. This bit goes high. Reading this register clears this bit.
5	HDLC1I	<b>HDLC1 Interrupt.</b> Whenever an unmasked HDLC1 interrupt occurs. this bit goes high. Reading this register clears this bit.
4	JAI	<b>Jitter Attenuator Error Interrupt.</b> Whenever an unmasked JAI interrupt occurs. If jitter attenuator FIFO comes within four bytes of an overflow or underflow, this bit goes high. Reading this register clears this bit.
3	1SECI	<b>One Second Status Interrupt.</b> When unmasked this interrupt bit goes high whenever the 1SEC status bit (page 3 address 12H bit 7) goes from low to high. Reading this register clears this bit.
2	5SECI	<b>Five Second Status Interrupt.</b> When unmasked this interrupt bit goes high whenever the 5 SEC status bit goes from low to high. Reading this register clears this bit.
1	RCRI	<b>RCRI Interrupt.</b> Whenever an unmasked RCRI interrupt occurs. If remote alarm and CRC error occur this bit goes high. Reading this register clears this bit.
0	SIGI	<b>Signalling Interrupt.</b> When unmasked this interrupt bit goes high whenever a change of state (optionally debounced - see DBEn in the Data Link, Signalling Control Word) is detected in the signalling bits (AB or ABCD) pattern. Reading this register clears this bit.

**Table 129 - Interrupt Word Three (Page 4, Address 1EH) (E1)**

Bit	Name	Functional Description
7	FERROL	<b>Errorred Frame Alignment Signal Counter Overflow Latch.</b> This bit is set when the errored frame alignment signal counter overflows. It is cleared after being read.
6	CRCOL	<b>CRC Error Counter Overflow Latch.</b> This bit is set when the crc error counter overflows. It is cleared after being read.
5	FEBOOL	<b>E bit Counter Overflow Latch.</b> This bit is set when E bit counter overflows. It is cleared after being read.
4	---	
3	BPVOL	<b>Bipolar Violation Counter Overflow Latch.</b> This bit is set when the bipolar violation counter overflows. It is cleared after being read.
2	PRBSOL	<b>Pseudo Random Bit Sequence Error Counter Overflow Latch.</b> This bit is set when the PRBS error counter overflows. It is cleared after being read.
1	PRBSM FOFOL	<b>Pseudo Random Bit Sequence Multiframe Counter Overflow Latch.</b> This bit is set when the multiframe counter attached to the PRBS error counter overflows. It is cleared after being read
0	---	<b>Unused.</b>

**Table 130 - Overflow Reporting Latch  
(Page 4, Address 1FH) (E1)**

**Per Channel Transmit Signalling (Pages 5 and 6) (E1)**

Page 05H, addresses 10000 to 11111, and page 06H addresses 10000 to 10111 contain the Transmit Signalling Control Words for Channel Associated Signalling (CAS) channels 2 to 16 and 18 to 32 respectively. Table 132 illustrates the mapping between the addresses of these pages and the CAS channel numbers. Control of these bits for any one channel is through the processor or controller port when the Per Time Slot Control bit RPSIG bit is high. Table 133 describes bit allocation within each of these registers.

Page 5 Address:	0	1	2	3	4	5	6	7	8	9	10	11	12	13	14	15
Equivalent CAS channel	1	2	3	4	5	6	7	8	9	10	11	12	13	14	15	16
Page 6 Address:	0	1	2	3	4	5	6	7	8	9	10	11	12	13	14	15
Equivalent CAS channel	17	18	19	20	21	22	23	24	25	26	27	28	29	30	31	32

**Table 131 - Page 5, 6 Address Mapping to CAS Signalling Channels (E1)**

Bit	Name	Functional Description
7 - 4	---	<b>Unused.</b>
3 - 0	A(n) B(n) C(n) D(n)	<b>Transmit Signalling Bits for Channel n.</b> These bits are transmitted on the PCM 30 2048 kbit/sec. Link in bit positions one to four of time slot 16 in frame n (when n = 1 to 15), and are the A, B, C, D signaling bits associated with channel n.

**Table 132 - Transmit Channel Associated Signalling (E1) (Pages 5,6)**

Serial per channel transmit signalling control through CSTI is selected when RPSIG bit is zero. Table 132 describes the function of CSTI time slots 1 to 30. if MSN bit is high, CSTI time slots 17 to 31 are selected. if MSN bit is low, CSTI time slots 1 to 15 are selected.

Bit	Name	Functional Description
7 - 4	A(n), B(n), C(n), D(n)	<b>Transmit Signalling Bits for Channel n.</b> These bits are transmitted on the PCM 30 2048 kbit/sec. Link in bit positions one to four of time slot 16 in frame n (where n = 1 to 15), and are the A, B, C, D signalling bits associated with channel n.
3 - 0	A(n), B(n), C(n), D(n)	<b>Transmit Signalling Bits for Channel n.</b> These bits are transmitted on the PCM 30 2048 kbit/sec. Link in bit positions one to four of time slot 16 in frame n (where n = 1 to 15), and are the A, B, C, D signalling bits associated with channel n.

**Table 133 - E1 / Transmit Channels Usage - CSTi**

NOTE: This table illustrates bit mapping on the serial input stream - it does not refer to an internal register.

**Per Time Slot Control Words(Pages 7 and 8) (E1)**

The control functions described by Table 135 are repeated for each PCM-30 channel. Page 07H addresses 10H to 1FH correspond to time slots 0 to 15, while page 08H addresses 10H to 1FH correspond to time slots 16 to 31. Table 136 illustrates the mapping between the addresses of these pages and the CEPT channel numbers.

Page 8H Address:	0	1	2	3	4	5	6	7	8	9	10	11	12	13	14	15	
Equivalent PCM Timeslots	30	0	1	2	3	4	5	6	7	8	9	10	11	12	13	14	15
Page 9H Address:	0	1	2	3	4	5	6	7	8	9	10	11	12	13	14	15	
Equivalent PCM Timeslots	30	16	17	18	19	20	21	22	23	24	25	26	27	28	29	30	31

**Table 134 - Mapping to CEPT Channels(Page 8H and 9H) (E1)**



Bit	Name	Functional Description
7	TXMSG	<b>Transmit Message Mode.</b> If high, the data from the corresponding address location of Tx message mode buffer is transmitted in the corresponding PCM 30 time slot. If zero, the data on DSTI is transmitted on the corresponding PCM 30 time slot.
6	ADI	<b>Alternate Digit Inversion.</b> If one, the corresponding transmit time slot data on DSTI has every second bit inverted. If zero, this bit has no effect on channel data.
5	RTSL	<b>Remote Time Slot Loopback.</b> If one, the corresponding PCM 30 receive time slot is looped to the corresponding PCM 30 transmit time slot. This received time slot will also be present on DSTO. If zero, the loopback is disabled.
4	LTSL	<b>Local Time Slot Loopback.</b> If one, the corresponding transmit time slot is looped to the corresponding receive time slot. This transmit time slot will also be present on the transmit PCM 30 stream. If zero, this loopback is disabled.
3	TTST	<b>Transmit Test.</b> If one, a test signal, either digital milliwatt (when control bit ADSEQ is one) or PRBS ( $2^{15}-1$ ) (ADSEQ is zero), will be transmitted in the corresponding PCM 30 time slot. More than one time slot may be activated at once. If zero, the test signal will not be connected to the corresponding time slot.
2	RTST	<b>Receive Test.</b> If one, the corresponding DSTo time slot will be used for testing. If control bit ADSEQ is one, a digital milliwatt signal will be transmitted into the DSTo channel. If ADSEQ is zero, the receive channel will be connected to the PRBS ( $2^{15}-1$ ) detector
1	RPSIG	<b>Serial Signaling Enable.</b> If one, the transmit CAS signalling will be controlled by programming Page 05H. If zero, the transmit CAS signalling will be controlled through the CSTI stream.
0	---	<b>Unused.</b>

Table 135 - Per Time Slot Control Words (Pages 7 and 8) (E1)

**Per Channel Receive Signalling (Pages 9 and 0AH) (E1)**

Page 09H, addresses 10001 to 11111, and page 1AH addresses 10001 to 11111 contain the Receive Signalling Control Words for CAS channels 2 to 16 and 18 to 32. Table 137 illustrates the mapping between the addresses of these pages and the CAS channel numbers. Table 138 describes bit allocation within each of these registers.

Page 9 Address:	0	1	2	3	4	5	6	7	8	9	10	11	12	13	14	15
Equivalent PCM 30 Timeslots	0	1	2	3	4	5	6	7	8	9	10	11	12	13	14	15
Page A Address:	0	1	2	3	4	5	6	7	8	9	10	11	12	13	14	15
Equivalent PCM 30 Timeslots	16	17	18	19	20	21	22	23	24	25	26	27	28	29	30	31

**Table 136 - Page 9, A Address Mapping to CAS Channels (E1)**

Bit	Name	Functional Description
7 - 4	- - -	<b>Unused</b>
3 - 0	A(n) B(n) C(n) D(n)	<b>Receive Signalling Bits for Channel n.</b> These bits are received on the PCM 30 2048 kbit/sec. Link in bit positions one to four of time slot 16 in frame n (where n = 1 to 30) and are the A, B, C, D signalling bits associated with channel n.

**Table 137 - Receive Channel Associated Signalling (Pages 9 and A) (E1)**

Serial per channel receive signalling status bits appear on ST-BUS stream CSTo. Table 139 describes the bit allocation within each of the 30 active ST-BUS time slot of CSTo.

Bit	Name	Functional Description
7 - 4	A(n), B(n), C(n), D(n)	<b>Transmit Signalling Bits for Channel n.</b> These bits are transmitted on the PCM 30 2048 kbit/sec. Link in bit positions one to four of time slot 16 in frame n (where n = 1 to 15), and are the A, B, C, D signalling bits associated with channel n.
3 - 0	A(n), B(n), C(n), D(n)	<b>Transmit Signalling Bits for Channel n.</b> These bits are transmitted on the PCM 30 2048 kbit/sec. Link in bit positions one to four of time slot 16 in frame n (where n = 1 to 15), and are the A, B, C, D signalling bits associated with channel n.

**Table 138 - Receive CAS Channels (CSTo) (E1)**

HDLC Control and Status (Page B for HDLC0 and Page C for HDLC1)

Address	Register		Function
	Control (Write/Verify)	Status (Read)	
10H(Table 140)	Address Recognition 1	---	ADR16-10,A1EN
11H(Table 141)	Address Recognition 2	---	ADR26-20, A2EN
12H (Table 142/143)	TX FIFO	RX FIFO	BIT7-0
13H(Table 144)	HDLC Control 1	---	ADREC, RxEN, TxEN, EOP, FA, Mark- idle,TR, FRUN
14H(Table 145)	---	HDLC Status	INTGEN, Idle-Chan, RQ9, RQ8, TxSTAT2, TxSTAT1, RxSTAT2, RxSTAT1
15H(Table 146)	HDLC Control 2	---	INTSEL, CYCLE, TxCRCL, SEVEN,RxFRST, TxFRST
16H(Table 147)	Interrupt Mask	---	GaIM, RxEOPIM, TxEOPIM, RxFEIM, TxFLIM, FA:TxUNDERIM, RxFFIM, RxOVFIM
17H(Table 148)	---	Interrupt Status (*)	Ga, RxEOP, TxEOP, RxFE, TxFL, FA:TxUNDER, RxFF, RxOVF
18H(Table 149)	---	Rx CRC MSB	CRC15-CRC8
19H(Table 150)	---	Rx CRC LSB	CRC7-CRC0
1AH(Table 151)	TX byte count	---	TxCNT7-0
1BH(Table 152)	Test Control	---	HRST, RTLOOP, CRCTST, FTST, ARTST, HLOOP
1CH(Table 153)	---	Test Status	RxCLK, TxCLK, VCRC, VADDR
1DH(Table 154)	HDLC Control 3	---	RSV, RFD2-0,RSV, TFD2-0
1EH(Table 155)	HDLC Control 4	---	RSV, RFFS2-0, RSV, TFLS2-0

Table 139 - HDLC 0 & 1 Control and Status (Page B & C)

Bit	Name	Functional Description
7 - 2	ADR16-11	Address 16 - 11. A six bit address used for comparison with the first byte of the received address. ADR16 is MSB.
1	ADR10	Address 10. This bit is used in address comparison if a seven bit address is being checked for (control bit four of control register 2 is set).
0	A1EN	First Address Comparison Enable. When this bit is high, the above six (or seven) bit address is used in the comparison of the first address byte. If address recognition is enabled, any packet failing the address comparison will not be stored in the RX FIFO. A1EN must be high for All-call (1111111) address recognition for single byte address. When this bit is low, this bit mask is ignored in address comparison

**Table 140 - HDLC Address Recognition Register 1**  
(Page B & C, Address 10H)

Bit	Name	Functional Description
7 - 0	BIT7-0	This eight bit word is tagged with the two status bits from the control register 1 (EOP and FA), and the resulting 10 bit word is written to the TX FIFO. The FIFO status is not changed immediately after a write or read occurs. It is updated after the data has settled and the transfer to the last available position has finished.

**Table 142 - TX FIFO Write Register**  
(Page B & C, Address 12H)

Bit	Name	Functional Description
7 - 0	BIT7-0	This is the received data byte read from the RX FIFO. The status bits of this byte can be read from the status register. The FIFO status is not changed immediately when a write or read occurs. It is updated after the data has settled and the transfer to the last available position has finished.

**Table 143 - RX FIFO Read Register**  
(Page B & C, Address 12H)

Bit	Name	Functional Description
7 - 1	ADR26-20	Address 26 - 20. A seven bit address used for comparison with the second byte of the received address. ADR26 is MSB. This mask is ignored (as well as first byte mask) if all call address (1111111) is received.
0	A2EN	Second Address Comparison Enable. When this bit is set high, the above seven bit address is used in the comparison of the second address byte. If address recognition is enabled, any packet failing the address comparison will not be stored in the RX FIFO. A2EN must be high for All-call address recognition. When this bit is low, this bit mask is ignored in address comparison

**Table 141 - HDLC Address Recognition Register2**  
(Page B & C, Address 11H)

Bit	Name	Functional Description
7	ADREC	When high this bit will enable address recognition. This forces the receiver to recognize only those packets having the unique address as programmed in the Receive Address Recognition Registers or if the address is an All call address.
6	RxEN	When low this bit will disable the HDLC receiver. The receiver will disable after the rest of the packet presently being received is finished. The receiver internal clock is disabled. When high the receiver will be immediately enabled and will begin searching for flags, Go-aheads etc.
5	TxEN	When low this bit will disable the HDLC transmitter. The transmitter will disable after the completion of the packet presently being transmitted. The transmitter internal clock is disabled. When high the transmitter will be immediately enabled and will begin transmitting data, if any, or go to a mark idle or interframe time fill state.
4	EOP	Forms a tag on the next byte written the TX FIFO, and when set will indicate an end of packet byte to the transmitter, which will transmit an FCS following this byte. This facilitates loading of multiple packets into TX FIFO. Reset automatically after a write to the TX FIFO occurs.
3	FA	Forms a tag on the next byte written to the TX FIFO, and when set will indicate to the transmitter that it should abort the packet in which that byte is being transmitted. Reset automatically after a write to the TX FIFO.

**Table 144 - HDLC Control register 1  
(Page B & C, Address 13H)**

Bit	Name	Functional Description
2	Mark-Idle	When low, the transmitter will be in an idle state. When high it is in an interframe time fill state. These two states will only occur when the TX FIFO is empty.
1	TR	When high this bit will enable transparent mode. This will perform the parallel to serial conversion without inserting or deleting zeros. No CRC bytes are sent or monitored nor are flags or aborts. A falling edge of TxEN for transmit and a falling edge of RxEN for receive is necessary to initialize transparent mode. This will also synchronize the data to the transmit and receive channel structure. Also, the transmitter must be enabled through control register 1 before transparent mode is entered.
0	FRUN	When high the HDLC TX and RX are continuously enabled providing the RxEN and TxEN bits are set

**Table 144 - HDLC Control register 1  
(Page B & C, Address 13H)**

Bit	Name	Functional Description
7	INTGEN	Interrupt Generated. Set to 1 when an interrupt (in conjunction with the Interrupt Mask Register) has been generated by the HDLC. This is an asynchronous event. It is reset when the interrupt Register is read.
6	Idle Chan	Idle Channel. Set to a 1 when an idle Channel state (15 or more ones) has been detected at the receiver. This is an asynchronous event. On power reset, this may be 1 if the clock (RXC) was not operating. Status becomes valid after the first 15 bits or the first zero is received.
5 - 4	RQ9, RQ8	Byte Status bits from RX FIFO. These bits determine the status of the byte to be read from RX FIFO as follows: RQ9 RQ8 Byte Status 0 0 Packet Byte 0 1 First Byte 1 0 Last byte of a good packet. 1 1 Last byte of a bad packet.
3 - 2	TxSTAT2-1	These bits determine the status of the TX FIFO as follows: TxSTAT2 TxSTAT1 TX FIFO Status 0 0 TX FIFO full up to the selected status level or more. 0 1 The number of bytes in the TX FIFO has reached or exceeded the selected interrupt threshold level. 1 0 TX FIFO empty. 1 1 The number of bytes in the TX FIFO is less than the selected interrupt threshold level.
1 - 0	RxSTAT2 - 1	These bits determine the status of the RX FIFO as follows: RxSTAT2 RxSTAT1 RX FIFO Status 0 0 RX FIFO empty 0 1 The number of bytes in the RX FIFO is less than the interrupt threshold level. 1 0 RX FIFO full. 1 1 The number of bytes in the RX FIFO has reached or exceeded the interrupt threshold level.

**Table 145 - HDLC Status Register  
(Page B & C Address 14H)**

Bit	Name	Functional Description
7	INTSEL	<b>Interrupt Selection.</b> When high, this bit will cause bit 2 of the Interrupt Register to reflect a TX FIFO underrun (TXunder). When low, this interrupt will reflect a frame abort (FA).
6	CYCLE	<b>Cycle.</b> When high, this bit will cause the transmit byte count to cycle through the value loaded into the Transmit Byte Count Register.
5	TxCRCI	<b>Transmit CRC Inhibited.</b> When high, this bit will inhibit transmission of the CRC. That is, the transmitter will not insert the computed CRC onto the bit stream after seeing the EOP tag byte. This is used in V.120 terminal adaptation for synchronous protocol sensitive UI frames.
4	SEVEN	<b>Seven Bit Address Recognition.</b> When high, this bit will enable seven bits of address recognition in the first address byte. The received address byte must have bit 0 equal to 1 which indicates a single address byte is being received.
3	RSV	<b>Reserved,</b> must be zero for normal operation.
2	RSV	<b>Reserved,</b> must be zero for normal operation.
1	RxFRST	<b>RX FIFO Reset.</b> When high, the RX FIFO will be reset. This causes the receiver to be disabled until the next reception of a flag. The status register will identify the FIFO as being empty. However, the actual bit values in the RX FIFO will not be reset.
0	TxFRST	<b>TX FIFO Reset.</b> When high, the TX FIFO will be reset. The Status Register will identify the FIFO as being empty. This bit will be reset when data is written to the TX FIFO. However, the actual bit values of data in the TX FIFO will not be reset. It is cleared by the next write to the TX FIFO.

**Table 146 - HDLC Control Register 2 (Page B & C, Address 15H)**

Bit	Name	Functional Description
7-0	GalM RxEOPIM TxEOPIM RxFEIM TxFLIM FA:TxUNDE RIMRxFFIM RxOVFIM	This register is used with the Interrupt Register to mask out the interrupts that are not required by the microprocessor. Interrupts that are masked out will not drive the pin $\overline{IRQ}$ low; however, they will set the appropriate bit in the Interrupt Register. An interrupt is disabled when the microprocessor writes a 0 to a bit in this register.  This register is cleared on power reset.

**Table 147 - HDLC Interrupt Mask Register (Page B & C, Address 16H)**



Bit	Name	Functional Description
7	GA	<b>Go Ahead.</b> Indicates a go-ahead pattern was detected by the HDLC receiver. This bit is reset after a read.
6	RxEOP	<b>End Of Packet Detected.</b> This bit is set when an end of packet (EOP) byte was written into the RX FIFO by the HDLC receiver. This can be in the form of a flag, an abort sequence or as an invalid packet. This bit is reset after a read.
5	TxEOP	<b>Transmit End Of Packet.</b> This bit is set when the transmitter has finished sending the closing flag of a packet or after a packet has been aborted. This bit is reset after read.
4	RxFE	<b>End Of Packet Read.</b> This bit is set when the byte about to be read from the RX FIFO is the last byte of the packet. It is also set if the Rx FIFO is read and there is no data in it. This bit is reset after a read.
3	TXFL	<b>TX FIFO Low.</b> This bit is set when the Tx FIFO is emptied below the selected low threshold level. This bit is reset after a read.
2	FA: TxUNDER	<b>Frame Abort/TX FIFO Under-run.</b> When Intsel bit of Control Register 2 is low, this bit (FA) is set when a frame abort is received during packet reception. It must be received after a minimum number of bits have been received (26) otherwise it is ignored.  When INTSEL bit of Control Register 2 is high, this bit is set for a TX FIFO underrun indication. If high it Indicates that a read by the transmitter was attempted on an empty Tx FIFO.  This bit is reset after a read.

**Table 148 - HDLC Interrupt Status Register  
(Page B & C, Address 17H)**

Bit	Name	Functional Description
1	RXFF	<b>RX FIFO Full.</b> This bit is set when the Rx FIFO is filled above the selected full threshold level. This bit is reset after a read.
0	RxOVF	<b>RX FIFO Overflow.</b> Indicates that the 128 byte RX FIFO overflowed (i.e. an attempt to write to a 128 byte full RX FIFO). The HDLC will always disable the receiver once the receive overflow has been detected. The receiver will be re-enabled upon detection of the next flag, but will overflow again unless the RX FIFO is read. This bit is reset after a read.

**Table 148 - HDLC Interrupt Status Register  
(Page B & C, Address 17H)**

Bit	Name	Functional Description
7-0	CRC1 5-8	<b>The MSB byte of the CRC received from the transmitter.</b> These bits are as the transmitter sent them; that is, most significant bit first and inverted. This register is updated at the end of each received packet and therefore should be read when end of packet is detected.

**Table 149 - Receive CRC MSB Register  
(Page B & C, Address 18H)**

Bit	Name	Functional Description
7-0	CRC7-0	<b>The LSB byte of the CRC received from the transmitter.</b> These bits are as the transmitter sent them; that is, most significant bit first and inverted. This register is updated at the end of each received packet and therefore should be read when end of packet is detected.

**Table 150 - Receive CRC LSB Register  
(Page B & C, Address 19H)**

Bit	Name	Functional Description
7-0s	TxCNT 7-0	<b>Transmit Byte Count Register.</b> The Transmit Byte Count Register indicating the length of the packet about to be transmitted. When this register reaches the count of one, the next write to the Tx FIFO will be tagged as an end of packet byte. The counter decrements at the end of the write to the Tx FIFO. If the Cycle bit of Control Register 2 is set high, the counter will cycle through the programmed value continuously.

**Table 151 - Transmit Byte Count Register (Page B & C, Address 1AH)**

Bit	Name	Functional Description
7	HRST	<b>HDLC Reset.</b> When this bit is set to one, the HDLC will be reset. This is similar to RESET being applied, the only difference being that this bit will not be reset. This bit can only be reset by writing a zero twice to this location or applying RESET.
6	RTLOOP	<b>RT Loopback.</b> When this bit is high, receive to transmit HDLC loopback will be activated. Receive data, including end of packet indication, but not including flags or CRC, will be written to the TX FIFO as well as the RX FIFO. When the transmitter is enabled, this data will be transmitted as though written by the microprocessor. Both good and bad packets will be looped back. Receive to transmit loopback may also be accomplished by reading the RX FIFO using the microprocessor and writing these bytes, with appropriate tags, into the TX FIFO.
5	RSV	<b>Reserved.</b> Must be set to 0 for normal operation.
4	RSV	<b>Reserved.</b> Must be set to 0 for normal operation.

**Table 152 - HDLC Test Control Register (Page B & C, Address 1BH)**

Bit	Name	Functional Description
3	CRCTST	<b>CRC Remainder Test.</b> This bit allows direct access to the CRC Comparison Register in the receiver through the serial interface. After testing is enabled, serial data is clocked in until the data aligns with the internal comparison (16 RXC clock cycles) and then the clock is stopped. The expected pattern is F0B8 hex. Each bit of the CRC can be corrupted to allow more efficient testing.
2	FTST	<b>FIFO Test.</b> This bit allows the writing to the RX FIFO and reading of the TX FIFO through the microprocessor to allow more efficient testing of the FIFO status/interrupt functionality. This is done by making a TX FIFO write become a RX FIFO write and a RX FIFO read become a TX FIFO read. In addition, EOP/FA and RQ8/RQ9 are re-defined to be accessible (i.e. RX write causes EOP/FA to go to RX fifo input; TX read looks at output of TX fifo through RQ8/RQ9 bits).
1	ARTST	<b>Address Recognition Test.</b> This bit allows direct access to the Address Recognition Registers in the receiver through the serial interface to allow more efficient testing. After address testing is enabled, serial data is clocked in until the data aligns with the internal address comparison (16 RXc clock cycles) and then clock is stopped.
0	HLOOP	<b>TR Loopback.</b> When high, transmit to receive HDLC loopback will be activated. The packetized transmit data will be looped back to the receive input. RXEN and TXEN bits must also be enabled.

**Table 152 - HDLC Test Control Register (Page B & C, Address 1BH)**

Bit	Name	Functional Description
7-4	RSV	These bits are reserved.
3	RxCLK	<b>Receive Clock.</b> This bit represents the receiver clock generated after the RXEN control bit, but before zero deletion is considered.
2	TxCLK	<b>Transmit Clock.</b> This bit represents the transmit clock generated after the TXEN control bit, but before zero insertion is considered.
1	VCRC	<b>Valid CRC.</b> This is the CRC recognition status bit for the receiver. Data is clocked into the register and then this bit is monitored to see if comparison was successful (bit will be high).
0	VADDR	<b>Valid Address.</b> This is the address recognition status bit for the receiver. Data is clocked into the Address Recognition Register and then this bit is monitored to see if comparison was successful (bit will be high).

**Table 153 - HDLC Test Status Register (Page B & C, Address 1CH)**

Bit	Name	Functional Description																																				
7	---	Unused.																																				
6-4	RFD2-0	These bits select the Rx FIFO full status level:																																				
		<table border="1"> <thead> <tr> <th>RF D2</th> <th>RF D1</th> <th>RF D0</th> <th>Full Status Level</th> </tr> </thead> <tbody> <tr> <td>0</td> <td>0</td> <td>0</td> <td>16</td> </tr> <tr> <td>0</td> <td>0</td> <td>1</td> <td>32</td> </tr> <tr> <td>0</td> <td>1</td> <td>0</td> <td>48</td> </tr> <tr> <td>0</td> <td>1</td> <td>1</td> <td>64</td> </tr> <tr> <td>1</td> <td>0</td> <td>0</td> <td>80</td> </tr> <tr> <td>1</td> <td>0</td> <td>1</td> <td>96</td> </tr> <tr> <td>1</td> <td>1</td> <td>0</td> <td>112</td> </tr> <tr> <td>1</td> <td>1</td> <td>1</td> <td>128</td> </tr> </tbody> </table>	RF D2	RF D1	RF D0	Full Status Level	0	0	0	16	0	0	1	32	0	1	0	48	0	1	1	64	1	0	0	80	1	0	1	96	1	1	0	112	1	1	1	128
		RF D2	RF D1	RF D0	Full Status Level																																	
		0	0	0	16																																	
		0	0	1	32																																	
		0	1	0	48																																	
		0	1	1	64																																	
		1	0	0	80																																	
		1	0	1	96																																	
1	1	0	112																																			
1	1	1	128																																			
3	---	Unused.																																				
2-0	TFD2-0	These bits select the Tx HDLC FIFO full status level:																																				
		<table border="1"> <thead> <tr> <th>TF D2</th> <th>TF D1</th> <th>TF D0</th> <th>Full Status Level</th> </tr> </thead> <tbody> <tr> <td>0</td> <td>0</td> <td>0</td> <td>16</td> </tr> <tr> <td>0</td> <td>0</td> <td>1</td> <td>32</td> </tr> <tr> <td>0</td> <td>1</td> <td>0</td> <td>48</td> </tr> <tr> <td>0</td> <td>1</td> <td>1</td> <td>64</td> </tr> <tr> <td>1</td> <td>0</td> <td>0</td> <td>80</td> </tr> <tr> <td>1</td> <td>0</td> <td>1</td> <td>96</td> </tr> <tr> <td>1</td> <td>1</td> <td>0</td> <td>112</td> </tr> <tr> <td>1</td> <td>1</td> <td>1</td> <td>128</td> </tr> </tbody> </table>	TF D2	TF D1	TF D0	Full Status Level	0	0	0	16	0	0	1	32	0	1	0	48	0	1	1	64	1	0	0	80	1	0	1	96	1	1	0	112	1	1	1	128
		TF D2	TF D1	TF D0	Full Status Level																																	
		0	0	0	16																																	
		0	0	1	32																																	
		0	1	0	48																																	
		0	1	1	64																																	
		1	0	0	80																																	
		1	0	1	96																																	
1	1	0	112																																			
1	1	1	128																																			

**Table 154 - HDLC Control Register 3 (Page B & C, Address 1DH)**

Bit	Name	Functional Description			
7	---	Unused.			
6-4	RFFS2-0	These bits select the RXFF (Rx FIFO Full) interrupt threshold level:			
		RFF S2	RFF S1	RFF S0	RX FIFO Full Interrupt threshold Level.
		0	0	0	64
		0	0	1	72
		0	1	0	80
		0	1	1	88
		1	0	0	96
		1	0	1	104
		1	1	0	112
1	1	1	120		
3	---	Unused.			
2-0	TFLS2-0	These bits select the TXFL (Tx FIFO Low) interrupt threshold level:			
		TFL S2	TFL S1	TFL S0	TX FIFO Low Interrupt threshold Level.
		0	0	0	8
		0	0	1	16
		0	1	0	24
		0	1	1	32
		1	0	0	40
		1	0	1	48
		1	1	0	56
1	1	1	64		

**Table 155 - HDLC Control Register 4  
(Page B & C, Address 1EH)**

**Absolute Maximum Ratings\*** - Voltages are with respect to ground ( $V_{SS}$ ) unless otherwise stated.

	Parameter	Symbol	Min	Max	Units
1	Supply Voltage	$V_{DD}$	-0.3	7	V
2	Voltage at Digital Inputs	$V_I$	-0.3	$V_{DD} + 0.3$	V
3	Current at Digital Inputs	$I_I$		30	mA
4	Voltage at Digital Outputs	$V_O$	-0.3	$V_{DD} + 0.3$	V
5	Current at Digital Outputs	$I_O$		30	mA
6	Storage Temperature	$T_{ST}$	-65	150	°C

\* Exceeding these values may cause permanent damage. Functional operation under these conditions is not implied.

**Recommended Operating Conditions** - Voltages are with respect to ground ( $V_{SS}$ ) unless otherwise stated.

	Characteristics	Sym	Min	Typ <sup>‡</sup>	Max	Units	Test Conditions
1	Operating Temperature	$T_{OP}$	-40		85	°C	
2	Supply Voltage	$V_{DD}$	4.75	5	5.25	V	

‡ Typical figures are at 25°C and are for design aid only: not guaranteed and not subject to production testing.

**DC Electrical Characteristics<sup>†</sup>** - Voltages are with respect to ground ( $V_{SS}$ ) unless otherwise stated.

	Characteristics	Sym	Min	Typ <sup>‡</sup>	Max	Units	Test Conditions
1	Supply Current	$I_{DD}$			200	mA	Outputs unloaded. Transmitting an all 1's signal.
2	Input High Voltage (Digital Inputs)	$V_{IH}$	2.0		$V_{DD}$	V	
3	Input Low Voltage (Digital Inputs)	$V_{IL}$	0		0.8	V	
4	Input Leakage (Digital Inputs)	$I_{IL}$			10*	μA	$V_I = 0$ to $V_{DD}$
5	Output High Voltage (Digital Outputs)	$V_{OH}$	2.4		$V_{DD}$	V	$I_{OH}=7$ mA @ $V_{OH}=2.4$ V
6	Output High Current (Digital Outputs)	$I_{OH}$	7			mA	Source $V_{OH}=2.4$ V
7	Output Low Voltage (Digital Outputs)	$V_{OL}$	$V_{SS}$		0.4	V	$I_{OL}=2$ mA @ $V_{OL}=0.4$ V
8	Output Low Current (Digital Outputs)	$I_{OL}$	7			mA	Sink $V_{OL}=0.4$ V
9	High Impedance Leakage (Digital I/O)	$I_{OZ}$			10	μA	$V_O = 0$ to $V_{DD}$

† Characteristics are for clocked operation over the ranges of recommended operating temperature and supply voltage.

‡ Typical figures are at 25°C and are for design aid only: not guaranteed and not subject to production testing.

\* 50 μA for inputs of boundary scan test port:  $T_{di}$ ,  $T_{ms}$ ,  $T_{clk}$  and  $T_{rst}$ .

**AC Electrical Characteristics -Timing Parameter Measurement Voltage Levels**

	Characteristics	Sym	Level	Units	Conditions/Notes
1	TTL Threshold Voltage	$V_{TT}$	1.5 $0.3 \cdot V_{DD}$	V	See Note 1
2	CMOS Threshold Voltage	$V_{CT}$	$0.5 \cdot V_{DD}$	V	See Note 1
3	Rise/Fall Threshold Voltage High	$V_{HM}$	2.0 $0.7 \cdot V_{DD}$	V V	TTL CMOS
4	Rise/Fall Threshold Voltage Low	$V_{LM}$	0.8 $0.3 \cdot V_{DD}$	V V	TTL CMOS

Note 1: Timing for output signals is based on the worst case result of the combination of TTL and CMOS thresholds.

**AC Electrical Characteristics<sup>†</sup> - Motorola Microprocessor Timing**

	Characteristics	Sym	Min	Typ <sup>‡</sup>	Max	Units	Test Conditions
1	DS low	$t_{DSL}$	70			ns	
2	DS High	$t_{DSH}$	60			ns	
3	$\overline{CS}$ Setup	$t_{CSS}$	0			ns	
4	$R/\overline{W}$ Setup	$t_{RWS}$	10			ns	
5	Address Setup	$t_{ADS}$	10			ns	
6	$\overline{CS}$ Hold	$t_{CSH}$	0			ns	
7	$R/\overline{W}$ Hold	$t_{RWH}$	15			ns	
8	Address Hold	$t_{ADH}$	15			ns	
9	Data Delay Read	$t_{DDR}$	90			ns	$C_L=150pF$
10	Data Hold Read	$t_{DHR}$	90			ns	$C_L=150pF$
11	Data Active to High Z Delay	$t_{DAZ}$	90			ns	
12	Data Setup Write	$t_{DSW}$	15			ns	
13	Data Hold Write	$t_{DHW}$	15			ns	

<sup>†</sup> Characteristics are for clocked operation over the ranges of recommended operating temperature and supply voltage.

<sup>‡</sup> Typical figures are at 25°C and are for design aid only: not guaranteed and not subject to production testing.

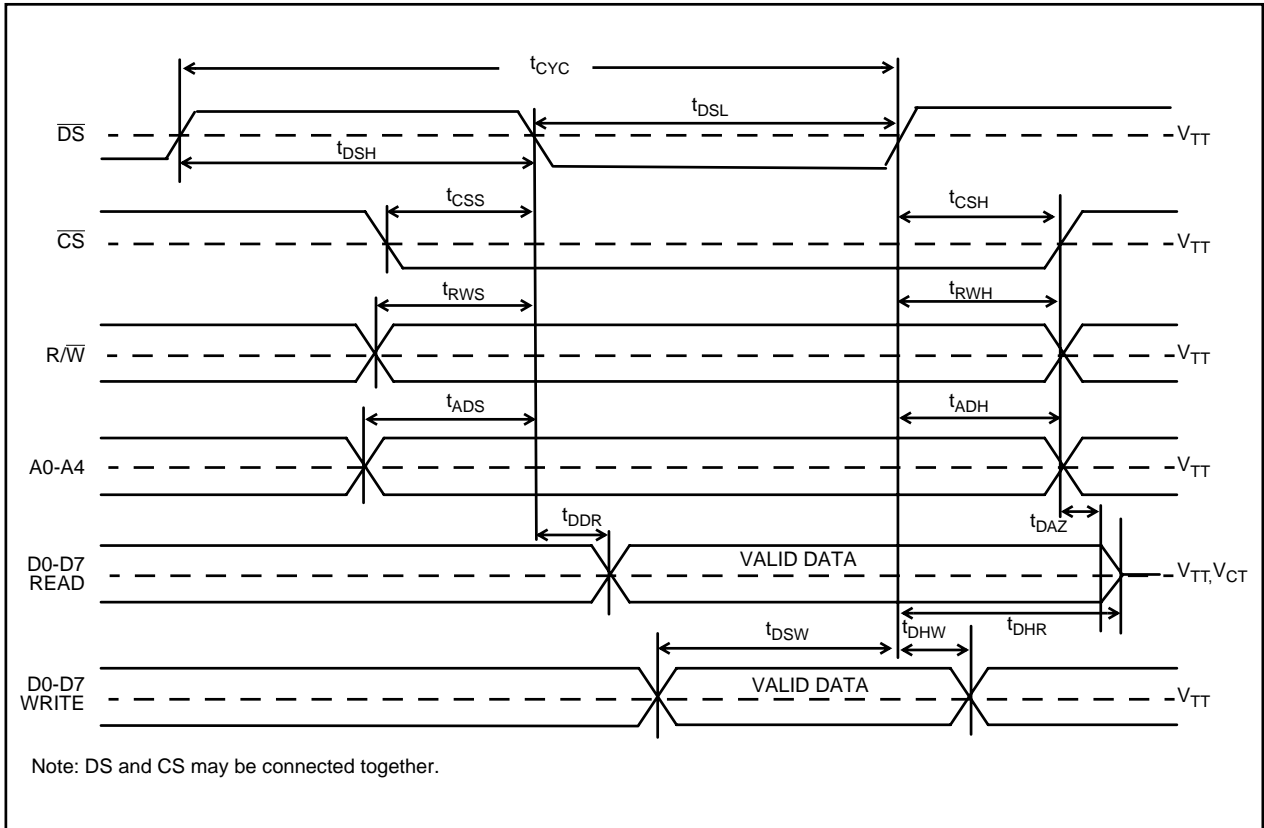

Figure 16 - Motorola Microport Timing

AC Electrical Characteristics<sup>†</sup> - Intel Microprocessor Timing

	Characteristics	Sym	Min	Typ <sup>‡</sup>	Max	Units	Test Conditions
1	RD low	$t_{RD L}$	70			ns	
2	RD High	$t_{RD H}$	60			ns	
3	$\overline{CS}$ Setup	$t_{CS S}$	0			ns	
4	$\overline{CS}$ Hold	$t_{CS H}$	0			ns	
5	Address Setup	$t_{AD S}$	10			ns	
6	Address Hold	$t_{AD H}$	15			ns	
7	Data Delay Read	$t_{DD R}$	90			ns	$C_L=150pF$
8	Data Active to High Z Delay	$t_{DA Z}$	90			ns	
9	Data Setup Write	$t_{DS W}$	15			ns	
10	Data Hold Write	$t_{DH W}$	15			ns	

<sup>†</sup> Characteristics are for clocked operation over the ranges of recommended operating temperature and supply voltage.

<sup>‡</sup> Typical figures are at 25°C and are for design aid only; not guaranteed and not subject to production testing.



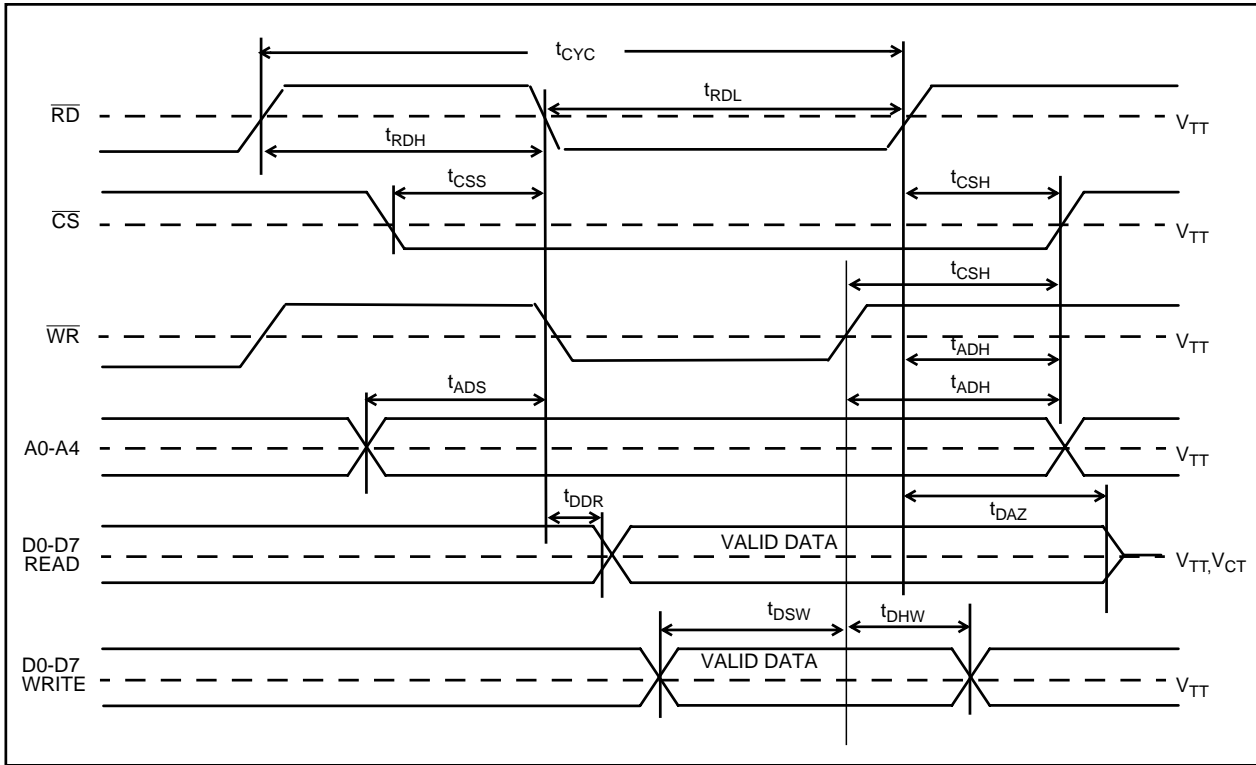

Figure 17 - Intel Microport Timing

AC Electrical Characteristics - Transmit Data Link Timing (T1 mode)

	Characteristic	Sym	Min	Typ	Max	Units	Test Conditions
1	Data Link Clock Pulse Width	$t_{DW}$		324		ns	150pF
2	Data Link Setup	$t_{TDS}$	35			ns	
3	Data Link Hold	$t_{TDH}$	35			ns	

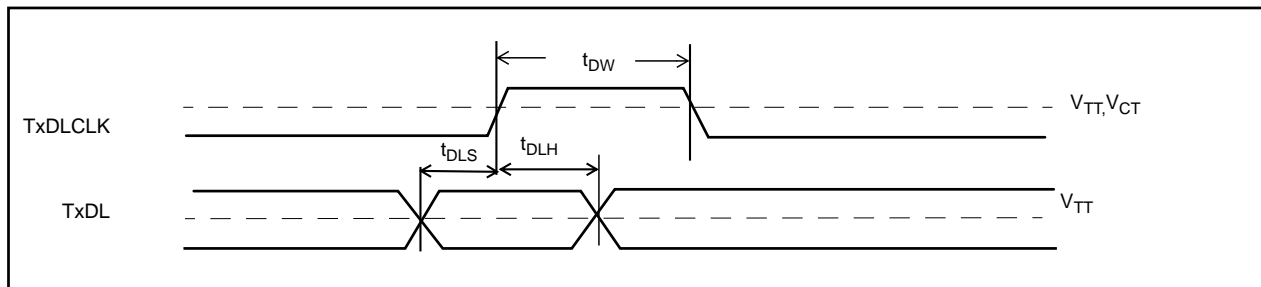
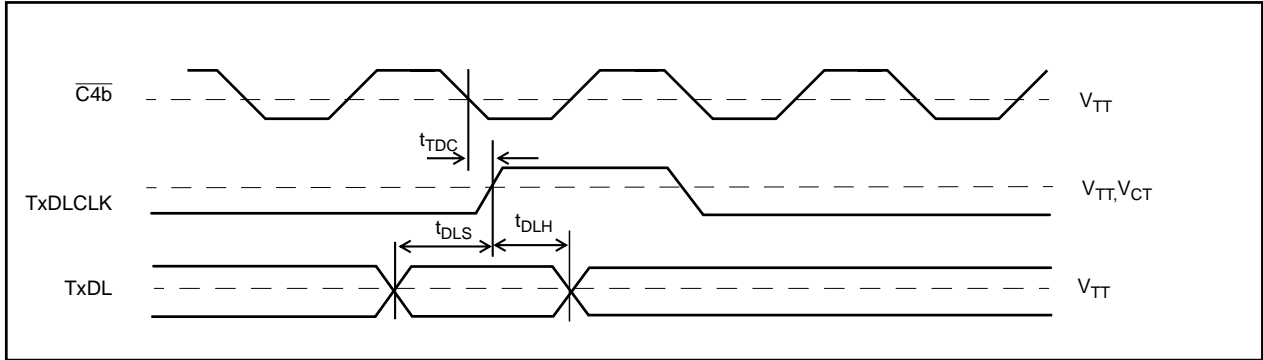

Figure 18 - Transmit Data Link Timing Diagram (T1 mode)

**AC Electrical Characteristics - Transmit Data Link Timing (E1 mode)**

	Characteristic	Sym	Min	Typ	Max	Units	Test Conditions
1	Data Link Clock Output Delay	$t_{TDC}$		244		ns	150pF
2	Data Link Setup	$t_{TDS}$	35			ns	
3	Data Link Hold	$t_{TDH}$	35			ns	



**Figure 19 - Transmit Data Link Timing Diagram (E1 mode)**

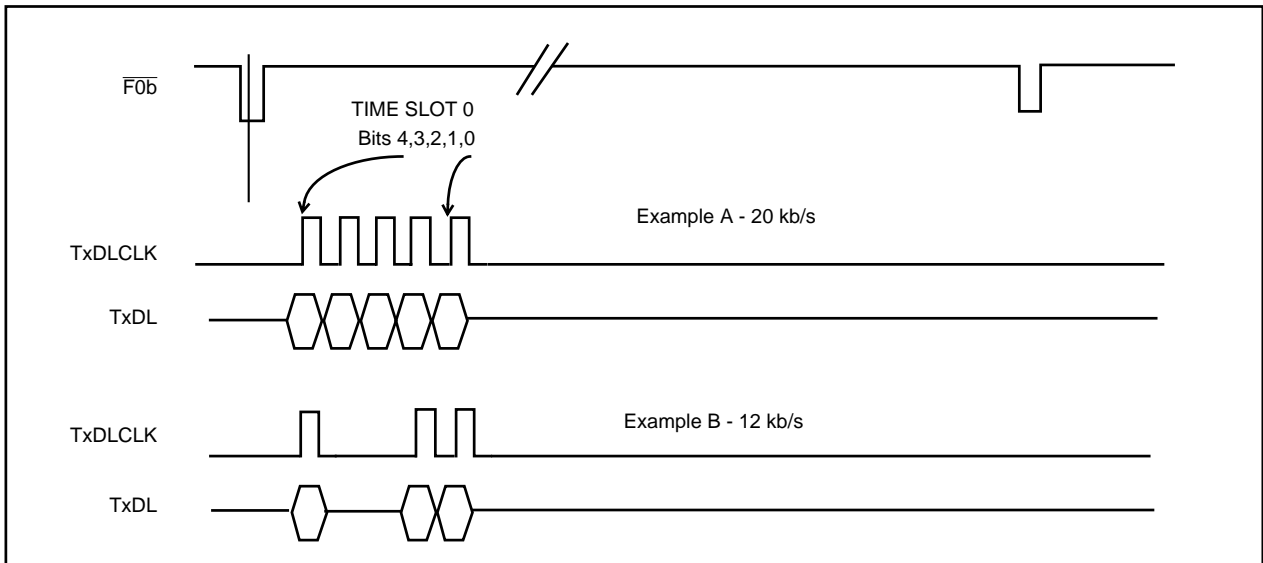

**Figure 20 - Transmit Data Link Functional Timing (E1 mode)**

**AC Electrical Characteristics - Receive Data Link Timing (T1 mode)**

	Characteristic	Sym	Min	Typ	Max	Units	Test Conditions
1	Data Link Clock Output Delay	$t_{RDC}$			160	ns	50pF
2	Data Link Output Delay	$t_{RDD}$			45	ns	50pF
3	RxFP Output Delay	$t_{RFD}$			45	ns	50pF

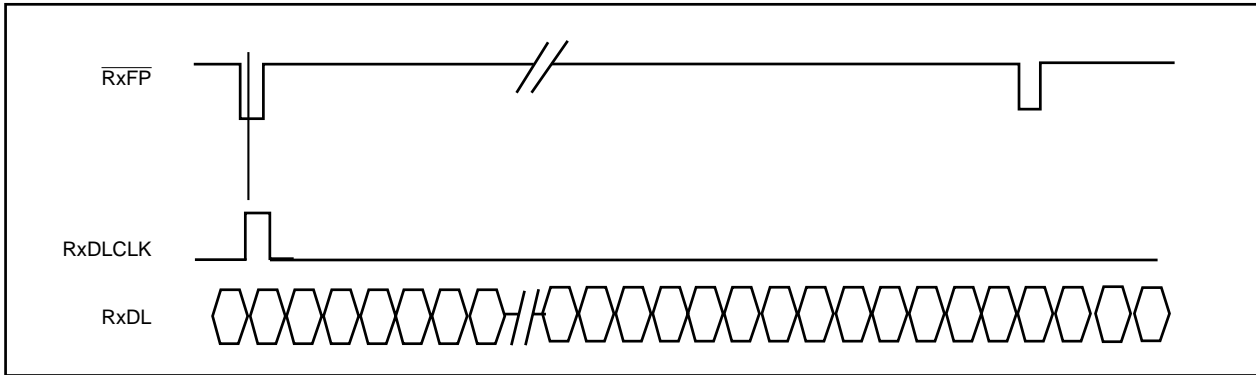

Figure 21 - Receive Data Link Functional Timing (T1 mode)

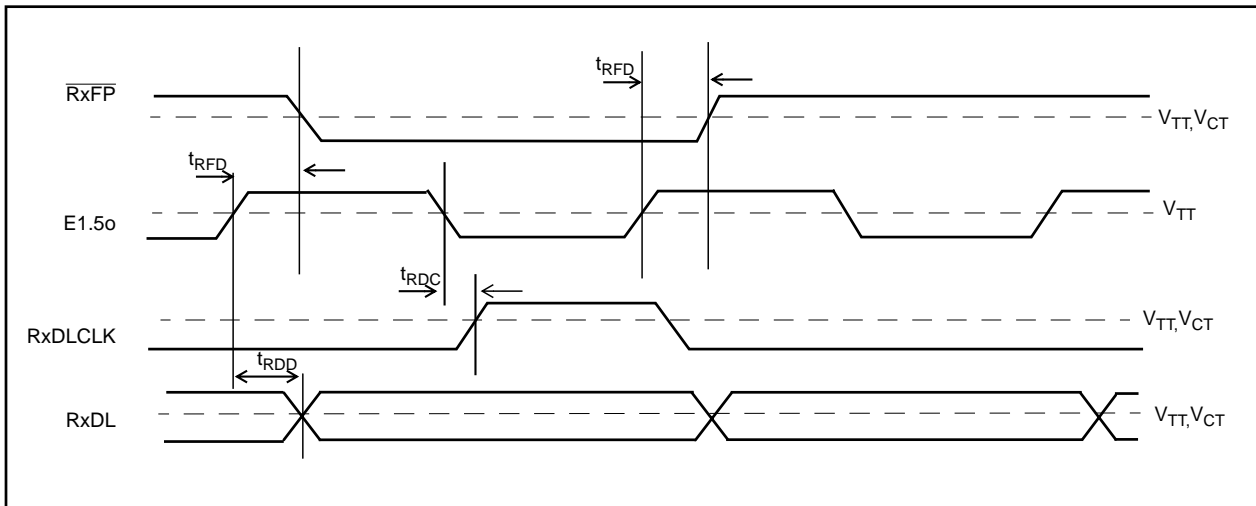

Figure 22 - Receive Data Link Diagram (T1 mode)

AC Electrical Characteristics - Receive Data Link Timing (E1 mode)

	Characteristic	Sym	Min	Typ	Max	Units	Test Conditions
1	Data Link Clock Output Delay	$t_{RDC}$			160	ns	50pF
2	Data Link Output Delay	$t_{RDD}$			45	ns	50pF
3	$\overline{\text{RxFP}}$ Output Delay	$t_{RFD}$			45	ns	50pF

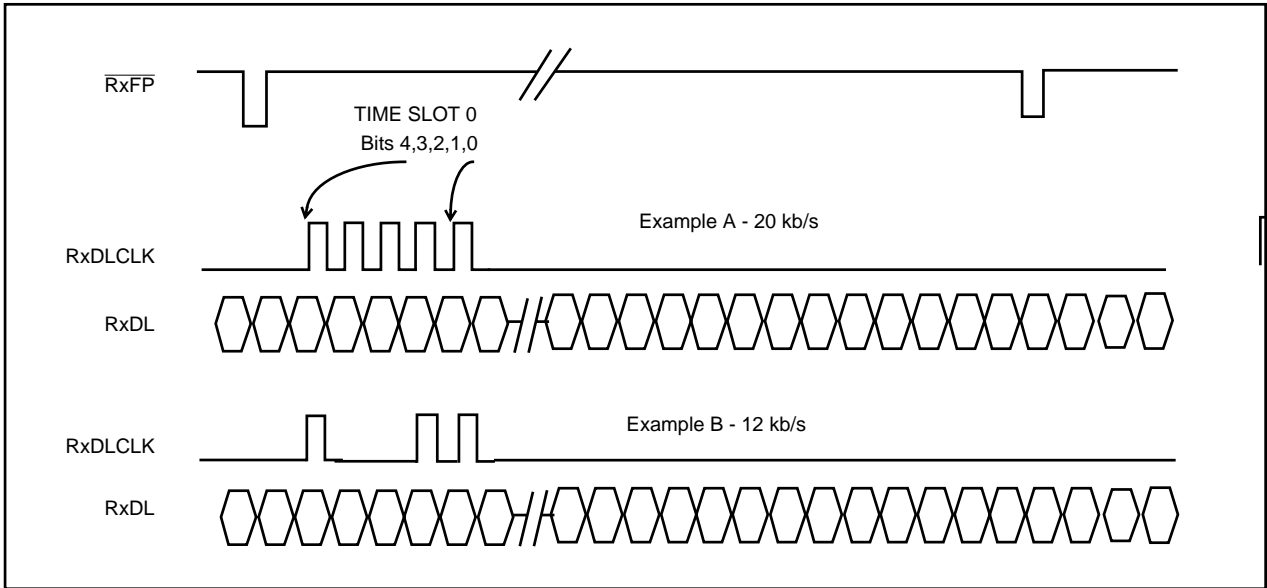

Figure 23 - Receive Data Link Functional Timing (E1 mode)

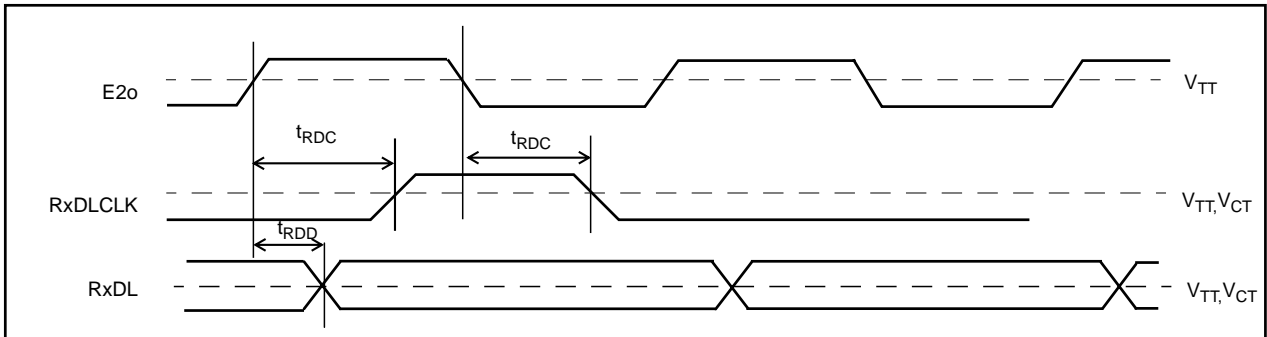

Figure 24 - Receive Data Link Timing Diagram (E1 mode)

AC Electrical Characteristics - ST-BUS (E1 or T1 mode)

	Characteristic	Sym	Min	Typ	Max	Units	Test Conditions
1	$\overline{C4b}$ Clock Width High or Low	$t_{4W}$	80			ns	Line Synchronization Mode
2	Frame Pulse Setup	$t_{FPS}$	10			ns	
3	Frame Pulse Low	$t_{FPL}$	70			ns	
4	Serial Input Setup	$t_{SIS}$	20			ns	
5	Serial Input Hold	$t_{SIH}$	20			ns	
6	Serial Output Delay	$t_{SOD}$			75	ns	150pF
7	Frame Pulse Delay	$t_{FDP}$	40			ns	Line Synchronous Mode

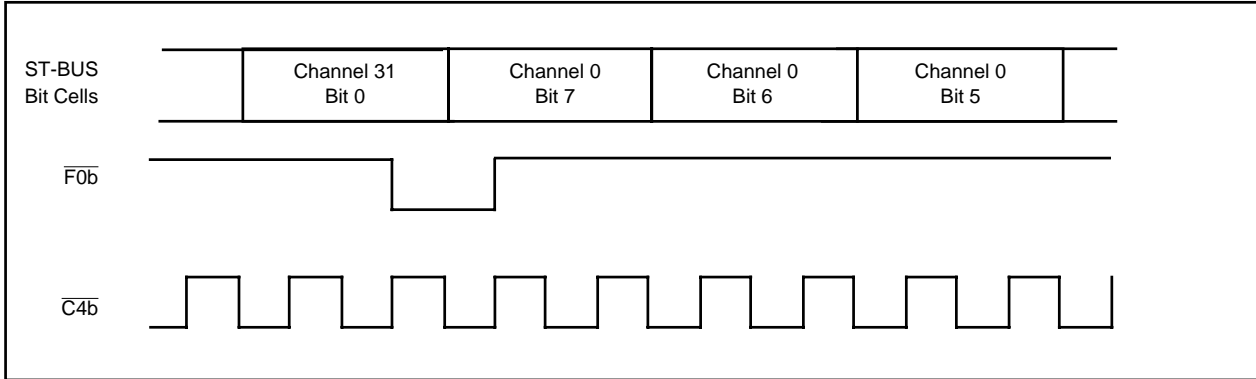

Figure 25 - ST-BUS Functional Timing Diagram

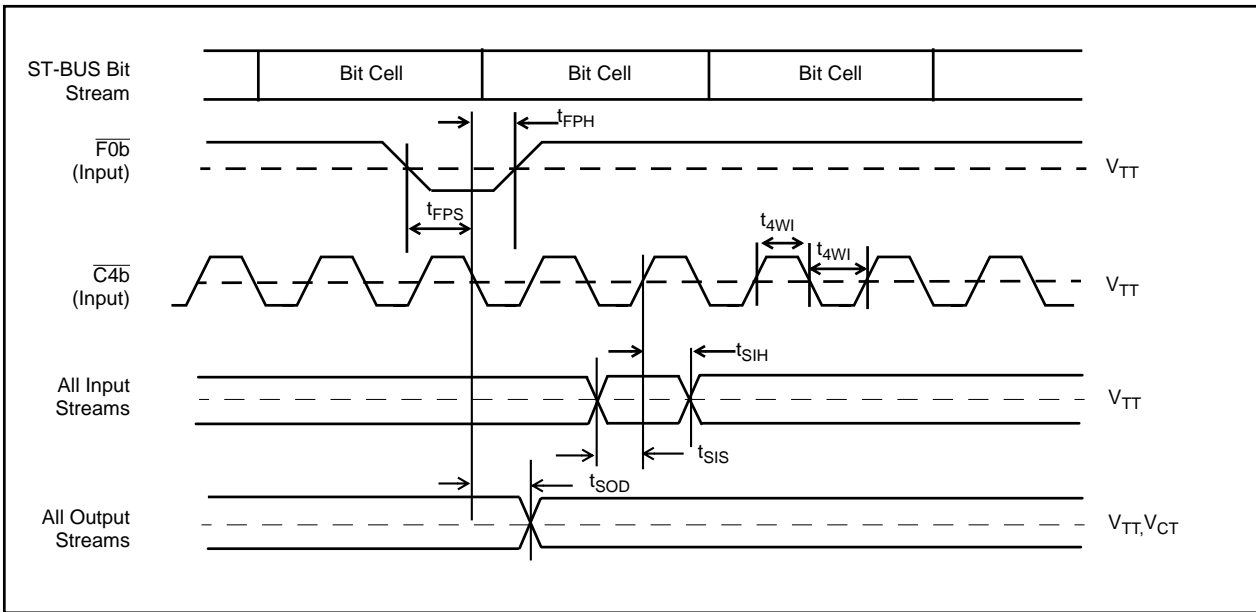

Figure 26 - ST-BUS Timing Diagram (Input Clocks)

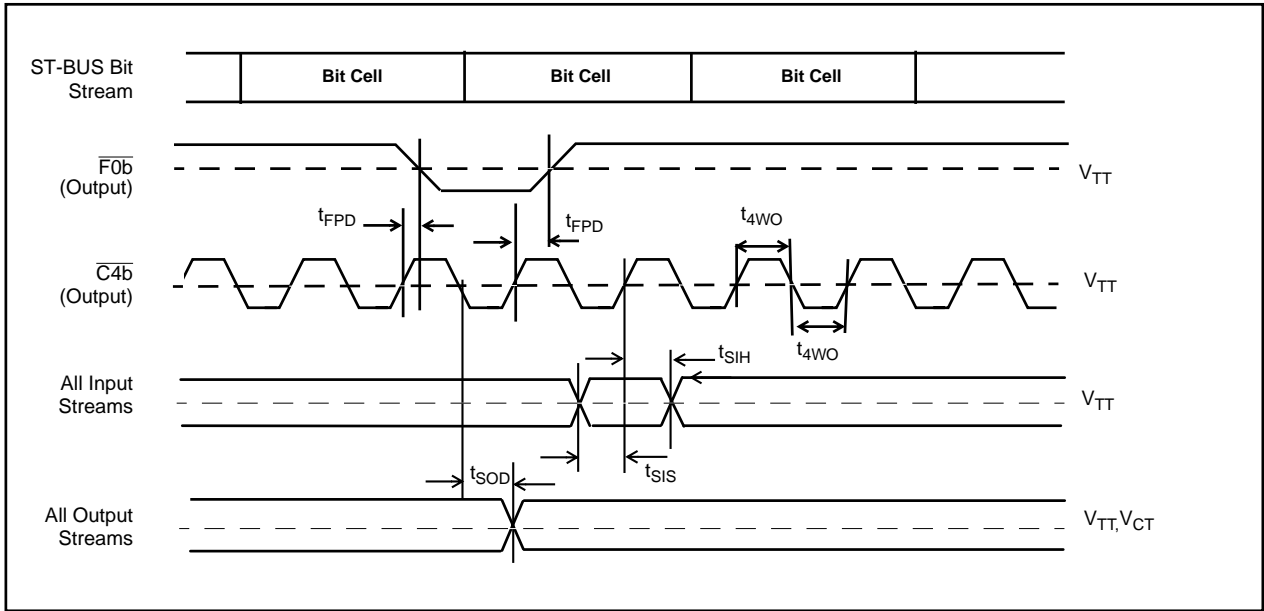

Figure 27 - ST-BUS Timing Diagram (Output Clocks)

AC Electrical Characteristics - Multiframe Timing (T1 or E1 mode)

	Characteristic	Sym	Min	Typ	Max	Units	Test Conditions
1	Receive Multiframe Output Delay	$t_{MOD}$			50	ns	150pF
2	Transmit Multiframe Setup	$t_{MS}$	50			ns	
3	Transmit Multiframe Hold	$t_{MH}$	50		*	ns	* 256 C2 periods -100nsec

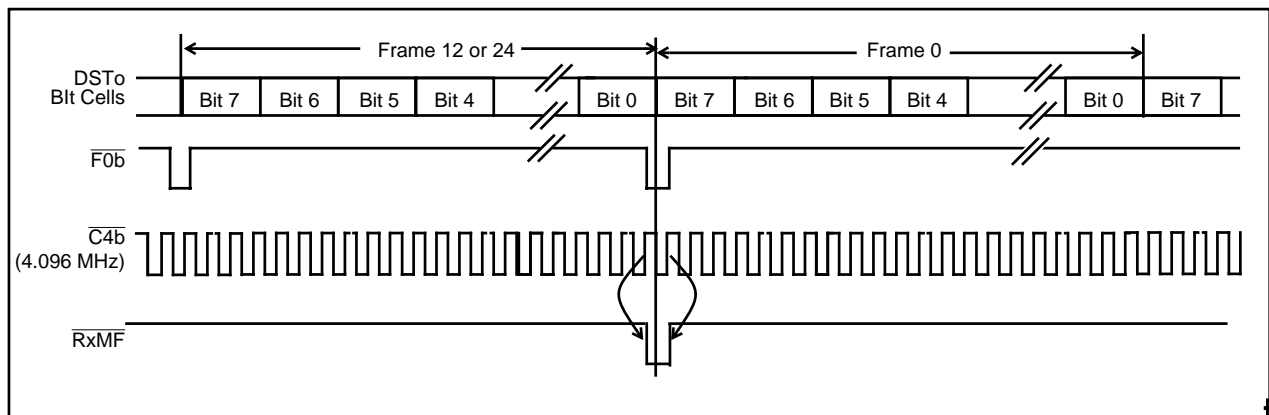

Figure 28 - Receive Multiframe Functional Timing (E1 mode)

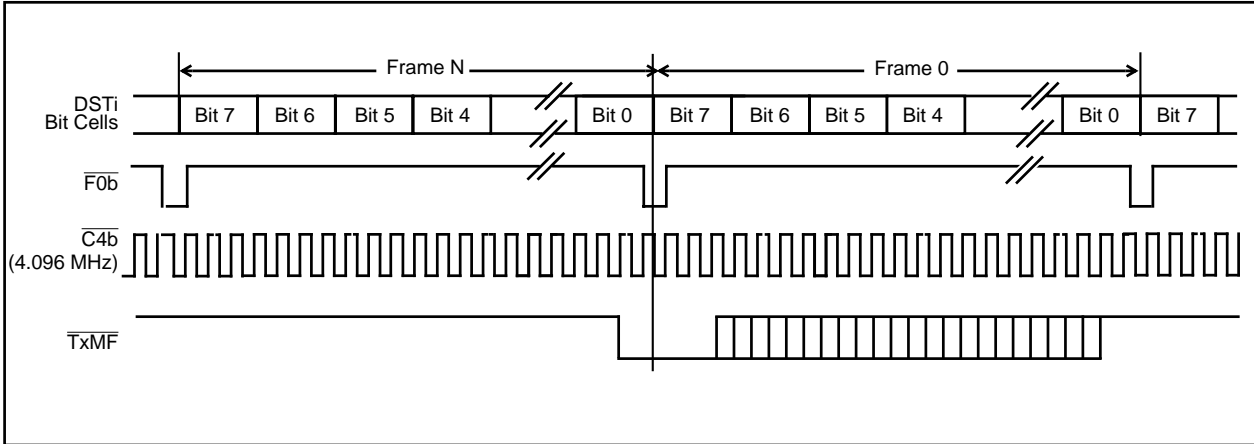

Figure 29 - Transmit Multiframe Functional Timing (T1 mode or E1 mode)

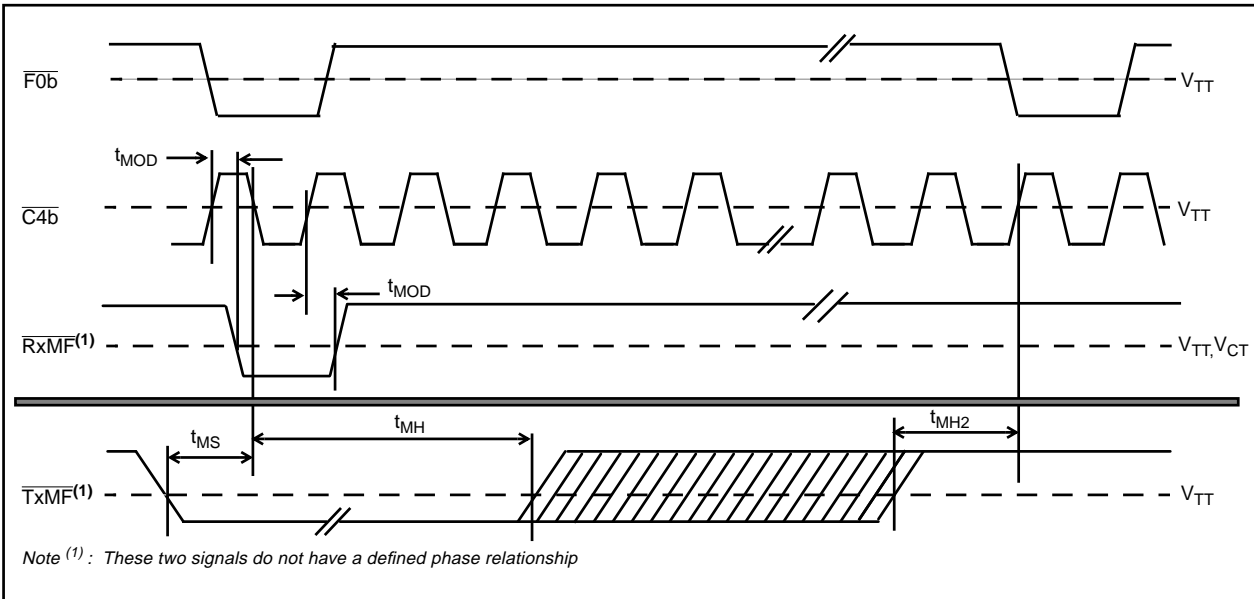

Figure 30 - Multiframe Timing Diagram (T1 mode or E1 mode)



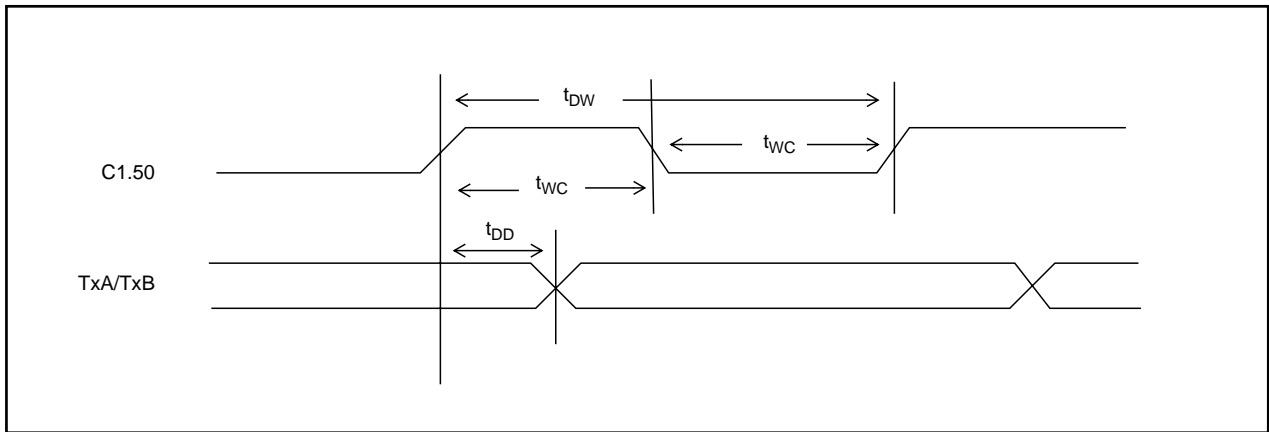

Figure 31 - Transmit Digital Data Timing Diagram (LIU Disabled)

**AC Electrical Characteristics - Transmit Digital Framing Mode**

	Characteristics	Sym	Min	Typ	Max	Units	Test Conditions
1	Transmit Clock Pulse Width	$t_{DW}$		648		ns	150pF - T1 mode
2	Transmit clock Pulse Width	$t_{DW}$		244		ns	150pF - E1 mode
3	Transmit Data Delay	$t_{DD}$			25	ns	

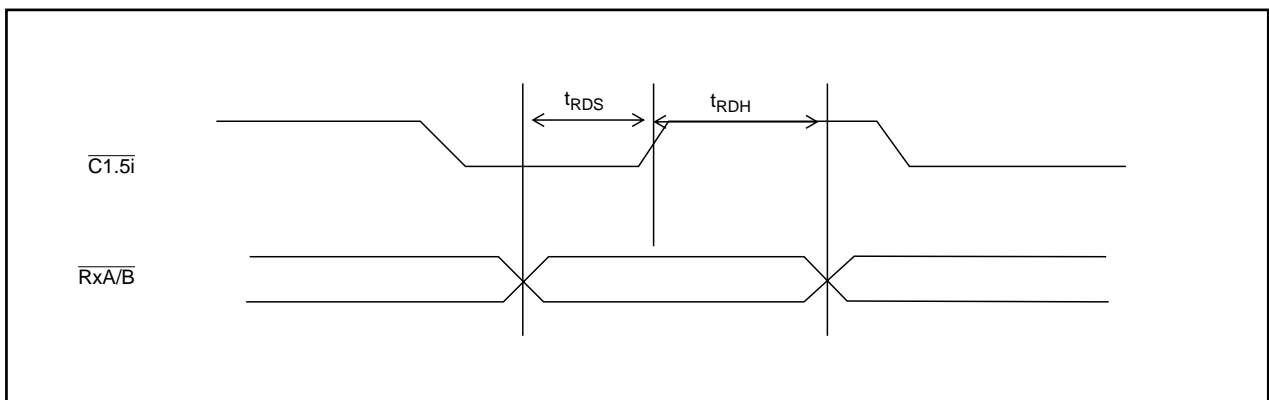

Figure 32 - Receive Digital Data Timing Diagram (LIU Disabled)

**AC Electrical Characteristics - Receive Digital Framing Mode**

	Characteristics	Sym	Min	Typ	Max	Units	Test Conditions
1	Receive Data Setup Time	$t_{RDS}$	15			ns	
2	Receive Data Hold Time	$t_{RDH}$	15			ns	

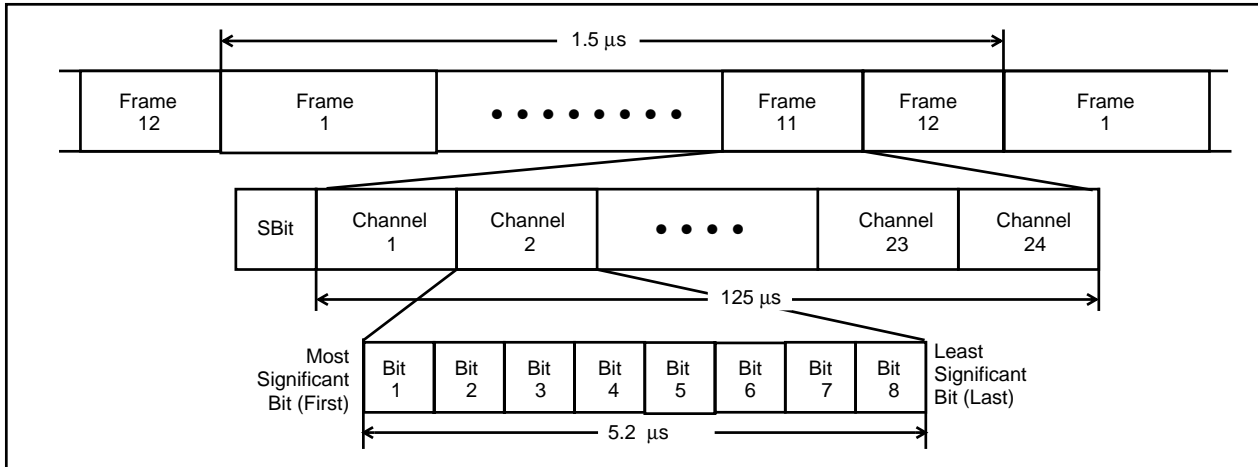

Figure 33 - D4 Format

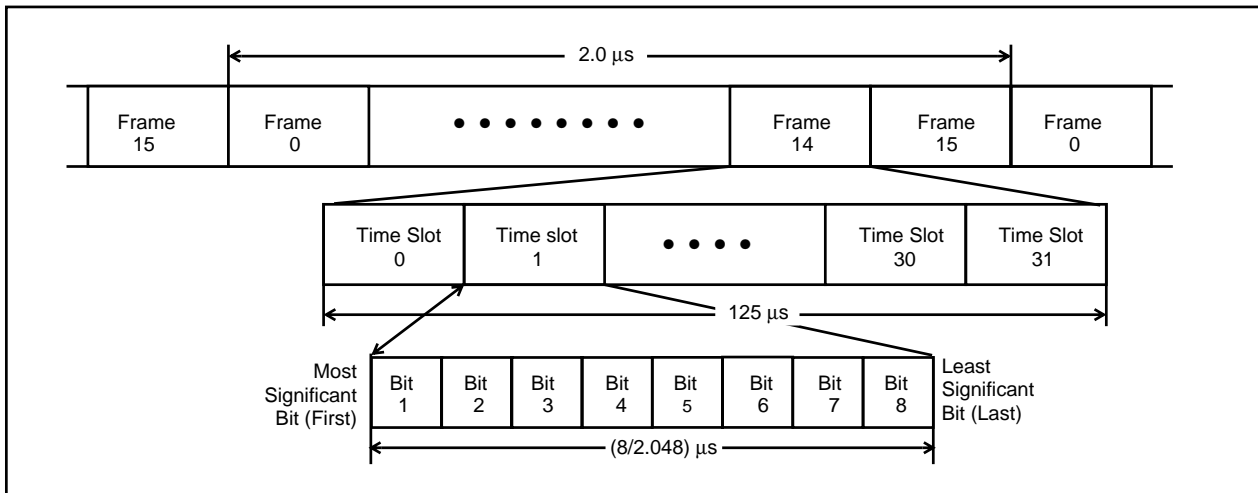

Figure 34 - PCM 30 Format

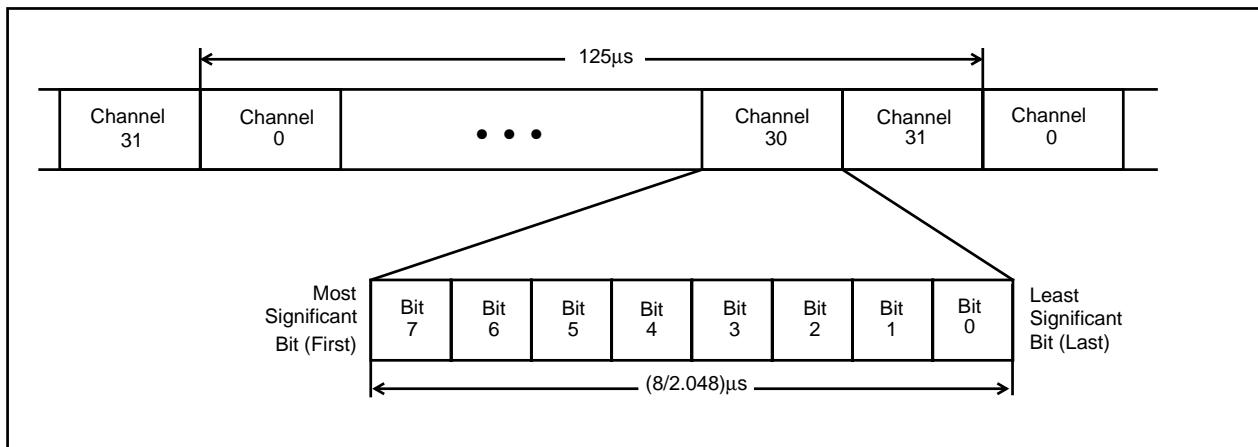
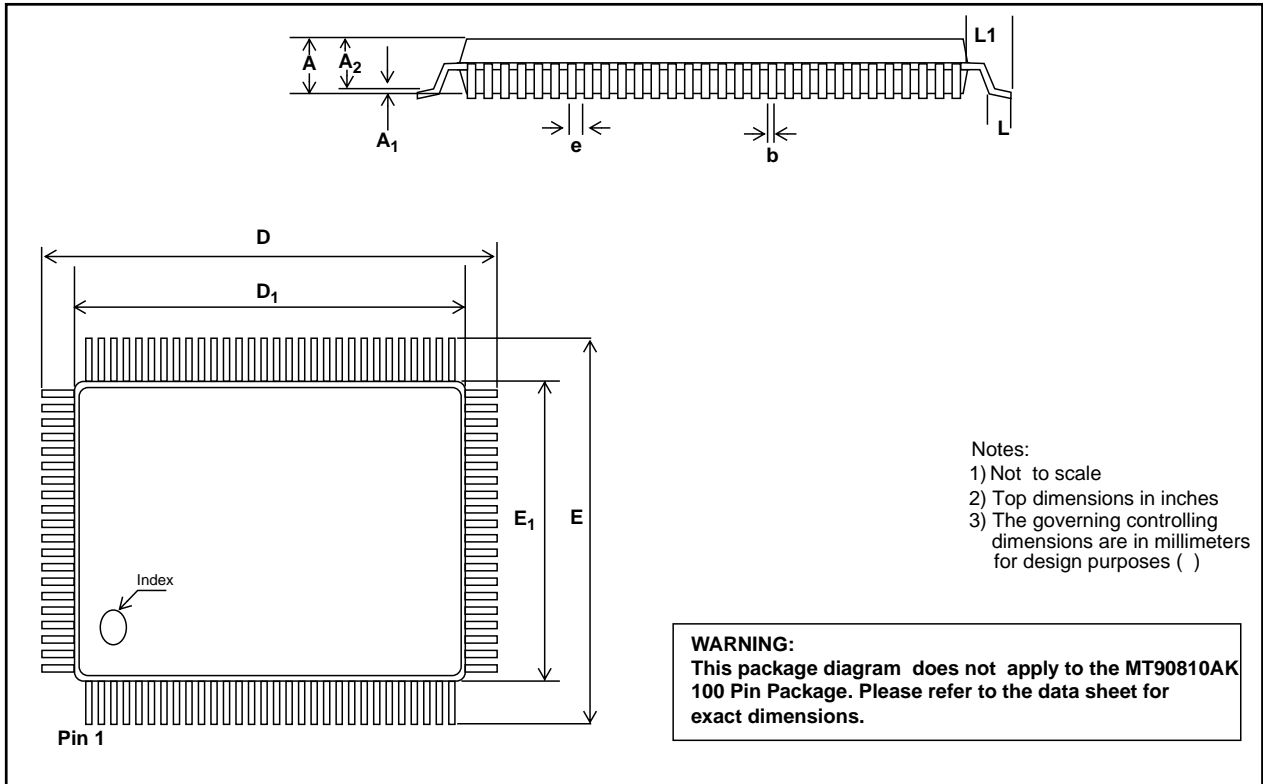

Figure 35 - ST-BUS Stream Format

# Package Outlines



**Metric Quad Flat Pack - L Suffix**

Dim	44-Pin		64-Pin		100-Pin		128-Pin	
	Min	Max	Min	Max	Min	Max	Min	Max
<b>A</b>	-	0.096 (2.45)	-	0.134 (3.40)	-	0.134 (3.40)	-	0.154 (3.85)
<b>A1</b>	0.01 (0.25)	-	0.01 (0.25)	-	0.01 (0.25)	-	0.00	0.01 (0.25)
<b>A2</b>	0.077 (1.95)	0.083 (2.10)	0.1 (2.55)	0.12 (3.05)	0.1 (2.55)	0.12 (3.05)	0.125 (3.17)	0.144 (3.60)
<b>b</b>	0.01 (0.30)	0.018 (0.45)	0.013 (0.35)	0.02 (0.50)	0.009 (0.22)	0.015 (0.38)	0.019 (0.30)	0.018 (0.45)
<b>D</b>	0.547 BSC (13.90 BSC)		0.941 BSC (23.90 BSC)		0.941 BSC (23.90 BSC)		1.23 BSC (31.2 BSC)	
<b>D<sub>1</sub></b>	0.394 BSC (10.00 BSC)		0.787 BSC (20.00 BSC)		0.787 BSC (20.00 BSC)		1.102 BSC (28.00 BSC)	
<b>E</b>	0.547 BSC (13.90 BSC)		0.705 BSC (17.90 BSC)		0.705 BSC (17.90 BSC)		1.23 BSC (31.2 BSC)	
<b>E<sub>1</sub></b>	0.394 BSC (10.00 BSC)		0.551 BSC (14.00 BSC)		0.551 BSC (14.00 BSC)		1.102 BSC (28.00 BSC)	
<b>e</b>	0.031 BSC (0.80 BSC)		0.039 BSC (1.0 BSC)		0.256 BSC (6.65 BSC)		0.031 BSC (0.80 BSC)	
<b>L</b>	0.029 (0.73)	0.04 (1.03)	0.029 (0.73)	0.04 (1.03)	0.029 (0.73)	0.04 (1.03)	0.029 (0.73)	0.04 (1.03)
<b>L1</b>	0.077 REF (1.95 REF)		0.077 REF (1.95 REF)		0.077 REF (1.95 REF)		0.063 REF (1.60 REF)	

**NOTE:** Governing controlling dimensions in parenthesis ( ) are in millimeters.

# Package Outlines

Dim	160-Pin		208-Pin		240-Pin	
	Min	Max	Min	Max	Min	Max
A	-	0.154 (3.92)		.161 (4.10)	-	0.161 (4.10)
A1		0.01 (0.25)	0.01 (0.25)	0.02 (0.50)	0.01 (0.25)	0.02 (0.50)
A2	0.125 (3.17)	0.144 (3.67)	.126 (3.20)	.142 (3.60)	0.126 (3.2)	0.142 (3.60)
b	0.009 (0.22)	0.015 (0.38)	.007 (0.17)	.011 (0.27)	0.007 (0.17)	0.010 (0.27)
D	1.23 BSC (31.2 BSC)		1.204 (30.6)		1.360 BSC (34.6 BSC)	
D <sub>1</sub>	1.102 BSC (28.00 BSC)		1.102 (28.00)		1.26 BSC (32.00 BSC)	
E	1.23 BSC (31.2 BSC)		1.204 BSC (30.6 BSC)		1.360 BSC (34.6 BSC)	
E <sub>1</sub>	1.102 BSC (28.00 BSC)		1.102 BSC (28.00 BSC)		1.26 BSC (32.00 BSC)	
e	0.025 BSC (0.65 BSC)		0.020 BSC (0.50 BSC)		0.0197 BSC (0.50 BSC)	
L	0.029 (0.73)	0.04 (1.03)	0.018 (0.45)	0.029 (0.75)	0.018 (0.45)	0.029 (0.75)
L1	0.063 REF (1.60 REF)		0.051 REF (1.30 REF)		0.051 REF (1.30 REF)	

NOTE: Governing controlling dimensions in parenthesis ( ) are in millimeters.

# Package Outlines

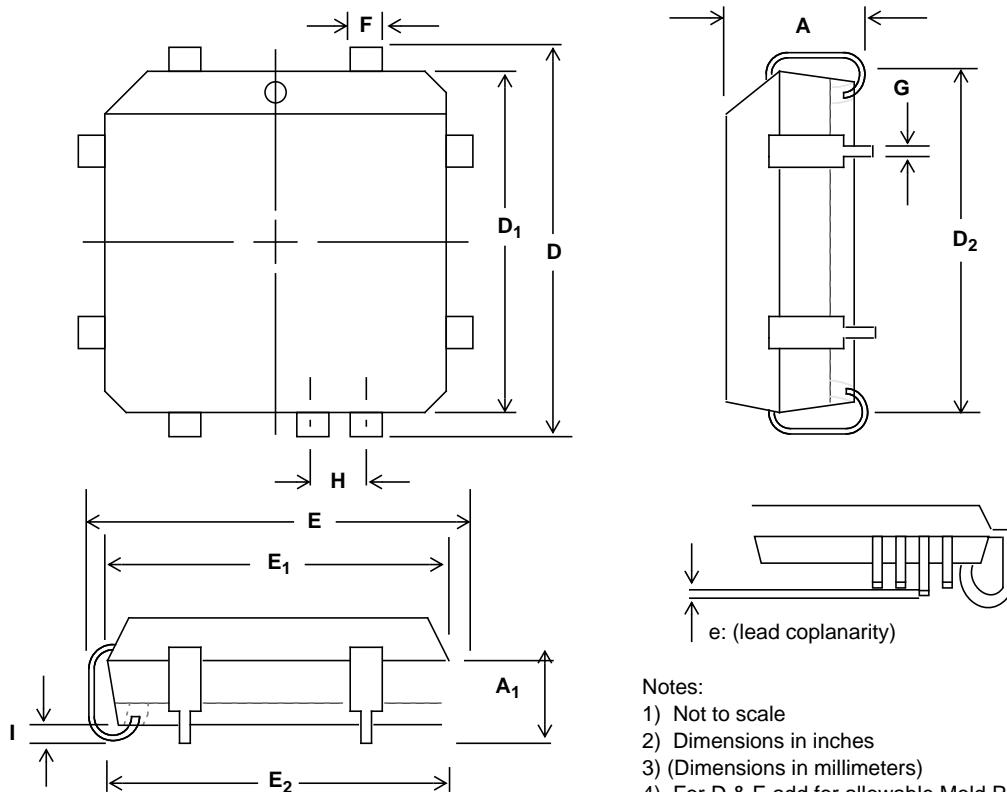

- Notes:
- 1) Not to scale
  - 2) Dimensions in inches
  - 3) (Dimensions in millimeters)
  - 4) For D & E add for allowable Mold Protrusion 0.010"

Dim	20-Pin		28-Pin		44-Pin		68-Pin		84-Pin	
	Min	Max	Min	Max	Min	Max	Min	Max	Min	Max
<b>A</b>	0.165 (4.20)	0.180 (4.57)	0.165 (4.20)	0.180 (4.57)	0.165 (4.20)	0.180 (4.57)	0.165 (4.20)	0.200 (5.08)	0.165 (4.20)	0.200 (5.08)
<b>A<sub>1</sub></b>	0.090 (2.29)	0.120 (3.04)	0.090 (2.29)	0.120 (3.04)	0.090 (2.29)	0.120 (3.04)	0.090 (2.29)	0.130 (3.30)	0.090 (2.29)	0.130 (3.30)
<b>D/E</b>	0.385 (9.78)	0.395 (10.03)	0.485 (12.32)	0.495 (12.57)	0.685 (17.40)	0.695 (17.65)	0.985 (25.02)	0.995 (25.27)	1.185 (30.10)	1.195 (30.35)
<b>D<sub>1</sub>/E<sub>1</sub></b>	0.350 (8.890)	0.356 (9.042)	0.450 (11.430)	0.456 (11.582)	0.650 (16.510)	0.656 (16.662)	0.950 (24.130)	0.958 (24.333)	1.150 (29.210)	1.158 (29.413)
<b>D<sub>2</sub>/E<sub>2</sub></b>	0.290 (7.37)	0.330 (8.38)	0.390 (9.91)	0.430 (10.92)	0.590 (14.99)	0.630 (16.00)	0.890 (22.61)	0.930 (23.62)	1.090 (27.69)	1.130 (28.70)
<b>e</b>	0	0.004	0	0.004	0	0.004	0	0.004	0	0.004
<b>F</b>	0.026 (0.661)	0.032 (0.812)	0.026 (0.661)	0.032 (0.812)	0.026 (0.661)	0.032 (0.812)	0.026 (0.661)	0.032 (0.812)	0.026 (0.661)	0.032 (0.812)
<b>G</b>	0.013 (0.331)	0.021 (0.533)	0.013 (0.331)	0.021 (0.533)	0.013 (0.331)	0.021 (0.533)	0.013 (0.331)	0.021 (0.533)	0.013 (0.331)	0.021 (0.533)
<b>H</b>	0.050 BSC (1.27 BSC)		0.050 BSC (1.27 BSC)		0.050 BSC (1.27 BSC)		0.050 BSC (1.27 BSC)		0.050 BSC (1.27 BSC)	
<b>I</b>	0.020 (0.51)		0.020 (0.51)		0.020 (0.51)		0.020 (0.51)		0.020 (0.51)	

Plastic J-Lead Chip Carrier - P-Suffix



<http://www.mitelsemi.com>

**World Headquarters - Canada**

Tel: +1 (613) 592 2122  
Fax: +1 (613) 592 6909

**North America**

Tel: +1 (770) 486 0194  
Fax: +1 (770) 631 8213

**Asia/Pacific**

Tel: +65 333 6193  
Fax: +65 333 6192

**Europe, Middle East,  
and Africa (EMEA)**

Tel: +44 (0) 1793 518528  
Fax: +44 (0) 1793 518581

Information relating to products and services furnished herein by Mitel Corporation or its subsidiaries (collectively "Mitel") is believed to be reliable. However, Mitel assumes no liability for errors that may appear in this publication, or for liability otherwise arising from the application or use of any such information, product or service or for any infringement of patents or other intellectual property rights owned by third parties which may result from such application or use. Neither the supply of such information or purchase of product or service conveys any license, either express or implied, under patents or other intellectual property rights owned by Mitel or licensed from third parties by Mitel, whatsoever. Purchasers of products are also hereby notified that the use of product in certain ways or in combination with Mitel, or non-Mitel furnished goods or services may infringe patents or other intellectual property rights owned by Mitel.

This publication is issued to provide information only and (unless agreed by Mitel in writing) may not be used, applied or reproduced for any purpose nor form part of any order or contract nor to be regarded as a representation relating to the products or services concerned. The products, their specifications, services and other information appearing in this publication are subject to change by Mitel without notice. No warranty or guarantee express or implied is made regarding the capability, performance or suitability of any product or service. Information concerning possible methods of use is provided as a guide only and does not constitute any guarantee that such methods of use will be satisfactory in a specific piece of equipment. It is the user's responsibility to fully determine the performance and suitability of any equipment using such information and to ensure that any publication or data used is up to date and has not been superseded. Manufacturing does not necessarily include testing of all functions or parameters. These products are not suitable for use in any medical products whose failure to perform may result in significant injury or death to the user. All products and materials are sold and services provided subject to Mitel's conditions of sale which are available on request.

M Mitel (design) and ST-BUS are registered trademarks of MITEL Corporation  
Mitel Semiconductor is an ISO 9001 Registered Company  
Copyright 1999 MITEL Corporation  
All Rights Reserved  
Printed in CANADA

TECHNICAL DOCUMENTATION - NOT FOR RESALE