

FX316 NMT Audio Filter Array

Publication D/316/4 December 1989

Provisional Issue

Features/Applications

- Cellular Radio Audio Processing
- NMT 450 & 900MHz Base Station and Mobile Specifications
- High Order Lowpass Filter including SAT Rejection
- Low Group Delay Distortion
- 4kHz SAT Recovery Bandpass Filter
- Uncommitted Amplifier
- Switched Capacitor Filters
- Xtal Controlled
- Single 5 Volt CMOS Process
- Chip Enable Powersave Feature
- Few External components
- Surface Mount or DIL Package Style

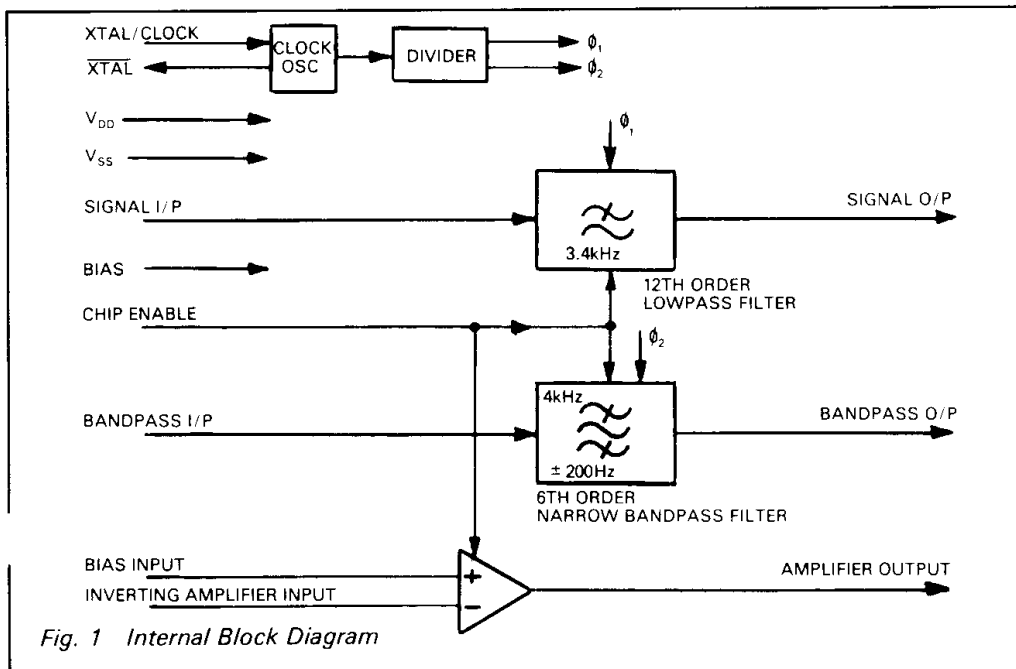

FX316

Brief Description

The FX316 is a low-power CMOS Switched Capacitor filter array designed to meet NMT Base and Mobile specifications.

The device in detail consists of:

(1) a 12th order 3.4kHz lowpass filter with sufficient rejection of 4kHz signals to meet NMT 450 and 900 filter response specifications for both base and mobile equipments. The lowpass filter also provides a low group delay distortion path.

(2) a 6th order 4kHz narrow bandpass filter which meets the NMT 450 and 900 mobile specifications for SAT recovery.

(3) an uncommitted amplifier which may be used for any specific applications such as pre-emphasis, de-emphasis, buffering etc. An on chip oscillator uses a 1MHz Xtal and provides all reference clocks for the switched capacitor filters via a divider chain. Alternatively, an external clock may be used. The chip enable feature is used to disable the three circuit elements thus reducing current consumption.

Pin Number

Function

FX316J	FX316LG	FX316LH	
1	1	1	Xtal/Clock: 1 MHz Xtal I/P or externally derived clock can be injected into this input. Input to on-chip inverting oscillator.
2	2	2	$\overline{\text{Xtal}}$: 1 MHz Xtal O/P. Inverting output of on-chip oscillator.
3	5	7	Chip Enable: Internally pulled to V_{DD} . A logic '0' applied to this input will disable all filters and the uncommitted amplifier (powersave mode).
4	6	8	Signal I/P: Input to lowpass filter. This input is internally biased and externally a.c. coupled by C_2 .
5	7	10	Signal O/P: Lowpass filter output internally biased to $V_{DD}/2$.
6	8	11	V_{SS}: Negative supply.
7	10	13	Bandpass I/P: Input to bandpass filter. This input is internally biased and externally a.c. coupled by C_3 .
8	12	15	V_{SS}: Negative supply.
9	13	16	Bandpass O/P: Bandpass filter output internally biased to $V_{DD}/2$.
10	14	17	Bias: $V_{DD}/2$ Bias Pin. Externally decoupled by C_5 . (<i>See Fig. 2, Note 1</i>).
11	17	20	Amp O/P: Uncommitted amplifier output.
12	18	22	Amp I/P: Uncommitted amplifier inverting input.
13	19	23	Bias I/P: Connect externally to 'Bias' pin.
14	20	24	No Connection: Internally connected leave open circuit.
15	23	27	No Connection: Internally connected leave open circuit.
16	24	28	V_{DD}: Positive supply.
			FX316LG: Pin numbers 3, 4, 9, 11, 15, 16, 21 and 22 are not connected.
			FX316LH Pin numbers 3, 4, 5, 6, 9, 12, 14, 18, 19, 21, 25 and 26 are not connected.
			Note: Output Loading. Large capacitive loads could cause the output pins of this device to oscillate. If capacitive loads in excess of 200pF are unavoidable, a resistor of typically <100 Ω put in series with the load should minimise this effect.

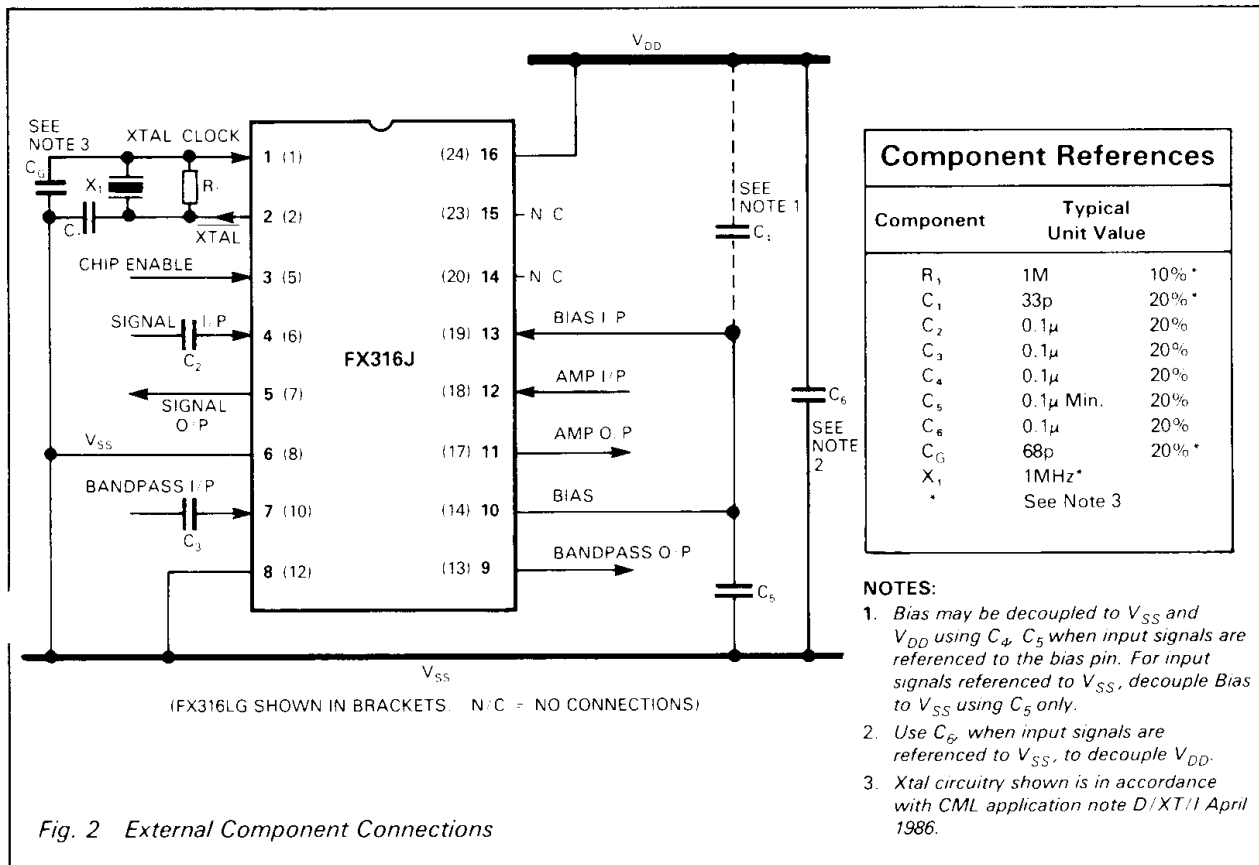

Fig. 2 External Component Connections

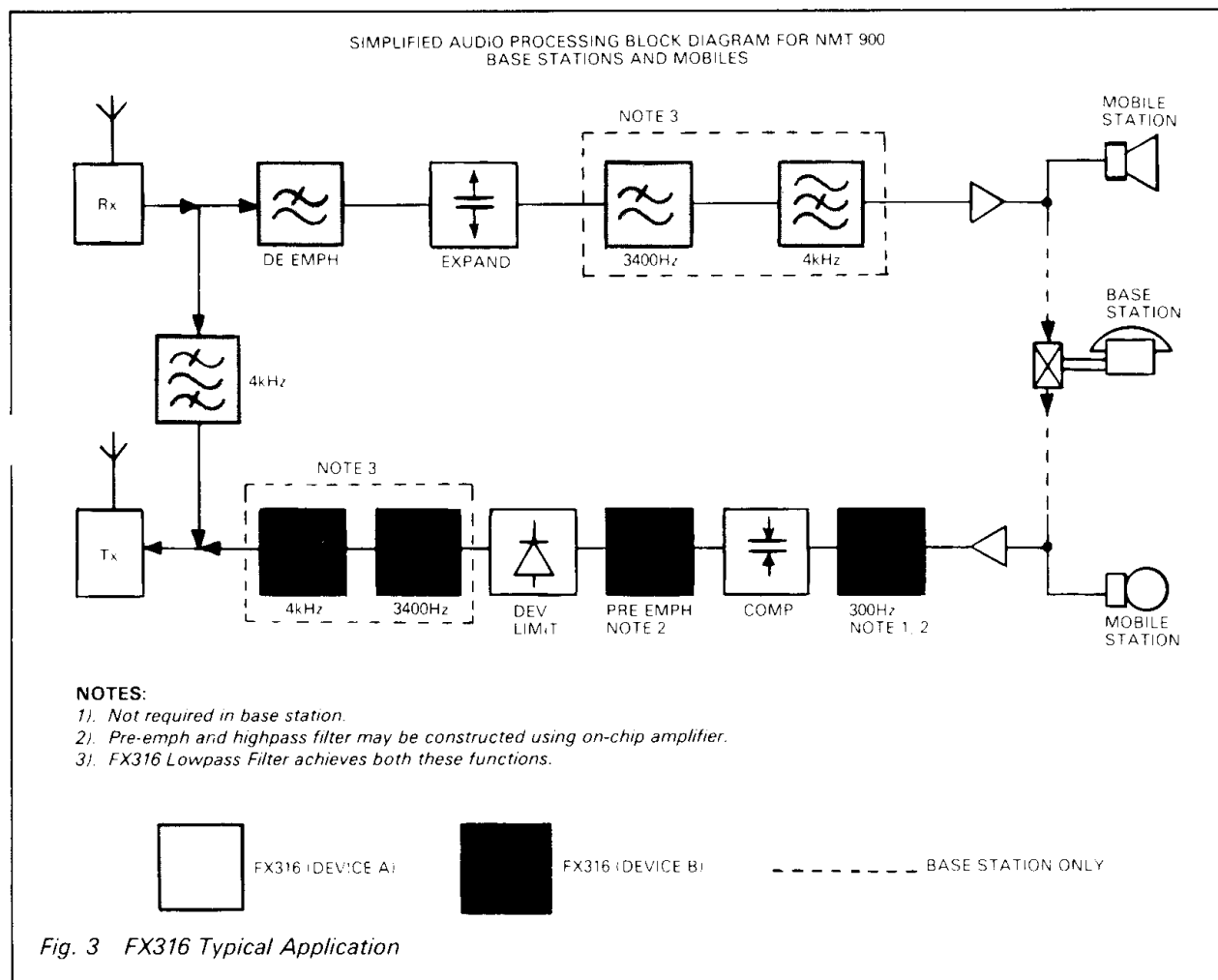

Fig. 3 FX316 Typical Application

Specification

Absolute Maximum Ratings

Exceeding the maximum rating can result in device damage. Operation of the device outside the operating limits is not implied.

Supply voltage	- 0.3V to 7.0V
Input voltage at any pin (ref $V_{SS} = 0V$)	- 0.3V to ($V_{DD} + 0.3V$)
Output sink/source current (total)	20mA
Operating temperature range: FX316J	- 30°C to + 85°C
FX316LG/LH	- 30°C to + 70°C
Storage temperature range: FX316J	- 55°C to + 125°C
FX316LG/LH	- 40°C to + 85°C
Maximum device dissipation:	All versions 100mW

Operating Limits

All characteristics measured using the following parameters unless otherwise specified:

$V_{DD} = 5V$, $T_{amb} = 25^{\circ}C$, $\phi = 1MHz$, $\Delta f_{\phi} = 0$, $f_{in} = 1kHz$.

Characteristics	See Note	Min	Typ	Max	Unit
Static Characteristics					
Supply voltage		4.5	5	5.5	V
Supply current (Enabled)		—	6.0	—	mA
Supply current (Disabled)		—	700	—	μA
Input impedance (Filters & Amplifier)		100	1000	—	$k\Omega$
Output impedance (Filters)		—	3	—	$k\Omega$
Output impedance (Amplifier open loop)		—	800	—	Ω
Output impedance (Amplifier closed loop)		—	6	—	Ω
Input logic '1'		3.5	—	—	V
Input logic '0'		—	—	1.5	V
Dynamic Characteristics					
Passband Ripple	(300-3000Hz) LP	5	—	2	dB
	(4kHz \pm 55Hz) BP	5	—	2	dB
Cut-off Frequency	(- 3dB) LP	4, 5	3000	3450	Hz
	(- 6dB) BP	4, 5	4200	—	Hz
Attenuation	(3800—4200Hz) LP	4, 5	36	46	dB
	(<2000Hz,>6000Hz) BP	4, 5	35	37	dB
Group Delay Distortion	(900-2100Hz) LP		—	80	μs
	(600-3000Hz) LP		—	450	μs
Output Noise (rms)	LP	1	—	1.6	mV
	BP	1	—	1	mV
Signal Input (rms)	LP	2	—	0.4	V
	BP	2	—	0.4	V
Insertion loss (1kHz)	LP		—	0	dB
	(4kHz) BP		—	0	dB
Aliasing Frequency			50	—	kHz
Inverting Amplifier					
Open loop gain	3	—	30	—	dB
Gain bandwidth product		—	1	—	MHz

- Notes:**
1. Measured with input a.c. s/c.
 2. 'MAX' figure specified for nominal 3% distortion (30dB SINAD).
'TYP' figure specified for minimum distortion (MAX SINAD).
 3. Relative to 1kHz 100mV rms input level.
 4. Refer to Figs. 4 and 5.
 5. Specified over the full operating voltage and temperature range.

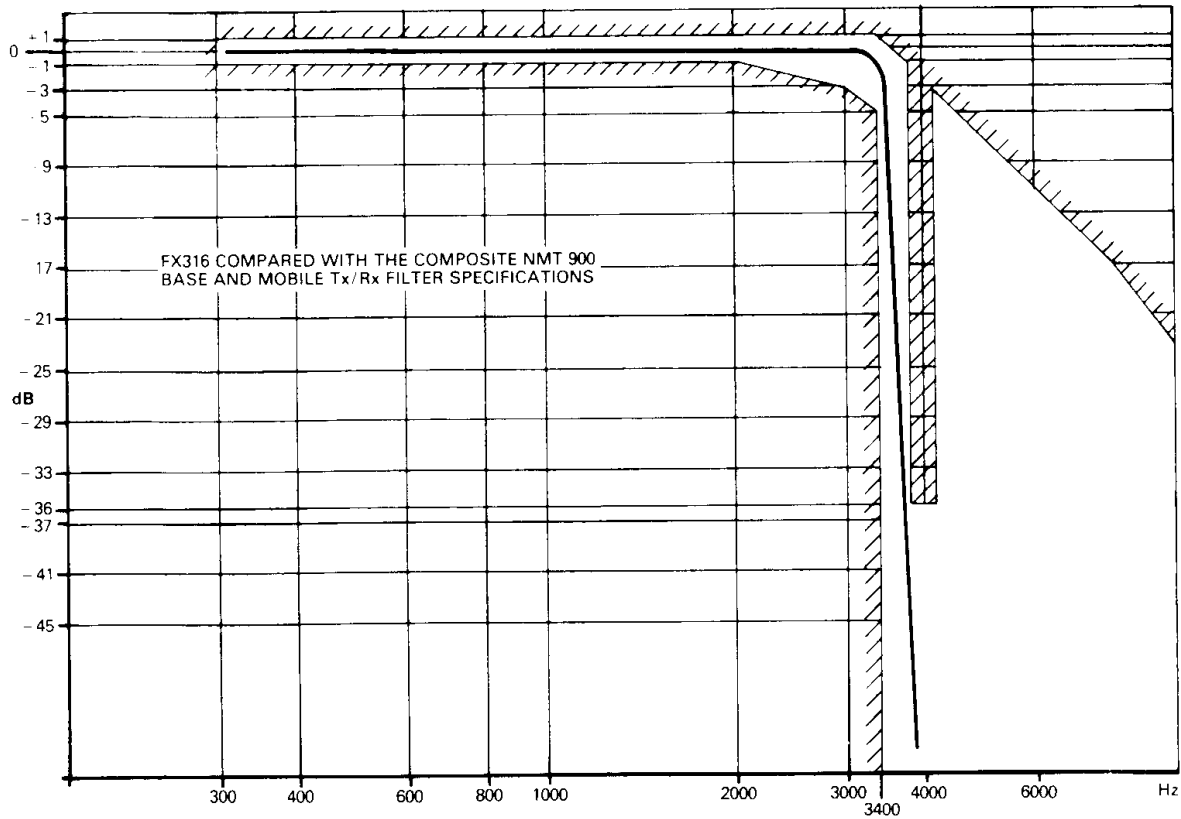

Fig. 4 Typical FX316 Lowpass Filter Response

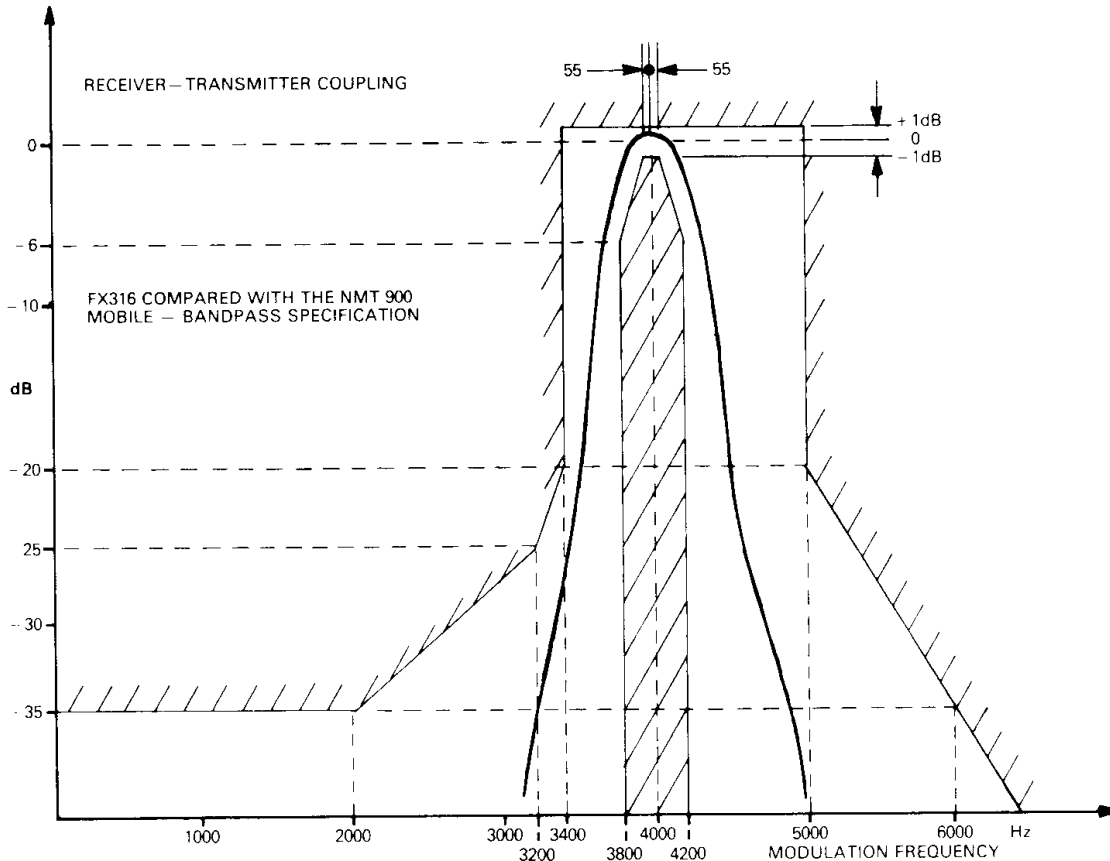
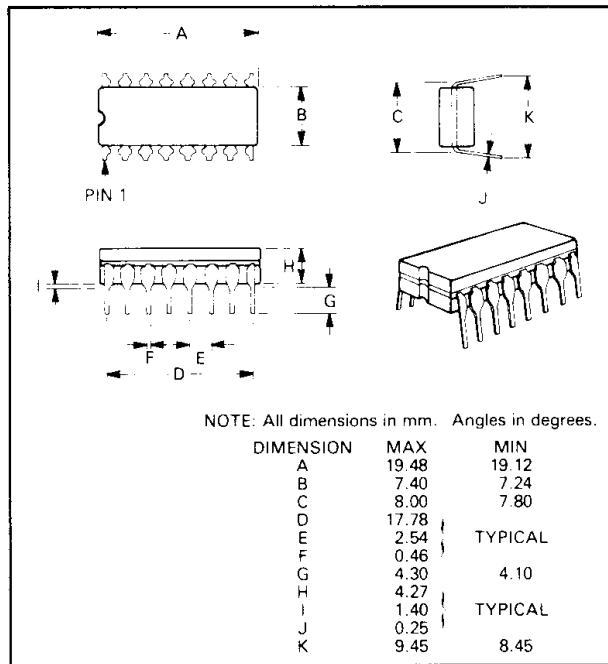

Fig. 5 Typical FX316 4kHz Bandpass Filter Response

Package Outlines

The FX316J, the cerdip package is illustrated in *Figure 6*. The 'LG' version is shown in *Figure 7* and the 'LH' version in *Figure 8*. The 'LG' and 'LH' packages are supplied in conductive trays for handling convenience. To allow complete identification, the FX316LG and LH packages have an indent adjacent to Pin 1 and a chamfered corner between Pins 3 and 4 for LG package, between Pins 4 and 5 for LH package. Pins number anti-clockwise when viewed from the top (indent side).

Fig. 6 FX316J DIL Package



Ordering Information

- FX316J 16-pin cerdip DIL
 FX316LG 24-pin quad plastic encapsulated, bent and cropped.
 FX316LH 28-lead plastic leaded chip carrier.

Handling Precautions

The FX316J/LG/LH is a CMOS LSI circuit which includes input protection. However, precautions should be taken to prevent static discharges which may cause damage.

Fig. 7 FX316LG Package

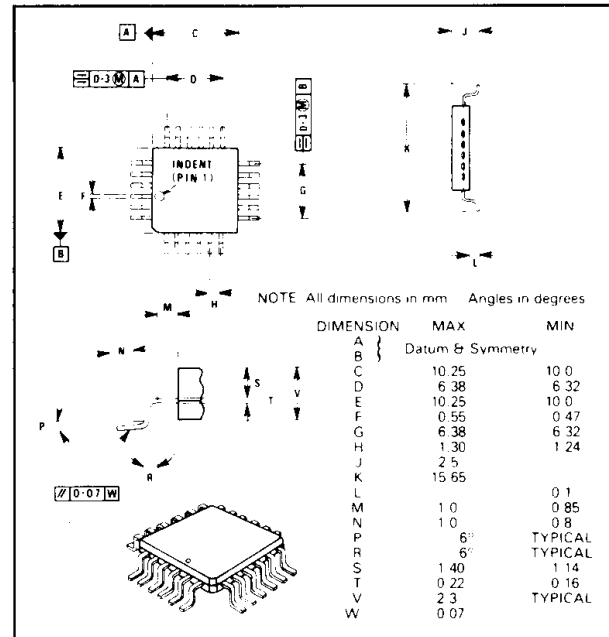
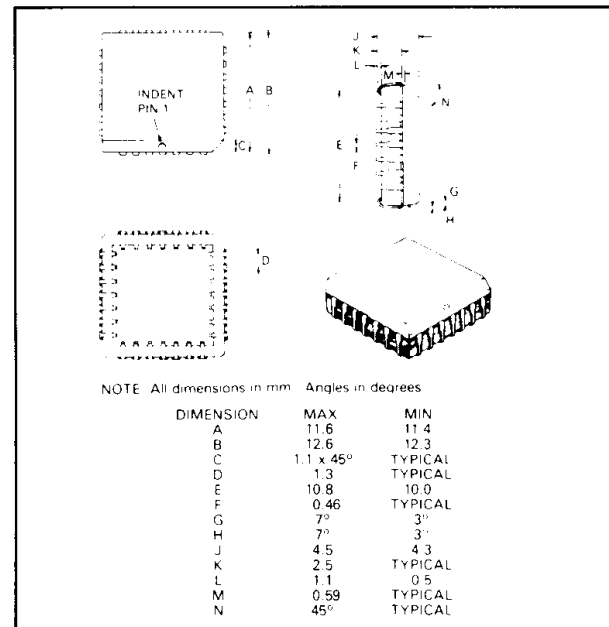

Fig. 8 FX316LH Package



CML does not assume any responsibility for the use of any circuitry described. No circuit patent licences are implied and CML reserves the right at any time without notice to change the said circuitry.