



HY5DU281622ET

128M(8Mx16) GDDR SDRAM

HY5DU281622ET

This document is a general product description and is subject to change without notice. Hynix Electronics does not assume any responsibility for use of circuits described. No patent licenses are implied.

Rev. 0.5 / Jan. 2005

1

Revision History

Revision No.	History	Draft Date	Remark
0.1	Defined target spec.	July 2003	
0.2	1) Insert Overshoot/Undershoot Specification 2) Insert tDSS/tDSH Parameter	Oct. 2003	
0.3	tPDEX value Change	Mar. 2004	
0.4	tRC_APCG changed to 12 clock from 11 clock at 166Mhz speed bin	Oct. 2004	
0.5	166Mhz speed bin delete, AC parameter change (tRC_APCG at 200Mhz)	Jan. 2005	

DESCRIPTION

The Hynix HY5DU281622ET is a 134,217,728-bit CMOS Double Data Rate(DDR) Synchronous DRAM, ideally suited for the point-to-point applications which require high densities and high bandwidth.

The Hynix 8Mx16 DDR SDRAMs offer fully synchronous operations referenced to both rising and falling edges of the clock. While all addresses and control inputs are latched on the rising edges of the CK (falling edges of the /CK), Data, Data strobes and Write data masks inputs are sampled on both rising and falling edges of it. The data paths are internally pipelined and 2-bit prefetched to achieve very high bandwidth. All input and output voltage levels are compatible with SSTL_2.

FEATURES

- 2.8V +/- 0.1V VDD and VDDQ power supply supports 400/375/350/333/300MHz
- 2.5V +/- 5% VDD and VDDQ power supply supports 275/250/200/166MHz
- All inputs and outputs are compatible with SSTL_2 interface
- JEDEC Standard 400 mil x 875 mil 66 Pin TSOP II, with 0.65mm pin pitch
- Fully differential clock inputs (CK, /CK) operation
- Double data rate interface
- Source synchronous - data transaction aligned to bidirectional data strobe (UDQS,LDQS)
- Data outputs on DQS edges when read (edged DQ) Data inputs on DQS centers when write (centered DQ)
- Data(DQ) and Write masks(DM) latched on the both rising and falling edges of the data strobe
- All addresses and control inputs except Data, Data strobes and Data masks latched on the rising edges of the clock
- Write mask byte controls by DM (UDM,LDM)
- Programmable /CAS Latency 5, 4 and 3 are supported
- Programmable Burst Length 2, 4 and 8 with both sequential and interleave mode
- Internal 4 bank operation with single pulsed /RAS
- tRAS Lock-Out function are supported
- Auto refresh and self refresh are supported
- 4096 refresh cycles / 32ms
- Full strength, Half strength and Weak Impedance driver options controlled by EMRS

ORDERING INFORMATION

Part No.	Power Supply	Clock Frequency	Max Data Rate	interface	Package
HY5DU281622ET-25	VDD/VDDQ=2.8V	400MHz	800Mbps/pin	SSTL_2	400 x 875mil ² 66 Pin TSOP II
HY5DU281622ET-26		375MHz	750Mbps/pin		
HY5DU281622ET-28		350MHz	700Mbps/pin		
HY5DU281622ET-30		333MHz	666Mbps/pin		
HY5DU281622ET-33		300MHz	600Mbps/pin		
HY5DU281622ET-36	VDD/VDDQ=2.5V	275MHz	550Mbps/pin		
HY5DU281622ET-4		250MHz	500Mbps/pin		
HY5DU281622ET-5		200MHz	400Mbps/pin		

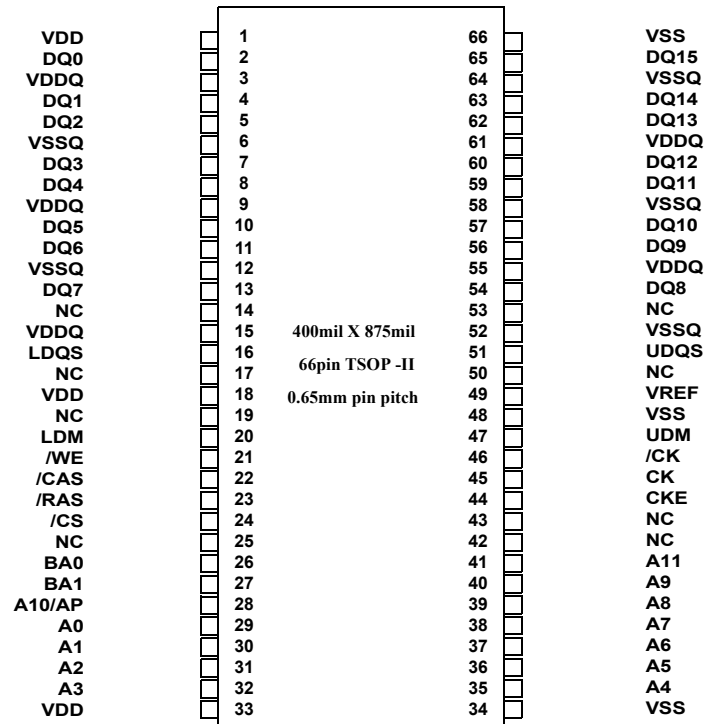
PIN CONFIGURATION (Top View)

ROW AND COLUMN ADDRESS TABLE

ITEMS	8Mx16
Organization	2M x 16 x 4banks
Row Address	A0 - A11
Column Address	A0-A8
Bank Address	BA0, BA1
Auto Precharge Flag	A10
Refresh	4K

PIN DESCRIPTION

PIN	TYPE	DESCRIPTION
CK, /CK	Input	Clock: CK and /CK are differential clock inputs. All address and control input signals are sampled on the crossing of the positive edge of CK and negative edge of /CK. Output (read) data is referenced to the crossings of CK and /CK (both directions of crossing).
CKE	Input	Clock Enable: CKE HIGH activates, and CKE LOW deactivates internal clock signals, and device input buffers and output drivers. Taking CKE LOW provides PRECHARGE POWER DOWN and SELF REFRESH operation (all banks idle), or ACTIVE POWER DOWN (row ACTIVE in any bank). CKE is synchronous for POWER DOWN entry and exit, and for SELF REFRESH entry and exit. CKE is asynchronous for output disable. CKE must be maintained high throughout READ and WRITE accesses. Input buffers, excluding CK, /CK and CKE are disabled during POWER DOWN. Input buffers, excluding CKE are disabled during SELF REFRESH. CKE is an SSTL_2 input, but will detect an LVCMOS LOW level after Vdd is applied.
/CS	Input	Chip Select : Enables or disables all inputs except CK, /CK, CKE, DQS and DM. All commands are masked when CS is registered high. CS provides for external bank selection on systems with multiple banks. CS is considered part of the command code.
BA0, BA1	Input	Bank Address Inputs: BA0 and BA1 define to which bank an ACTIVE, Read, Write or PRECHARGE command is being applied.
A0 ~ A11	Input	Address Inputs: Provide the row address for ACTIVE commands, and the column address and AUTO PRECHARGE bit for READ/WRITE commands, to select one location out of the memory array in the respective bank. A10 is sampled during a precharge command to determine whether the PRECHARGE applies to one bank (A10 LOW) or all banks (A10 HIGH). If only one bank is to be precharged, the bank is selected by BA0, BA1. The address inputs also provide the op code during a MODE REGISTER SET command. BA0 and BA1 define which mode register is loaded during the MODE REGISTER SET command (MRS or EMRS).
/RAS, /CAS, /WE	Input	Command Inputs: /RAS, /CAS and /WE (along with /CS) define the command being entered.
UDM, LDM	Input	Input Data Mask: DM is an input mask signal for write data. Input data is masked when DM is sampled HIGH along with that input data during a WRITE access. DM is sampled on both edges of DQS. Although DM pins are input only, the DM loading matches the DQ and DQS loading. LDM corresponds to the data on DQ0-Q7; UDM corresponds to the data on DQ8-Q15
UDQS, LDQS	I/O	Data Strobe: Output with read data, input with write data. Edge aligned with read data, centered in write data. Used to capture write data. LDQS corresponds to the data on DQ0-Q7; UDQS corresponds to the data on DQ8-Q15
DQ0 ~ DQ15	I/O	Data input / output pin : Data Bus
VDD/VSS	Supply	Power supply for internal circuits and input buffers.
VDDQ/VSSQ	Supply	Power supply for output buffers for noise immunity.
VREF	Supply	Reference voltage for inputs for SSTL interface.
NC	NC	No connection.

FUNCTIONAL BLOCK DIAGRAM

4Banks x 2Mbit x 16 I/O Double Data Rate Synchronous DRAM

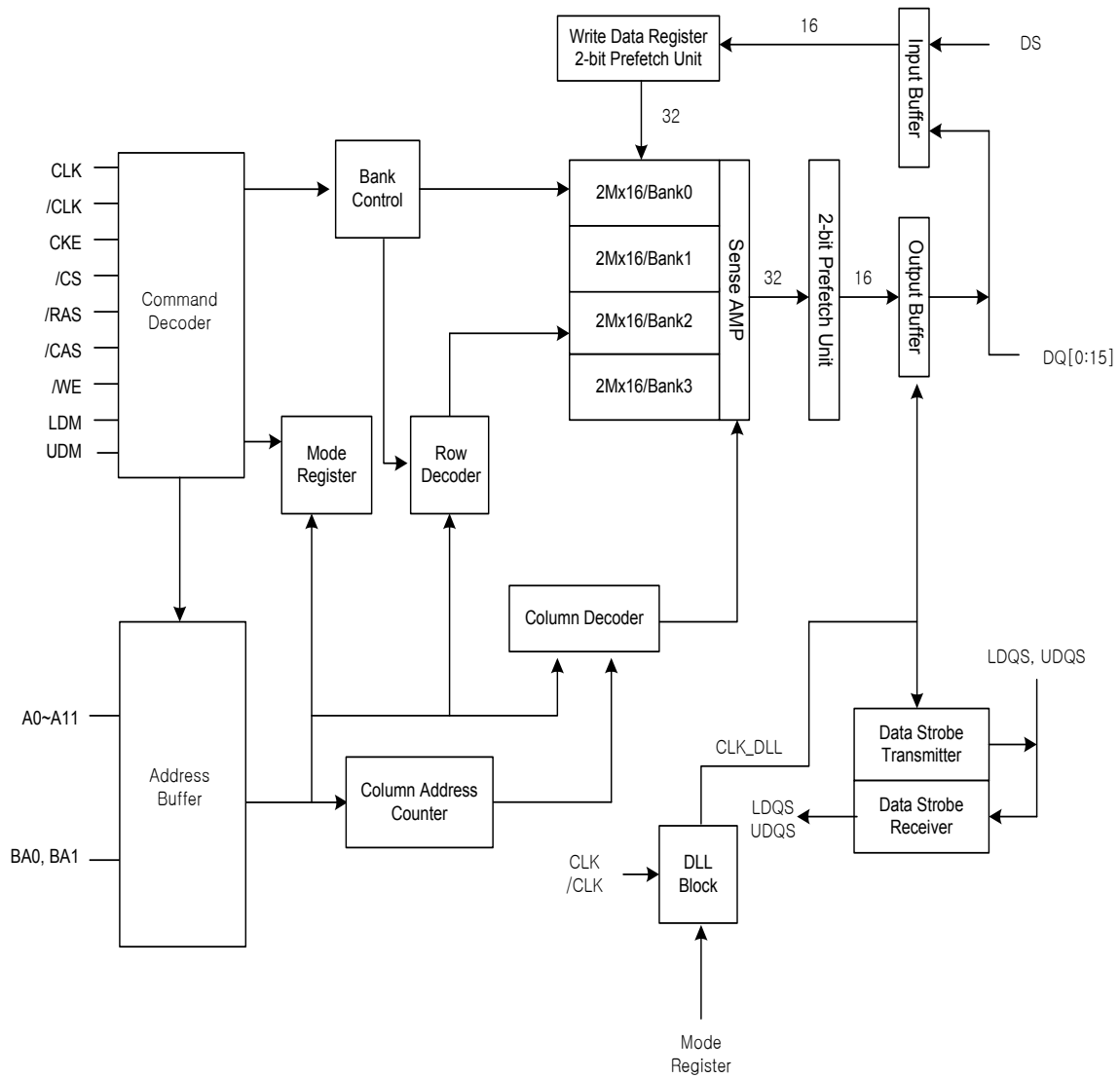

SIMPLIFIED COMMAND TRUTH TABLE

Command	CKEn-1	CKEn	CS	RAS	CAS	WE	ADDR	A10/AP	BA	Note
Extended Mode Register Set	H	X	L	L	L	L	OP code			1,2
Mode Register Set	H	X	L	L	L	L	OP code			1,2
Device Deselect	H	X	H	X	X	X	X			1
No Operation			L	H	H	H				
Bank Active	H	X	L	L	H	H	RA		V	1
Read	H	X	L	H	L	H	CA	L	V	1
Read with Autoprecharge								H		1,3
Write	H	X	L	H	L	L	CA	L	V	1
Write with Autoprecharge								H		1,4
Precharge All Banks	H	X	L	L	H	L	X	H	X	1,5
Precharge selected Bank								L	V	1
Read Burst Stop	H	X	L	H	H	L	X			1
Auto Refresh	H	H	L	L	L	H	X			1
Self Refresh	Entry	H	L	L	L	L	H	X		1
	Exit	L	H	H	X	X	X			1
Precharge Power Down Mode	Entry	H	L	H	X	X	X	X		1
				L	H	H	H			1
	Exit	L	H	H	X	X	X			1
				L	H	H	H			1
Active Power Down Mode	Entry	H	L	H	X	X	X	X		1
				L	V	V	V			1
	Exit	L	H	X						1

(H=Logic High Level, L=Logic Low Level, X=Don't Care, V=Valid Data Input, OP Code=Operand Code, NOP=No Operation)

Note :

- UDM, LDM states are Don't Care. Refer to below Write Mask Truth Table.(note 6)
- OP Code(Operand Code) consists of A0~A11 and BA0~BA1 used for Mode Register setting during Extended MRS or MRS. Before entering Mode Register Set mode, all banks must be in a precharge state and MRS command can be issued after tRP period from Prechagre command.
- If a Read with Auto-precharge command is detected by memory component in CK(n), then there will be no command presented to activate bank until CK(n+BL/2+tRP).
- If a Write with Auto-precharge command is detected by memory component in CK(n), then there will be no command presented to activate bank until CK(n+BL/2+1+tDPL+tRP). Last Data-In to Prechagre delay(tDPL) which is also called Write Recovery Time(tWR) is needed to guarantee that the last data have been completely written.
- If A10/AP is High when Precharge command being issued, BA0/BA1 are ignored and all banks are selected to be precharged.
- In here, Don't Care means logical value only, it doesn't mean 'Don't care for DC level of each signals'. DC level should be out of $V_{IHmin} \sim V_{ILmax}$

WRITE MASK TRUTH TABLE

Function	CKEn-1	CKEn	/CS, /RAS, /CAS, /WE	DM	ADDR	A8/ AP	BA	Note
Data Write	H	X	X	L		X		1,2,3
Data-In Mask	H	X	X	H		X		1,2,3

Note :

1. Write Mask command masks burst write data with reference to UDQS/LDQS and it is not related with read data.
2. LDM corresponds to the data on DQ0-Q7 and UDM corresponds to the data on DQ8-Q15
3. In here, Don't Care means logical value only, it doesn't mean 'Don't care for DC level of each signals'. DC level should be out of $V_{IHmin} \sim V_{ILmax}$

OPERATION COMMAND TRUTH TABLE - I

Current State	/CS	/RAS	/CAS	/WE	Address	Command	Action
IDLE	H	X	X	X	X	DSEL	NOP or power down ³
	L	H	H	H	X	NOP	NOP or power down ³
	L	H	H	L	X	BST	ILLEGAL ⁴
	L	H	L	H	BA, CA, AP	READ/READAP	ILLEGAL ⁴
	L	H	L	L	BA, CA, AP	WRITE/WRITEAP	ILLEGAL ⁴
	L	L	H	H	BA, RA	ACT	Row Activation
	L	L	H	L	BA, AP	PRE/PALL	NOP
	L	L	L	H	X	AREF/SREF	Auto Refresh or Self Refresh ⁵
	L	L	L	L	OPCODE	MRS	Mode Register Set
ROW ACTIVE	H	X	X	X	X	DSEL	NOP
	L	H	H	H	X	NOP	NOP
	L	H	H	L	X	BST	ILLEGAL ⁴
	L	H	L	H	BA, CA, AP	READ/READAP	Begin read : optional AP ⁶
	L	H	L	L	BA, CA, AP	WRITE/WRITEAP	Begin write : optional AP ⁶
	L	L	H	H	BA, RA	ACT	ILLEGAL ⁴
	L	L	H	L	BA, AP	PRE/PALL	Precharge ⁷
	L	L	L	H	X	AREF/SREF	ILLEGAL ¹¹
	L	L	L	L	OPCODE	MRS	ILLEGAL ¹¹
READ	H	X	X	X	X	DSEL	Continue burst to end
	L	H	H	H	X	NOP	Continue burst to end
	L	H	H	L	X	BST	Terminate burst
	L	H	L	H	BA, CA, AP	READ/READAP	Term burst, new read:optional AP ⁸
	L	H	L	L	BA, CA, AP	WRITE/WRITEAP	ILLEGAL
	L	L	H	H	BA, RA	ACT	ILLEGAL ⁴
	L	L	H	L	BA, AP	PRE/PALL	Term burst, precharge
	L	L	L	H	X	AREF/SREF	ILLEGAL ¹¹
	L	L	L	L	OPCODE	MRS	ILLEGAL ¹¹
WRITE	H	X	X	X	X	DSEL	Continue burst to end
	L	H	H	H	X	NOP	Continue burst to end
	L	H	H	L	X	BST	ILLEGAL ⁴
	L	H	L	H	BA, CA, AP	READ/READAP	Term burst, new read:optional AP ⁸
	L	H	L	L	BA, CA, AP	WRITE/WRITEAP	Term burst, new write:optional AP

OPERATION COMMAND TRUTH TABLE - II

Current State	/CS	/RAS	/CAS	/WE	Address	Command	Action
WRITE	L	L	H	H	BA, RA	ACT	ILLEGAL ⁴
	L	L	H	L	BA, AP	PRE/PALL	Term burst, precharge
	L	L	L	H	X	AREF/SREF	ILLEGAL ¹¹
	L	L	L	L	OPCODE	MRS	ILLEGAL ¹¹
READ WITH AUTOPRE-CHARGE	H	X	X	X	X	DSEL	Continue burst to end
	L	H	H	H	X	NOP	Continue burst to end
	L	H	H	L	X	BST	ILLEGAL
	L	H	L	H	BA, CA, AP	READ/READAP	ILLEGAL ¹⁰
	L	H	L	L	BA, CA, AP	WRITE/WRITEAP	ILLEGAL ¹⁰
	L	L	H	H	BA, RA	ACT	ILLEGAL ^{4,10}
	L	L	H	L	BA, AP	PRE/PALL	ILLEGAL ^{4,10}
	L	L	L	H	X	AREF/SREF	ILLEGAL ¹¹
WRITE AUTOPRE-CHARGE	H	X	X	X	X	DSEL	Continue burst to end
	L	H	H	H	X	NOP	Continue burst to end
	L	H	H	L	X	BST	ILLEGAL
	L	H	L	H	BA, CA, AP	READ/READAP	ILLEGAL ¹⁰
	L	H	L	L	BA, CA, AP	WRITE/WRITEAP	ILLEGAL ¹⁰
	L	L	H	H	BA, RA	ACT	ILLEGAL ^{4,10}
	L	L	H	L	BA, AP	PRE/PALL	ILLEGAL ^{4,10}
	L	L	L	H	X	AREF/SREF	ILLEGAL ¹¹
PRE-CHARGE	H	X	X	X	X	DSEL	NOP-Enter IDLE after tRP
	L	H	H	H	X	NOP	NOP-Enter IDLE after tRP
	L	H	H	L	X	BST	ILLEGAL ⁴
	L	H	L	H	BA, CA, AP	READ/READAP	ILLEGAL ^{4,10}
	L	H	L	L	BA, CA, AP	WRITE/WRITEAP	ILLEGAL ^{4,10}
	L	L	H	H	BA, RA	ACT	ILLEGAL ^{4,10}
	L	L	H	L	BA, AP	PRE/PALL	NOP-Enter IDLE after tRP
	L	L	L	H	X	AREF/SREF	ILLEGAL ¹¹
L	L	L	L	OPCODE	MRS	ILLEGAL ¹¹	

OPERATION COMMAND TRUTH TABLE - III

Current State	/CS	/RAS	/CAS	/WE	Address	Command	Action
ROW ACTIVATING	H	X	X	X	X	DSEL	NOP - Enter ROW ACT after tRCD
	L	H	H	H	X	NOP	NOP - Enter ROW ACT after tRCD
	L	H	H	L	X	BST	ILLEGAL ⁴
	L	H	L	H	BA, CA, AP	READ/READAP	ILLEGAL ^{4,10}
	L	H	L	L	BA, CA, AP	WRITE/WRITEAP	ILLEGAL ^{4,10}
	L	L	H	H	BA, RA	ACT	ILLEGAL ^{4,9,10}
	L	L	H	L	BA, AP	PRE/PALL	ILLEGAL ^{4,10}
	L	L	L	H	X	AREF/SREF	ILLEGAL ¹¹
	L	L	L	L	OPCODE	MRS	ILLEGAL ¹¹
WRITE RECOVERING	H	X	X	X	X	DSEL	NOP - Enter ROW ACT after tWR
	L	H	H	H	X	NOP	NOP - Enter ROW ACT after tWR
	L	H	H	L	X	BST	ILLEGAL ⁴
	L	H	L	H	BA, CA, AP	READ/READAP	ILLEGAL
	L	H	L	L	BA, CA, AP	WRITE/WRITEAP	ILLEGAL
	L	L	H	H	BA, RA	ACT	ILLEGAL ^{4,10}
	L	L	H	L	BA, AP	PRE/PALL	ILLEGAL ^{4,11}
	L	L	L	H	X	AREF/SREF	ILLEGAL ¹¹
	L	L	L	L	OPCODE	MRS	ILLEGAL ¹¹
WRITE RECOVERING WITH AUTOPRE-CHARGE	H	X	X	X	X	DSEL	NOP - Enter precharge after tDPL
	L	H	H	H	X	NOP	NOP - Enter precharge after tDPL
	L	H	H	L	X	BST	ILLEGAL ⁴
	L	H	L	H	BA, CA, AP	READ/READAP	ILLEGAL ^{4,8,10}
	L	H	L	L	BA, CA, AP	WRITE/WRITEAP	ILLEGAL ^{4,10}
	L	L	H	H	BA, RA	ACT	ILLEGAL ^{4,10}
	L	L	H	L	BA, AP	PRE/PALL	ILLEGAL ^{4,11}
	L	L	L	H	X	AREF/SREF	ILLEGAL ¹¹
	L	L	L	L	OPCODE	MRS	ILLEGAL ¹¹
REFRESHING	H	X	X	X	X	DSEL	NOP - Enter IDLE after tRC
	L	H	H	H	X	NOP	NOP - Enter IDLE after tRC
	L	H	H	L	X	BST	ILLEGAL ¹¹
	L	H	L	H	BA, CA, AP	READ/READAP	ILLEGAL ¹¹

OPERATION COMMAND TRUTH TABLE - IV

Current State	/CS	/RAS	/CAS	/WE	Address	Command	Action
WRITE	L	H	L	L	BA, CA, AP	WRITE/WRITEAP	ILLEGAL ¹¹
	L	L	H	H	BA, RA	ACT	ILLEGAL ¹¹
	L	L	H	L	BA, AP	PRE/PALL	ILLEGAL ¹¹
	L	L	L	H	X	AREF/SREF	ILLEGAL ¹¹
	L	L	L	L	OPCODE	MRS	ILLEGAL ¹¹
MODE REGISTER ACCESSING	H	X	X	X	X	DSEL	NOP - Enter IDLE after tMRD
	L	H	H	H	X	NOP	NOP - Enter IDLE after tMRD
	L	H	H	L	X	BST	ILLEGAL ¹¹
	L	H	L	H	BA, CA, AP	READ/READAP	ILLEGAL ¹¹
	L	H	L	L	BA, CA, AP	WRITE/WRITEAP	ILLEGAL ¹¹
	L	L	H	H	BA, RA	ACT	ILLEGAL ¹¹
	L	L	H	L	BA, AP	PRE/PALL	ILLEGAL ¹¹
	L	L	L	H	X	AREF/SREF	ILLEGAL ¹¹
	L	L	L	L	OPCODE	MRS	ILLEGAL ¹¹

Note :

1. H - Logic High Level, L - Logic Low Level, X - Don't Care, V - Valid Data Input, BA - Bank Address, AP - AutoPrecharge Address, CA - Column Address, RA - Row Address, NOP - NO Operation.(see note 12)
2. All entries assume that CKE was active(high level) during the preceding clock cycle.
3. If both banks are idle and CKE is inactive(low level), then in power down mode.
4. Illegal to bank in specified state. Function may be legal in the bank indicated by Bank Address(BA) depending on the state of that bank.
5. If both banks are idle and CKE is inactive(low level), then self refresh mode.
6. Illegal if tRCD is not met.
7. Illegal if tRAS is not met.
8. Must satisfy bus contention, bus turn around, and/or write recovery requirements.
9. Illegal if tRRD is not met.
10. Illegal for single bank, but legal for other banks in multi-bank devices.
11. Illegal for all banks.
12. In here, Don't Care means logical value only, it doesn't mean 'Don't care for DC level of each signals'. DC level should be out of $V_{IHmin} \sim V_{ILmax}$

CKE FUNCTION TRUTH TABLE

Current State	CKEn-1	CKEn	/CS	/RAS	/CAS	/WE	/ADD	Action
SELF REFRESH ¹	H	X	X	X	X	X	X	INVALID
	L	H	H	X	X	X	X	Exit self refresh, enter idle after tSREX
	L	H	L	H	H	H	X	Exit self refresh, enter idle after tSREX
	L	H	L	H	H	L	X	ILLEGAL
	L	H	L	H	L	X	X	ILLEGAL
	L	H	L	L	X	X	X	ILLEGAL
	L	L	X	X	X	X	X	NOP, continue self refresh
POWER DOWN ²	H	X	X	X	X	X	X	INVALID
	L	H	H	X	X	X	X	Exit power down, enter idle
	L	H	L	H	H	H	X	Exit power down, enter idle
	L	H	L	H	H	L	X	ILLEGAL
	L	H	L	H	L	X	X	ILLEGAL
	L	H	L	L	X	X	X	ILLEGAL
	L	L	X	X	X	X	X	NOP, continue power down mode
ALL BANKS IDLE ⁴	H	H	X	X	X	X	X	See operation command truth table
	H	L	L	L	L	H	X	Enter self refresh
	H	L	H	X	X	X	X	Exit power down
	H	L	L	H	H	H	X	Exit power down
	H	L	L	H	H	L	X	ILLEGAL
	H	L	L	H	L	X	X	ILLEGAL
	H	L	L	L	H	X	X	ILLEGAL
	H	L	L	L	L	L	X	ILLEGAL
ANY STATE OTHER THAN ABOVE	L	L	X	X	X	X	X	NOP
	H	H	X	X	X	X	X	See operation command truth table
	H	L	X	X	X	X	X	ILLEGAL ⁵
	L	H	X	X	X	X	X	INVALID
	L	L	X	X	X	X	X	INVALID

Note :

When CKE=L, all DQ and UDQS/LDQS should be in Hi-Z state.

1. CKE and /CS must be kept high for a minimum of 200 stable input clocks before issuing any command.
2. All commands can be stored after 2 clocks from low to high transition of CKE.
3. Illegal, if CK is suspended or stopped during the power down mode.
4. Self refresh can be asserted only from the all banks idle state.
5. Disabling CK may cause malfunction of any banks which are in active state.

SIMPLIFIED STATE DIAGRAM

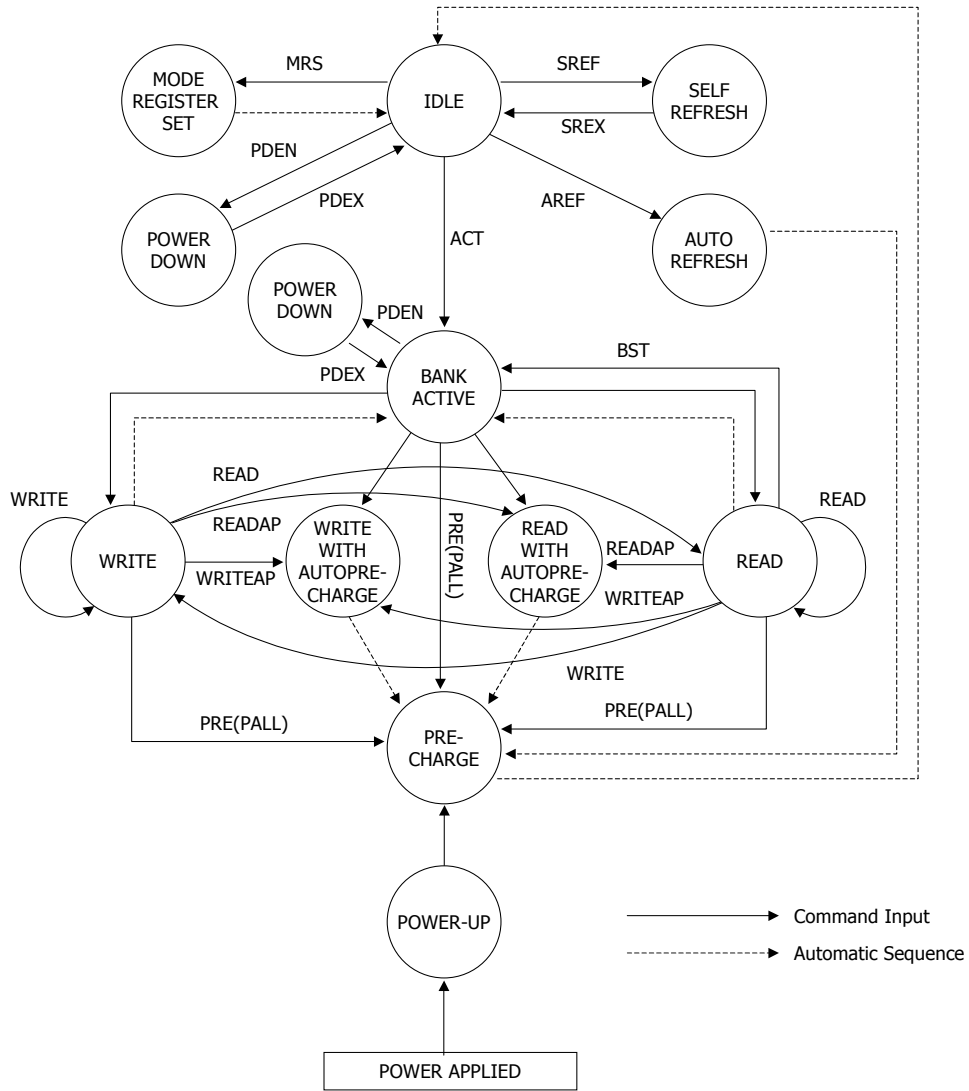

POWER-UP SEQUENCE AND DEVICE INITIALIZATION

DDR SDRAMs must be powered up and initialized in a predefined manner. Operational procedures other than those specified may result in undefined operation. Except for CKE, inputs are not recognized as valid until after VREF is applied. CKE is an SSTL_2 input, but will detect an LVCMOS LOW level after VDD is applied. Maintaining an LVCMOS LOW level on CKE during power-up is required to guarantee that the DQ and DQS outputs will be in the High-Z state, where they will remain until driven in normal operation (by a read access). After all power supply and reference voltages are stable, and the clock is stable, the DDR SDRAM requires a 200µs delay prior to applying an executable command.

Once the 200µs delay has been satisfied, a DESELECT or NOP command should be applied, and CKE should be brought HIGH. Following the NOP command, a PRECHARGE ALL command should be applied. Next a EXTENDED MODE REGISTER SET command should be issued for the Extended Mode Register, to enable the DLL, then a MODE REGISTER SET command should be issued for the Mode Register, to reset the DLL, and to program the operating parameters. After the DLL reset, tXSRD(DLL locking time) should be satisfied for read command. After the Mode Register set command, a PRECHARGE ALL command should be applied, placing the device in the all banks idle state.

Once in the idle state, two AUTO REFRESH cycles must be performed. Additionally, a MODE REGISTER SET command for the Mode Register, with the reset DLL bit deactivated low (i.e. to program operating parameters without resetting the DLL) must be performed. Following these cycles, the DDR SDRAM is ready for normal operation.

1. Apply power - VDD, VDDQ, VTT, VREF in the following power up sequencing and attempt to maintain CKE at LVCMOS low state. (All the other input pins may be undefined.)

No power sequencing is specified during power up or power down given the following criteria :

- VDD and VDDQ are driven from a single power converter output.
- VTT is limited to 1.4025V (reflecting VDDQ(max)/2 + 50mV VREF variation + 40mV VTT variation).
- VREF tracks VDDQ/2.
- If the above criteria cannot be met by the system design, then the following sequencing and voltage relationship must be adhered to during power up :

Voltage description	Sequencing	Voltage relationship to avoid latch-up
VDDQ	After or with VDD	< VDD + 0.3V
VTT	After or with VDDQ	< VDDQ + 0.3V
VREF	After or with VDDQ	< VDDQ + 0.3V

2. Start clock and maintain stable clock for a minimum of 200µsec.
3. After stable power and clock, apply NOP or DESELECT conditionS and take CKE high.
4. Following the NOP command, a PRECHARGE ALL command should be applied
5. Issue Extended Mode Register Set (EMRS) to enable DLL.
6. Issue Mode Register Set (MRS) to reset DLL and set device to idle state with bit A8=high. (An additional 200 cycles(tXSRD) of clock are required for locking DLL)
7. Issue Precharge commands for all banks of the device.
8. Issue 2 or more Auto Refresh commands.

- Issue a Mode Register Set command to initialize the mode register with bit A8 = Low.

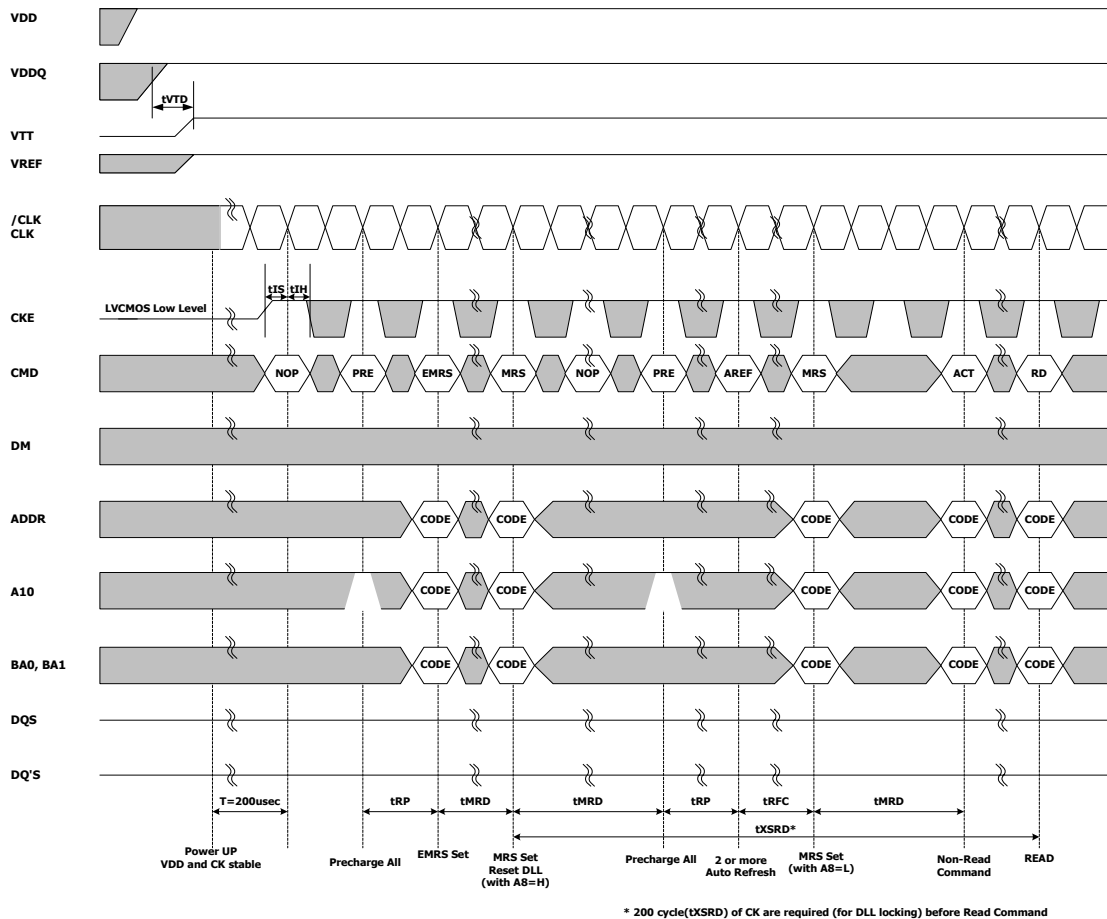
Power-Up Sequence

MODE REGISTER SET (MRS)

The mode register is used to store the various operating modes such as /CAS latency, addressing mode, burst length, burst type, test mode, DLL reset. The mode register is program via MRS command. This command is issued by the low signals of /RAS, /CAS, /CS, /WE and BA0. This command can be issued only when all banks are in idle state and CKE must be high at least one cycle before the Mode Register Set Command can be issued. Two cycles are required to write the data in mode register. During the the MRS cycle, any command cannot be issued. Once mode register field is determined, the information will be held until resetted by another MRS command.

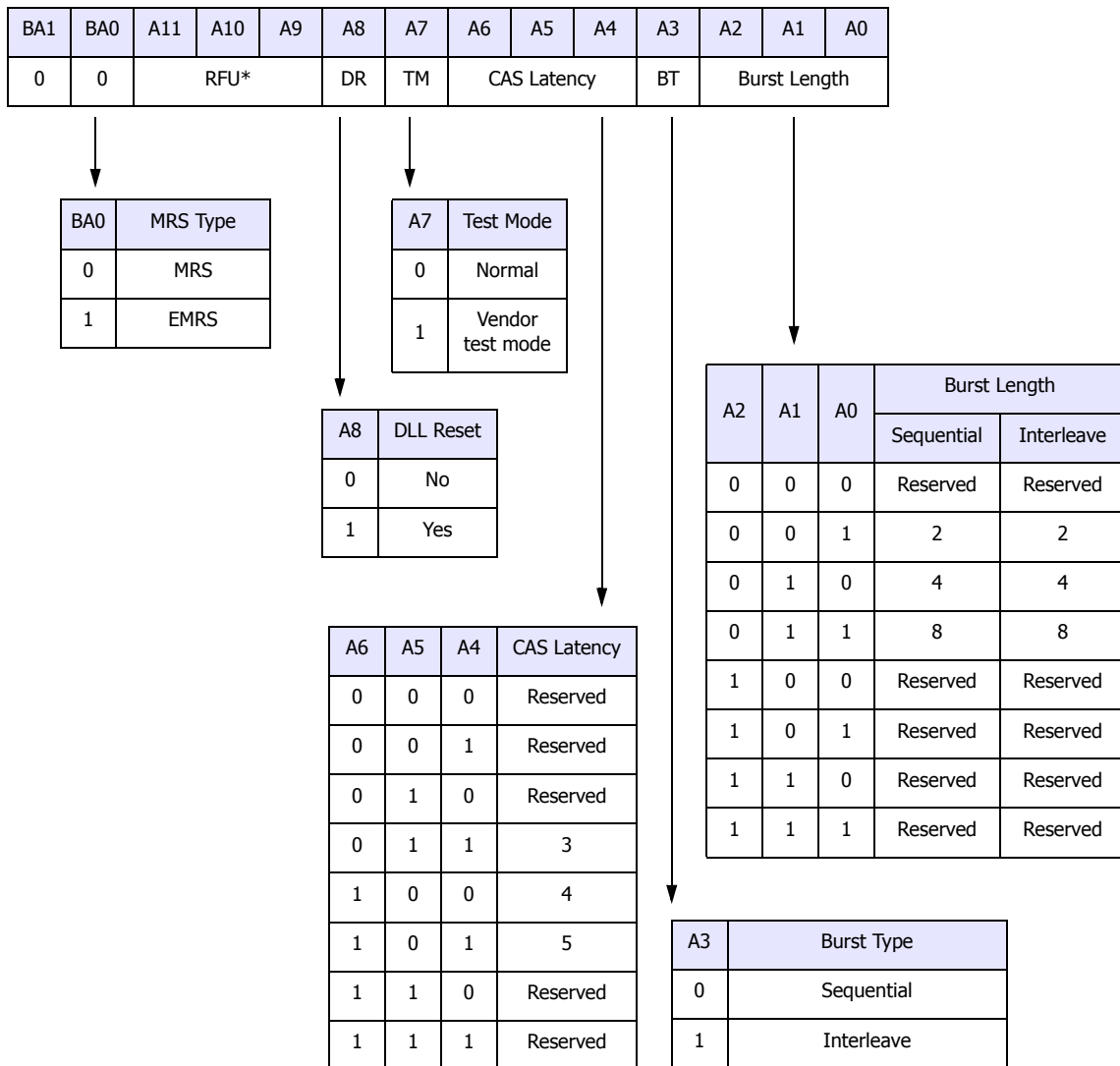

* All bits in RFU address fields must be programmed to Zero, all other states are reserved for future usage.
 And, if MRS/EMRS are programmed with 'Reserved' code, it could be the cause of mal-function.

BURST DEFINITION

Burst Length	Starting Address (A2,A1,A0)	Sequential	Interleave
2	XX0	0, 1	0, 1
	XX1	1, 0	1, 0
4	X00	0, 1, 2, 3	0, 1, 2, 3
	X01	1, 2, 3, 0	1, 0, 3, 2
	X10	2, 3, 0, 1	2, 3, 0, 1
	X11	3, 0, 1, 2	3, 2, 1, 0
8	000	0, 1, 2, 3, 4, 5, 6, 7	0, 1, 2, 3, 4, 5, 6, 7
	001	1, 2, 3, 4, 5, 6, 7, 0	1, 0, 3, 2, 5, 4, 7, 6
	010	2, 3, 4, 5, 6, 7, 0, 1	2, 3, 0, 1, 6, 7, 4, 5
	011	3, 4, 5, 6, 7, 0, 1, 2	3, 2, 1, 0, 7, 6, 5, 4
	100	4, 5, 6, 7, 0, 1, 2, 3	4, 5, 6, 7, 0, 1, 2, 3
	101	5, 6, 7, 0, 1, 2, 3, 4	5, 4, 7, 6, 1, 0, 3, 2
	110	6, 7, 0, 1, 2, 3, 4, 5	6, 7, 4, 5, 2, 3, 0, 1
	111	0, 1, 2, 3, 4, 5, 6, 7	7, 6, 5, 4, 3, 2, 1, 0

BURST LENGTH & TYPE

Read and write accesses to the DDR SDRAM are burst oriented, with the burst length being programmable. The burst length determines the maximum number of column locations that can be accessed for a given Read or Write command. Burst lengths of 2, 4 or 8 locations are available for both the sequential and the interleaved burst types. Reserved states should not be used, as unknown operation or incompatibility with future versions may result.

When a Read or Write command is issued, a block of columns equal to the burst length is effectively selected. All accesses for that burst take place within this block, meaning that the burst wraps within the block if a boundary is reached. The block is uniquely selected by A1-Ai when the burst length is set to two, by A2-Ai when the burst length is set to four and by A3-Ai when the burst length is set to eight (where Ai is the most significant column address bit for a given configuration). The remaining (least significant) address bit(s) is (are) used to select the starting location within the block. The programmed burst length applies to both Read and Write bursts.

Accesses within a given burst may be programmed to be either sequential or interleaved; this is referred to as the burst type and is selected via bit A3. The ordering of accesses within a burst is determined by the burst length, the burst type and the starting column address, as shown in Burst Definitionon Table

CAS LATENCY

The Read latency or CAS latency is the delay in clock cycles between the registration of a Read command and the availability of the first burst of output data. The latency can be programmed 3 or 4 clocks.

If a Read command is registered at clock edge n , and the latency is m clocks, the data is available nominally coincident with clock edge $n + m$.

Reserved states should not be used as unknown operation or incompatibility with future versions may result.

DLL RESET

The DLL must be enabled for normal operation. DLL enable is required during power up initialization, and upon returning to normal operation after having disabled the DLL for the purpose of debug or evaluation. The DLL is automatically disabled when entering self refresh operation and is automatically re-enabled upon exit of self refresh operation. Any time the DLL is enabled, 200 clock cycles must occur to allow time for the internal clock to lock to the externally applied clock before an any command can be issued.

OUTPUT DRIVER IMPEDANCE CONTROL

This device supports both Half strength driver and Matched impedance driver, intended for lighter load and/or point-to-point environments. Half strength driver is to define about 50% of Full drive strength which is specified to be SSTL_2, Class II, and Matched impedance driver, about 30% of Full drive strength.

EXTENDED MODE REGISTER SET (EMRS)

The Extended Mode Register controls functions beyond those controlled by the Mode Register; these additional functions include DLL enable/disable, output driver strength selection(optional). These functions are controlled via the bits shown below. The Extended Mode Register is programmed via the Mode Register Set command (BA0=1 and BA1=0) and will retain the stored information until it is programmed again or the device loses power.

The Extended Mode Register must be loaded when all banks are idle and no bursts are in progress, and the controller must wait the specified time before initiating any subsequent operation. Violating either of these requirements will result in unspecified operation.

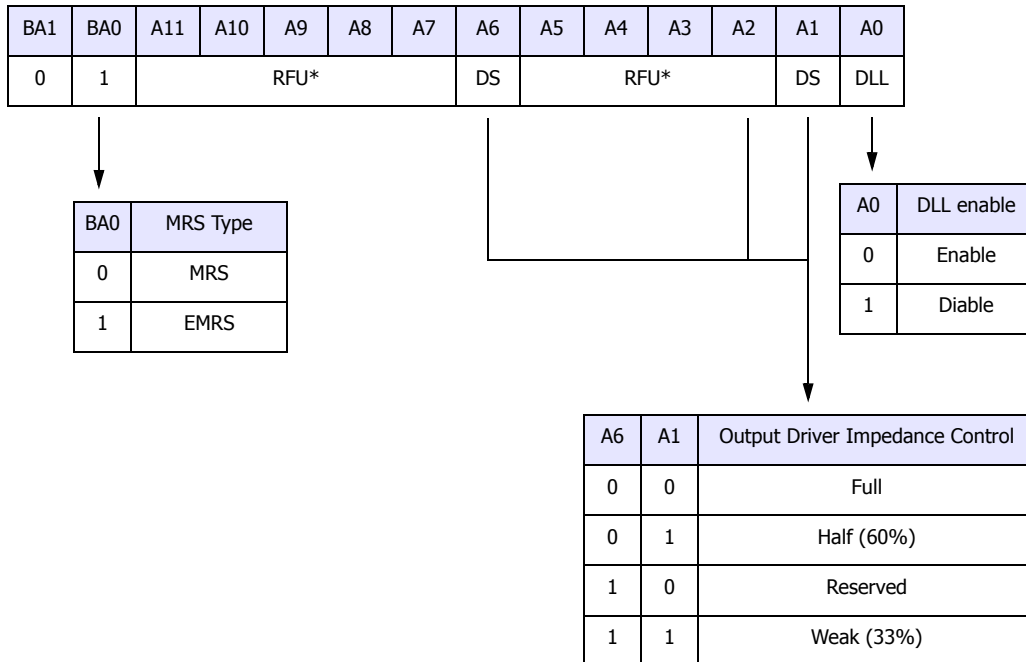

* All bits in RFU address fields must be programmed to Zero, all other states are reserved for future usage.

ABSOLUTE MAXIMUM RATINGS

Parameter	Symbol	Rating	Unit
Ambient Temperature	TA	0 ~ 70	°C
Storage Temperature	TSTG	-55 ~ 125	°C
Voltage on Any Pin relative to VSS	VIN, VOUT	-0.5 ~ 3.6	V
Voltage on VDD relative to VSS	VDD	-0.5 ~ 3.6	V
Voltage on VDDQ relative to VSS	VDDQ	-0.5 ~ 3.6	V
Output Short Circuit Current	IOS	50	mA
Power Dissipation	PD	2	W
Soldering Temperature - Time	TSOLDER	260 · 10	°C · sec

Note : Operation at above absolute maximum rating can adversely affect device reliability

DC OPERATING CONDITIONS (TA=0 to 70°C, Voltage referenced to VSS = 0V)

Parameter	Symbol	Min	Typ	Max	Unit	Note
Power Supply Voltage	VDD	2.375	2.5	2.625	V	1,4
	VDDQ	2.375	2.5	2.625	V	1,4
	VDD	2.7	2.8	2.9	V	1,5
	VDDQ	2.7	2.8	2.9	V	1,5
Input High Voltage	VIH	VREF + 0.15	-	VDDQ + 0.3	V	
Input Low Voltage	VIL	-0.3	-	VREF - 0.15	V	
Termination Voltage	VTT	VREF - 0.04	VREF	VREF + 0.04	V	3
Reference Voltage	VREF	0.49*VDDQ	0.5*VDDQ	0.51*VDDQ	V	2

- Note :**
- VDDQ must not exceed the level of VDD.
 - VREF is expected to be equal to 0.5*VDDQ of the transmitting device, and to track variations in the DC level of the same. Peak to peak noise on VREF may not exceed $\pm 2\%$ of the DC value.
 - VTT is expected to be set equal to VREF, and Vtt of the transmitting device must track VREF of the receiving device.
 - Supports 275/ 250/ 200/166Mhz
 - Supports 400/375/350/333/300Mhz

DC CHARACTERISTICS I (TA=0 to 70°C, Voltage referenced to VSS = 0V)

Parameter	Symbol	Min	Max	Unit	Note
Input Leakage Current	ILI	-5	5	uA	1
Output Leakage Current	ILO	-5	5	uA	2
Output High Voltage	VOH	VTT + 0.76	-	V	IOH = -15.2mA,2
Output Low Voltage	VOL	-	VTT - 0.76	V	IOL = +15.2mA,2

- Note :**
- VIN = 0 to 3.6V, All other pins are not tested under VIN =0V.
 - DOUT is disabled, VOUT=0 to 2.625V, It means, output logic high voltage and low voltage is depend on output channel conditions.

DC CHARACTERISTICS II (TA=0 to 70°C, Voltage referenced to VSS = 0V)

Parameter	Symbol	Test Condition	Speed					Unit	Note
			25	26	28	30	33		
Operating Current	IDD0	One bank; Active - Precharge; tRC=tRC(min); tCK=tCK(min); DQ,DM and DQS inputs changing twice per clock cycle; address and control inputs changing once per clock cycle	230	220	210	200	190	mA	1
Operating Current	IDD1	Burst length=4, One bank active tRC ≥ tRC(min), IOL=0mA	230	220	210	200	190	mA	1
Precharge Standby Current in Power Down Mode	IDD2P	CKE ≤ VIL(max), tCK=min	40	40	40	40	40	mA	
Precharge Standby Current in Non Power Down Mode	IDD2N	CKE ≥ VIH(min), /CS ≥ VIH(min), tCK = min, Input signals are changed one time during 2clks	150	140	130	120	110	mA	
Active Standby Cur- rent in Power Down Mode	IDD3P	CKE ≤ VIL(max), tCK=min	40	40	40	40	40	mA	
Active Standby Cur- rent in Non Power Down Mode	IDD3N	CKE ≥ VIH(min), /CS ≥ VIH(min), tCK=min, Input signals are changed one time during 2clks	190	180	170	160	150	mA	
Burst Mode Operating Current	IDD4	tCK ≥ tCK(min), IOL=0mA All banks active	380	360	340	320	300	mA	1
Auto Refresh Current	IDD5	tRC ≥ tRFC(min), All banks active	380	360	340	320	300	mA	1,2
Self Refresh Current	IDD6	CKE ≤ 0.2V	4	4	4	4	4	mA	
Operating Current - Four Bank Operation	IDD7	Four bank interleaving with BL=4, Refer to the following page for detailed test condition	530	510	490	470	450	mA	

Note :

1. IDD1, IDD4 and IDD5 depend on output loading and cycle rates. Specified values are measured with the output open.
2. Min. of tRFC (Auto Refresh Row Cycle Time) is shown at AC CHARACTERISTICS.

DC CHARACTERISTICS II (TA=0 to 70°C, Voltage referenced to VSS = 0V)

Parameter	Symbol	Test Condition	Speed			Unit	Note
			36	4	5		
Operating Current	IDD0	One bank; Active - Precharge; tRC=tRC(min); tCK=tCK(min); DQ,DM and DQS inputs changing twice per clock cycle; address and control inputs changing once per clock cycle	180	170	160	mA	1
Operating Current	IDD1	Burst length=2, One bank active tRC ≥ tRC(min), IOL=0mA	180	170	160	mA	1
Precharge Standby Current in Power Down Mode	IDD2P	CKE ≤ VIL(max), tCK=min	40	40	40	mA	
Precharge Standby Current in Non Power Down Mode	IDD2N	CKE ≥ VIH(min), /CS ≥ VIH(min), tCK = min, Input signals are changed one time during 2clks	100	90	80	mA	
Active Standby Current in Power Down Mode	IDD3P	CKE ≤ VIL(max), tCK=min	40	40	40	mA	
Active Standby Current in Non Power Down Mode	IDD3N	CKE ≥ VIH(min), /CS ≥ VIH(min), tCK=min, Input signals are changed one time during 2clks	140	130	120	mA	
Burst Mode Operating Current	IDD4	tCK ≥ tCK(min), IOL=0mA All banks active	280	260	240	mA	1
Auto Refresh Current	IDD5	tRC ≥ tRFC(min), All banks active	280	260	240	mA	1,2
Self Refresh Current	IDD6	CKE ≤ 0.2V	4	4	4	mA	
Operating Current - Four Bank Operation	IDD7	Four bank interleaving with BL=4, Refer to the following page for detailed test condition	430	410	390	mA	

Note :

1. IDD1, IDD4 and IDD5 depend on output loading and cycle rates. Specified values are measured with the output open.
2. Min. of tRFC (Auto Refresh Row Cycle Time) is shown at AC CHARACTERISTICS.

AC OPERATING CONDITIONS (TA=0 to 70°C, Voltage referenced to VSS = 0V)

Parameter	Symbol	Min	Max	Unit	Note
Input High (Logic 1) Voltage, DQ, DQS and DM signals	VIH(AC)	VREF + 0.45		V	
Input Low (Logic 0) Voltage, DQ, DQS and DM signals	VIL(AC)		VREF - 0.45	V	
Input Differential Voltage, CK and /CK inputs	VID(AC)	0.7	VDDQ + 0.6	V	1
Input Crossing Point Voltage, CK and /CK inputs	VIX(AC)	0.5*VDDQ-0.2	0.5*VDDQ+0.2	V	2

Note :

1. VID is the magnitude of the difference between the input level on CK and the input on /CK.
2. The value of VIX is expected to equal 0.5*VDDQ of the transmitting device and must track variations in the DC level of the same.

AC OPERATING TEST CONDITIONS (TA=0 to 70°C, Voltage referenced to VSS = 0V)

Parameter	Value	Unit
Reference Voltage	VDDQ x 0.5	V
Termination Voltage	VDDQ x 0.5	V
AC Input High Level Voltage (VIH, min)	VREF + 0.45	V
AC Input Low Level Voltage (VIL, max)	VREF - 0.45	V
Input Timing Measurement Reference Level Voltage	VREF	V
Output Timing Measurement Reference Level Voltage	VTT	V
Input Signal maximum peak swing	1.5	V
Input minimum Signal Slew Rate	1	V/ns
Termination Resistor (RT)	50	Ω
Series Resistor (RS)	25	Ω
Output Load Capacitance for Access Time Measurement (CL)	30	pF

AC Overshoot/Undershoot specifications for Address and Command pins

Parameter	200MHz Specifications
Maximum peak amplitude allowed for overshoot	1.5 V
Maximum peak amplitude allowed for undershoot	1.5 V
The area between the overshoot signal and VDD must be less than or equal to(See below Fig)	4.5 V-nS
The area between the overshoot signal and GND must be less than or equal to(See below Fig)	4.5 V-nS

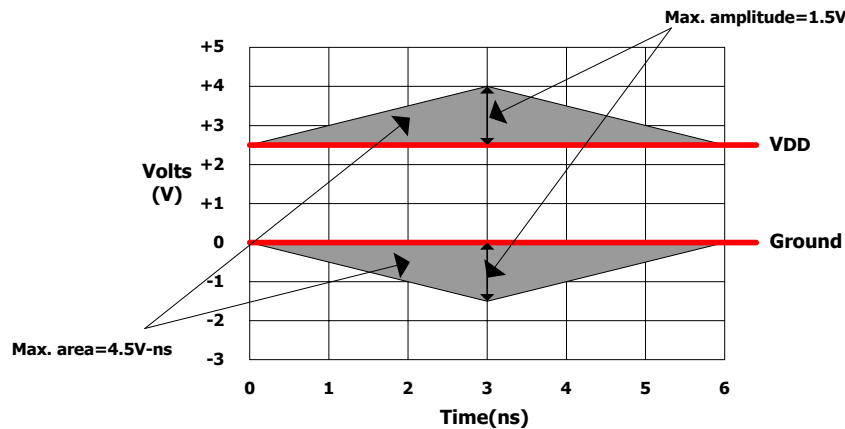
AC Overshoot/Undershoot specifications for Data, Strobe and Mask Pins

Parameter	200MHz Specifications
Maximum peak amplitude allowed for overshoot	1.2 V
Maximum peak amplitude allowed for undershoot	1.2 V
The area between the overshoot signal and VDD must be less than or equal to(See below Fig)	2.4 V-nS
The area between the overshoot signal and GND must be less than or equal to(See below Fig)	2.4 V-nS

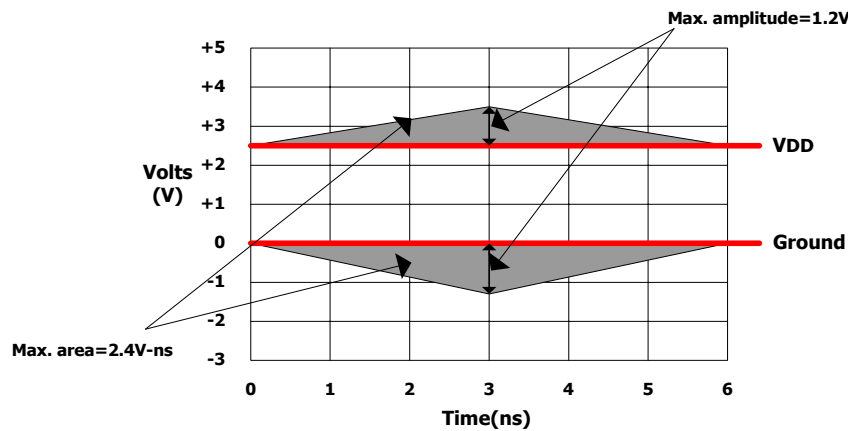

AC CHARACTERISTICS - I (AC operating conditions unless otherwise noted)

Parameter	Symbol	25		26		28		Unit	Note	
		Min	Max	Min	Max	Min	Max			
Row Cycle Time(Manual Precharge)	tRC	22	-	21	-	20	-	CK		
Row Cycle Time(Auto Precharge)	tRC_APCG	24	-	23	-	22	-			
Auto Refresh Row Cycle Time	tRFC	26	-	25	-	24	-	CK		
Row Active Time	tRAS	16	100K	15	100K	14	100K	CK		
Row Address to Column Address Delay for Read	tRCDRD	6	-	6	-	6	-	CK		
Row Address to Column Address Delay for Write	tRCDWR	4	-	4	-	4	-	CK		
Row Active to Row Active Delay	tRRD	4	-	4	-	4	-	CK		
Column Address to Column Address Delay	tCCD	2	-	2	-	2	-	CK		
Row Precharge Time	tRP	6	-	6	-	6	-	CK		
Write Recovery Time	tWR	4	-	4	-	4	-	CK		
Last Data-In to Read Command	tDRL	2	-	2	-	2	-	CK		
Auto Precharge Write Recovery + Precharge Time	tDAL	10	-	10	-	10	-	CK		
System Clock Cycle Time	CL=5	tCK	2.5	6	2.6	6	-	-	ns	
	CL=4		-	-	-	-	2.8	6		
Clock High Level Width	tCH	0.45	0.55	0.45	0.55	0.45	0.55	CK		
Clock Low Level Width	tCL	0.45	0.55	0.45	0.55	0.45	0.55	CK		
Data-Out edge to Clock edge Skew	tAC	-0.55	0.55	-0.6	0.6	-0.6	0.6	ns		
DQS-Out edge to Clock edge Skew	tDQSK	-0.55	0.55	-0.6	0.6	-0.6	0.6	ns		
DQS-Out edge to Data-Out edge Skew	tDQSQ	-	0.35	-	0.35	-	0.35	ns		
Data-Out hold time from DQS	tQH	tHPmin -tQHS	-	tHPmin -tQHS	-	tHPmin -tQHS	-	ns	1,6	
Clock Half Period	tHP	tCH/L min	-	tCH/L min	-	tCH/L min	-	ns	1,5	
Data Hold Skew Factor	tQHS	-	0.35	-	0.35	-	0.35	ns	6	
Input Setup Time	tIS	0.75	-	0.75	-	0.75	-	ns	2	
Input Hold Time	tIH	0.75	-	0.75	-	0.75	-	ns	2	
Write DQS High Level Width	tDQSH	0.4	0.6	0.4	0.6	0.4	0.6	CK		
Write DQS Low Level Width	tDQSL	0.4	0.6	0.4	0.6	0.4	0.6	CK		
Clock to First Rising edge of DQS-In	tDQSS	0.85	1.15	0.85	1.15	0.85	1.15	CK		
Data-In Setup Time to DQS-In (DQ & DM)	tDS	0.35	-	0.35	-	0.35	-	ns	3	
Data-In Hold Time to DQS-In (DQ & DM)	tDH	0.35	-	0.35	-	0.35	-	ns	3	

Parameter	Symbol	25		26		28		Unit	Note
		Min	Max	Min	Max	Min	Max		
DQS falling edge to CK setup time	tDSS	3.0	-	3.0	-	3.0	-	CK	
DQS falling edge hold time from CK	tDSH	3.0	-	3.0	-	3.0	-	CK	
Write DQS Preamble Setup Time	tWPRES	0	-	0	-	0	-	ns	
Write DQS Preamble Hold Time	tWPREH	0.35	-	0.35	-	0.35	-	CK	
Write DQS Postamble Time	tWPST	0.4	0.6	0.4	0.6	0.4	0.6	CK	
Mode Register Set Delay	tMRD	10	-	10	-	10	-	ns	
Exit Self Refresh to Any Execute Command	tXSC	200	-	200	-	200	-	CK	4
Power Down Exit Time	tPDEX	2tCK + tIS	-	2tCK + tIS	-	2tCK + tIS	-	CK	
Average Periodic Refresh Interval	tREFI	-	7.8	-	7.8	-	7.8	us	

Note :

1. This calculation accounts for tDQSQ(max), the pulse width distortion of on-chip circuit and jitter.
2. Data sampled at the rising edges of the clock : A0~A11, BA0~BA1, CKE, /CS, /RAS, /CAS, /WE.
3. Data latched at both rising and falling edges of Data Strob(UDQS,LDQS) : DQ, LDM,UDM.
4. Minimum of 200 cycles of stable input clocks after Self Refresh Exit command, where CKE is held high, is required to complete Self Refresh Exit and lock the internal DLL circuit of DDR SDRAM.
5. Min (tCL, tCH) refers to the smaller of the actual clock low time and the actual clock high time as provided to the device (i.e. this value can be greater than the minimum specification limits for tCL and tCH).
6. tHP = minimum half clock period for any given cycle and is defined by clock high or clock low (tCH, tCL).
tQHS consists of tDQSQmax, the pulse width distortion of on-chip clock circuits, data pin to pin skew and output pattern effects, and p-channel to n-channel variation of the output drivers.
7. DQS, DM and DQ input slew rate is specified to prevent double clocking of data and preserve setup and hold times. Signal transitions through the DC region must be monotonic.

AC CHARACTERISTICS - I (AC operating conditions unless otherwise noted)

Parameter	Symbol	30		33		36		Unit	Note
		Min	Max	Min	Max	Min	Max		
Row Cycle Time(Manual Precharge)	tRC	19	-	18	-	16	-	CK	
Row Cycle Time(Auto Precharge)	tRC_APCG	21	-	20	-	18	-		
Auto Refresh Row Cycle Time	tRFC	23	-	22	-	20	-	CK	
Row Active Time	tRAS	13	100K	12	100K	11	100K	CK	
Row Address to Column Address Delay for Read	tRCDRD	6	-	6	-	5	-	CK	
Row Address to Column Address Delay for Write	tRCDWR	4	-	4	-	3	-	CK	
Row Active to Row Active Delay	tRRD	4	-	4	-	3	-	CK	
Column Address to Column Address Delay	tCCD	2	-	1	-	1	-	CK	
Row Precharge Time	tRP	6	-	6	-	5	-	CK	
Write Recovery Time	tWR	4	-	4	-	3	-	CK	
Last Data-In to Read Command	tDRL	2	-	2	-	2	-	CK	
Auto Precharge Write Recovery + Precharge Time	tDAL	10	-	10	-	8	-	CK	
System Clock Cycle Time	CL=4 tCK	3	6	3.3	6	3.6	10	ns	
Clock High Level Width	tCH	0.45	0.55	0.45	0.55	0.45	0.55	CK	
Clock Low Level Width	tCL	0.45	0.55	0.45	0.55	0.45	0.55	CK	
Data-Out edge to Clock edge Skew	tAC	-0.6	0.6	-0.6	0.6	-0.6	0.6	ns	
DQS-Out edge to Clock edge Skew	tDQSCK	-0.6	0.6	-0.6	0.6	-0.6	0.6	ns	
DQS-Out edge to Data-Out edge Skew	tDQSQ	-	0.35	-	0.35	-	0.35	ns	
Data-Out hold time from DQS	tQH	tHPmin -tQHS	-	tHPmin -tQHS	-	tHPmin -tQHS	-	ns	1,6
Clock Half Period	tHP	tCH/L min	-	tCH/L min	-	tCH/L min	-	ns	1,5
Data Hold Skew Factor	tQHS	-	0.35	-	0.35	-	0.4	ns	6
Input Setup Time	tIS	0.75	-	0.75	-	0.75	-	ns	2
Input Hold Time	tIH	0.75	-	0.75	-	0.75	-	ns	2
Write DQS High Level Width	tDQSH	0.4	0.6	0.4	0.6	0.4	0.6	CK	
Write DQS Low Level Width	tDQSL	0.4	0.6	0.4	0.6	0.4	0.6	CK	
Clock to First Rising edge of DQS-In	tDQSS	0.85	1.15	0.85	1.15	0.85	1.15	CK	
Data-In Setup Time to DQS-In (DQ & DM)	tDS	0.35	-	0.35	-	0.4	-	ns	3
Data-In Hold Time to DQS-In (DQ & DM)	tDH	0.35	-	0.35	-	0.4	-	ns	3

Parameter	Symbol	30		33		36		Unit	Note
		Min	Max	Min	Max	Min	Max		
DQS falling edge to CK setup time	tDSS	0.3	-	0.3	-	0.3	-	CK	
DQS falling edge hold time from CK	tDSH	0.3	-	0.3	-	0.3	-	CK	
Read DQS Preamble Time	tRPRE	0.9	1.1	0.9	1.1	0.9	1.1	CK	
Read DQS Postamble Time	tRPST	0.4	0.6	0.4	0.6	0.4	0.6	CK	
Write DQS Preamble Setup Time	tWPRES	0	-	0	-	0	-	ns	
Write DQS Preamble Hold Time	tWPREH	0.35	-	0.35	-	0.35	-	CK	
Write DQS Postamble Time	tWPST	0.4	0.6	0.4	0.6	0.4	0.6	CK	
Mode Register Set Delay	tMRD	10	-	10	-	10	-	ns	
Exit Self Refresh to Any Execute Command	tXSC	200	-	200	-	200	-	CK	4
Power Down Exit Time	tPDEX	2tCK + tIS	-	2tCK + tIS	-	2tCK + tIS	-	CK	
Average Periodic Refresh Interval	tREFI	-	7.8	-	7.8	-	7.8	us	

Note :

1. This calculation accounts for tDQSQ(max), the pulse width distortion of on-chip circuit and jitter.
2. Data sampled at the rising edges of the clock : A0~A11, BA0~BA1, CKE, /CS, /RAS, /CAS, /WE.
3. Data latched at both rising and falling edges of Data Strobes(UDQS,LDQS) : DQ, LDM,UDM.
4. Minimum of 200 cycles of stable input clocks after Self Refresh Exit command, where CKE is held high, is required to complete Self Refresh Exit and lock the internal DLL circuit of DDR SDRAM.
5. Min (tCL, tCH) refers to the smaller of the actual clock low time and the actual clock high time as provided to the device (i.e. this value can be greater than the minimum specification limits for tCL and tCH).
6. tHP = minimum half clock period for any given cycle and is defined by clock high or clock low (tCH, tCL).
tQHS consists of tDQSQmax, the pulse width distortion of on-chip clock circuits, data pin to pin skew and output pattern effects, and p-channel to n-channel variation of the output drivers.
7. DQS, DM and DQ input slew rate is specified to prevent double clocking of data and preserve setup and hold times. Signal transitions through the DC region must be monotonic.

AC CHARACTERISTICS - I (Continued)

Parameter	Symbol	4		5		Unit	Note
		Min	Max	Min	Max		
Row Cycle Time(Manual Precharge)	tRC	15	-	12	-	CK	
Row Cycle Time(Auto Precharge)	tRC_APCG	17	-	13	-		
Auto Refresh Row Cycle Time	tRFC	18	-	14	-	CK	
Row Active Time	tRAS	10	100K	8	100K	CK	
Row Address to Column Address Delay for Read	tRCDRD	5	-	4	-	CK	
Row Address to Column Address Delay for Write	tRCDWR	3	-	2	-	CK	
Row Active to Row Active Delay	tRRD	3	-	2	-	CK	
Column Address to Column Address Delay	tCCD	1	-	1	-	CK	
Row Precharge Time	tRP	5	-	4	-	CK	
Write Recovery Time	tWR	3	-	3	-	CK	
Last Data-In to Read Command	tDRL	2	-	2	-	CK	
Auto Precharge Write Recovery + Precharge Time	tDAL	8	-	7	-	CK	
System Clock Cycle Time	tCK	CL=4	4	10	-	-	ns
		CL=3	-	-	5	10	
Clock High Level Width	tCH	0.45	0.55	0.45	0.55	CK	
Clock Low Level Width	tCL	0.45	0.55	0.45	0.55	CK	
Data-Out edge to Clock edge Skew	tAC	-0.6	0.6	-0.65	0.65	ns	
DQS-Out edge to Clock edge Skew	tDQSK	-0.6	0.6	-0.55	0.55	ns	
DQS-Out edge to Data-Out edge Skew	tDQSQ	-	0.4	-	0.4	ns	
Data-Out hold time from DQS	tQH	tHPmin -tQHS	-	tHPmin -tQHS	-	ns	1,6
Clock Half Period	tHP	tCH/L min	-	tCH/L min	-	ns	1,5
Data Hold Skew Factor	tQHS	-	0.4	-	0.45	ns	6
Input Setup Time	tIS	0.75	-	0.6	-	ns	2
Input Hold Time	tIH	0.75	-	0.6	-	ns	2
Write DQS High Level Width	tDQSH	0.4	0.6	0.4	0.6	CK	
Write DQS Low Level Width	tDQSL	0.4	0.6	0.4	0.6	CK	
Clock to First Rising edge of DQS-In	tDQSS	0.85	1.15	0.72	1.28	CK	

Parameter	Symbol	4		5		Unit	Note
		Min	Max	Min	Max		
Data-In Setup Time to DQS-In (DQ & DM)	tDS	0.4	-	0.4	-	ns	3
Data-In Hold Time to DQS-In (DQ & DM)	tDH	0.4	-	0.4	-	ns	3
DQS falling edge to CK setup time	tDSS	0.3	-	0.3	-	CK	
DQS falling edge hold time from CK	tDSH	0.3	-	0.3	-	CK	
Read DQS Preamble Time	tRPRE	0.9	1.1	0.9	1.1	CK	
Read DQS Postamble Time	tRPST	0.4	0.6	0.4	0.6	CK	
Write DQS Preamble Setup Time	tWPRES	0	-	0	-	ns	
Write DQS Preamble Hold Time	tWPREH	0.35	-	0.25	-	CK	
Write DQS Postamble Time	tWPST	0.4	0.6	0.4	0.6	CK	
Mode Register Set Delay	tMRD	10	-	10	-	ns	
Exit Self Refresh to Any Execute Command	tXSC	200	-	200	-	CK	4
Power Down Exit Time	tPDEX	2tCK + tIS	-	2tCK + tIS	-	CK	
Average Periodic Refresh Interval	tREFI	-	7.8	-	7.8	us	

Note :

1. This calculation accounts for tDQSQ(max), the pulse width distortion of on-chip circuit and jitter.
2. Data sampled at the rising edges of the clock : A0~A11, BA0~BA1, CKE, /CS, /RAS, /CAS, /WE.
3. Data latched at both rising and falling edges of Data Strobes(UDQS,LDQS) : DQ, UDM,LDM.
4. Minimum of 200 cycles of stable input clocks after Self Refresh Exit command, where CKE is held high, is required to complete Self Refresh Exit and lock the internal DLL circuit of DDR SDRAM.
5. Min (tCL, tCH) refers to the smaller of the actual clock low time and the actual clock high time as provided to the device (i.e. this value can be greater than the minimum specification limits for tCL and tCH).
6. tHP = minimum half clock period for any given cycle and is defined by clock high or clock low (tCH, tCL).
tQHS consists of tDQSQmax, the pulse width distortion of on-chip clock circuits, data pin to pin skew and output pattern effects, and p-channel to n-channel variation of the output drivers.
7. DQS, DM and DQ input slew rate is specified to prevent double clocking of data and preserve setup and hold times. Signal transitions through the DC region must be monotonic.

AC CHARACTERISTICS - II

Frequency	CL	tRC	tRC_APCG	tRFC	tRAS	tRCDRD	tRCDWR	tRP	tDAL	Unit
400MHz (2.5ns)	5	22	24	26	16	6	4	6	10	tCK
375MHz (2.6ns)	5	21	23	25	15	6	4	6	10	tCK
350MHz (2.8ns)	4	20	22	24	14	6	4	6	10	tCK
333MHz (3.0ns)	4	19	21	23	13	6	4	6	10	tCK
300MHz (3.3ns)	4	18	20	22	12	6	4	6	10	tCK
275MHz (3.6ns)	4	16	18	20	11	5	3	5	8	tCK
250MHz (4.0ns)	4	15	17	18	10	5	3	5	8	tCK
200MHz (5.0ns)	3	12	13	14	8	4	2	4	7	tCK

CAPACITANCE ($T_A=25^{\circ}\text{C}$, $f=1\text{MHz}$)

Parameter	Pin	Symbol	Min	Max	Unit
Input Clock Capacitance	CK, /CK	CCK	2	3	pF
Input Capacitance	All other input-only pins	CIN	2	3	pF
Input / Output Capacitance	DQ, DQS, DM	CIO	4	5	pF

Note :

1. VDD = min. to max., VDDQ = 2.375V to 2.625V, V_{ODC} = VDDQ/2, V_{Opeak-to-peak} = 0.2V
2. Pins not under test are tied to GND.
3. These values are guaranteed by design and are tested on a sample basis only.

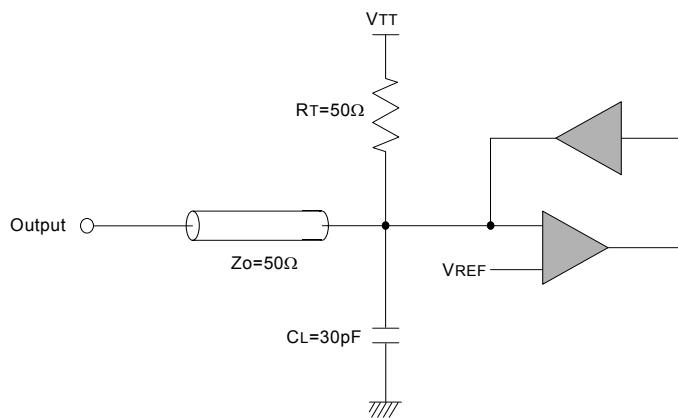
OUTPUT LOAD CIRCUIT

PACKAGE INFORMATION

400mil 66pin Thin Small Outline Package

