

HD74HC74

Dual D-type Flip-Flops (with Preset and Clear)

HITACHI



Description

The flip-flop has independent data, preset, clear, and clock inputs and Q and \bar{Q} outputs. The logic level present at the data input is transferred to the output during the positive going transition to the clock pulse. Preset and clear are independent of the clock and accomplished by a low level at the appropriate input.

Features

- High Speed Operation: t_{pd} (Clock to Q or \bar{Q}) = 14 ns typ ($C_L = 50$ pF)
- High Output Current: Fanout of 10 LSTTL Loads
- Wide Operating Voltage: $V_{CC} = 2$ to 6 V
- Low Input Current: 1 μ A max
- Low Quiescent Supply Current: I_{CC} (static) = 2 μ A max ($T_a = 25^\circ\text{C}$)

Function Table

Inputs				Outputs	
Preset	Clear	Clock	Data	Q	\bar{Q}
L	H	X	X	H	L
H	L	X	X	L	H
L	L	X	X	H* ¹	H* ¹
H	H		H	H	L
H	H		L	L	H
H	H	L	X	no change	no change
H	H	H	X	no change	no change
H	H		X	no change	no change

Note: 1. Q and \bar{Q} will remain HIGH as long as Preset and Clear are Low, but Q and \bar{Q} are unpredictable, if Preset and Clear go HIGH simultaneously.

HD74HC74

Pin Arrangement

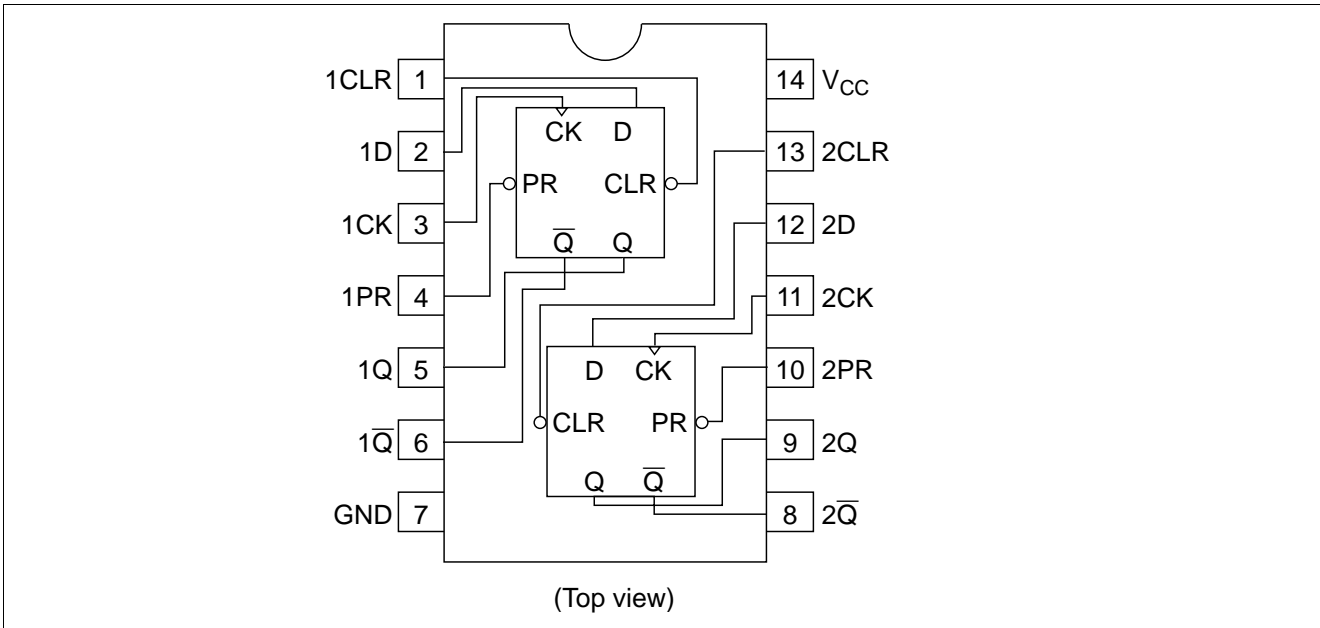

Logic Diagram (1/2)

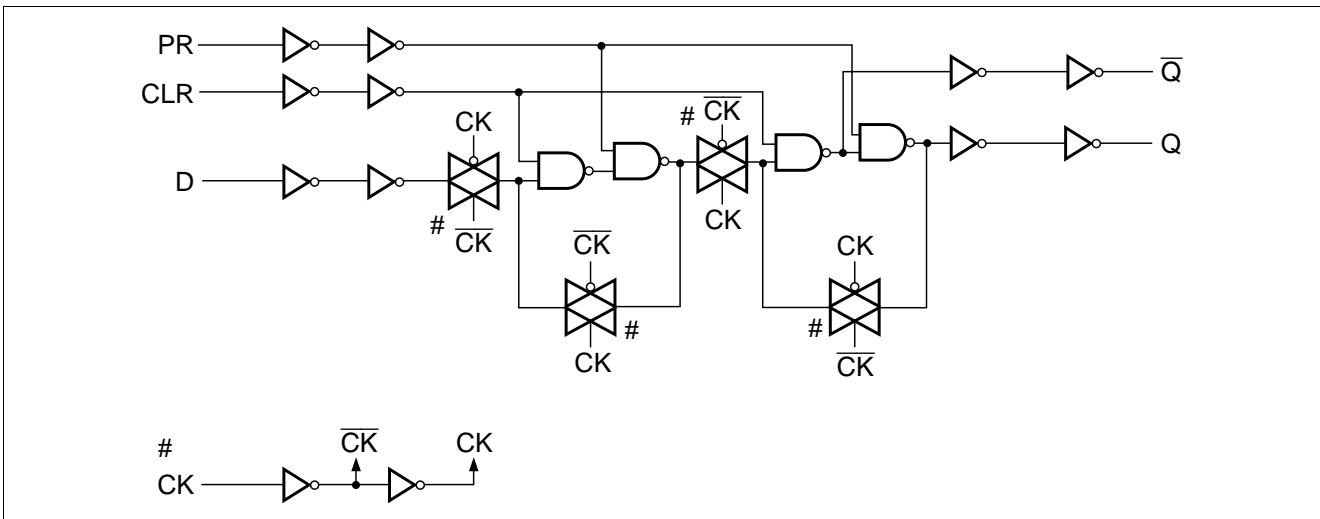

HITACHI

DC Characteristics

Item	Symbol	V _{CC} (V)	Ta = 25°C			Ta = -40 to +85°C		Unit	Test Conditions	
			Min	Typ	Max	Min	Max			
Input voltage	V _{IH}	2.0	1.5	—	—	1.5	—	V		
		4.5	3.15	—	—	3.15	—			
		6.0	4.2	—	—	4.2	—			
	V _{IL}	2.0	—	—	0.5	—	0.5			V
		4.5	—	—	1.35	—	1.35			
		6.0	—	—	1.8	—	1.8			
Output voltage	V _{OH}	2.0	1.9	2.0	—	1.9	—	V	Vin = V _{IH} or V _{IL} I _{OH} = -20 μA	
		4.5	4.4	4.5	—	4.4	—			
		6.0	5.9	6.0	—	5.9	—			
		4.5	4.18	—	—	4.13	—			I _{OH} = -4 mA
		6.0	5.68	—	—	5.63	—			I _{OH} = -5.2 mA
	V _{OL}	2.0	—	0.0	0.1	—	0.1	V	Vin = V _{IH} or V _{IL} I _{OL} = 20 μA	
		4.5	—	0.0	0.1	—	0.1			
		6.0	—	0.0	0.1	—	0.1			
		4.5	—	—	0.26	—	0.33			I _{OL} = 4 mA
		6.0	—	—	0.26	—	0.33			I _{OL} = 5.2 mA
Input current	I _{in}	6.0	—	—	±0.1	—	±1.0	μA	Vin = V _{CC} or GND	
Quiescent supply current	I _{CC}	6.0	—	—	2.0	—	20	μA	Vin = V _{CC} or GND, I _{out} = 0 μA	

HD74HC74

AC Characteristics ($C_L = 50$ pF, Input $t_r = t_f = 6$ ns)

Item	Symbol	V_{CC} (V)	Ta = 25°C			Ta = -40 to +85°C		Unit	Test Conditions
			Min	Typ	Max	Min	Max		
Maximum clock frequency	f_{max}	2.0	—	—	5	—	4	MHz	
		4.5	—	35	25	—	20		
		6.0	—	—	29	—	24		
Propagation delay time	t_{PLH}	2.0	—	—	160	—	200	ns	Clock to Q or \bar{Q}
		4.5	—	14	32	—	40		
		6.0	—	—	27	—	34		
	t_{PHL}	2.0	—	—	160	—	200		Preset or Clear to Q or \bar{Q}
		4.5	—	13	32	—	40		
		6.0	—	—	27	—	34		
Setup time	t_{su}	2.0	100	—	—	125	—	ns	Data to Clock
		4.5	20	1	—	25	—		
		6.0	17	—	—	21	—		
Hold time	t_h	2.0	5	—	—	5	—	ns	Clock to Data
		4.5	5	0	—	5	—		
		6.0	5	—	—	5	—		
Removal time	t_{rem}	2.0	25	—	—	31	—	ns	Preset, Clear to Clock
		4.5	5	-5	—	6	—		
		6.0	4	—	—	5	—		
Pulse width	t_w	2.0	80	—	—	100	—	ns	Clock, Preset, Clear
		4.5	16	8	—	20	—		
		6.0	14	—	—	17	—		
Output rise/fall time	t_{TLH}	2.0	—	—	75	—	95	ns	
		4.5	—	5	15	—	19		
	t_{THL}	6.0	—	—	13	—	16		
Input Capacitance	C_{in}	—	—	5	10	—	10	pF	

Unit: mm

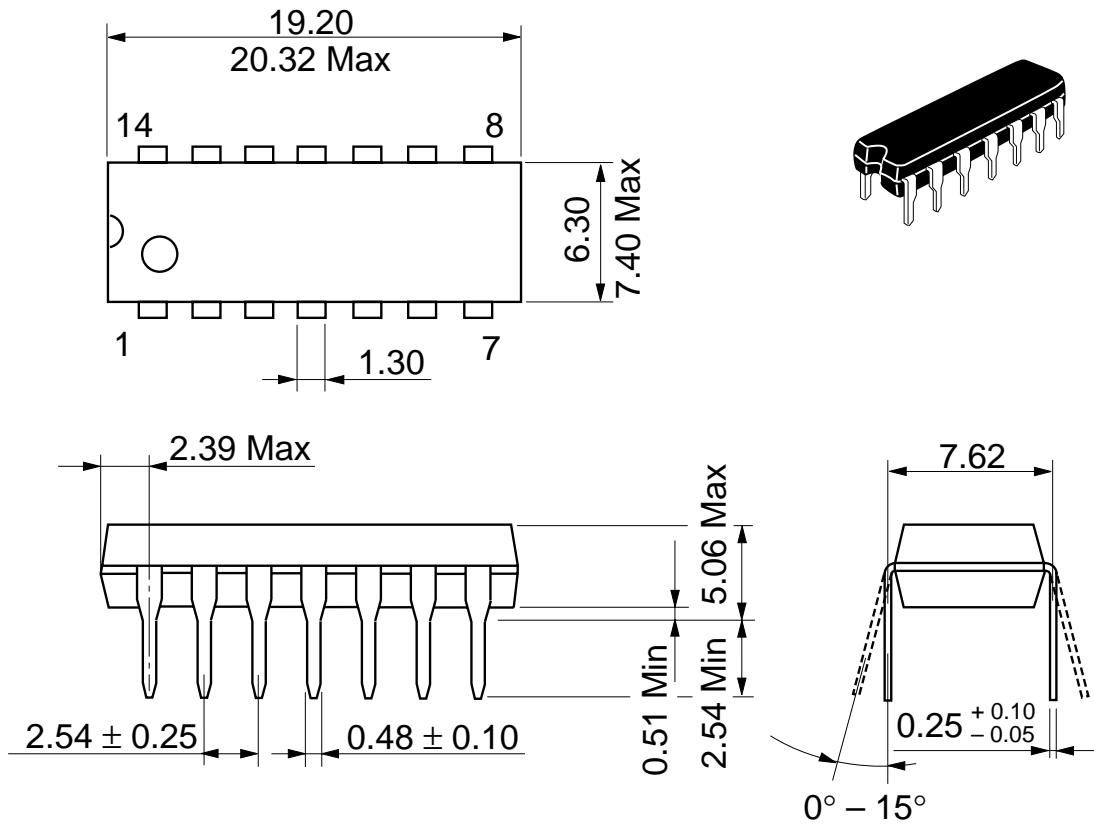

Hitachi Code	DP-14
JEDEC	Conforms
EIAJ	Conforms
Weight (reference value)	0.97 g

Unit: mm

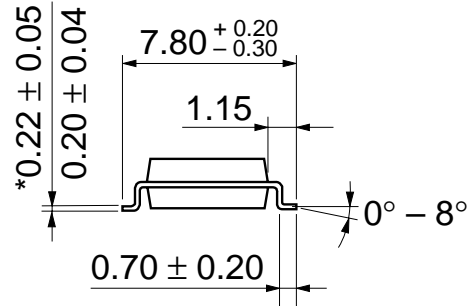
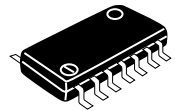
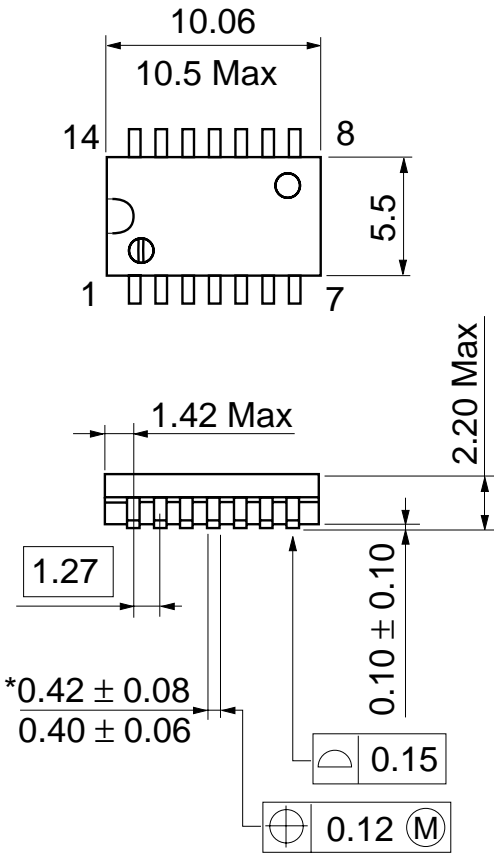

*Dimension including the plating thickness
Base material dimension

Hitachi Code	FP-14DA
JEDEC	—
EIAJ	Conforms
Weight (reference value)	0.23 g

Unit: mm

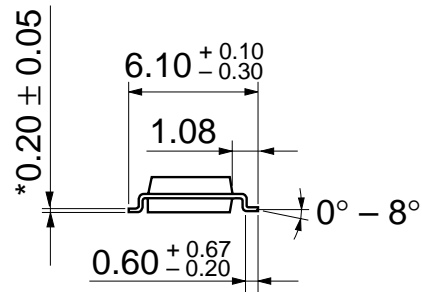
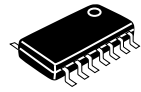
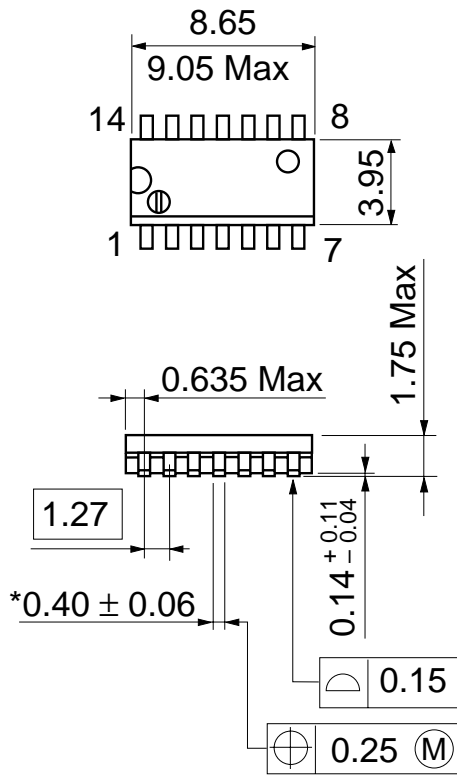

Hitachi Code	FP-14DN
JEDEC	Conforms
EIAJ	Conforms
Weight (reference value)	0.13 g

*Pd plating

Unit: mm

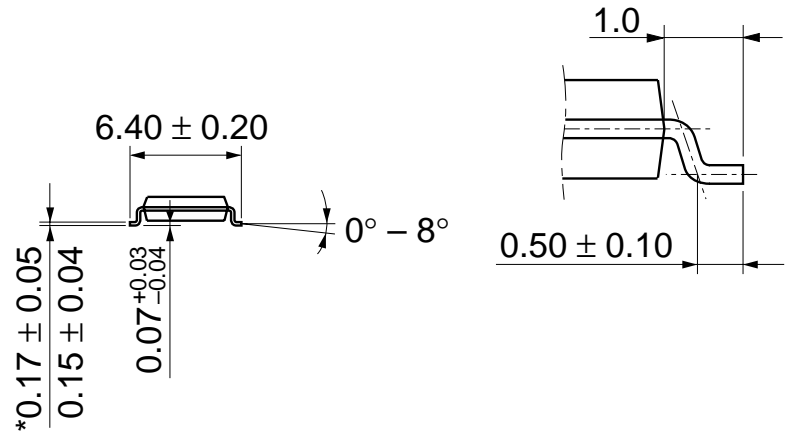
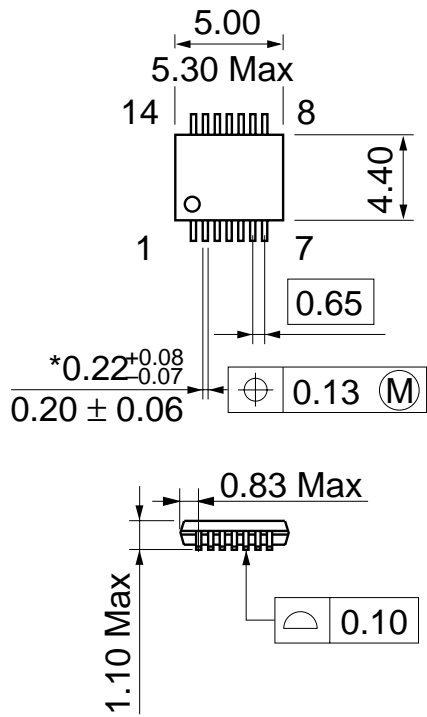

Hitachi Code	TTP-14D
JEDEC	—
EIAJ	—
Weight (reference value)	0.05 g

*Dimension including the plating thickness
 Base material dimension

Cautions

1. Hitachi neither warrants nor grants licenses of any rights of Hitachi's or any third party's patent, copyright, trademark, or other intellectual property rights for information contained in this document. Hitachi bears no responsibility for problems that may arise with third party's rights, including intellectual property rights, in connection with use of the information contained in this document.
2. Products and product specifications may be subject to change without notice. Confirm that you have received the latest product standards or specifications before final design, purchase or use.
3. Hitachi makes every attempt to ensure that its products are of high quality and reliability. However, contact Hitachi's sales office before using the product in an application that demands especially high quality and reliability or where its failure or malfunction may directly threaten human life or cause risk of bodily injury, such as aerospace, aeronautics, nuclear power, combustion control, transportation, traffic, safety equipment or medical equipment for life support.
4. Design your application so that the product is used within the ranges guaranteed by Hitachi particularly for maximum rating, operating supply voltage range, heat radiation characteristics, installation conditions and other characteristics. Hitachi bears no responsibility for failure or damage when used beyond the guaranteed ranges. Even within the guaranteed ranges, consider normally foreseeable failure rates or failure modes in semiconductor devices and employ systemic measures such as fail-safes, so that the equipment incorporating Hitachi product does not cause bodily injury, fire or other consequential damage due to operation of the Hitachi product.
5. This product is not designed to be radiation resistant.
6. No one is permitted to reproduce or duplicate, in any form, the whole or part of this document without written approval from Hitachi.
7. Contact Hitachi's sales office for any questions regarding this document or Hitachi semiconductor products.

HITACHI

Hitachi, Ltd.

Semiconductor & Integrated Circuits.

Nippon Bldg., 2-6-2, Ohte-machi, Chiyoda-ku, Tokyo 100-0004, Japan

Tel: Tokyo (03) 3270-2111 Fax: (03) 3270-5109

URL NorthAmerica : <http://semiconductor.hitachi.com/>
 Europe : <http://www.hitachi-eu.com/hel/ecg>
 Asia (Singapore) : <http://www.has.hitachi.com.sg/grp3/sicd/index.htm>
 Asia (Taiwan) : http://www.hitachi.com.tw/E/Product/SICD_Frame.htm
 Asia (HongKong) : <http://www.hitachi.com.hk/eng/bo/grp3/index.htm>
 Japan : <http://www.hitachi.co.jp/Sicd/indx.htm>

For further information write to:

Hitachi Semiconductor
(America) Inc.
179 East Tasman Drive,
San Jose, CA 95134
Tel: <1> (408) 433-1990
Fax: <1> (408) 433-0223

Hitachi Europe GmbH
Electronic components Group
Dornacher StraÙe 3
D-85622 Feldkirchen, Munich
Germany
Tel: <49> (89) 9 9180-0
Fax: <49> (89) 9 29 30 00

Hitachi Europe Ltd.
Electronic Components Group.
Whitebrook Park
Lower Cookham Road
Maidenhead
Berkshire SL6 8YA, United Kingdom
Tel: <44> (1628) 585000
Fax: <44> (1628) 778322

Hitachi Asia Pte. Ltd.
16 Collyer Quay #20-00
Hitachi Tower
Singapore 049318
Tel: 535-2100
Fax: 535-1533

Hitachi Asia Ltd.
Taipei Branch Office
3F, Hung Kuo Building, No.167,
Tun-Hwa North Road, Taipei (105)
Tel: <886> (2) 2718-3666
Fax: <886> (2) 2718-8180

Hitachi Asia (Hong Kong) Ltd.
Group III (Electronic Components)
7/F., North Tower, World Finance Centre,
Harbour City, Canton Road, Tsim Sha Tsui,
Kowloon, Hong Kong
Tel: <852> (2) 735 9218
Fax: <852> (2) 730 0281
Telex: 40815 HITEC HX

Copyright ' Hitachi, Ltd., 1999. All rights reserved. Printed in Japan.

HITACHI