

BIPOLAR ANALOG INTEGRATED CIRCUIT

μ PC1658G

LOW NOISE, HIGH FREQUENCY Si MMIC AMPLIFIER

DESCRIPTION

The μ PC1658G is a silicon monolithic integrated circuit designed as amplifier for high frequency system applications. Bandwidth and output power level can be determined according to external resistor constants of negative feedback and final stage collector. This IC is available in 8-pin plastic SOP.

This IC is manufactured using NEC's 10 GHz fr NESAT™ II silicon bipolar process. This process uses silicon nitride passivation film and gold electrodes. These materials can protect chip surface from external pollution and prevent corrosion/migration. Thus, this IC has excellent performance, uniformity and reliability.

FEATURES

- Low noise figure : $NF \leq 3$ dB
- Due to the external negative feedback circuit, the power gain can be adjustable by selecting appropriate resistance constants.
 - : $G_P \geq 40$ dB @ Without negative feedback resistor
 - : $G_P \geq 18$ dB @ With negative feedback resistor
- Wideband response : $f_{3dB} = 1.0$ GHz @ $G_P = 18$ dB
- External resistor can vary the collector current of the final transistor in the IC to adjust the saturated output level.

APPLICATIONS

- IF buffer amplifier of high frequency system
- Measurement equipment

ORDERING INFORMATION

Part Number	Package	Marking	Supplying Form
μ PC1658G-E1	8-pin plastic SOP (225 mil)	1658	Embossed tape 12 mm wide. 1 pin is tape pull-out direction. Qty 2.5 kp/reel.

Remark To order evaluation samples, please contact your local NEC sales office.
(Part number for sample order: μ PC1658G)

Caution TO-99 CAN package (μ PC1658A) and 8-pin plastic DIP package (μ PC1658C) products are discontinued.

Caution Electro-static sensitive devices

The information in this document is subject to change without notice. Before using this document, please confirm that this is the latest version.
Not all devices/types available in every country. Please check with local NEC representative for availability and additional information.

PIN CONNECTIONS

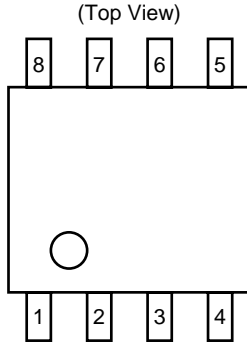

Pin No.	Pin Name
1	GND
2	Test Point
3	Output
4	V _{cc}
5	Test Point
6	Input
7	Bypass
8	Bypass

PIN EXPLANATION

Pin No.	Pin Name	Function and Applications	Internal Equivalent Circuit
1	GND	Ground pin. This pin should be connected to system ground with minimum inductance. Ground pattern on the board should be formed as possible. All the ground pins must be connected together with wide ground pattern to decrease impedance difference.	
2	Test Point	Test Point pin. The collector current of Q ₂ and Q ₃ can be varied by connecting an appropriate external resistance between this pin and GND or by shorting this pin to GND. By increasing the collector current of Q ₃ , the output level improves and the IC can operate as a low-distortion amplifier.	
3	Output	Signal output pin. This pin must be coupled to signal source with capacitor for DC cut.	
4	V _{cc}	Power supply pin. This pin should be externally equipped with bypass capacitor to minimize its impedance.	
5	Test Point	By connecting this pin to the power supply through an appropriate external resistance or by shorting this pin directly to the power supply, the gain can be adjustable (when using pin 2, short the pin 5 to the power supply).	
6	Input	Signal input pin. Through negative feedback from output pin with an external circuit, the IC operates as a wideband amplifier.	
7	Bypass	Emitter bypass pins of Q ₁ . Bypass these pins to GND with a capacitor.	
8	Bypass	Emitter bypass pins of Q ₁ . Bypass these pins to GND with a capacitor.	

ABSOLUTE MAXIMUM RATINGS

Parameter	Symbol	Conditions	Rating	Unit
Supply Voltage	V _{CC}	T _A = +25 °C	12	V
Output Transistor Current	I _{O3}	T _A = +25 °C	40	mA
Power Dissipation	P _D	Mounted on double copper clad 50 × 50 × 1.6 mm epoxy glass PWB (T _A = +70 °C)	280	mW
Operating Ambient Temperature	T _A		-40 to +75	°C
Storage Temperature	T _{stg}		-55 to +150	°C

ELECTRICAL CHARACTERISTICS (T_A = +25 °C, V_{CC} = 10.0 V, Z_S = Z_L = 50 Ω, Test circuit 1)

Parameter	Symbol	Conditions	MIN.	TYP.	MAX.	Unit
Circuit Current	I _{CC}	No signal	9	-	18	mA
Power Gain 1	G _{P1}	f = 10 MHz	37	41	45	dB
Power Gain 2	G _{P2}	f = 100 MHz	28	31	34	dB
Power Gain 3	G _{P3}	f = 500 MHz	14	17	20	dB
Noise Figure 1	NF ₁	f = 100 MHz	-	1.5	2.5	dB
Noise Figure 2	NF ₂	f = 500 MHz	-	2.0	3.0	dB

TEST SET-UP

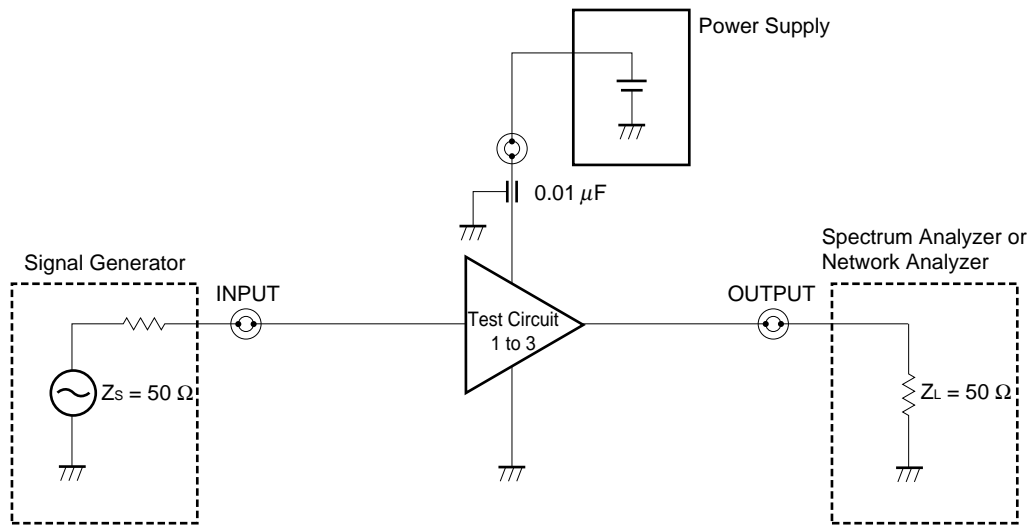

TEST CIRCUITS

TEST CIRCUIT 1 (Low-noise amplifier)

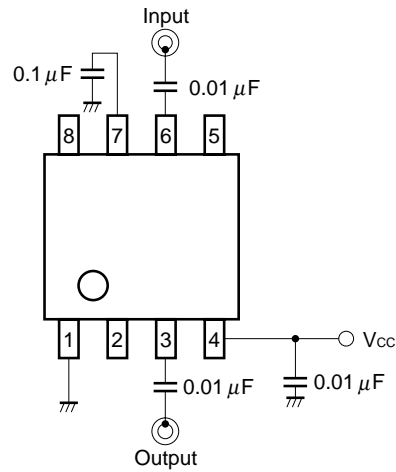

TEST CIRCUIT 2 (Wideband low-noise amplifier)

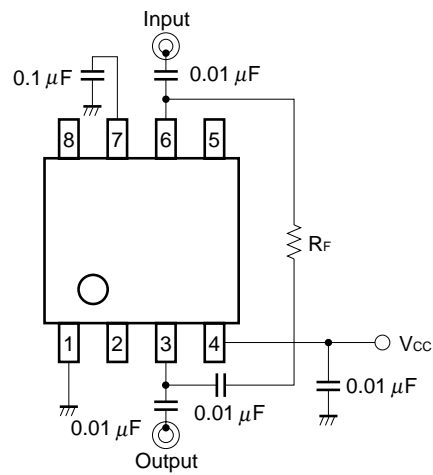

TEST CIRCUIT 3 (Wideband low-noise amplifier with improved output level)

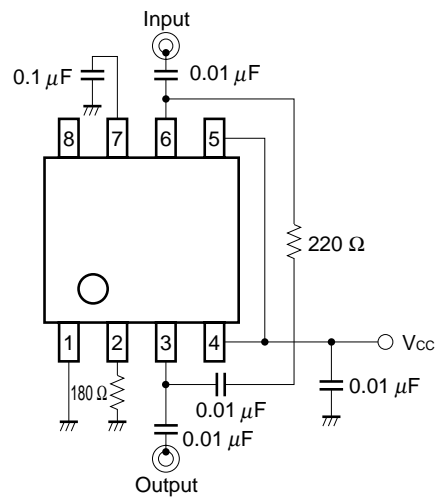
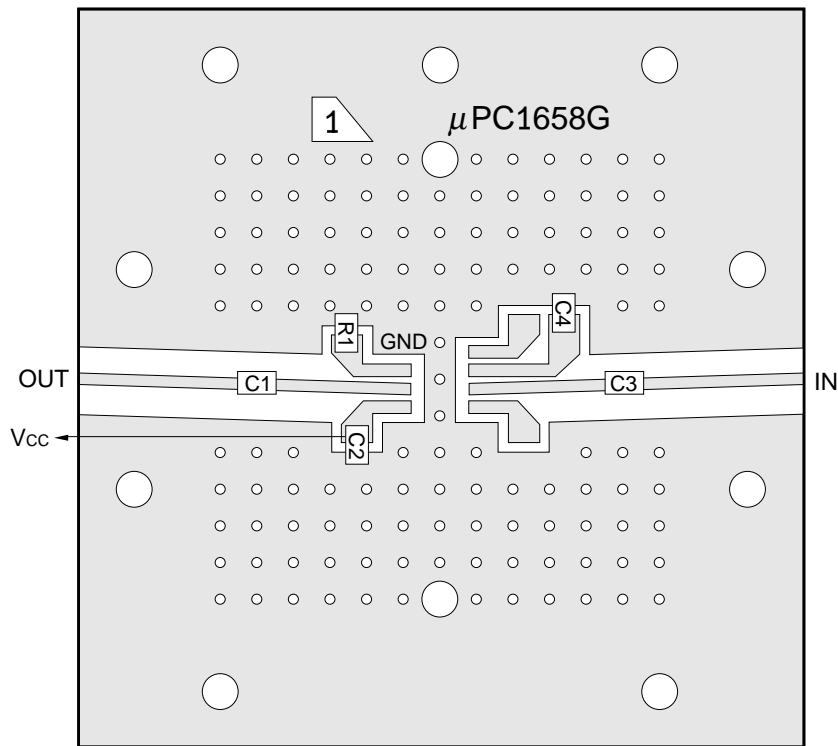

ILLUSTRATION OF THE TEST CIRCUIT ASSEMBLED ON EVALUATION BOARD



- Notes**
1. 50 × 50 × 0.4 mm double sided copper clad polyimide board.
 2. Back side: GND pattern
 3. Solder plated on pattern
 4. ○ ○ : Through holes

COMPONENT LIST

	Value	Remarks
C1 to C3	0.01 μF	Necessary to all the test circuits
C4	0.1 μF	
R1	Open ^{Note}	In the case of Low-noise Amplifier
	180 Ω	In the case of Wideband Low-noise Amplifier with improved output level

Note In the case of Low-noise Amplifier, R1 is not mounted.

TYPICAL CHARACTERISTICS (T_A = +25 °C, unless otherwise specified)

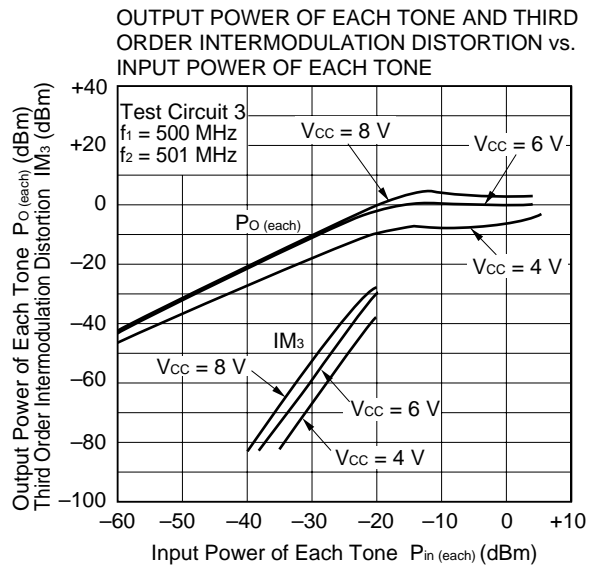
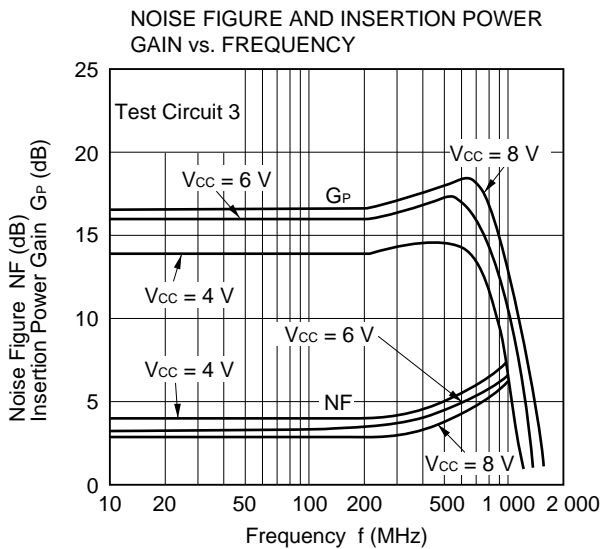
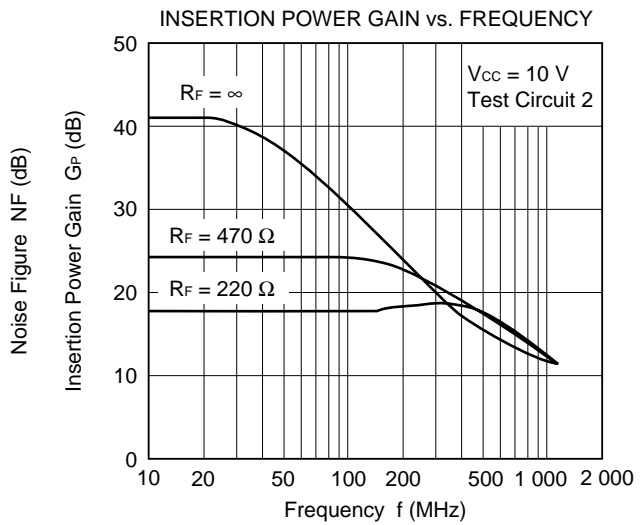
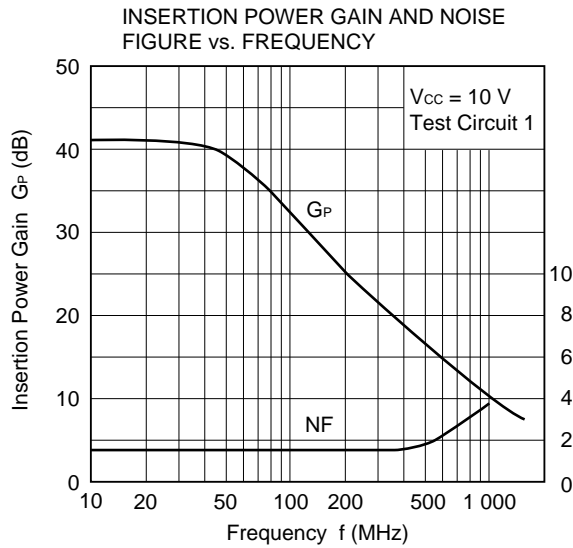
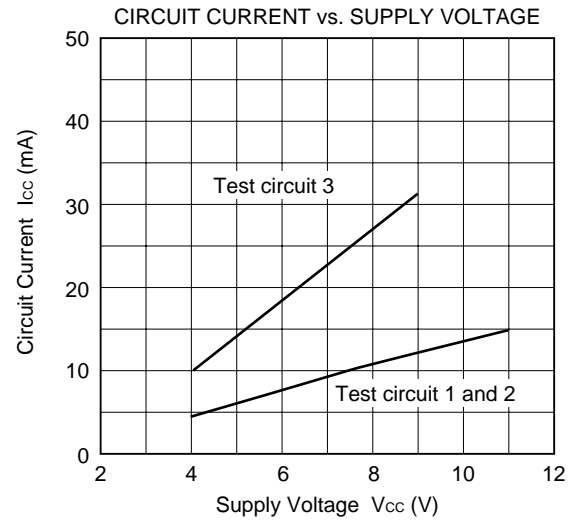
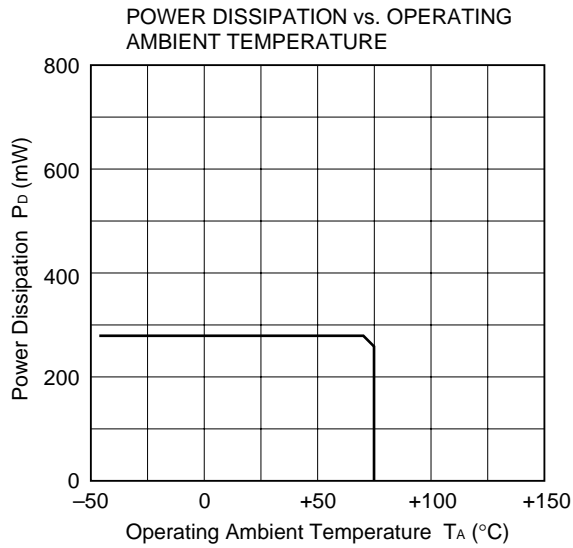

★ PACKAGE DIMENSIONS

8 PIN PLASTIC SOP (225 mil) (Unit: mm)

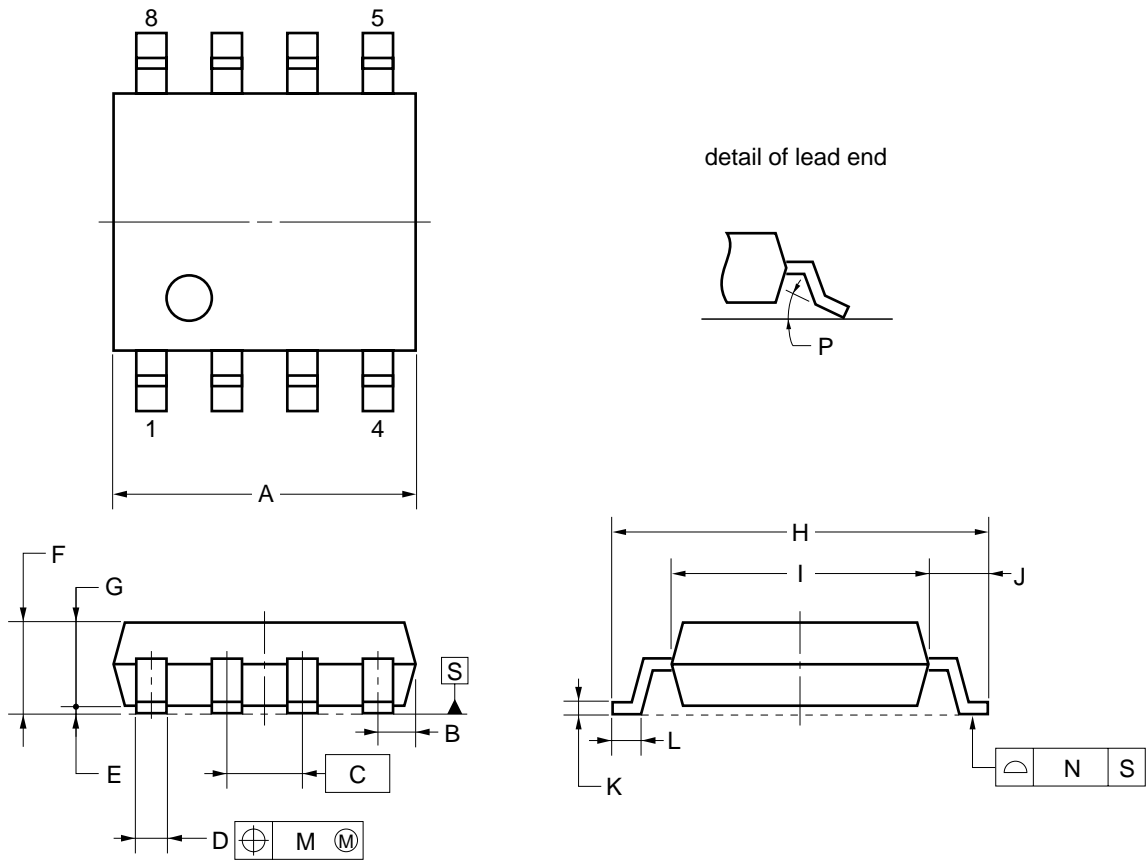

NOTE
 Each lead centerline is located within 0.12 mm of its true position (T.P.) at maximum material condition.

ITEM	MILLIMETERS
A	5.2±0.2
B	0.85 MAX.
C	1.27 (T.P.)
D	0.42 ^{+0.08} _{-0.07}
E	0.1±0.1
F	1.57±0.2
G	1.49
H	6.5±0.3
I	4.4±0.15
J	1.1±0.2
K	0.17 ^{+0.08} _{-0.07}
L	0.6±0.2
M	0.12
N	0.10
P	3° ^{+7°} _{-3°}

NOTES ON CORRECT USE

- (1) Observe precautions for handling because of electro-static sensitive devices.
- (2) Form a ground pattern as widely as possible to minimize ground impedance (to prevent undesired oscillation). All the ground pins must be connected together with wide ground pattern to decrease impedance difference.
- (3) Because the components will operate at high frequencies, apply chip capacitors and chip resistors with low parasitic inductance.
- (4) The DC capacitor must be attached to input pin and output pin.
- (5) The bypass capacitor should be attached to Vcc line.
- (6) In case of improved output level type application circuit, observe precaution not to exceed the power dissipation rating, especially in Vcc = 9 V or over.

RECOMMENDED SOLDERING CONDITIONS

This product should be soldered under the following recommended conditions. For soldering methods and conditions other than those recommended below, contact your NEC sales representative.

Soldering Method	Soldering Conditions	Recommended Condition Symbol
Infrared Reflow	Package peak temperature: 235 °C or below Time: 30 seconds or less (at 210 °C) Count: 3, Exposure limit: None ^{Note}	IR35-00-3
VPS	Package peak temperature: 215 °C or below Time: 40 seconds or less (at 200 °C) Count: 3, Exposure limit: None ^{Note}	VP15-00-3
Wave Soldering	Soldering bath temperature: 260 °C or below Time: 10 seconds or less Count: 1, Exposure limit: None ^{Note}	WS60-00-1
Partial Heating	Pin temperature: 300 °C Time: 3 seconds or less (per side of device) Exposure limit: None ^{Note}	—

Note After opening the dry pack, keep it in a place below 25 °C and 65 % RH for the allowable storage period.

Caution Do not use different soldering methods together (except for partial heating).

For details of recommended soldering conditions for surface mounting, refer to information document SEMICONDUCTOR DEVICE MOUNTING TECHNOLOGY MANUAL (C10535E).

[MEMO]

[MEMO]

[MEMO]

NESAT (NEC Silicon Advanced Technology) is a trademark of NEC Corporation.

- **The information in this document is subject to change without notice. Before using this document, please confirm that this is the latest version.**
 - No part of this document may be copied or reproduced in any form or by any means without the prior written consent of NEC Corporation. NEC Corporation assumes no responsibility for any errors which may appear in this document.
 - NEC Corporation does not assume any liability for infringement of patents, copyrights or other intellectual property rights of third parties by or arising from use of a device described herein or any other liability arising from use of such device. No license, either express, implied or otherwise, is granted under any patents, copyrights or other intellectual property rights of NEC Corporation or others.
 - Descriptions of circuits, software, and other related information in this document are provided for illustrative purposes in semiconductor product operation and application examples. The incorporation of these circuits, software, and information in the design of the customer's equipment shall be done under the full responsibility of the customer. NEC Corporation assumes no responsibility for any losses incurred by the customer or third parties arising from the use of these circuits, software, and information.
 - While NEC Corporation has been making continuous effort to enhance the reliability of its semiconductor devices, the possibility of defects cannot be eliminated entirely. To minimize risks of damage or injury to persons or property arising from a defect in an NEC semiconductor device, customers must incorporate sufficient safety measures in its design, such as redundancy, fire-containment, and anti-failure features.
 - NEC devices are classified into the following three quality grades:
"Standard", "Special", and "Specific". The Specific quality grade applies only to devices developed based on a customer designated "quality assurance program" for a specific application. The recommended applications of a device depend on its quality grade, as indicated below. Customers must check the quality grade of each device before using it in a particular application.
 - Standard: Computers, office equipment, communications equipment, test and measurement equipment, audio and visual equipment, home electronic appliances, machine tools, personal electronic equipment and industrial robots
 - Special: Transportation equipment (automobiles, trains, ships, etc.), traffic control systems, anti-disaster systems, anti-crime systems, safety equipment and medical equipment (not specifically designed for life support)
 - Specific: Aircraft, aerospace equipment, submersible repeaters, nuclear reactor control systems, life support systems or medical equipment for life support, etc.
- The quality grade of NEC devices is "Standard" unless otherwise specified in NEC's Data Sheets or Data Books. If customers intend to use NEC devices for applications other than those specified for Standard quality grade, they should contact an NEC sales representative in advance.