

PRELIMINARY
 Notice ; This is not a final specification.
 some parametric limits are subject to change.

MITSUBISHI SOUND PROCESSORS

M62430FP

DIGITAL SOUND CONTROLLER WITH **SRS**surround



DESCRIPTION

The M62430FP is dual channel sound volume/quality.
 The volume section is designed to the 2 channel either simultaneously or respectively in steps of 1dB. It incorporates the ladder resistance mechanism to reduce noise and distortion.
 The tone control section is capable of controlling the tone within ± 10 dB in steps of 2dB.
 The M62430FP is built in Sound Retrieval System.

FEATURES

- Electric volume (MAIN and REC Volume)
 - Volume level..... 0dB ~ -79dB,- dB (1dB / step)
- Tone control
 - Bass / Mid / Treble , 0dB ~ ± 10 dB(2dB / step)
 - Bass boost +10dB(ON / OFF)
- **SRS** Surround
- Space/Center volume ... 0dB ~ - dB
- 4 Output ports
- Built-in microcomputer interface circuit controlled by 16-bit serial data.

PACKAGE

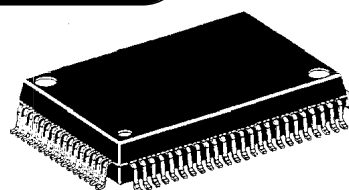

Outline 80P6N-A

0.8mm Pitch QFP
 (20.0 mmx14.0mmx2.8mm)

APPLICATION

Home Audio equipment, Radio-Cassette tape recorder, TV

RECOMMENDED OPERATING CONDITIONS

Supply voltage range.....9.0 ~ 14.6V (analog)
 4.5 ~ 5.5V (digital)
 Rated supply voltage 14.0V (analog)
 5.0V (digital)

Note !!

SRS, the SRS logo, Sound Retrieval System and "everything else is only stereo" are registered trademarks of SRS Labs, Inc.
 This device available only to licensees of SRS Lab, Inc. Licensing and application information may be obtained from SRS Lab, Inc.
 Mitsubishi Electric Corporation assumes no responsibility for any damage, or infringement of any third-party's rights, originating in the use of any product data, diagrams, charts or circuit application examples contained in these materials.

SYSTEM BLOCK DIAGRAM

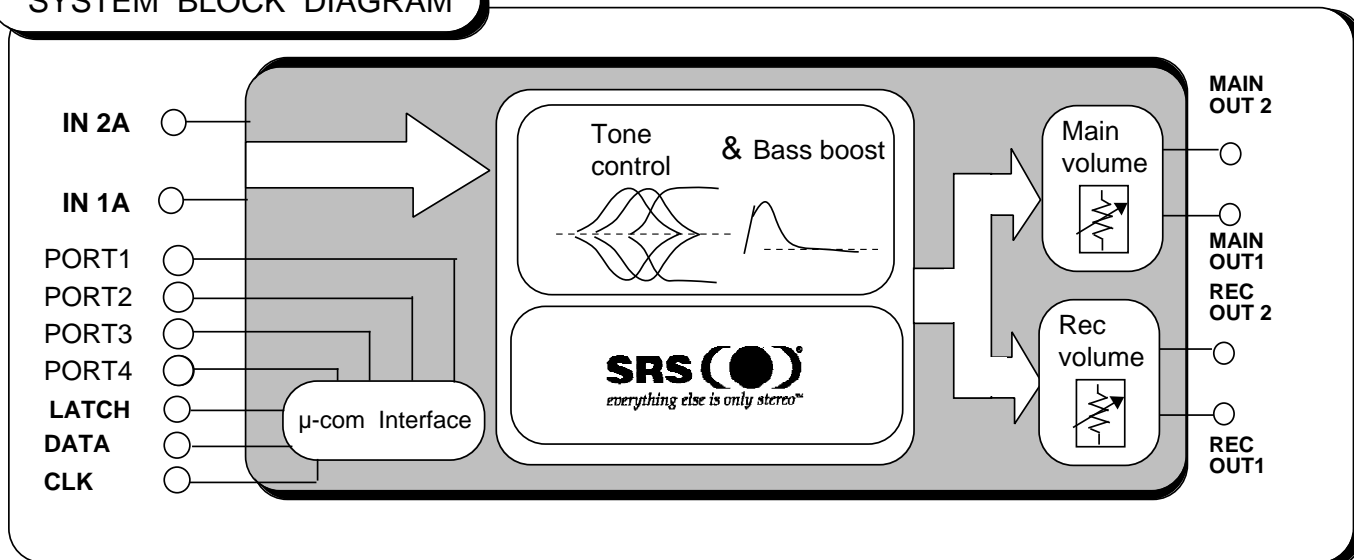

PRELIMINARY
 Notice ; This is not a final specification.
 some parametric limits are subject to change.

MITSUBISHI SOUND PROCESSORS

M62430FP

DIGITAL SOUND CONTROLLER WITH **SRS**surround

PIN CONFIGURATION AND IC INTERNAL BLOCK DIAGRAM

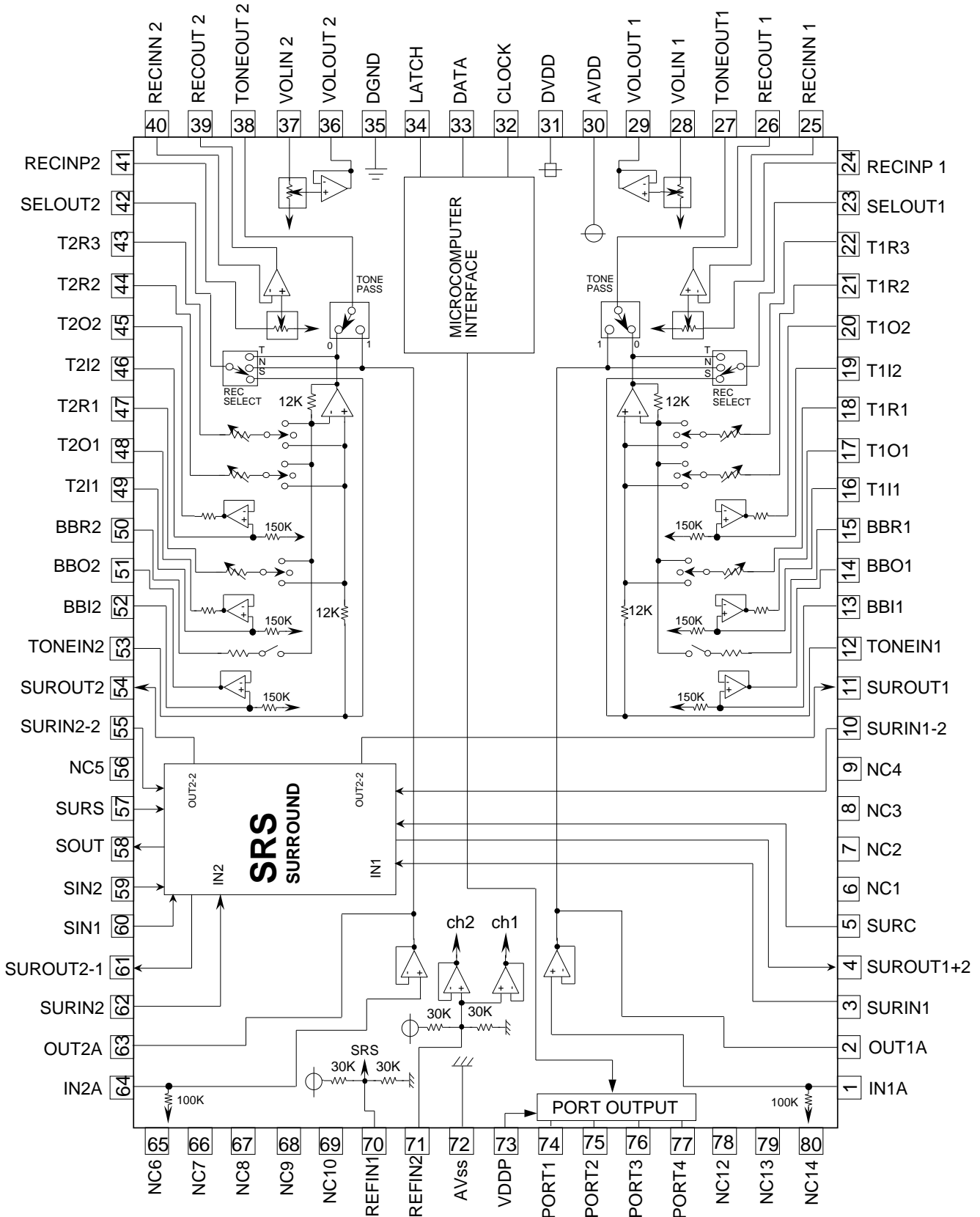

PRELIMINARY
 Notice ; This is not a final specification.
 some parametric limits are subject to change.

MITSUBISHI SOUND PROCESSORS

M62430FP

DIGITAL SOUND CONTROLLER WITH **SRS**surround

ABSOLUTE MAXIMUM RATINGS

Symbol	Parameter	Conditions	Ratings	Unit
VDD	Supply Voltage		16.0	V
Pd	Power dissipation	Ta 25°C	1.25	W
K _θ	Thermal derating	Ta>25°C *standard board	12.5	mW/°C
Topr	Operating temperature		-20 ~+55	°C
Tstg	Storage temperature		-55 ~+125	°C

THERMAL DERATING
(MAXIMUM RATING)

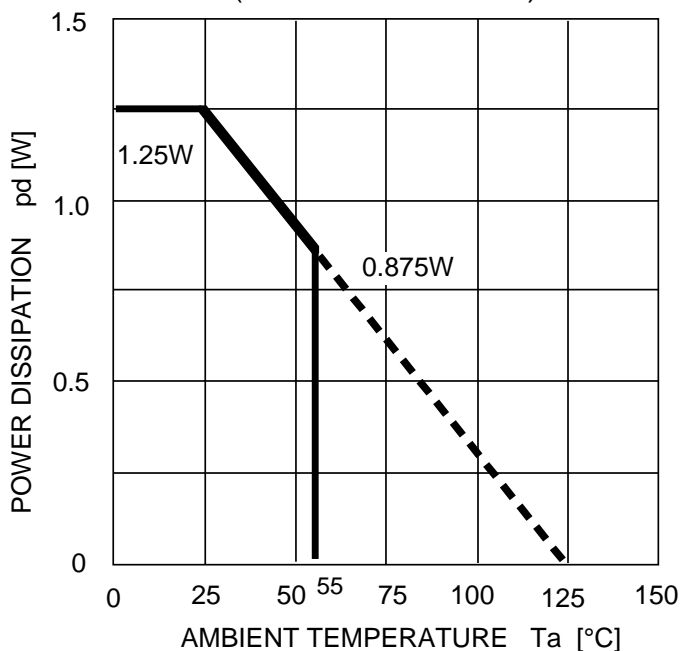

- *Standard board
- board size 140mmx140mm
 - board thickness 1.6mm
 - board material glass epoxy
 - copper pattern
 - copper thickness 18 μm
 - copper size 0.25mm(width)
50mm (length/lead)

PRELIMINARY
 Notice ; This is not a final specification.
 some parametric limits are subject to change.

MITSUBISHI SOUND PROCESSORS

M62430FP

DIGITAL SOUND CONTROLLER WITH **SRS**surround

RECOMMENDED OPERATING CONDITION

Parameter	Symbol	Condition	MIN	TYP	MAX	Unit
Analog Supply Voltage	AVDD		9.0	14.0	14.6	V
PORT Supply Voltage	VDDP	AVDD VDDP	4.5	5.0	14.6	V
Digital Supply Voltage	DVDD		4.5	5.0	5.5	V
High-level Input Voltage	VIH		DVDD-0.7	—	DVDD	V
Low-level Input Voltage	VIL		0	—	DGND+0.7	V

DATA TIMING (Recommended conditions)

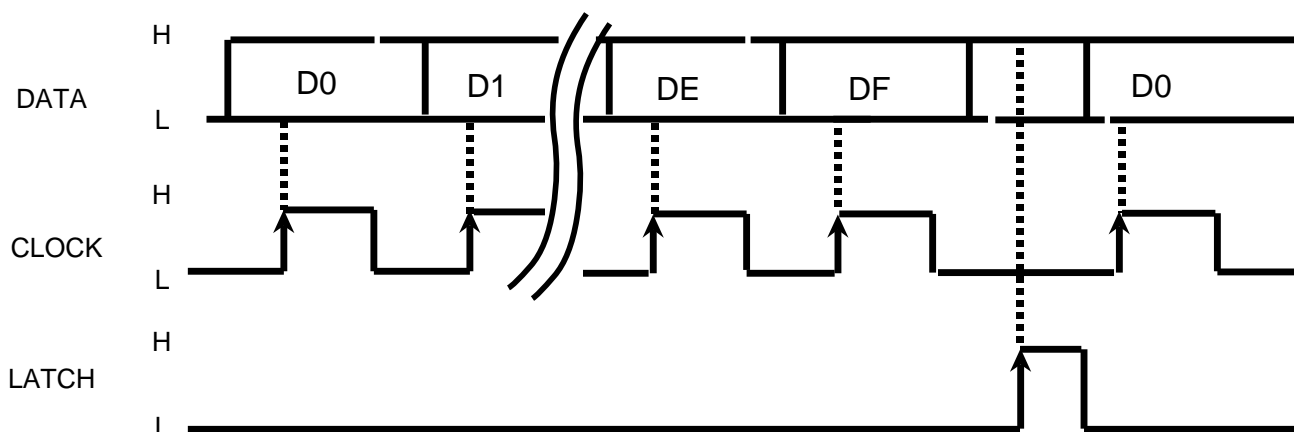

note : CLOCK and LATCH function at raising edges of pulse .

PRELIMINARY
 Notice ; This is not a final specification.
 some parametric limits are subject to change.

MITSUBISHI SOUND PROCESSORS

M62430FP

DIGITAL SOUND CONTROLLER WITH **SRS**surround

CLOCK, DATA, LATCH TIMING

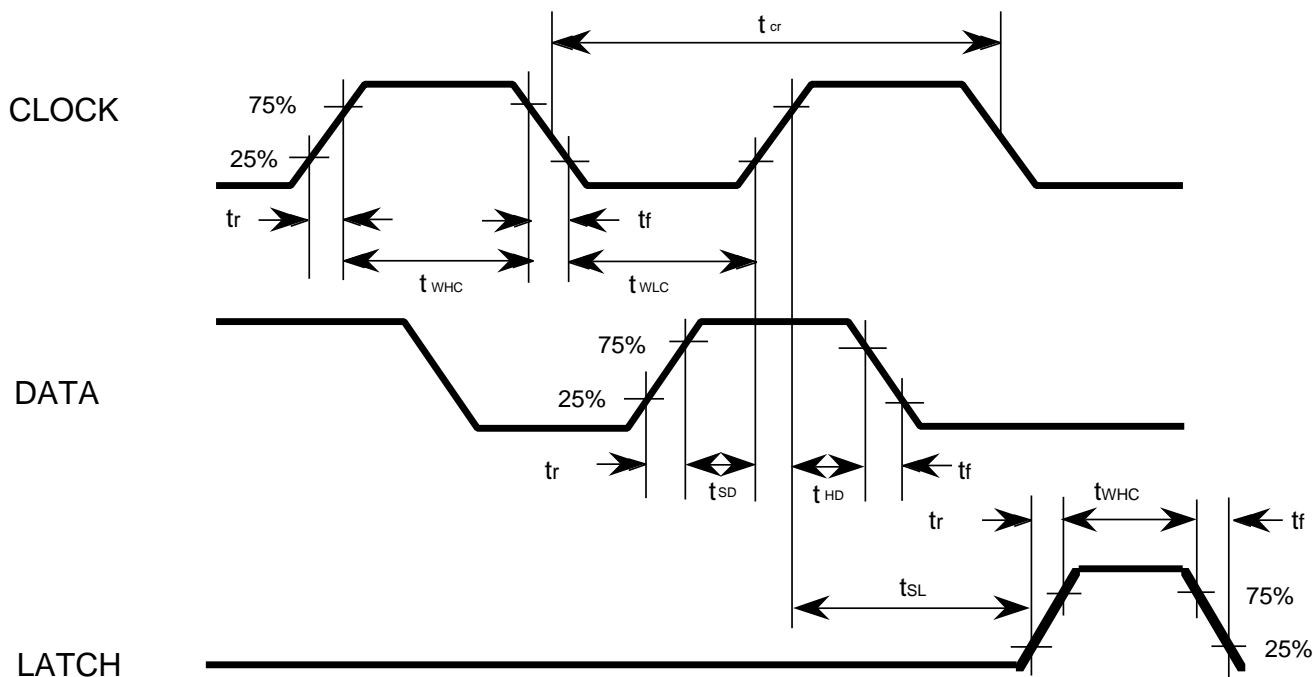

DIGITAL BLOCK TIMING REGULATION

Symbol	Parameter	Limits			Unit
		Min	typ	Max	
t_{cr}	CLOCK cycle time	8	-	-	μsec
t_{WHC}	CLOCK pulse width ("H"level)	3.2	-	-	
t_{WLC}	CLOCK pulse width ("L"level)	3.2	-	-	
t_r	CLOCK,DATA,LATCH rise time	-	-	0.8	
t_f	CLOCK,DATA,LATCH fall time	-	-	0.8	
t_{SD}	DATA setup time	1.6	-	-	
t_{HD}	DATA hold time	1.6	-	-	
t_{SL}	LATCH setup time	2	-	-	
t_{WHL}	LATCH pulse width	3.2	-	-	

PRELIMINARY
 Notice ; This is not a final specification.
 some parametric limits are subject to change.

MITSUBISHI SOUND PROCESSORS

M62430FP

DIGITAL SOUND CONTROLLER WITH **SRS**surround

DIGITAL CONTROL SPECIFICATION

Fore kinds of input format options are available by changing slot settings of DE and DF.
 (When the IC is powered up , the internal settings are not fixed.)

- (1)
- | DO1 | D11 | D21 | D31 | D41 | D51 | D61 | D71 | D81 | D91 | DA1 | DB1 | DC1 | DD1 | DE | DF |
|---------------------|-----|-----|-----|------------------|-----|-----|-----|-------------------|-----|-----|-----|-------------------------------|------------------------------|----|----|
| TONE CONTROL TREBLE | | | | TONE CONTROL MID | | | | TONE CONTROL BASS | | | | BASS BOOST
1: ON
0: OFF | TONE PASS
1: ON
0: OFF | 0 | 0 |
- (2)
- | DO2 | D12 | D22 | D32 | D42 | D52 | D62 | D72 | D82 | D92 | DA2 | DB2 | DC2 | DD2 | DE | DF |
|------------------|-----|-----|-----|-----|-----|-----|------------------|-----|-----|-----|-----|-----|-----|----|----|
| MAIN VOLUME CH 1 | | | | | | | MAIN VOLUME CH 2 | | | | | | | 0 | 1 |
- (3)
- | DO3 | D13 | D23 | D33 | D43 | D53 | D63 | D73 | D83 | D93 | DA3 | DB3 | DC3 | DD3 | DE | DF |
|-----------------|-----|-----|-----|-----|-----|-----|-----------------|-----|-----|-----|-----|-----|-----|----|----|
| REC VOLUME CH 1 | | | | | | | REC VOLUME CH 2 | | | | | | | 1 | 0 |
- (4)
- | DO4 | D14 | D24 | D34 | D44 | D54 | D64 | D74 | D84 | D94 | DA4 | DB4 | DC4 | DD4 | DE | DF |
|----------------|-----|-----|-----|-----------------|-----|-----|---------------------------------|---------------|---------------------|---------------------|---------------------|---------------------|-----|----|----|
| "Space" VOLUME | | | & | "Center" VOLUME | | | SRS SURROUND
1: ON
0: OFF | REC SELEC TOR | PORT1
1:H
0:L | PORT2
1:H
0:L | PORT3
1:H
0:L | PORT4
1:H
0:L | 1 | 1 | |

PRELIMINARY
 Notice ; This is not a final specification.
 some parametric limits are subject to change.

MITSUBISHI SOUND PROCESSORS

M62430FP

DIGITAL SOUND CONTROLLER WITH **SRS**surround

SETTING CODE

(1) Tone control (bass / mid / treble)

ATT	treble	D01	D11	D21	D31
	mid	D41	D51	D61	D71
	bass	D81	D91	DA1	DB1
- 10dB	1	1	1	0	0
- 8dB	1	1	0	0	0
- 6dB	1	0	1	1	0
- 4dB	1	0	1	0	0
- 2dB	1	0	0	1	0
+ 0dB	0	0	0	0	0
+ 2dB	0	0	0	1	0
+ 4dB	0	0	1	0	0
+ 6dB	0	0	1	1	0
+ 8dB	0	1	0	0	0
+ 10dB	0	1	1	0	0

(2) Bass boost

ATT	DC1
+ 0dB	0
+10dB	1

(3) REC selector

	D84	D94
normal	0	0
surround	0	1
tone	1	0

(4) Port output

		DA4	DB4	DC4	DD4
PORT1	0	L	-	-	-
	1	H	-	-	-
PORT2	0	-	L	-	-
	1	-	H	-	-
PORT3	0	-	-	L	-
	1	-	-	H	-
PORT4	0	-	-	-	L
	1	-	-	-	H

(5) Surround control ("Space"vol / "Center"vol)

ATT	"S"vol	D04	D14	D24	D64
	"C"vol	D34	D44	D54	
0dB	0	0	0	0	X
-3dB	0	0	1	0	X
-6dB	0	1	0	0	X
-9dB	0	1	1	0	X
-12dB	1	0	0	0	X
-15dB	1	0	1	0	X
-18dB	1	1	0	0	X
-21dB	1	1	1	0	0
- dB	1	1	1	1	1

Note : Do not input other data than the above.

PRELIMINARY
 Notice ; This is not a final specification.
 some parametric limits are subject to change.

MITSUBISHI SOUND PROCESSORS

M62430FP

DIGITAL SOUND CONTROLLER WITH **SRS**surround

(6)-1 MAIN VOLUME / REC VOLUME (0~ -39dB)

Note : Do not input other data than the above.

A T T	MAIN VOLUME CH 1	D02	D12	D22	D32	D42	D52	D62
	MAIN VOLUME CH 2	D72	D82	D92	DA2	DB2	DC2	DD2
	REC VOLUME CH 1	D03	D13	D23	D33	D43	D53	D63
	REC VOLUME CH 2	D73	D83	D93	DA3	DB3	DC3	DD3
	-0dB	0	0	0	0	0	0	0
	-1dB	0	0	0	0	0	0	1
	-2dB	0	0	0	0	0	1	0
	-3dB	0	0	0	0	0	1	1
	-4dB	0	0	0	0	1	0	0
	-5dB	0	0	0	0	1	0	1
	-6dB	0	0	0	0	1	1	0
	-7dB	0	0	0	0	1	1	1
	-8dB	0	0	0	1	0	0	0
	-9dB	0	0	0	1	0	0	1
	-10dB	0	0	0	1	0	1	0
	-11dB	0	0	0	1	0	1	1
	-12dB	0	0	0	1	1	0	0
	-13dB	0	0	0	1	1	0	1
	-14dB	0	0	0	1	1	1	0
	-15dB	0	0	0	1	1	1	1
	-16dB	0	0	1	0	0	0	0
	-17dB	0	0	1	0	0	0	1
	-18dB	0	0	1	0	0	1	0
	-19dB	0	0	1	0	0	1	1
	-20dB	0	0	1	0	1	0	0
	-21dB	0	0	1	0	1	0	1
	-22dB	0	0	1	0	1	1	0
	-23dB	0	0	1	0	1	1	1
	-24dB	0	0	1	1	0	0	0
	-25dB	0	0	1	1	0	0	1
	-26dB	0	0	1	1	0	1	0
	-27dB	0	0	1	1	0	1	1
	-28dB	0	0	1	1	1	0	0
	-29dB	0	0	1	1	1	0	1
	-30dB	0	0	1	1	1	1	0
	-31dB	0	0	1	1	1	1	1
	-32dB	0	1	0	0	0	0	0
	-33dB	0	1	0	0	0	0	1
	-34dB	0	1	0	0	0	1	0
	-35dB	0	1	0	0	0	1	1
	-36dB	0	1	0	0	1	0	0
	-37dB	0	1	0	0	1	0	1
	-38dB	0	1	0	0	1	1	0
	-39dB	0	1	0	0	1	1	1

PRELIMINARY
 Notice ; This is not a final specification.
 some parametric limits are subject to change.

MITSUBISHI SOUND PROCESSORS

M62430FP

DIGITAL SOUND CONTROLLER WITH **SRS**surround

(6)-2 MAIN VOLUME / REC VOLUME (-40~ - dB)

Note : Do not input other data than the above.

A T T	MAIN VOLUME CH 1	D02	D12	D22	D32	D42	D52	D62
	MAIN VOLUME CH 2	D72	D82	D92	DA2	DB2	DC2	DD2
	REC VOLUME CH 1	D03	D13	D23	D33	D43	D53	D63
	REC VOLUME CH 2	D73	D83	D93	DA3	DB3	DC3	DD3
-40dB	0	1	0	1	0	0	0	0
-41dB	0	1	0	1	0	0	0	1
-42dB	0	1	0	1	0	1	0	0
-43dB	0	1	0	1	0	1	1	1
-44dB	0	1	0	1	1	0	0	0
-45dB	0	1	0	1	1	0	1	1
-46dB	0	1	0	1	1	1	1	0
-47dB	0	1	0	1	1	1	1	1
-48dB	0	1	1	0	0	0	0	0
-49dB	0	1	1	0	0	0	0	1
-50dB	0	1	1	0	0	1	0	0
-51dB	0	1	1	0	0	1	1	1
-52dB	0	1	1	0	1	0	0	0
-53dB	0	1	1	0	1	0	0	1
-54dB	0	1	1	0	1	1	1	0
-55dB	0	1	1	0	1	1	1	1
-56dB	0	1	1	1	0	0	0	0
-57dB	0	1	1	1	0	0	0	1
-58dB	0	1	1	1	0	1	0	0
-59dB	0	1	1	1	0	1	1	1
-60dB	0	1	1	1	1	0	0	0
-61dB	0	1	1	1	1	0	0	1
-62dB	0	1	1	1	1	1	1	0
-63dB	0	1	1	1	1	1	1	1
-64dB	1	0	0	0	0	0	0	0
-65dB	1	0	0	0	0	0	0	1
-66dB	1	0	0	0	0	1	0	0
-67dB	1	0	0	0	0	1	1	1
-68dB	1	0	0	0	1	0	0	0
-69dB	1	0	0	0	1	0	0	1
-70dB	1	0	0	0	1	1	0	0
-71dB	1	0	0	0	1	1	1	1
-72dB	1	0	0	1	0	0	0	0
-73dB	1	0	0	1	0	0	0	1
-74dB	1	0	0	1	0	1	0	0
-75dB	1	0	0	1	0	1	1	1
-76dB	1	0	0	1	1	0	0	0
-77dB	1	0	0	1	1	0	0	1
-78dB	1	0	0	1	1	1	0	0
-79dB	1	0	0	1	1	1	1	1
- dB	1	0	1	0	0	0	0	0

PRELIMINARY
 Notice ; This is not a final specification.
 some parametric limits are subject to change.

MITSUBISHI SOUND PROCESSORS

M62430FP

DIGITAL SOUND CONTROLLER WITH **SRS**surround

ELECTRICAL CHARACTERISTICS

(Ta=25°C, AVDD=14.0V, DVDD=5.0V, f=1kHz, unless otherwise noted.)

TONE CONTROL, BASS BOOST, VOLUME are set to 0dB)

(1) Power supply characteristics

Parameter	Symbol	Test conditions	Limits			Unit
			Min	typ	Max	
Analog circuit current	A _{Idd}	Current at pin 30 No signal	—	45	60	mA
Digital circuit current	D _{Idd}	Current at pin 31 No signal	—	0.3	1.2	mA

(2) Input / Output characteristics

Parameter	Symbol	Test conditions	Limits			Unit
			Min	typ	Max	
Input resistance	R _{in}	1pin,64pin,Ta=25°C	50	100	150	K
Maximum output voltage	V _{OM}	Input to pin1,64,Output from pin29,36 RL =10K, THD=1%	3.0	4.0	—	V _{rms}
Pass gain	G _v	Vi=0.2V _{rms} , flat, pin1,64 - 29,36 gains	-2.0	0	2.0	dB
Distortion factor	THD	Pin29,36, BW=400~30kHz Vi=0.2V _{rms} , RL=10K	—	0.003	0.09	%
	THD _{recA}	Pin26,39, BW=400~30kHz Vi=0.2V _{rms} , RL=30K	—	0.003	0.07	%
	THD _{recB}	recA : SELECTOR OUT recB : SURROUND OUT	—	0.005	0.09	%
	THD _{recC}	recC : TONE OUT				
Output noise voltage	V _{ono}	Pin29,36,Rg=10K, JIS-A, VOL=0dB	—	10	24	μV _{rms}
	V _{onop}	Pin29,36,Rg=10K, JIS-A, PASS MODE,VOL=MIN	—	3	6	μV _{rms}
	V _{recnoA}	Pin26,39,Rg=10K, JIS-A, VOL=0dB	—	4	10	μV _{rms}
	V _{recnoB}	recnoA : SELECTOR OUT recnoB : SURROUND OUT	—	8	18	μV _{rms}
	V _{recnoC}	recnoC : TONE OUT	—	10	24	μV _{rms}
Crosstalk between channels	CT	Vo=0.5V _{rms} , RL=10K, JIS-A Between pin29-36 RL=10K	—	-80	-65	dB
	CT _{rec}	Vo=0.5V _{rms} , RL=30K, JIS-A Between pin26-39 RL=10K	—	-80	-65	dB

PRELIMINARY
 Notice ; This is not a final specification.
 some parametric limits are subject to change.

MITSUBISHI SOUND PROCESSORS

M62430FP

DIGITAL SOUND CONTROLLER WITH **SRS**surround

(3) Tone control characteristics

Parameter	Symbol	Test condition	Limits			Unit
			Min	typ	Max	
Tone control voltage gain	T -10dB	Vo=0.2Vrms,f=1kHz TLEBLE,MID,BASS Input pin12,53 -29,36 gains	-12	-10	-8	dB
	T - 8dB		-10	-8	-6	dB
	T - 6dB		-7.5	-6	-4.5	dB
	T - 4dB		-5.5	-4	-2.5	dB
	T - 2dB		-3	-2	-1	dB
	T+2dB		1	2	3	dB
	T+4dB		2.5	4	5.5	dB
	T+6dB		4.5	6	7.5	dB
	T+8dB		6	8	10	dB
	T+10dB		8	10	12	dB
Bass boost voltage gain	BB10dB	f=100Hz,Vo=0.2Vrms Input pin12,53 -29,36 gains	8	10	12	dB
Balance between channel	BALT	Input pin12,53 Vo=0.2Vrms Output pin23,42, boost condition +10,-10dB	-1.5	0	+1.5	dB

(4) Port

Parameter	Symbol	Test condition	Limits			Unit
			Min	typ	Max	
Port output	Vport	RL=20K VDDP2=5V	4.0	4.9	—	V

PRELIMINARY
 Notice ; This is not a final specification.
 some parametric limits are subject to change.

MITSUBISHI SOUND PROCESSORS

M62430FP

DIGITAL SOUND CONTROLLER WITH SRSsurround

(5) **SRS**Surround characteristics (Vi=500mVrms,f=1kHz, unless otherwise noted.)

Parameter	Symbol	Test condition	Limits			Unit
			Min	typ	Max	
Feed through gain	Gvsrsf	"S" VOL : MIN "C" VOL : MIN Input : pin3,62 Output : pin11,54	-12.5	-10.5	-8.5	dB
By-pass gain	Gvsrsb	SRS OFF Input : pin3,62 Output : pin11,54	-2.0	0	+2.0	dB
L (2)- R(1) gain	GvsrsL-R	"S" VOL : MAX "C" VOL : MIN Input : pin62 Output : pin54	9.6	11.6	13.6	dB
L(2) + R(1) gain	GvsrsL+R	"S" VOL : MIN "C" VOL : MAX Input : pin62 Output : pin54	-8.0	-6.0	-4.0	dB

(R:ch1 , L:ch2 , MAX:0dB , MIN:- dB)

○ SRS Block

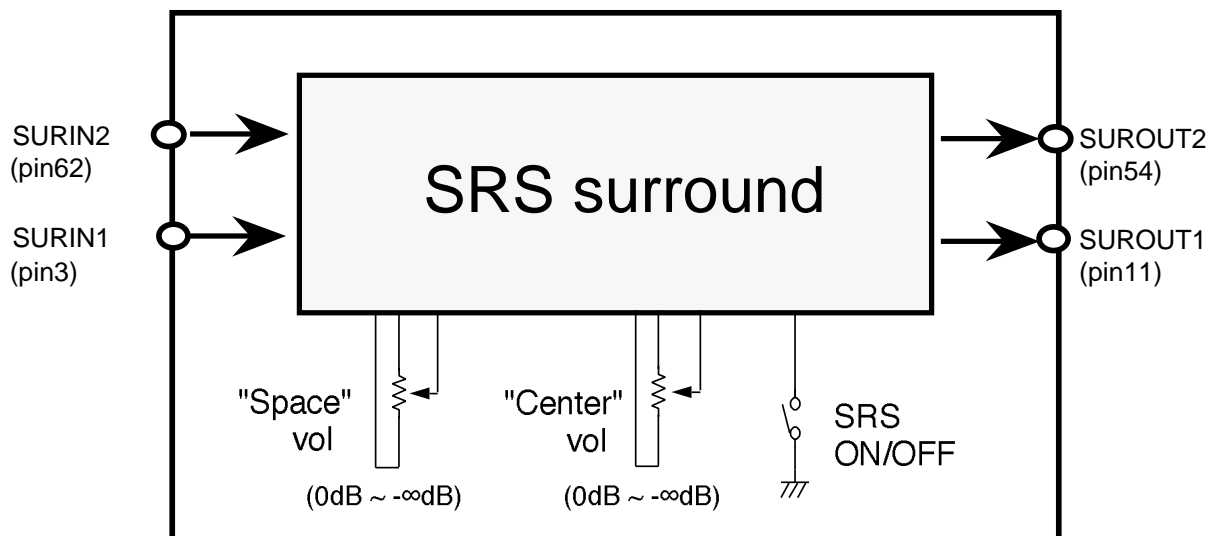

Note:

SRS, the SRS logo, Sound Retrieval System and "everything else is only stereo" are registered trademarks of SRS Labs, Inc. This device available only to licensees of SRS Lab, Inc. Licensing and application information may be obtained from SRS Lab, Inc. Please be advised that those customers intending to adopt the products described in this specification are required to obtain a license under a separate license agreement with SRS LABS, INCORPORATED ("SRS") in order to utilize the products containing SRS's intellectual property. Purchase of this product does not convey the right to sell recordings made with the Sound Retrieval System .

PRELIMINARY
 Notice ; This is not a final specification.
 some parametric limits are subject to change.

MITSUBISHI SOUND PROCESSORS

M62430FP

DIGITAL SOUND CONTROLLER WITH **SRS**surround

SYSTEM DIAGRAM 1. (1st SIDE)

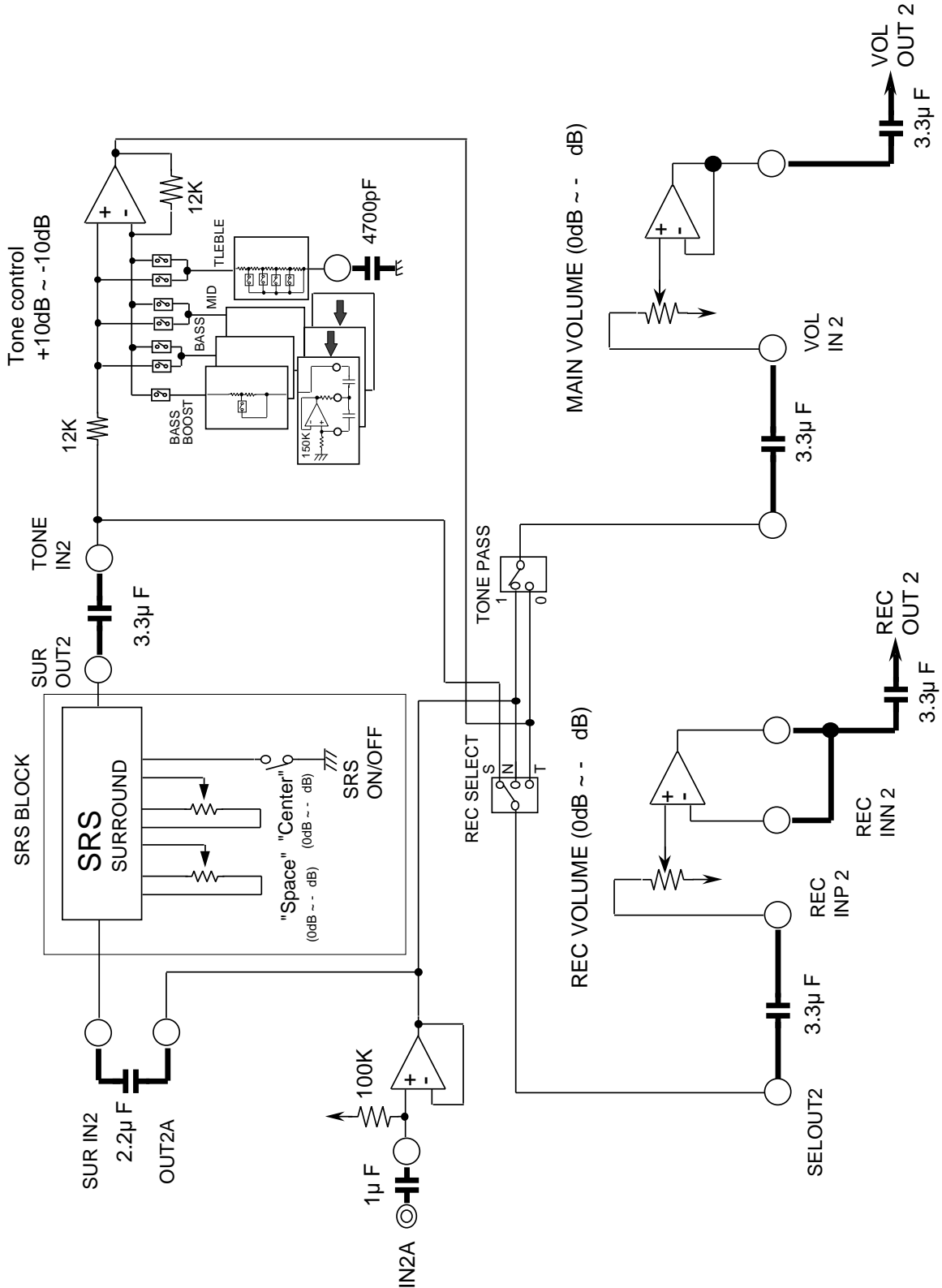

PRELIMINARY
 Notice ; This is not a final specification.
 some parametric limits are subject to change.

MITSUBISHI SOUND PROCESSORS

M62430FP

DIGITAL SOUND CONTROLLER WITH **SRS**surround

SYSTEM DIAGRAM 2.(1st SIDE)

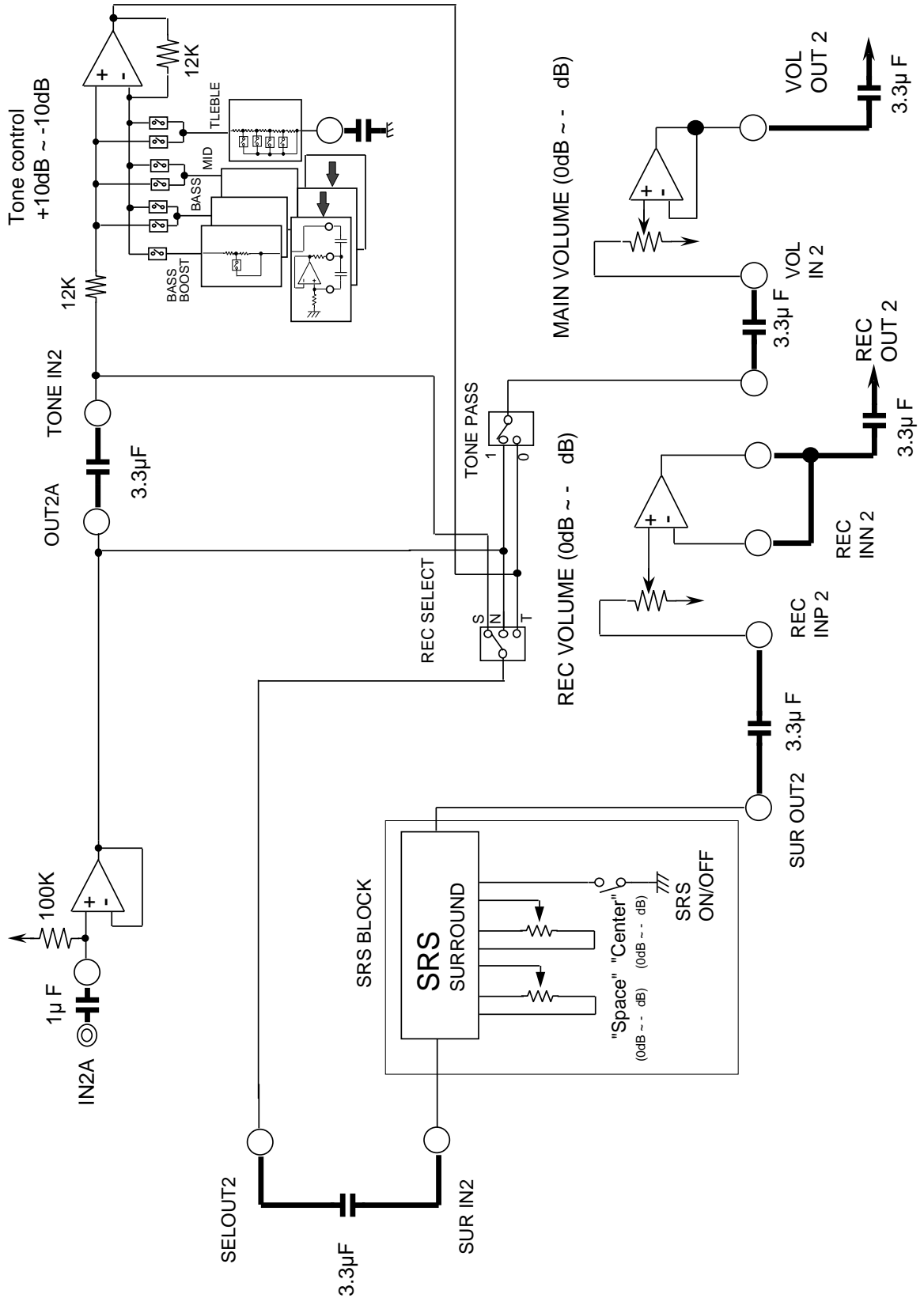

PRELIMINARY
 Notice ; This is not a final specification.
 some parametric limits are subject to change.

MITSUBISHI SOUND PROCESSORS

M62430FP

DIGITAL SOUND CONTROLLER WITH **SRS**surround

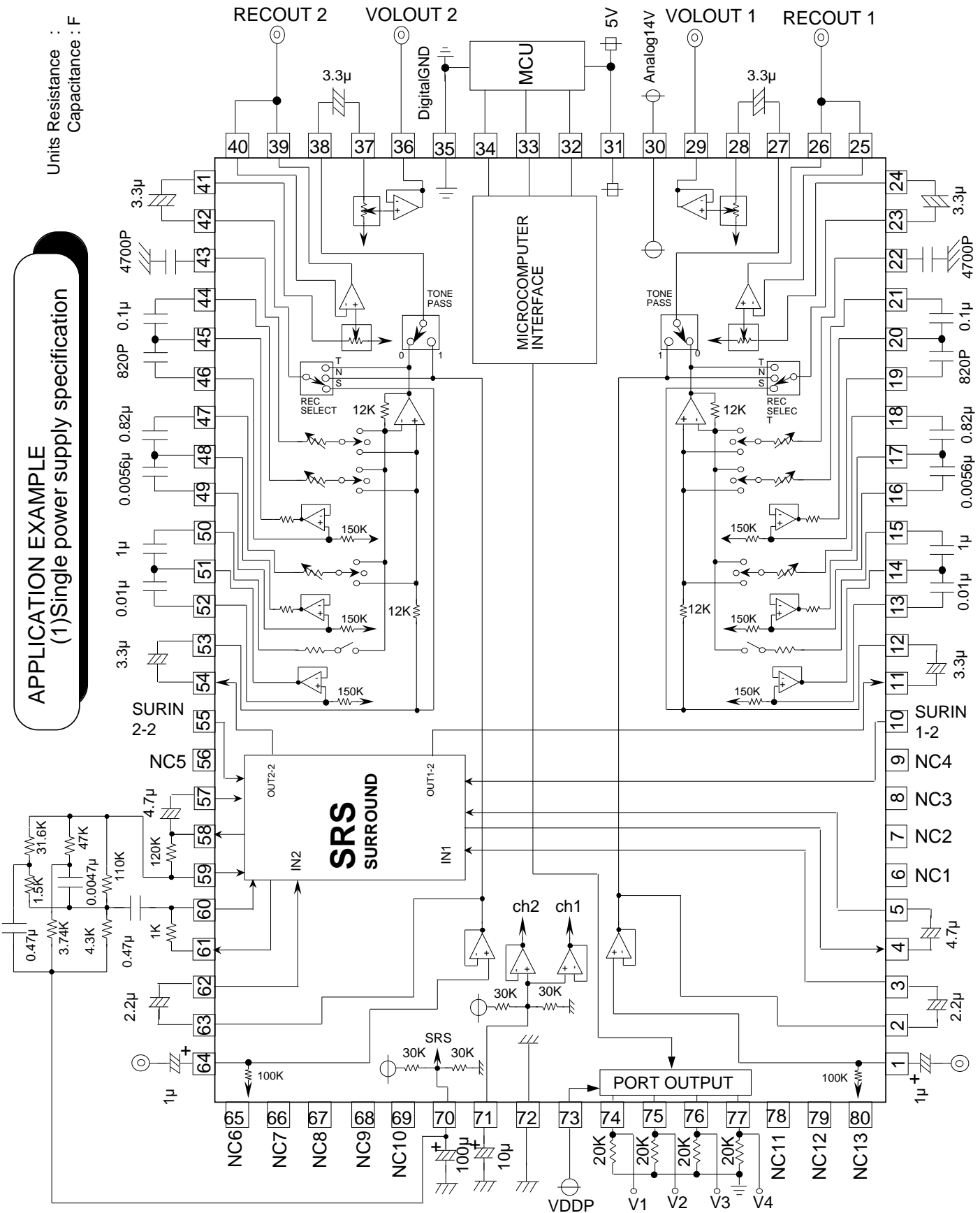

APPLICATION EXAMPLE
 (1) Single power supply specification

Units Resistance :
 Capacitance : F

PRELIMINARY
 Notice ; This is not a final specification.
 some parametric limits are subject to change.

MITSUBISHI SOUND PROCESSORS

M62430FP

DIGITAL SOUND CONTROLLER WITH **SRS**surround

Units Resistance :
 Capacitance : F

APPLICATION EXAMPLE
 (2)2 power supply specification

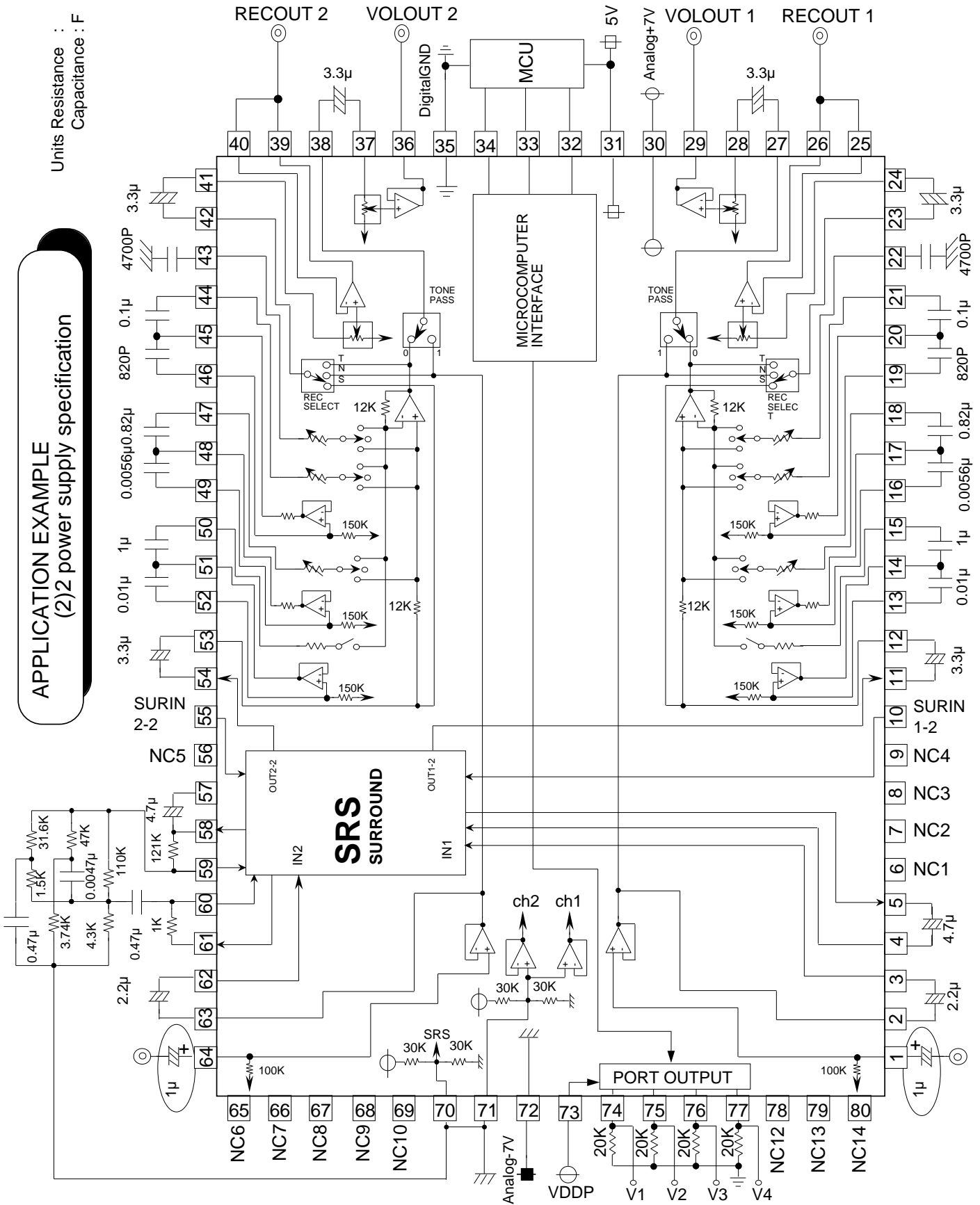

PRELIMINARY
Notice ; This is not a final specification.
some parametric limits are subject to change.

MITSUBISHI SOUND PROCESSORS

M62430FP

DIGITAL SOUND CONTROLLER WITH **SRS**surround

Keep safety first in your circuit designs !

- Mitsubishi Electric Corporation puts the maximum effort into making semiconductor products better and more reliable, but there is always the possibility that trouble may occur with them. Trouble with semiconductors may lead to personal injury, fire or property damage. Remember to give due consideration to safety when making your circuit designs, in order to prevent fires from spreading, redundancy, malfunction or other mishap.

Notes regarding these materials

- These materials are intended as a reference to assist our customers in the selection of the Mitsubishi semiconductor product best suited to the customer's application; they do not convey any license under any intellectual property rights, or any other rights, belonging to Mitsubishi Electric Corporation or a third party.
- Mitsubishi Electric Corporation assumes no responsibility for any damage, or infringement of any third-party's rights, originating in the use of any product data, diagrams, charts or circuit application examples contained in these materials.
- If these products or technologies are subject to the Japanese export control restrictions, they must be exported under a license from the Japanese government and cannot be imported into a country other than the approved destination.
Any diversion or reexport contrary to the export control laws and regulations of Japan and/or the country of destination is prohibited.