

DATA SHEET

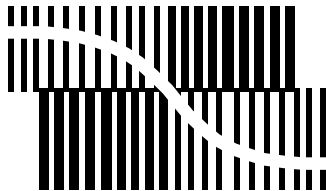

BITSTREAM CONVERSION

UDA1350AH IEC 958 audio DAC

Preliminary specification
File under Integrated Circuits, IC01

1999 Dec 16

IEC 958 audio DAC**UDA1350AH**

CONTENTS	9	LIMITING VALUES
1 FEATURES	10	THERMAL CHARACTERISTICS
1.1 General	11	CHARACTERISTICS
1.2 Control	12	TIMING CHARACTERISTICS
1.3 IEC 958 input	13	APPLICATION INFORMATION
1.4 Digital output and input interfaces	14	PACKAGE OUTLINE
1.5 Digital sound processing and DAC	15	SOLDERING
2 APPLICATIONS	15.1	Introduction to soldering surface mount packages
3 GENERAL DESCRIPTION	15.2	Reflow soldering
4 QUICK REFERENCE DATA	15.3	Wave soldering
5 ORDERING INFORMATION	15.4	Manual soldering
6 BLOCK DIAGRAM	15.5	Suitability of surface mount IC packages for wave and reflow soldering methods
7 PINNING	16	DEFINITIONS
8 FUNCTIONAL DESCRIPTION	17	LIFE SUPPORT APPLICATIONS
8.1 Operating modes		
8.2 Clock regeneration and lock detection		
8.3 Mute		
8.4 Auto mute		
8.5 Data path		
8.5.1 IEC 958 input		
8.5.2 Digital data output and input interface		
8.5.3 Audio feature processor		
8.5.4 Interpolator		
8.5.5 Noise shaper		
8.5.6 Filter stream DAC		
8.6 Control		
8.6.1 Static pin control mode		
8.6.2 L3 control mode		
8.7 L3 interface		
8.7.1 General		
8.7.2 Device addressing		
8.7.3 Register addressing		
8.7.4 Data write mode		
8.7.5 Data read mode		
8.7.6 Initialisation string		
8.7.7 Overview of L3 interface registers		
8.7.8 Writable registers		
8.7.9 Readable registers		

IEC 958 audio DAC

UDA1350AH

1 FEATURES**1.1 General**

- 2.7 to 3.6 V power supply
- Integrated digital filter and Digital-to-Analog Converter (DAC)
- Master-mode data output interface for off-chip sound processing
- $256f_s$ system clock output
- 20-bit data-path in interpolator
- High performance
- No analog post filtering required for DAC.

1.2 Control

- Controlled either by means of static pins or via the L3 microcontroller interface.

1.3 IEC 958 input

- On-chip amplifier for converting IEC 958 input to CMOS levels
- Selectable IEC 958 input channel, one out of two
- Lock indication signal available on pin LOCK
- Lock indication signal combined on-chip with the Pulse Code Modulation (PCM) status bit; in case non-PCM has been detected pin LOCK indicates out-of-lock
- Key channel-status bits available via L3 interface (lock, pre-emphasis, audio sample frequency, two channel PCM indication and clock accuracy).

1.4 Digital output and input interfaces

- When the UDA1350AH is clock master of the data output interface:
 - BCKO and WSO signals are output
 - I²S-bus or LSB-justified 16, 20 and 24 bits formats are supported.
- When the UDA1350AH is clock slave of the data input interface:
 - BCK and WS signals are input
 - I²S-bus or LSB-justified 16, 20 and 24 bits formats are supported.

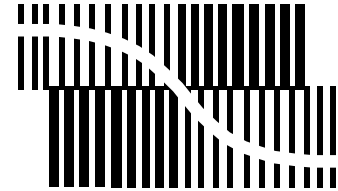

BITSTREAM CONVERSION

1.5 Digital sound processing and DAC

- Pre-emphasis information of IEC 958 input bitstream available in L3 interface register and on pins
- Automatic de-emphasis when using IEC 958 input with 32.0, 44.1 and 48.0 kHz audio sample frequencies
- Soft mute by means of a cosine roll-off circuit selectable via pin MUTE or the L3 interface
- Interpolating filter (f_s to $128f_s$) by means of a cascade of a recursive filter and a FIR filter
- Third-order noise shaper operating at $128f_s$ generates bitstream for the DAC
- Filter stream digital-to-analog converter.

2 APPLICATIONS

- Digital audio systems.

3 GENERAL DESCRIPTION

Available in two versions:

- UDA1350AH:
 - Full featured version in QFP44 package.
- UDA1350ATS:
 - Only IEC 958 input to DAC in SSOP28 package.

The UDA1350AH is a single chip IEC 958 audio decoder with an integrated stereo digital-to-analog converter employing bitstream conversion techniques.

IEC 958 audio DAC

UDA1350AH

The UDA1350AH can operate in various operating modes:

- IEC 958 input to the DAC including on-chip signal processing
- IEC 958 input via the digital data output interface to the external Digital Signal Processor (DSP)
- IEC 958 input to the DAC and a DSP
- IEC 958 input via a DSP to the DAC including on-chip signal processing
- External source data input to the DAC including on-chip signal processing.

The IEC 958 input audio data including the accompanying pre-emphasis information is available on the output data interface.

A lock indication signal is available on pin LOCK indicating that the IEC 958 decoder is locked. By default the DAC output and the data output interface are muted when the decoder is out-of-lock. However, this setting can be overruled in the L3 control mode.

4 QUICK REFERENCE DATA

SYMBOL	PARAMETER	CONDITIONS	MIN.	TYP.	MAX.	UNIT
Supplies						
V_{DDA}	analog supply voltage		2.7	3.0	3.6	V
V_{DDD}	digital supply voltage		2.7	3.0	3.6	V
$I_{DDA(DAC)}$	analog supply current of DAC	power-on	–	8.0	–	mA
		power-down	–	750	–	μ A
$I_{DDA(PLL)}$	analog supply current of PLL		–	0.7	–	mA
I_{DDD}	digital supply current		–	2.0	–	mA
$I_{DDD(C)}$	digital supply current of core		–	16.0	–	mA
P	power consumption	DAC in playback mode	–	80	–	mW
		DAC in Power-down mode	–	58	–	mW
General						
t_{rst}	reset active time		–	250	–	μ s
T_{amb}	ambient temperature		–40	–	+85	$^{\circ}$ C
Digital-to-analog converter						
$V_{o(rms)}$	output voltage (RMS value)	note 1	–	900	–	mV
(THD + N)/S	total harmonic distortion-plus-noise to signal ratio	$f_i = 1.0$ kHz tone at 0 dB	–	–90	–85	dB
		at –40 dB; A-weighted	–	–60	–55	dB
S/N	signal-to-noise ratio	$f_i = 1.0$ kHz tone; code = 0; A-weighted	95	100	–	dB
α_{cs}	channel separation	$f_i = 1.0$ kHz tone	–	96	–	dB
ΔV_o	unbalance of output voltages	$f_i = 1.0$ kHz tone	–	0.1	0.4	dB

Note

1. The DAC output voltage is proportional to the DAC power supply voltage.

IEC 958 audio DAC

UDA1350AH

5 ORDERING INFORMATION

TYPE NUMBER	PACKAGE		
	NAME	DESCRIPTION	VERSION
UDA1350AH	QFP44	plastic quad flat package; 44 leads (lead length 1.3 mm); body 10 × 10 × 1.75 mm	SOT307-2

6 BLOCK DIAGRAM

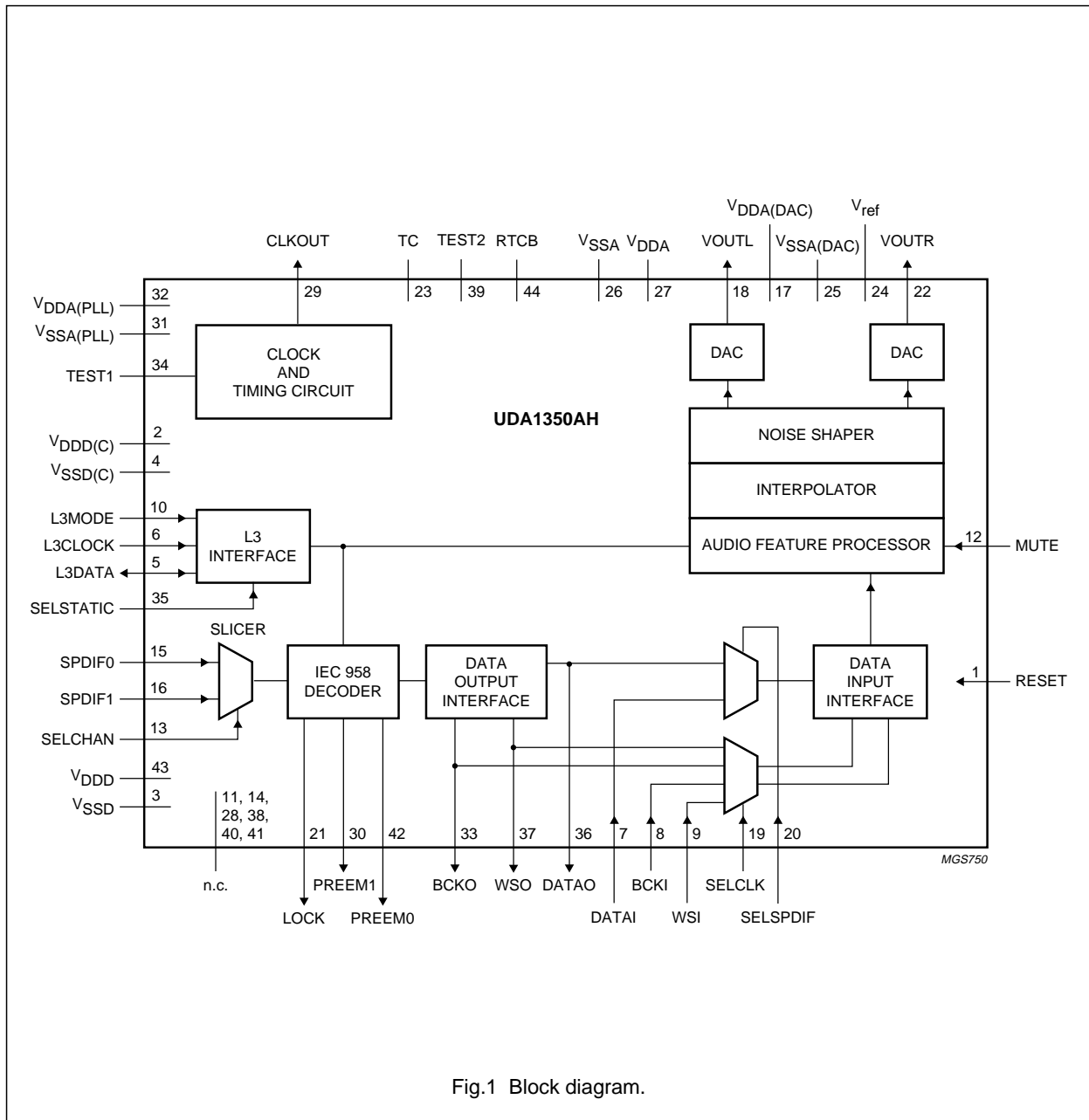

IEC 958 audio DAC

UDA1350AH

7 PINNING

SYMBOL	PIN	TYPE ⁽¹⁾	DESCRIPTION
RESET	1	DISD	reset input
V _{DD(C)}	2	DS	digital supply voltage for core
V _{SSD}	3	DGND	digital ground
V _{SSD(C)}	4	DGND	digital ground for core
L3DATA	5	DIOS	L3 interface data input and output
L3CLOCK	6	DIS	L3 interface clock input
DATAI	7	DISD	I ² S-bus data input
BCKI	8	DISD	I ² S-bus bit clock input
WSI	9	DISD	I ² S-bus word select input
L3MODE	10	DIS	L3 interface mode input
n.c.	11	–	not connected
MUTE	12	DID	mute control input
SELCHAN	13	DID	IEC 958 channel selection input
n.c.	14	–	not connected
SPDIF0	15	AI	IEC 958 channel 0 input
SPDIF1	16	AI	IEC 958 channel 1 input
V _{DDA(DAC)}	17	AS	analog supply voltage for DAC
VOU _{TL}	18	AO	DAC left channel analog output
SELCLK	19	DID	clock source for PLL selection input
SELSPDIF	20	DIU	IEC 958 data selection input
LOCK	21	DO	SPDIF and PLL lock indicator output
VOU _{TR}	22	AO	DAC right channel analog output
TC	23	DID	test pin; must be connected to digital ground (V _{SSD})
V _{ref}	24	A	DAC reference voltage
V _{SSA(DAC)}	25	AGND	analog ground for DAC
V _{SSA}	26	AGND	analog ground
V _{DDA}	27	AS	analog supply voltage
n.c.	28	–	not connected
CLKOUT	29	DO	clock output (256f _s)
PREEM1	30	DO	IEC 958 input pre-emphasis output 1
V _{SSA(PLL)}	31	AGND	analog ground for PLL
V _{DDA(PLL)}	32	AS	analog supply voltage for PLL
BCKO	33	DO	I ² S-bus bit clock output
TEST1	34	DIU	test pin 1: must be connected to digital supply voltage (V _{DD})
SELSTATIC	35	DIU	static pin control selection input
DATAO	36	DO	I ² S-bus data output
WSO	37	DO	I ² S-bus word select output
n.c.	38	–	not connected
TEST2	39	DISD	test pin 2; must be connected to digital ground (V _{SSD})
n.c.	40	–	not connected

IEC 958 audio DAC

UDA1350AH

SYMBOL	PIN	TYPE ⁽¹⁾	DESCRIPTION
n.c.	41	–	not connected
PREEM0	42	DO	IEC 958 input pre-emphasis output 0
V _{DDD}	43	DS	digital supply voltage
RTCB	44	DID	test pin; must be connected to digital ground (V _{SSD})

Note

1. See Table 1.

Table 1 Pin type references

PIN TYPE	DESCRIPTION
DS	digital supply
DGND	digital ground
AS	analog supply
AGND	analog ground
DI	digital input
DIS	digital Schmitt-triggered input
DID	digital input with internal pull-down resistor
DISD	digital Schmitt-triggered input with internal pull-down resistor
DIU	digital input with internal pull-up resistor
DO	digital output
DIO	digital input and output
DIOS	digital Schmitt-triggered input and output
A	analog reference voltage
AI	analog input
AO	analog output

IEC 958 audio DAC

UDA1350AH

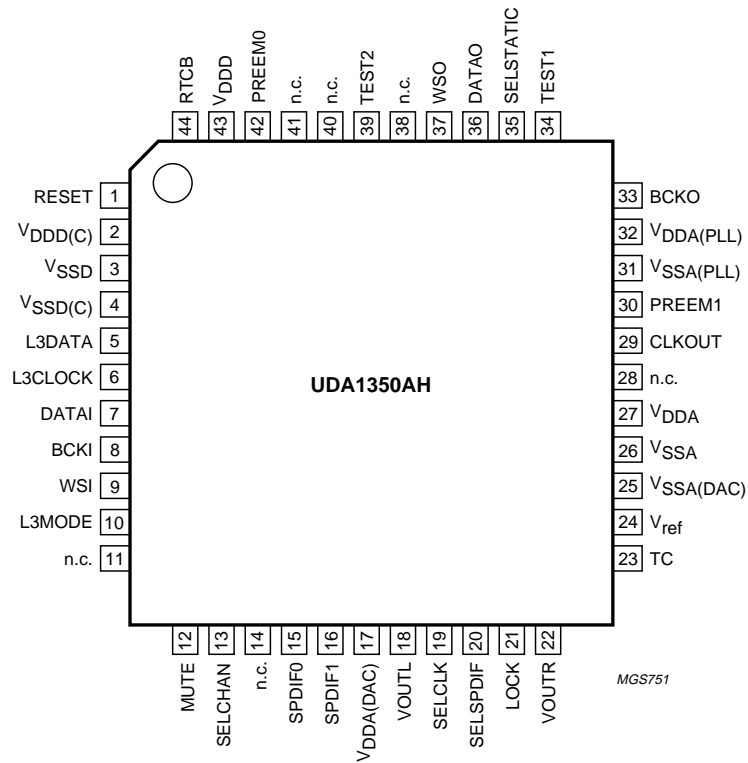

Fig.2 Pin configuration.

IEC 958 audio DAC

UDA1350AH

8 FUNCTIONAL DESCRIPTION

8.1 Operating modes

MODE	DESCRIPTION	SCHEMATIC
1	IEC 958 input to the DAC	
2	IEC 958 input via the data output interface to the DSP	
3	IEC 958 input to the DAC and via the data output interface to the DSP	
4	IEC 958 input via the data output interface to the external DSP and via the data input interface to the DAC	
5	Data input interface signal to the DAC	

The UDA1350AH is a low cost multi-purpose IEC 958 decoder DAC with a variety of operating modes.

In modes 1, 2, 3 and 4 the UDA1350AH is clock master; it generates the clock for both the outgoing and incoming digital data streams. Consequently, any device providing data for the UDA1350AH via the data input interface in mode 4 will be slave to the clock generated by the UDA1350AH.

In mode 5 the UDA1350AH locks to signal WSI from the digital data input interface. Conforming to IEC 958, the audio sample frequency of the data input interface must be between 28.0 and 54.0 kHz.

IEC 958 audio DAC

UDA1350AH

8.2 Clock regeneration and lock detection

The UDA1350AH contains an on-board PLL for regenerating a system clock from the IEC 958 input bitstream or the incoming digital data stream via the data input interface. In addition to the system clock for the on-board digital sound processing the PLL also generates a $256f_s$ clock output for use in the application. In the absence of an input signal the clock will generate a minimum frequency to warrant system functionality.

When the on-board clock has locked to the incoming frequency the lock indicator bit will be set and can be read via the L3 interface. Internally the PLL lock indication is combined with the PCM status bit of the input data stream. When both the IEC 958 decoder and the on-board clock have locked to the incoming signal and the input data stream is PCM data, then pin LOCK will be asserted. However, when the IC is locked but the PCM status bit reports non-PCM data then pin LOCK is returned to LOW level.

The lock indication output can be used, for example, for muting purposes.

8.3 Mute

The UDA1350AH is equipped with a cosine roll-off mute in the DSP data path of the DAC part. Muting the DAC, by pin MUTE (in static mode) or via bit MT (in L3 mode) will result in a soft mute as presented in Fig.3. The cosine roll-off soft mute takes 32×32 samples = 24 ms at a sampling frequency of 44.1 kHz.

When operating in the L3 control mode the device will mute on start-up. In L3 mode it is necessary to explicitly switch off the mute for audio output by means of the MT bit in the L3 register.

In the L3 mode pin MUTE does not have any function (the same holds for several other pins) and can either be left open-circuit (since it has an internal pull-down resistor) or be connected to ground.

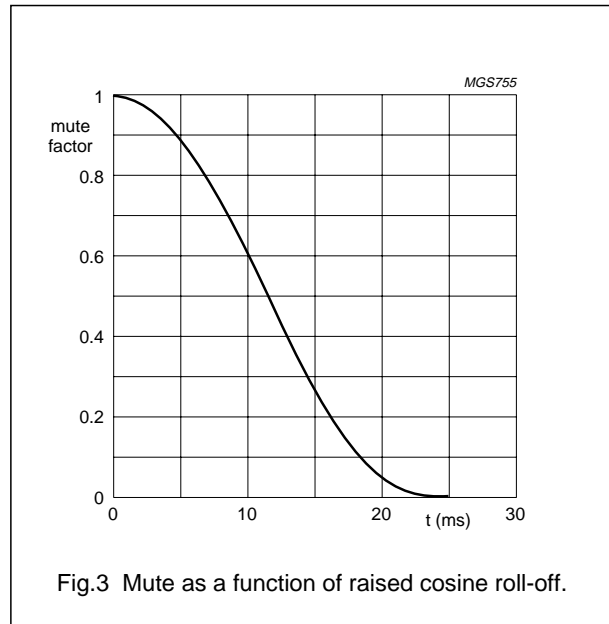

Fig.3 Mute as a function of raised cosine roll-off.

8.4 Auto mute

By default the outputs of the digital data output interface and the DAC will be muted until the IC is locked, regardless the level on pin MUTE (in static mode) or the state of bit MT of the sound feature register (in L3 mode). In this way only valid data will be passed to the outputs. This mute is done in the SPDIF interface and is a hard mute, not a cosine roll-off mute.

If needed this muting can be bypassed by setting bit AutoMT to logic 0 via the L3 interface. As a result the IC will no longer mute during out-of-lock situations.

IEC 958 audio DAC

UDA1350AH

8.5 Data path

The UDA1350AH data path consists of the slicer and the IEC 958 decoder, the digital data output and input interfaces, the audio feature processor, digital interpolator and noise shaper and the digital-to-analog converters.

8.5.1 IEC 958 INPUT

The UDA1350AH IEC 958 decoder can select one out of two IEC 958 input channels. An on-chip amplifier with hysteresis amplifies the IEC 958 input signal to CMOS level (see Fig.4).

All 24 bits of data for left and right are extracted from the input bitstream as well as several of the IEC 958 key channel-status bits.

The extracted key parameters are:

- Pre-emphasis
- Audio sample frequency
- Two-channel PCM indicator
- Clock accuracy.

Both the lock indicator and the key channel status bits are accessible via the L3 interface.

The UDA1350AH supports the following sample frequencies and data bit rates:

- $f_s = 32.0$ kHz, resulting in a data rate of 2.048 Mbits/s
- $f_s = 44.1$ kHz, resulting in a data rate of 2.8224 Mbits/s
- $f_s = 48.0$ kHz, resulting in a data rate of 3.072 Mbits/s.

The UDA1350AH supports timing level I, II and III as specified by the IEC 958 standard.

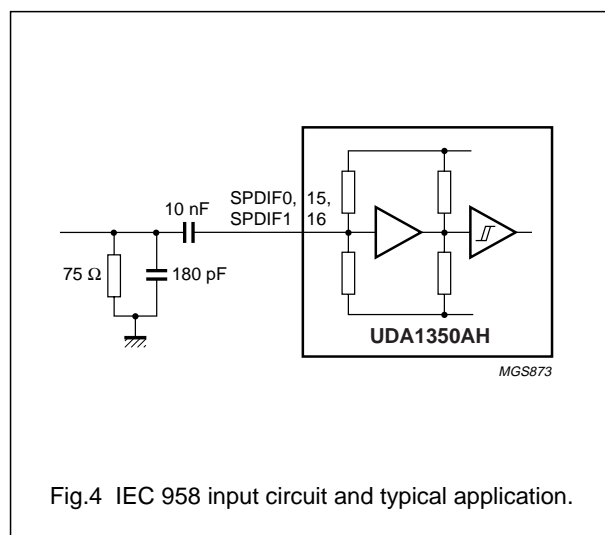

8.5.2 DIGITAL DATA OUTPUT AND INPUT INTERFACE

The digital data interface enables the exchange of digital data to and from an external signal processing device.

The digital output and input formats are identical by design. The possible formats are (see Fig.5):

- I²S-bus with a word length of up to 24 bits
- LSB-justified with a word length of 16 bits
- LSB-justified with a word length of 20 bits
- LSB-justified with a word length of 24 bits.

Important: the edge of the WS signal **must** fall on the negative edge of the BCK signal at all times for proper operation of the input and output interface (see Fig.8).

In the static pin control mode the format is selected by means of pins L3MODE and L3DATA. In the L3 control mode the format defaults to the I²S-bus settings and is programmable via the L3 interface.

The IEC 958 decoder provides the pre-emphasis information from the IEC 958 input bitstream to pins PREEM0 and PREEM1 and to the L3 interface register.

Controlling the de-emphasis is different for the two modes:

- Static pin control mode:
 - For IEC 958 input de-emphasis is automatically done, but for I²S-bus input de-emphasis is not possible.
- L3 control mode:
 - IEC 958 input: bit SPDSEL must be set to logic 1 and de-emphasis is done automatically.
 - I²S-bus input: bit SPDSEL must be set to logic 0 and de-emphasis can be controlled via bits DE0 and DE1.

IEC 958 audio DAC

UDA1350AH

8.5.3 AUDIO FEATURE PROCESSOR

The audio feature processor automatically provides de-emphasis for the IEC 958 data stream in the static pin control mode and default mute at start-up in the L3 control mode.

When used in the L3 control mode it provides the following additional features:

- Volume control using 6 bits
- Bass boost control using 4 bits
- Treble control using 2 bits
- Mode selection of the sound processing bass boost and treble filters: flat, minimum and maximum
- Soft mute control with raised cosine roll-off
- De-emphasis selection of the incoming data stream for $f_s = 32.0, 44.1$ and 48.0 kHz.

8.5.4 INTERPOLATOR

The UDA1350AH includes an on-board interpolating filter which converts the incoming data stream from $1f_s$ to $128f_s$ by cascading a recursive filter and a FIR filter.

Table 2 Interpolator characteristics

PARAMETER	CONDITIONS	VALUE (dB)
Pass-band ripple	0 to $0.45f_s$	± 0.03
Stop band	$>0.65f_s$	-50
Dynamic range	0 to $0.45f_s$	115
DC gain	-	-3.5

8.5.5 NOISE SHAPER

The third-order noise shaper operates at $128f_s$. It shifts in-band quantization noise to frequencies well above the audio band. This noise shaping technique enables high signal-to-noise ratios to be achieved. The noise shaper output is converted into an analog signal using a filter stream digital-to-analog converter.

8.5.6 FILTER STREAM DAC

The Filter Stream DAC (FSDAC) is a semi-digital reconstruction filter that converts the 1-bit data stream of the noise shaper to an analog output voltage. The filter coefficients are implemented as current sources and are summed at virtual ground of the output operational amplifier. In this way very high signal-to-noise performance and low clock jitter sensitivity is achieved. A post filter is not needed due to the inherent filter function of the DAC. On-board amplifiers convert the FSDAC output current to an output voltage signal capable of driving a line output.

The output voltage of the FSDAC is scaled proportionally with the power supply voltage.

IEC 958 audio DAC

UDA1350AH

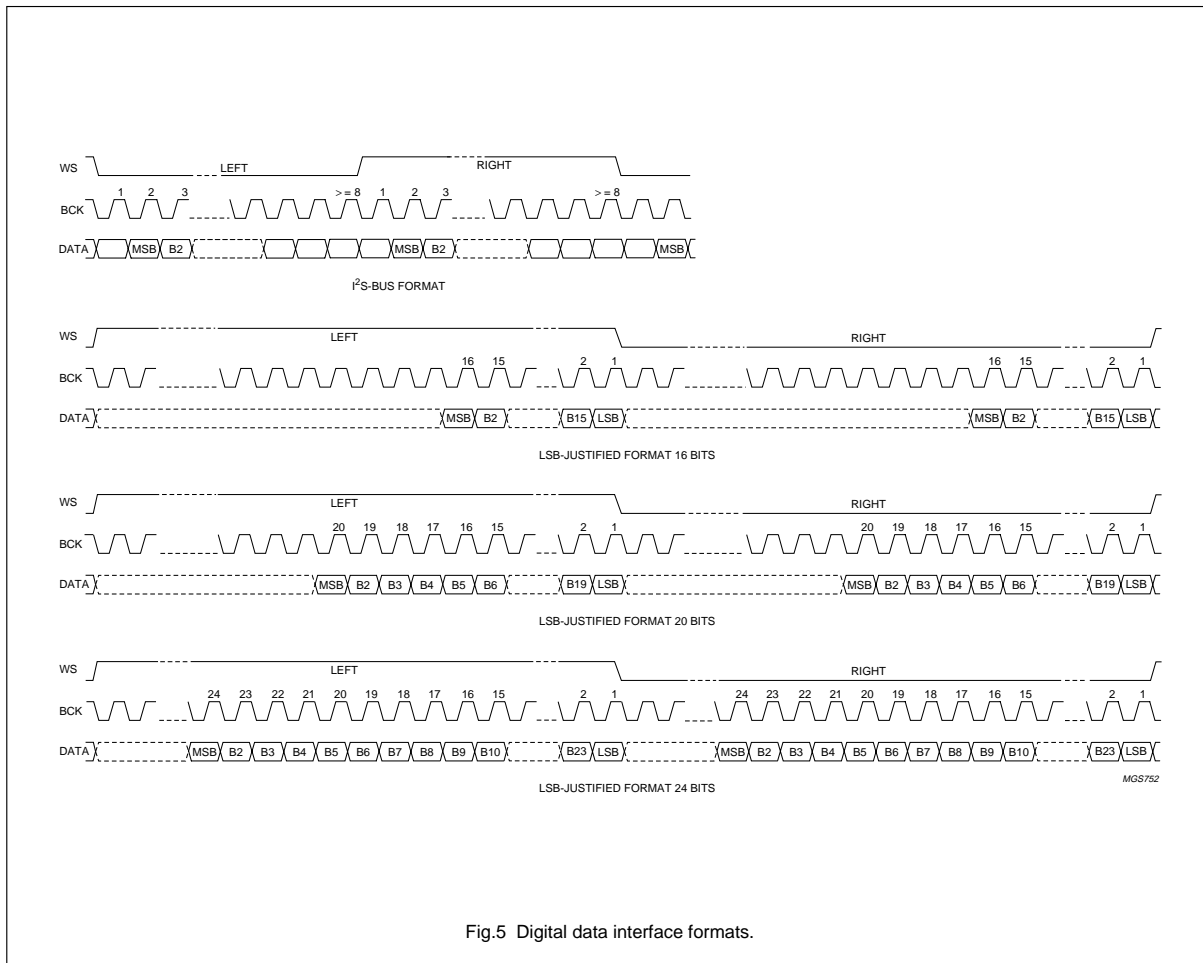

Fig.5 Digital data interface formats.

IEC 958 audio DAC

UDA1350AH

8.6 Control

The UDA1350AH can be controlled by means of static pins or via the L3 interface. For optimum use of the features of the UDA1350AH the L3 control mode is recommended since only basic functions are available in the static pin control mode.

It should be noted that the static pin control mode and L3 control mode are mutual exclusive. In the static pin control mode pins L3MODE and L3DATA are used to select the format for the data output and input interface.

8.6.1 STATIC PIN CONTROL MODE

The default values for all non-pin controlled settings are identical to the default values at start-up in the L3 control mode.

Table 3 Pin description of static pin control mode

PIN	NAME	VALUE	FUNCTION
Mode selection pin			
35	SELSTATIC	1	select static pin control mode; must be connected to V_{DD}
Input pins			
1	RESET	0	normal operation
		1	reset
6	L3CLOCK	0	must be connected to V_{SSD}
10 and 5	L3MODE and L3DATA	00	select I ² S-bus format for digital data interface
		01	select LSB-justified format 16 bits for digital data interface
		10	select LSB-justified format 20 bits for digital data interface
		11	select LSB-justified format 24 bits for digital data interface
12	MUTE	0	normal operation
		1	mute active
13	SELCHAN	0	select input SPDIF0 (channel 0)
		1	select input SPDIF1 (channel 1)
19	SELCLK	0	slave to f_s from IEC 958; master on data output and input interfaces
		1	slave to f_s from digital data input interface
20	SELSPDIF	0	select data from digital data interface to DAC output
		1	select data from IEC 958 decoder to DAC output
Status pins			
21	LOCK	0	clock regeneration or IEC 958 decoder out-of-lock or non-PCM data detected
		1	clock regeneration and IEC 958 decoder locked plus PCM data detected
30 and 42	PREEM1 and PREEM0	00	IEC 958 input: no pre-emphasis
		01	IEC 958 input: $f_s = 32.0$ kHz with pre-emphasis
		10	IEC 958 input: $f_s = 44.1$ kHz with pre-emphasis
		11	IEC 958 input: $f_s = 48.0$ kHz with pre-emphasis
Test pins			
23	TC	0	must be connected to digital ground (V_{SSD})
34	TEST1	1	must be connected to digital supply voltage (V_{DD})
39	TEST2	0	must be connected to digital ground (V_{SSD})
44	RTCB	0	must be connected to digital ground (V_{SSD})

IEC 958 audio DAC

UDA1350AH

8.6.2 L3 CONTROL MODE

The L3 control mode allows maximum flexibility in controlling the UDA1350AH.

It should be noted that in the L3 control mode several base-line functions are still controlled by pins on the device and that on start-up in the L3 control mode the output is explicitly muted by bit MT via the L3 interface.

Also it should be noted that in using the L3 control mode, an initialisation string is needed after power-up of the device for reliable operation.

Table 4 Pin description in the L3 control mode

PIN	NAME	VALUE	FUNCTION
Mode selection pin			
35	SELSTATIC	0	select L3 control mode; must be connected to V_{SSD}
Input pins			
1	RESET	0	normal operation
		1	reset
5	L3DATA	–	must be connected to the L3-bus
6	L3CLOCK	–	must be connected to the L3-bus
10	L3MODE	–	must be connected to the L3-bus
Status pins			
21	LOCK	0	clock regeneration or IEC 958 decoder out-of-lock
		1	clock regeneration and IEC 958 decoder locked
30 and 42	PREEM1 and PREEM0	00	IEC 958 input: no-pre-emphasis
		01	IEC 958 input: $f_s = 32.0$ kHz with pre-emphasis
		10	IEC 958 input: $f_s = 44.1$ kHz with pre-emphasis
		11	IEC 958 input: $f_s = 48.0$ kHz with pre-emphasis
Test pins			
23	TC	0	must be connected to ground (V_{SSD})
34	TEST1	1	must be connected to supply voltage (V_{DDD})
39	TEST2	0	must be connected to ground (V_{SSD})
44	RTCB	0	must be connected to ground (V_{SSD})

IEC 958 audio DAC

UDA1350AH

8.7 L3 interface**8.7.1 GENERAL**

The UDA1350AH has an L3 microcontroller interface and all the digital sound processing features and various system settings can be controlled by a microcontroller.

The controllable settings are:

- Restoring L3 defaults
- Power-on
- Selection of input channel, clock source, DAC input and external input format
- Selection of filter mode and settings of treble and bass boost
- Volume settings
- Selection of soft mute via cosine roll-off (only effective in L3 control mode) and bypass of auto mute
- Selection of de-emphasis.

The readable settings are:

- Mute status of interpolator
- PLL locked
- SPDIF input signal locked
- Audio Sample Frequency (ASF)
- Valid PCM data detected
- Pre-emphasis of the IEC 958 input signal
- Accuracy of the Clock (ACC).

The exchange of data and control information between the microcontroller and the UDA1350AH is accomplished through a serial hardware L3 interface comprising the following pins:

- L3DATA: data line
- L3MODE: mode line
- L3CLK: clock line.

The exchange of bytes via the L3 interface is LSB first.

The L3 format has two modes of operation:

- Address mode
- Data transfer mode.

The address mode is used to select a device for a subsequent data transfer. The address mode is characterized by L3MODE being LOW and a burst of 8 pulses on L3CLOCK, accompanied by 8 bits (see Fig.6).

The data transfer mode is characterized by L3MODE being HIGH and is used to transfer one or more bytes representing a register address, instruction or data.

Basically two types of data transfers can be defined:

- Write action: data transfer **to** the device
- Read action: data transfer **from** the device.

Remark: when the device is powered up, at least one L3CLOCK pulse must be given to the L3 interface to wake-up the interface before starting sending to the device (see Fig.6). This is only needed once after the device is powered up.

8.7.2 DEVICE ADDRESSING

The device address consists of one byte with:

- Bits 0 and 1 (called DOM bits) representing the type of data transfer (see Table 5)
- Bits 2 to 7 (address bits) representing a 6-bit device address.

Table 5 Selection of data transfer

DOM		TRANSFER
BIT 0	BIT 1	
0	0	not used
1	0	not used
0	1	write data or prepare read
1	1	read data

8.7.3 REGISTER ADDRESSING

After sending the device address, including Data Operating Mode (DOM) bits indicating whether the information is to be read or written, one data byte is sent using bit 0 to indicate whether the information will be read or written and bits 1 to 7 for the destination register address.

Basically there are three methods for register addressing:

1. Addressing for write data: bit 0 is logic 0 indicating a write action to the destination register, followed by bits 1 to 7 indicating the register address (see Fig.6).
2. Addressing for prepare read: bit 0 is logic 1 indicating that data will be read from the register (see Fig.7).
3. Addressing for data read action: in this case the device returns a register address prior to sending data from that register. When bit 0 is logic 0, the register address is valid; in case bit 0 is logic 1 the register address is invalid.

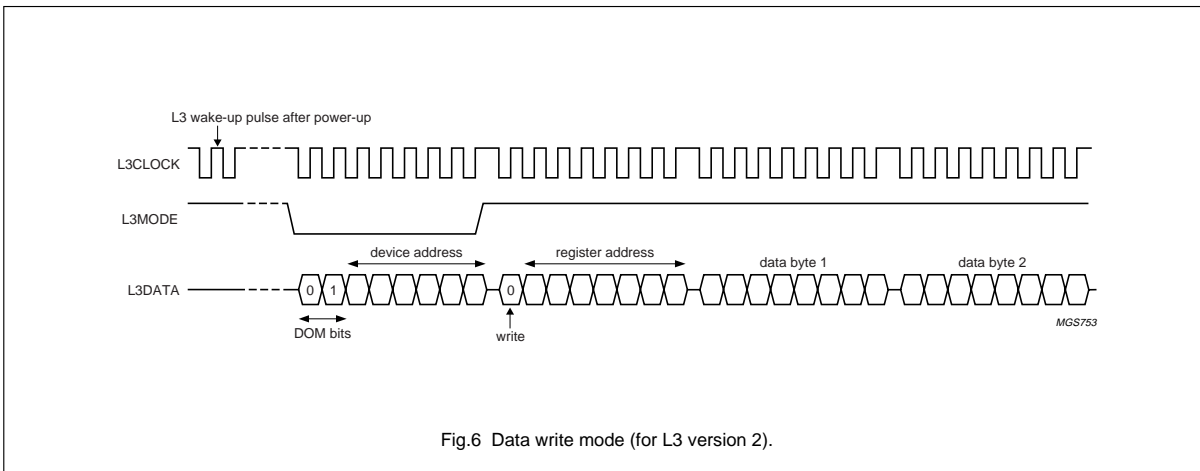

Fig.6 Data write mode (for L3 version 2).

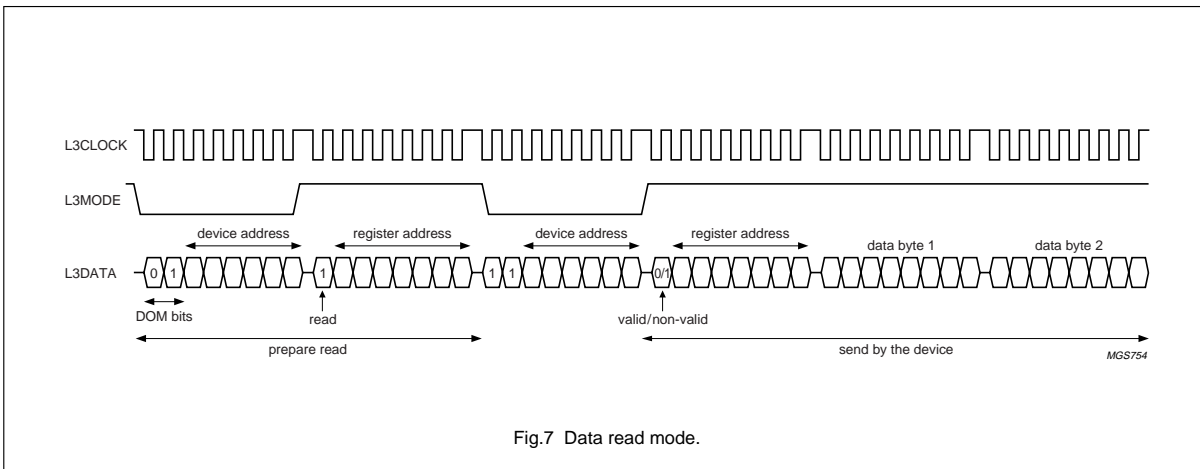

Fig.7 Data read mode.

IEC 958 audio DAC

UDA1350AH

8.7.4 DATA WRITE MODE

The data write mode is explained in the signal diagram of Fig.6. For writing data to a device, four bytes must be sent (see Table 6):

1. One byte starting with '01' for signalling the write action to the device, followed by the device address ('011000' for the UDA1350AH).
2. One byte starting with a '0' for signalling the write action, followed by 7 bits indicating the destination address in binary format with A6 being the MSB and A0 being the LSB.
3. Two data bytes with D15 being the MSB and D0 being the LSB.

It should be noted that each time a new destination register address needs to be written, the device address must be sent again.

8.7.5 DATA READ MODE

For reading data from the device, first a prepare read must be done and then data read. The data read mode is explained in the signal diagram of Fig.7.

For reading data from a device, the following six bytes are involved (see Table 7):

1. One byte with the device address including '01' for signalling the write action to the device.
2. One byte is sent with the register address from which data needs to be read. This byte starts with a '1', which indicates that there will be a read action from the register, followed again by 7 bits for the destination address in binary format with A6 being the MSB and A0 being the LSB.
3. One byte with the device address including '11' is sent to the device. The '11' indicates that the device must write data to the microcontroller.
4. One byte, sent by the device to the bus, with the (requested) register address and a flag bit indicating whether the requested register was valid (bit is logic 0) or invalid (bit is logic 1).
5. Two bytes, sent by the device to the bus, with the data information in binary format with D15 being the MSB and D0 being the LSB.

Table 6 L3 write data

BYTE	L3 MODE	ACTION	FIRST IN TIME				LATEST IN TIME			
			BIT 0	BIT 1	BIT 2	BIT 3	BIT 4	BIT 5	BIT 6	BIT 7
1	address	device address	0	1	0	1	1	0	0	0
2	data transfer	register address	0	A6	A5	A4	A3	A2	A1	A0
3	data transfer	data byte 1	D15	D14	D13	D12	D11	D10	D9	D8
4	data transfer	data byte 2	D7	D6	D5	D4	D3	D2	D1	D0

Table 7 L3 read data

BYTE	L3 MODE	ACTION	FIRST IN TIME				LATEST IN TIME			
			BIT 0	BIT 1	BIT 2	BIT 3	BIT 4	BIT 5	BIT 6	BIT 7
1	address	device address	0	1	0	1	1	0	0	0
2	data transfer	register address	1	A6	A5	A4	A3	A2	A1	A0
3	address	device address	1	1	0	1	1	0	0	0
4	data transfer	register address	0 or 1	A6	A5	A4	A3	A2	A1	A0
5	data transfer	data byte 1	D15	D14	D13	D12	D11	D10	D9	D8
6	data transfer	data byte 2	D7	D6	D5	D4	D3	D2	D1	D0

IEC 958 audio DAC

UDA1350AH

8.7.6 INITIALISATION STRING

For proper and reliable operation it is needed that the UDA1350AH is initialized in the L3 control mode. This is needed to have the PLL start up after power-up of the device under all conditions. The initialisation string is given in Table 8.

Table 8 L3 init string and set defaults after power-up.

BYTE	L3 MODE	ACTION		FIRST IN TIME					LATEST IN TIME		
				BIT 0	BIT 1	BIT 2	BIT 3	BIT 4	BIT 5	BIT 6	BIT 7
1	address	init string	device address	0	1	0	1	1	0	0	0
2	data transfer		register address	0	1	0	0	0	0	0	0
3	data transfer		data byte 1	0	0	0	0	0	0	0	0
4	data transfer		data byte 2	0	0	0	0	0	0	1	1
5	address	set defaults	device address	0	1	0	1	1	0	0	0
6	data transfer		register address	0	1	1	1	1	1	1	1
7	data transfer		data byte 1	0	0	0	0	0	0	0	0
8	data transfer		data byte 2	0	0	0	0	0	0	0	0

IEC 958 audio DAC

UDA1350AH

8.7.7 OVERVIEW OF L3 INTERFACE REGISTERS

Table 9 UDA1350AH register map

ADDR	FUNCTION	BIT															
		D15	D14	D13	D12	D11	D10	D9	D8	D7	D6	D5	D4	D3	D2	D1	D0
Writable settings																	
00H	system parameters				PON			CHAN sel	IIS sel			SPD sel		SFOR1	SFOR0		
	default			1			0	0			1		0	0			
10H	sound features			M1	M0	BB3	BB2	BB1	BB0				TR1	TR0	DE1	DE0	MT
	default			0	0	0	0	0	0				0	0	0	0	1
11H	volume control DAC											VC5	VC4	VC3	VC2	VC1	VC0
	default										0	0	0	0	0	0	
40H	multiplex parameters															Auto MT	RST PLL
	default										0 ⁽¹⁾	0 ⁽¹⁾	0 ⁽¹⁾	0 ⁽¹⁾	1		
7FH	restore L3 defaults																
Readable settings																	
18H	interpolator parameters																MT stat
38H	SPDIF input and lock parameters						PLL lock		SPD lock	ASF1	ASF0	PCM stat		PRE		ACC1	ACC0

Note

- When writing new settings via the L3 interface, these bits should always remain logic 0 (default value) to warrant correct operation.

IEC 958 audio DAC

UDA1350AH

8.7.8 WRITABLE REGISTERS

8.7.8.1 Restoring L3 defaults

By writing to the 7FH register, all L3 control values are restored to their default values. Only the L3 interface is affected, the system will not be reset. Consequently readable registers, which are not reset, can be affected.

8.7.8.2 Power-on

A 1-bit value to switch the DAC on and off.

Table 10 Power-on setting

PON	FUNCTION
0	power-down
1	power-on (default setting)

8.7.8.3 Slicer input selection

A 1-bit value to select an IEC 958 input channel.

Table 11 Slicer input selection

CHAN sel	FUNCTION
0	IEC 958 input from pin SPDIF0 (default setting)
1	IEC 958 input from pin SPDIF1

8.7.8.4 Clock source selection

A 1-bit value to select the source for clock regeneration, either from the IEC 958 input or digital data input interface. In the event that the IEC 958 input is used as a clock source the UDA1350AH is clock master on the digital data output and input interfaces.

Table 12 Clock source selection

IIS sel	FUNCTION
0	slave to audio sampling frequency of IEC 958 input (default setting)
1	slave to audio sampling frequency of digital data input interface

8.7.8.5 DAC input selection

A 1-bit value to select the data source, either the IEC 958 input or the digital data input interface.

Table 13 DAC input selection

SPD sel	FUNCTION
0	input from data input interface
1	input from IEC 958 (default setting)

8.7.8.6 Serial format selection

A 2-bit value to set the serial format for the digital data output and input interfaces.

Table 14 Serial format settings

SFOR1	SFOR0	FUNCTION
0	0	I ² S-bus (default settings)
0	1	LSB-justified, 16 bits
1	0	LSB-justified, 20 bits
1	1	LSB-justified, 24 bits

8.7.8.7 Filter mode selection

A 2-bit value to program the mode for the sound processing filters of bass boost and treble.

Table 15 Filter mode settings

M1	M0	FUNCTION
0	0	flat (default setting)
0	1	minimum
1	0	
1	1	maximum

8.7.8.8 Treble

A 2-bit value to program the treble setting in combination with the filter mode settings. At $f_s = 44.1$ kHz the -3 dB point for minimum setting is 3.0 kHz and the -3 dB point for maximum setting is 1.5 kHz. The default value is '00'.

Table 16 Treble settings

TR1	TR0	LEVEL		
		FLAT (dB)	MIN. (dB)	MAX. (dB)
0	0	0	0	0
0	1	0	2	2
1	0	0	4	4
1	1	0	6	6

IEC 958 audio DAC

UDA1350AH

8.7.8.9 Bass boost

A 4-bit value to program the bass boost setting in combination with the filter mode settings. At $f_s = 44.1$ kHz the -3 dB point for minimum setting is 250 Hz and the -3 dB point for maximum setting is 300 Hz. The default value is '0000'.

Table 17 Bass boost settings

BB3	BB2	BB1	BB0	LEVEL		
				FLAT (dB)	MIN. (dB)	MAX. (dB)
0	0	0	0	0	0	0
0	0	0	1	0	2	2
0	0	1	0	0	4	4
0	0	1	1	0	6	6
0	1	0	0	0	8	8
0	1	0	1	0	10	10
0	1	1	0	0	12	12
0	1	1	1	0	14	14
1	0	0	0	0	16	16
1	0	0	1	0	18	18
1	0	1	0	0	18	20
1	0	1	1	0	18	22
1	1	0	0	0	18	24
1	1	0	1	0	18	24
1	1	1	0	0	18	24
1	1	1	1	0	18	24

8.7.8.10 De-emphasis

A 2-bit value to enable the digital de-emphasis filter.

Table 18 De-emphasis selection

DE1	DE0	FUNCTION
0	0	other (default setting)
0	1	$f_s = 32.0$ kHz
1	0	$f_s = 44.1$ kHz
1	1	$f_s = 48.0$ kHz

8.7.8.11 Soft mute

A 1-bit value to enable the digital mute.

Table 19 Soft mute selection

MT	FUNCTION
0	no muting
1	muting (default setting)

8.7.8.12 Volume control

A 6-bit value to program the left and right channel volume attenuation. The range is from 0 to $-\infty$ dB in steps of 1 dB.

Table 20 Volume settings interpolator core

VC5	VC4	VC3	VC2	VC1	VC0	VOLUME (dB)
0	0	0	0	0	0	0
0	0	0	0	0	1	0
0	0	0	0	1	0	-1
0	0	0	0	1	1	-2
:	:	:	:	:	:	:
1	1	1	0	1	1	-58
1	1	1	1	0	0	-59
1	1	1	1	0	1	-60
1	1	1	1	1	0	$-\infty$
1	1	1	1	1	1	$-\infty$

8.7.8.13 Auto mute

A 1-bit value to activate mute during out-of-lock. In normal operation the output is automatically hard muted when an out-of-lock situation is detected. Setting this bit to logic 0 will disable that function.

Table 21 Auto mute setting

Auto MT	FUNCTION
0	do not mute output during out-of-lock
1	mute output during out-of-lock (default setting)

IEC 958 audio DAC

UDA1350AH

8.7.8.14 PLL reset

A 1-bit value to reset the PLL. This is the bit which is set in the initialisation string. When this bit is asserted, the PLL will be reset and the output clock of the PLL will be forced to its lowest value, which is in the area of a few MHz.

Table 22 PLL reset

RST PLL	FUNCTION
0	normal operation
1	PLL is reset

8.7.9 READABLE REGISTERS**8.7.9.1 Mute status**

A 1-bit value indicating whether the interpolator is muting or not muting.

Table 23 Interpolator mute status

MT stat	FUNCTION
0	no muting
1	muting

8.7.9.2 PLL lock detection

A 1-bit value indicating that the clock regeneration is locked.

Table 24 PLL lock indication

PLL lock	FUNCTION
0	out-of-lock
1	locked

8.7.9.3 SPDIF lock detection

A 1-bit value indicating the IEC 958 decoder is locked and is decoding correct data.

Table 25 SPDIF lock detection

SPD lock	FUNCTION
0	not locked or non-PCM data detected
1	locked and PCM data detected

8.7.9.4 Audio sample frequency detection

A 2-bit value indicating the audio sample frequency of the IEC 958 input signal.

Table 26 Audio sample frequency detection

ASF1	ASF0	FUNCTION
0	0	44.1 kHz
0	1	undefined
1	0	48.0 kHz
1	1	32.0 kHz

8.7.9.5 PCM detection

A 1-bit value which indicates whether the IEC 958 input contains PCM audio data or other binary data.

Table 27 Two channel PCM input detection

PCM stat	FUNCTION
0	input with two channel PCM data
1	input without two channel PCM data

8.7.9.6 Pre-emphasis detection

A 1-bit value which indicates whether the pre-emphasis bit was set on the IEC 958 input signal or not set.

Table 28 Pre-emphasis detection

PRE	FUNCTION
0	no pre-emphasis
1	pre-emphasis

8.7.9.7 Clock accuracy detection

A 2-bit value indicating the timing accuracy of the IEC 958 input signal is conforming to the IEC 958 specification.

Table 29 Input signal accuracy detection

ACC1	ACC0	FUNCTION
0	0	level II
0	1	level I
1	0	level III
1	1	undefined

IEC 958 audio DAC

UDA1350AH

9 LIMITING VALUES

In accordance with the Absolute Maximum Rating System (IEC 134).

SYMBOL	PARAMETER	CONDITIONS	MIN.	MAX.	UNIT
V_{DD}	supply voltage	note 1	2.7	5.0	V
T_{xtal}	crystal temperature		-25	+150	°C
T_{stg}	storage temperature		-65	+125	°C
T_{amb}	ambient temperature		-40	+85	°C
V_{es}	electrostatic handling voltage	Human Body Model (HBM); note 2	-2000	+2000	V
		Machine Model (MM)	-200	+200	V
$I_{lu(prot)}$	latch-up protection current	note 3	-	200	mA
$I_{sc(DAC)}$	short-circuit current of DAC	note 4			
		output short-circuited to $V_{SSA(DAC)}$	-	482	mA
		output short-circuited to $V_{DDA(DAC)}$	-	346	mA

Notes

1. All V_{DD} and V_{SS} connections must be made to the same power supply.
2. JEDEC class 2 compliant, except pin $V_{SSA(PLL)}$ which can withstand ESD pulses of -1600 to +1600 V.
3. Latch-up test at $T_{amb} = 125$ °C and $V_{DD} = 3.6$ V.
4. Short-circuit test at $T_{amb} = 0$ °C and $V_{DD} = 3$ V. DAC operation after short-circuiting cannot be warranted.

10 THERMAL CHARACTERISTICS

SYMBOL	PARAMETER	CONDITIONS	VALUE	UNIT
$R_{th(j-a)}$	thermal resistance from junction to ambient	in free air	63	K/W

IEC 958 audio DAC

UDA1350AH

11 CHARACTERISTICS

$V_{DDD} = V_{DDA} = 3.0$ V; IEC 958 input with $f_s = 48.0$ kHz; $T_{amb} = 25$ °C; $R_L = 5$ k Ω ; all voltages measured with respect to ground; unless otherwise specified.

SYMBOL	PARAMETER	CONDITIONS	MIN.	TYP.	MAX.	UNIT
Supplies; note 1						
V_{DDA}	analog supply voltage		2.7	3.0	3.6	V
$V_{DDA(DAC)}$	analog supply voltage for DAC		2.7	3.0	3.6	V
$V_{DDA(PLL)}$	analog supply voltage for PLL		2.7	3.0	3.6	V
V_{DDD}	digital supply voltage		2.7	3.0	3.6	V
$V_{DDD(C)}$	digital supply voltage for core		2.7	3.0	3.6	V
$I_{DDA(DAC)}$	analog supply current of DAC	power-on	–	8.0	–	mA
		power-down	–	750	–	μ A
$I_{DDA(PLL)}$	analog supply current of PLL		–	0.7	–	mA
I_{DDD}	digital supply current		–	2.0	–	mA
$I_{DDD(C)}$	digital supply current of core		–	16.0	–	mA
P	power dissipation	DAC in playback mode	–	80	–	mW
		DAC in Power-down mode	–	58	–	mW
Digital input pins						
V_{IH}	HIGH-level input voltage		$0.8V_{DD}$	–	$V_{DD} + 0.5$	V
V_{IL}	LOW-level input voltage		–0.5	–	$+0.2V_{DD}$	V
$V_{hys(RESET)}$	hysteresis voltage on pin RESET		–	0.8	–	V
$ I_{LI} $	input leakage current		–	–	10	μ A
C_i	input capacitance		–	–	10	pF
$R_{pu(int)}$	internal pull-up resistance		16	33	78	k Ω
$R_{pd(int)}$	internal pull-down resistance		16	33	78	k Ω
Digital output pins						
V_{OH}	HIGH-level output voltage	$I_{OH} = -2$ mA	$0.85V_{DD}$	–	–	V
V_{OL}	LOW-level output voltage	$I_{OL} = 2$ mA	–	–	0.4	V
$I_{L(max)}$	maximum load current		–	3	–	mA
Digital-to-analog converter; note 2						
V_{ref}	reference voltage	measured with respect to V_{SSA}	$0.45V_{DDA}$	$0.50V_{DDA}$	$0.55V_{DDA}$	V
$V_{o(rms)}$	output voltage (RMS value)	note 3	–	900	–	mV
(THD + N)/S	total harmonic distortion-plus-noise to signal ratio	$f_i = 1.0$ kHz tone at 0 dB	–	–90	–85	dB
		at –40 dB; A-weighted	–	–60	–55	dB
S/N	signal-to-noise ratio	$f_i = 1.0$ kHz tone; code = 0; A-weighted	95	100	–	dB
α_{cs}	channel separation	$f_i = 1.0$ kHz tone	–	96	–	dB
ΔV_o	unbalance of output voltages	$f_i = 1.0$ kHz tone	–	0.1	0.4	dB

IEC 958 audio DAC

UDA1350AH

SYMBOL	PARAMETER	CONDITIONS	MIN.	TYP.	MAX.	UNIT
IEC 958 inputs						
$V_{i(p-p)}$	AC input voltage (peak-to-peak value)		0.2	0.5	3.3	V
R_i	input resistance		–	6	–	k Ω
V_{hys}	hysteresis voltage		–	40	–	mV

Notes

- All supply pins V_{DD} and V_{SS} must be connected to the same external power supply unit.
- When the DAC must drive a higher capacitive load (above 50 pF), then a series resistor of 100 Ω must be used in order to prevent oscillations in the output stage of the operational amplifier.
- The output voltage of the DAC is proportional to the DAC power supply voltage.

12 TIMING CHARACTERISTICS

$V_{DDD} = V_{DDA} = 2.7$ to 3.6 V; $T_{amb} = -40$ to $+85$ °C; $R_L = 5$ k Ω ; all voltages measured with respect to ground; unless otherwise specified.

SYMBOL	PARAMETER	CONDITIONS	MIN.	TYP.	MAX.	UNIT
Device reset						
t_{rst}	reset active time		–	250	–	μ s
PLL lock time						
t_{lock}	time to lock	$f_s = 32.0$ kHz	–	97.0	–	ms
		$f_s = 44.1$ kHz	–	91.0	–	ms
		$f_s = 48.0$ kHz	–	90.0	–	ms
I²S-bus timing (see Fig.8)						
$T_{cy(BCK)}$	bit clock cycle time	$T_s =$ cycle time of sample frequency	–	–	$\frac{1}{64}T_s$	s
t_{BCKH}	bit clock HIGH time		140	–	280	ns
t_{BCKL}	bit clock LOW time		140	–	280	ns
t_r	rise time		–	–	20	ns
t_f	fall time		–	–	20	ns
$t_{su(WS)}$	set-up time word select		20	–	–	ns
$t_{h(WS)}$	hold time word select		10	–	–	ns
$t_{su(DATAI)}$	set-up time data input		20	–	–	ns
$t_{h(DATAI)}$	hold time data input		0	–	–	ns
$t_{h(DATAO)}$	hold time data output		0	–	–	ns
$t_d(DATAO-BCK)$	data output to bit clock delay		–	–	80	ns
$t_d(DATAO-WS)$	data output to word select delay		–	–	80	ns

IEC 958 audio DAC

UDA1350AH

SYMBOL	PARAMETER	CONDITIONS	MIN.	TYP.	MAX.	UNIT
Microcontroller L3 interface timing (see Figs 9 and 10)						
$T_{cy(CLK)(L3)}$	L3CLOCK cycle time		500	–	–	ns
$t_{CLK(L3)H}$	L3CLOCK HIGH time		250	–	–	ns
$t_{CLK(L3)L}$	L3CLOCK LOW time		250	–	–	ns
$t_{su(L3)A}$	L3MODE set-up time in address mode		190	–	–	ns
$t_{h(L3)A}$	L3MODE hold time in address mode		190	–	–	ns
$t_{su(L3)D}$	L3MODE set-up time in data transfer mode		190	–	–	ns
$t_{h(L3)D}$	L3MODE hold time in data transfer mode		190	–	–	ns
$t_{(stp)(L3)}$	L3MODE stop time in data transfer mode		190	–	–	ns
$t_{su(L3)DA}$	L3DATA set-up time in address and data transfer mode		190	–	–	ns
$t_{h(L3)DA}$	L3DATA hold time in address and data transfer mode		30	–	–	ns

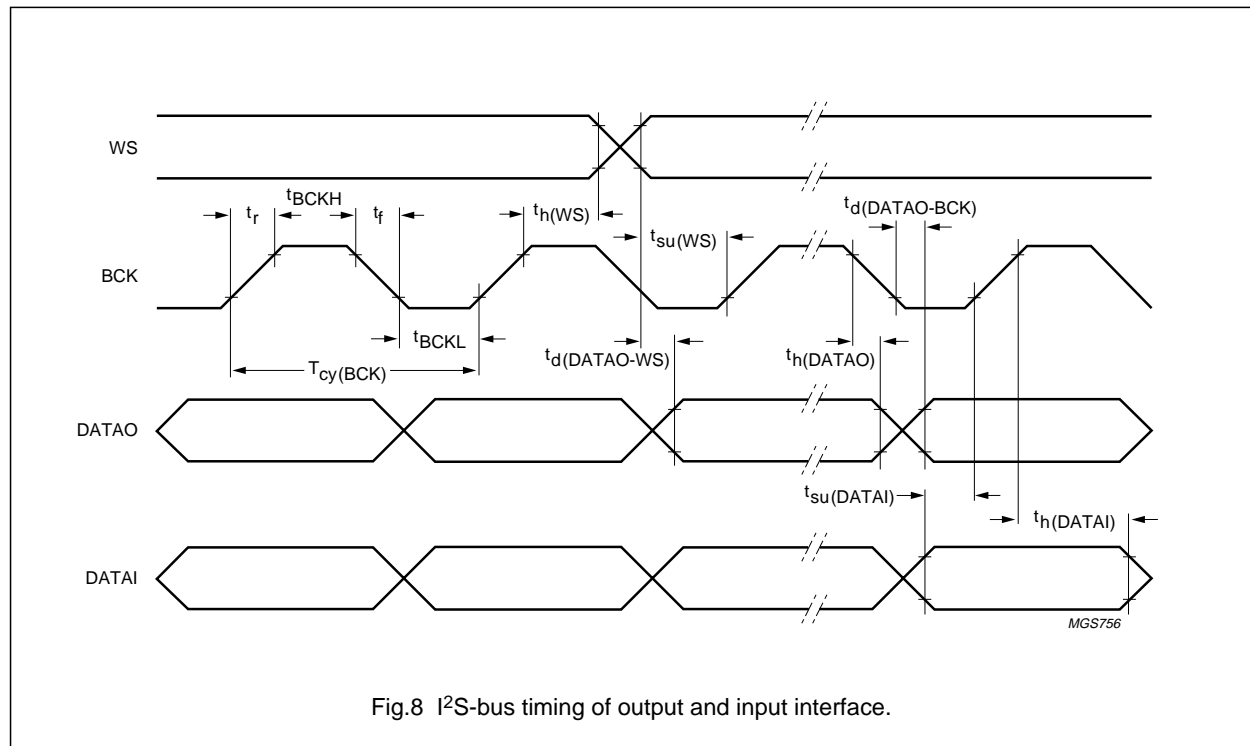

Fig.8 I²S-bus timing of output and input interface.

IEC 958 audio DAC

UDA1350AH

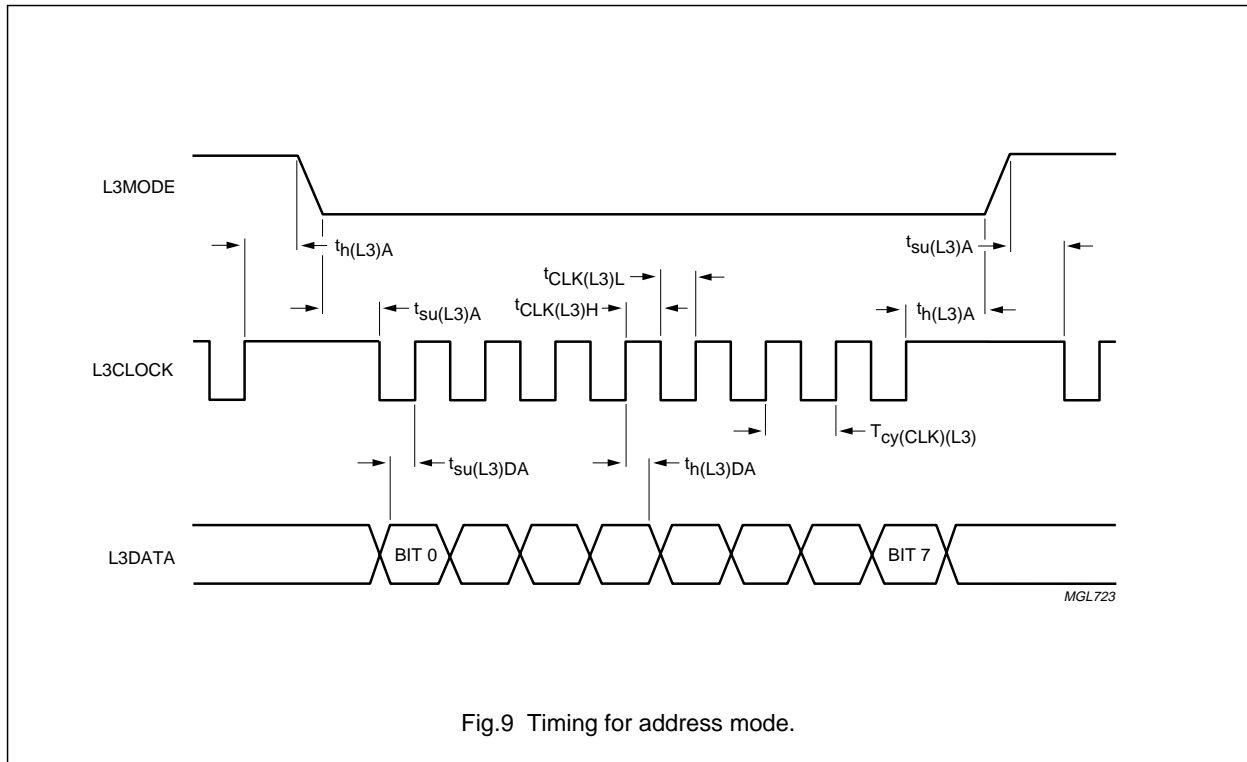

Fig.9 Timing for address mode.

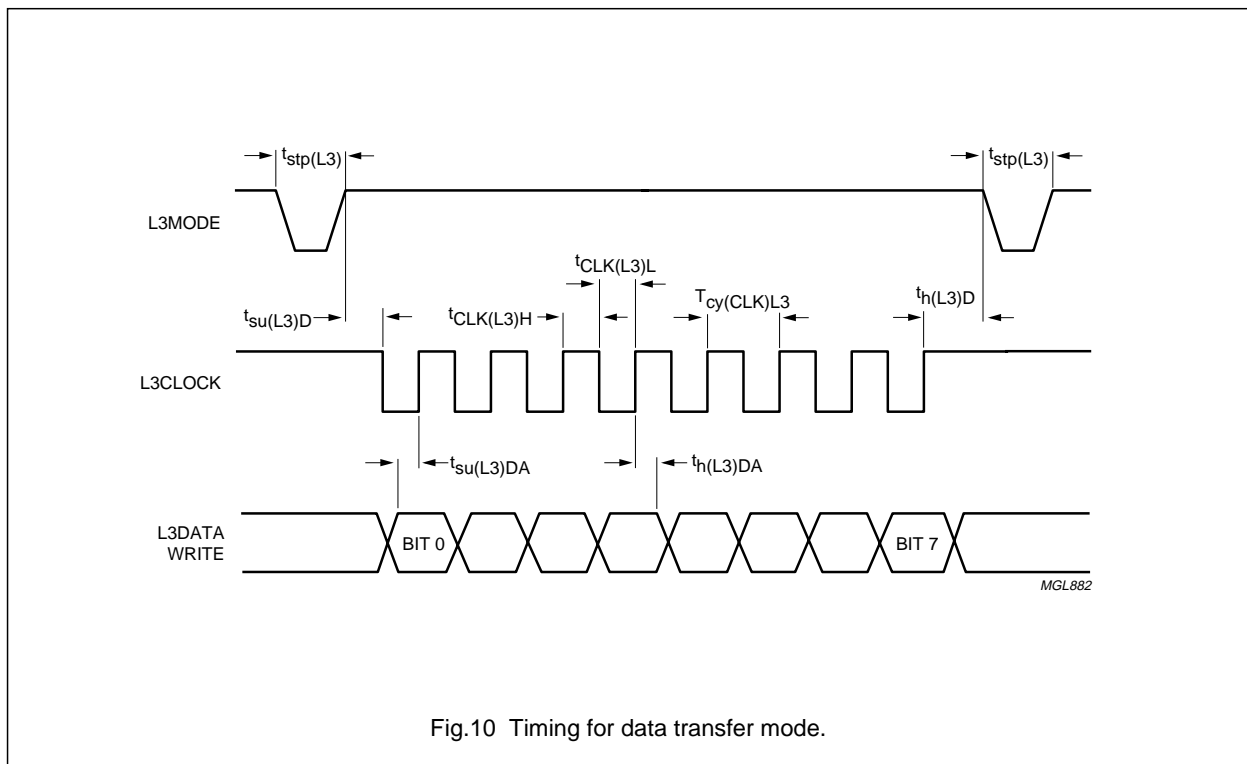
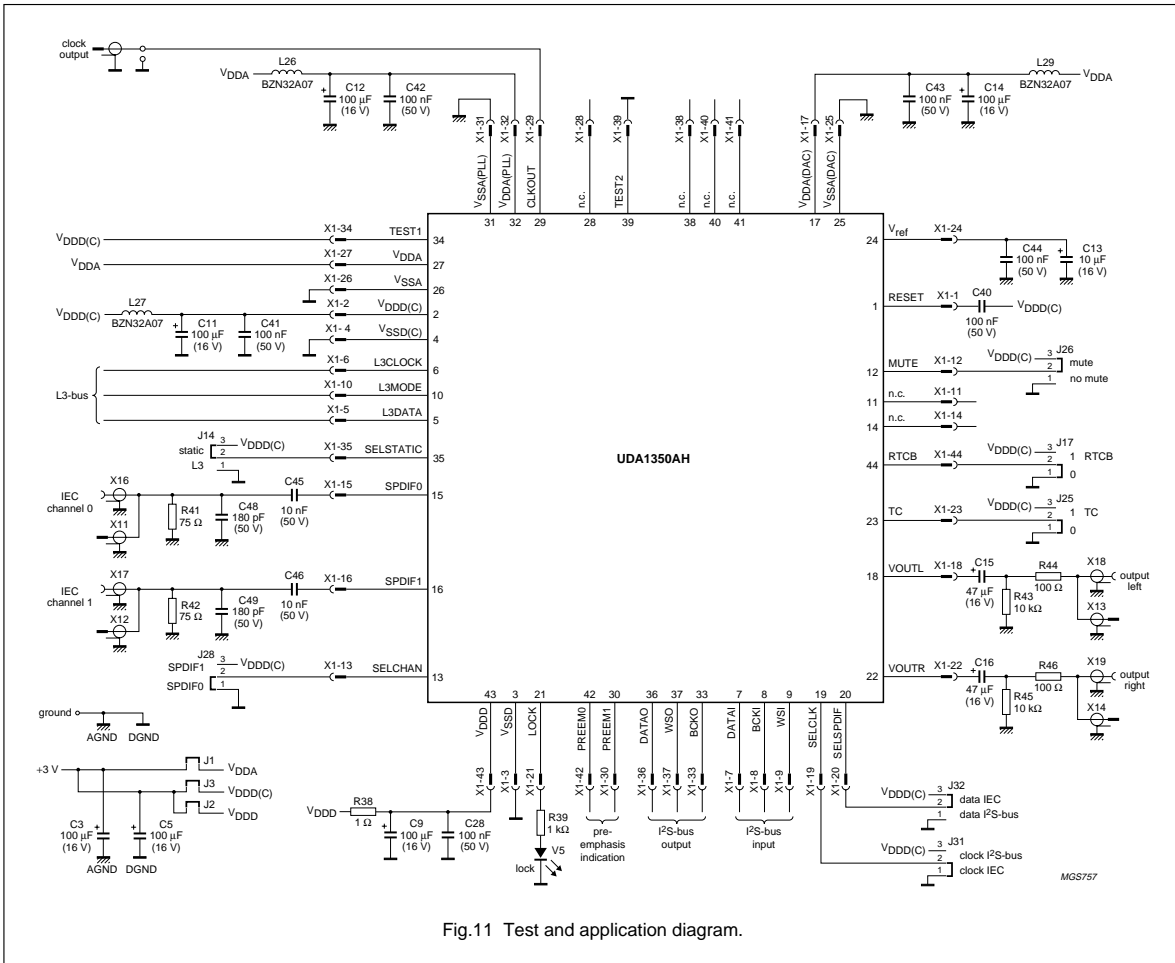

Fig.10 Timing for data transfer mode.

IEC 958 audio DAC

UDA1350AH

13 APPLICATION INFORMATION



IEC 958 audio DAC

UDA1350AH

14 PACKAGE OUTLINE

QFP44: plastic quad flat package; 44 leads (lead length 1.3 mm); body 10 x 10 x 1.75 mm

SOT307-2

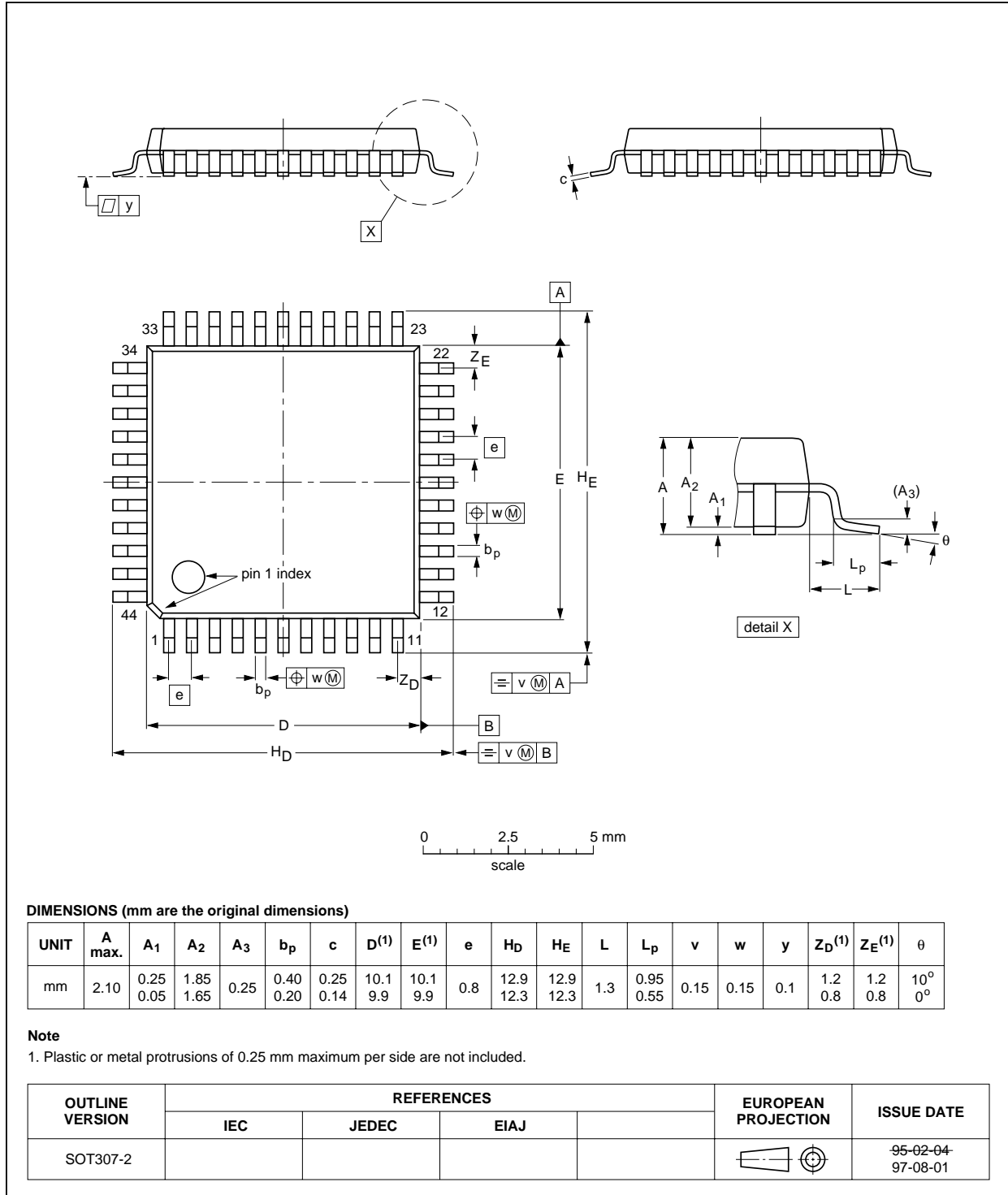

IEC 958 audio DAC

UDA1350AH

15 SOLDERING**15.1 Introduction to soldering surface mount packages**

This text gives a very brief insight to a complex technology. A more in-depth account of soldering ICs can be found in our "Data Handbook IC26; Integrated Circuit Packages" (document order number 9398 652 90011).

There is no soldering method that is ideal for all surface mount IC packages. Wave soldering is not always suitable for surface mount ICs, or for printed-circuit boards with high population densities. In these situations reflow soldering is often used.

15.2 Reflow soldering

Reflow soldering requires solder paste (a suspension of fine solder particles, flux and binding agent) to be applied to the printed-circuit board by screen printing, stencilling or pressure-syringe dispensing before package placement.

Several methods exist for reflowing; for example, infrared/convection heating in a conveyor type oven. Throughput times (preheating, soldering and cooling) vary between 100 and 200 seconds depending on heating method.

Typical reflow peak temperatures range from 215 to 250 °C. The top-surface temperature of the packages should preferably be kept below 230 °C.

15.3 Wave soldering

Conventional single wave soldering is not recommended for surface mount devices (SMDs) or printed-circuit boards with a high component density, as solder bridging and non-wetting can present major problems.

To overcome these problems the double-wave soldering method was specifically developed.

If wave soldering is used the following conditions must be observed for optimal results:

- Use a double-wave soldering method comprising a turbulent wave with high upward pressure followed by a smooth laminar wave.
- For packages with leads on two sides and a pitch (e):
 - larger than or equal to 1.27 mm, the footprint longitudinal axis is **preferred** to be parallel to the transport direction of the printed-circuit board;
 - smaller than 1.27 mm, the footprint longitudinal axis **must** be parallel to the transport direction of the printed-circuit board.

The footprint must incorporate solder thieves at the downstream end.

- For packages with leads on four sides, the footprint must be placed at a 45° angle to the transport direction of the printed-circuit board. The footprint must incorporate solder thieves downstream and at the side corners.

During placement and before soldering, the package must be fixed with a droplet of adhesive. The adhesive can be applied by screen printing, pin transfer or syringe dispensing. The package can be soldered after the adhesive is cured.

Typical dwell time is 4 seconds at 250 °C.

A mildly-activated flux will eliminate the need for removal of corrosive residues in most applications.

15.4 Manual soldering

Fix the component by first soldering two diagonally-opposite end leads. Use a low voltage (24 V or less) soldering iron applied to the flat part of the lead. Contact time must be limited to 10 seconds at up to 300 °C.

When using a dedicated tool, all other leads can be soldered in one operation within 2 to 5 seconds between 270 and 320 °C.

IEC 958 audio DAC

UDA1350AH

15.5 Suitability of surface mount IC packages for wave and reflow soldering methods

PACKAGE	SOLDERING METHOD	
	WAVE	REFLOW ⁽¹⁾
BGA, SQFP	not suitable	suitable
HLQFP, HSQFP, HSOP, HTQFP, HTSSOP, SMS	not suitable ⁽²⁾	suitable
PLCC ⁽³⁾ , SO, SOJ	suitable	suitable
LQFP, QFP, TQFP	not recommended ⁽³⁾⁽⁴⁾	suitable
SSOP, TSSOP, VSO	not recommended ⁽⁵⁾	suitable

Notes

1. All surface mount (SMD) packages are moisture sensitive. Depending upon the moisture content, the maximum temperature (with respect to time) and body size of the package, there is a risk that internal or external package cracks may occur due to vaporization of the moisture in them (the so called popcorn effect). For details, refer to the Drypack information in the "Data Handbook IC26; Integrated Circuit Packages; Section: Packing Methods".
2. These packages are not suitable for wave soldering as a solder joint between the printed-circuit board and heatsink (at bottom version) can not be achieved, and as solder may stick to the heatsink (on top version).
3. If wave soldering is considered, then the package must be placed at a 45° angle to the solder wave direction. The package footprint must incorporate solder thieves downstream and at the side corners.
4. Wave soldering is only suitable for LQFP, TQFP and QFP packages with a pitch (e) equal to or larger than 0.8 mm; it is definitely not suitable for packages with a pitch (e) equal to or smaller than 0.65 mm.
5. Wave soldering is only suitable for SSOP and TSSOP packages with a pitch (e) equal to or larger than 0.65 mm; it is definitely not suitable for packages with a pitch (e) equal to or smaller than 0.5 mm.

16 DEFINITIONS

Data sheet status	
Objective specification	This data sheet contains target or goal specifications for product development.
Preliminary specification	This data sheet contains preliminary data; supplementary data may be published later.
Product specification	This data sheet contains final product specifications.
Limiting values	
Limiting values given are in accordance with the Absolute Maximum Rating System (IEC 134). Stress above one or more of the limiting values may cause permanent damage to the device. These are stress ratings only and operation of the device at these or at any other conditions above those given in the Characteristics sections of the specification is not implied. Exposure to limiting values for extended periods may affect device reliability.	
Application information	
Where application information is given, it is advisory and does not form part of the specification.	

17 LIFE SUPPORT APPLICATIONS

These products are not designed for use in life support appliances, devices, or systems where malfunction of these products can reasonably be expected to result in personal injury. Philips customers using or selling these products for use in such applications do so at their own risk and agree to fully indemnify Philips for any damages resulting from such improper use or sale.

IEC 958 audio DAC

UDA1350AH

NOTES

IEC 958 audio DAC

UDA1350AH

NOTES

IEC 958 audio DAC

UDA1350AH

NOTES

Philips Semiconductors – a worldwide company

Argentina: see South America

Australia: 3 Figtree Drive, HOMEBUSH, NSW 2140,
Tel. +61 2 9704 8141, Fax. +61 2 9704 8139

Austria: Computerstr. 6, A-1101 WIEN, P.O. Box 213,
Tel. +43 1 60 101 1248, Fax. +43 1 60 101 1210

Belarus: Hotel Minsk Business Center, Bld. 3, r. 1211, Volodarski Str. 6,
220050 MINSK, Tel. +375 172 20 0733, Fax. +375 172 20 0773

Belgium: see The Netherlands

Brazil: see South America

Bulgaria: Philips Bulgaria Ltd., Energoproject, 15th floor,
51 James Bourchier Blvd., 1407 SOFIA,
Tel. +359 2 68 9211, Fax. +359 2 68 9102

Canada: PHILIPS SEMICONDUCTORS/COMPONENTS,
Tel. +1 800 234 7381, Fax. +1 800 943 0087

China/Hong Kong: 501 Hong Kong Industrial Technology Centre,
72 Tat Chee Avenue, Kowloon Tong, HONG KONG,
Tel. +852 2319 7888, Fax. +852 2319 7700

Colombia: see South America

Czech Republic: see Austria

Denmark: Sydhavnsgade 23, 1780 COPENHAGEN V,
Tel. +45 33 29 3333, Fax. +45 33 29 3905

Finland: Sinikalliontie 3, FIN-02630 ESPOO,
Tel. +358 9 615 800, Fax. +358 9 6158 0920

France: 51 Rue Carnot, BP317, 92156 SURESNES Cedex,
Tel. +33 1 4099 6161, Fax. +33 1 4099 6427

Germany: Hammerbrookstraße 69, D-20097 HAMBURG,
Tel. +49 40 2353 60, Fax. +49 40 2353 6300

Hungary: see Austria

India: Philips INDIA Ltd, Band Box Building, 2nd floor,
254-D, Dr. Annie Besant Road, Worli, MUMBAI 400 025,
Tel. +91 22 493 8541, Fax. +91 22 493 0966

Indonesia: PT Philips Development Corporation, Semiconductors Division,
Gedung Philips, Jl. Buncit Raya Kav.99-100, JAKARTA 12510,
Tel. +62 21 794 0040 ext. 2501, Fax. +62 21 794 0080

Ireland: Newstead, Clonskeagh, DUBLIN 14,
Tel. +353 1 7640 000, Fax. +353 1 7640 200

Israel: RAPAC Electronics, 7 Kehilat Saloniki St, PO Box 18053,
TEL AVIV 61180, Tel. +972 3 645 0444, Fax. +972 3 649 1007

Italy: PHILIPS SEMICONDUCTORS, Via Casati, 23 - 20052 MONZA (MI),
Tel. +39 039 203 6838, Fax. +39 039 203 6800

Japan: Philips Bldg 13-37, Kohnan 2-chome, Minato-ku,
TOKYO 108-8507, Tel. +81 3 3740 5130, Fax. +81 3 3740 5057

Korea: Philips House, 260-199 Itaewon-dong, Yongsan-ku, SEOUL,
Tel. +82 2 709 1412, Fax. +82 2 709 1415

Malaysia: No. 76 Jalan Universiti, 46200 PETALING JAYA, SELANGOR,
Tel. +60 3 750 5214, Fax. +60 3 757 4880

Mexico: 5900 Gateway East, Suite 200, EL PASO, TEXAS 79905,
Tel. +9-5 800 234 7381, Fax. +9-5 800 943 0087

Middle East: see Italy

Netherlands: Postbus 90050, 5600 PB EINDHOVEN, Bldg. VB,
Tel. +31 40 27 82785, Fax. +31 40 27 88399

New Zealand: 2 Wagener Place, C.P.O. Box 1041, AUCKLAND,
Tel. +64 9 849 4160, Fax. +64 9 849 7811

Norway: Box 1, Manglerud 0612, OSLO,
Tel. +47 22 74 8000, Fax. +47 22 74 8341

Pakistan: see Singapore

Philippines: Philips Semiconductors Philippines Inc.,
106 Valero St. Salcedo Village, P.O. Box 2108 MCC, MAKATI,
Metro MANILA, Tel. +63 2 816 6380, Fax. +63 2 817 3474

Poland: Al.Jerozolimskie 195 B, 02-222 WARSAW,
Tel. +48 22 5710 000, Fax. +48 22 5710 001

Portugal: see Spain

Romania: see Italy

Russia: Philips Russia, Ul. Usatcheva 35A, 119048 MOSCOW,
Tel. +7 095 755 6918, Fax. +7 095 755 6919

Singapore: Lorong 1, Toa Payoh, SINGAPORE 319762,
Tel. +65 350 2538, Fax. +65 251 6500

Slovakia: see Austria

Slovenia: see Italy

South Africa: S.A. PHILIPS Pty Ltd., 195-215 Main Road Martindale,
2092 JOHANNESBURG, P.O. Box 58088 Newville 2114,
Tel. +27 11 471 5401, Fax. +27 11 471 5398

South America: Al. Vicente Pinzon, 173, 6th floor,
04547-130 SÃO PAULO, SP, Brazil,
Tel. +55 11 821 2333, Fax. +55 11 821 2382

Spain: Balmes 22, 08007 BARCELONA,
Tel. +34 93 301 6312, Fax. +34 93 301 4107

Sweden: Kottbygatan 7, Akalla, S-16485 STOCKHOLM,
Tel. +46 8 5985 2000, Fax. +46 8 5985 2745

Switzerland: Allmendstrasse 140, CH-8027 ZÜRICH,
Tel. +41 1 488 2741 Fax. +41 1 488 3263

Taiwan: Philips Semiconductors, 6F, No. 96, Chien Kuo N. Rd., Sec. 1,
TAIPEI, Taiwan Tel. +886 2 2134 2886, Fax. +886 2 2134 2874

Thailand: PHILIPS ELECTRONICS (THAILAND) Ltd.,
209/2 Sanpavuth-Bangna Road Prakanong, BANGKOK 10260,
Tel. +66 2 745 4090, Fax. +66 2 398 0793

Turkey: Yukari Dudullu, Org. San. Blg., 2.Cad. Nr. 28 81260 Umraniye,
ISTANBUL, Tel. +90 216 522 1500, Fax. +90 216 522 1813

Ukraine: PHILIPS UKRAINE, 4 Patrice Lumumba str., Building B, Floor 7,
252042 KIEV, Tel. +380 44 264 2776, Fax. +380 44 268 0461

United Kingdom: Philips Semiconductors Ltd., 276 Bath Road, Hayes,
MIDDLESEX UB3 5BX, Tel. +44 208 730 5000, Fax. +44 208 754 8421

United States: 811 East Arques Avenue, SUNNYVALE, CA 94088-3409,
Tel. +1 800 234 7381, Fax. +1 800 943 0087

Uruguay: see South America

Vietnam: see Singapore

Yugoslavia: PHILIPS, Trg N. Pasicca 5/v, 11000 BEOGRAD,
Tel. +381 11 62 5344, Fax. +381 11 63 5777

For all other countries apply to: Philips Semiconductors,
International Marketing & Sales Communications, Building BE-p, P.O. Box 218,
5600 MD EINDHOVEN, The Netherlands, Fax. +31 40 27 24825

Internet: <http://www.semiconductors.philips.com>

© Philips Electronics N.V. 1999

SCA 68

All rights are reserved. Reproduction in whole or in part is prohibited without the prior written consent of the copyright owner.

The information presented in this document does not form part of any quotation or contract, is believed to be accurate and reliable and may be changed without notice. No liability will be accepted by the publisher for any consequence of its use. Publication thereof does not convey nor imply any license under patent- or other industrial or intellectual property rights.

Printed in The Netherlands

545002/25/01/pp36

Date of release: 1999 Dec 16

Document order number: 9397 750 05999

Let's make things better.

Philips
Semiconductors



PHILIPS