

# MC3458 MC3358

## Dual, Low Power Operational Amplifiers

Utilizing the circuit designs perfected for the quad operational amplifiers, these dual operational amplifiers feature: 1) low power drain, 2) a common mode input voltage range extending to ground/ $V_{EE}$ , and 3) Single Supply or Split Supply operation.

These amplifiers have several distinct advantages over standard operational amplifier types in single supply applications. They can operate at supply voltages as low as 3.0 V or as high as 36 V with quiescent currents about one-fifth of those associated with the MC1741C (on a per amplifier basis). The common mode input range includes the negative supply, thereby eliminating the necessity for external biasing components in many applications. The output voltage range also includes the negative power supply voltage.

- Short Circuit Protected Outputs
- True Differential Input Stage
- Single Supply Operation: 3.0 V to 36 V
- Low Input Bias Currents
- Internally Compensated
- Common Mode Range Extends to Negative Supply
- Class AB Output Stage for Minimum Crossover Distortion
- Single and Split Supply Operations Available
- Similar Performance to the Popular MC1458

### DUAL DIFFERENTIAL INPUT OPERATIONAL AMPLIFIERS

#### SEMICONDUCTOR TECHNICAL DATA

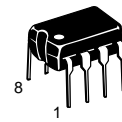

**P1 SUFFIX**  
PLASTIC PACKAGE  
CASE 626



**D SUFFIX**  
PLASTIC PACKAGE  
CASE 751  
(SO-8)

#### MAXIMUM RATINGS

Rating	Symbol	Value	Unit
Power Supply Voltages Single Supply Split Supplies	$V_{CC}$ $V_{CC}, V_{EE}$	36 $\pm 18$	Vdc
Input Differential Voltage Range (1)	$V_{IDR}$	$\pm 30$	Vdc
Input Common Mode Voltage Range (2)	$V_{ICR}$	$\pm 15$	Vdc
Junction Temperature	$T_J$	150	$^{\circ}\text{C}$
Storage Temperature Range	$T_{stg}$	-55 to +125	$^{\circ}\text{C}$
Operating Ambient Temperature Range MC3458 MC3358	$T_A$	0 to +70 -40 to +85	$^{\circ}\text{C}$

- NOTES:** 1. Split Power Supplies.  
2. For supply voltages less than  $\pm 18$  V, the absolute maximum input voltage is equal to the supply voltage.

#### PIN CONNECTIONS

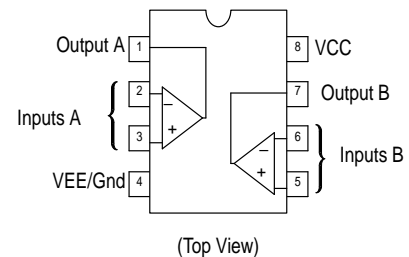

#### ORDERING INFORMATION

Device	Operating Temperature Range	Package
MC3358P1	$T_A = -40^{\circ}$ to $+85^{\circ}\text{C}$	Plastic DIP
MC3458D	$T_A = 0^{\circ}$ to $+70^{\circ}\text{C}$	SO-8
MC3458P1		Plastic DIP

# MC3458 MC3358

**ELECTRICAL CHARACTERISTICS** (For MC3458,  $V_{CC} = +15\text{ V}$ ,  $V_{EE} = -15\text{ V}$ ,  $T_A = 25^\circ\text{C}$ , unless otherwise noted.)  
 (For MC3358,  $V_{CC} = +14\text{ V}$ ,  $V_{EE} = \text{Gnd}$ ,  $T_A = 25^\circ\text{C}$ , unless otherwise noted.)

Characteristic	Symbol	MC3458			MC3358			Unit
		Min	Typ	Max	Min	Typ	Max	
Input Offset Voltage $T_A = T_{\text{high}} \text{ to } T_{\text{low}}$ (Note 1)	$V_{IO}$	–	2.0	10	–	2.0	8.0	mV
		–	–	12	–	–	10	
Input Offset Current $T_A = T_{\text{high}} \text{ to } T_{\text{low}}$	$I_{IO}$	–	30	50	–	30	75	nA
		–	–	200	–	–	250	
Large Signal Open Loop Voltage Gain $V_O = \pm 10\text{ V}$ , $R_L = 2.0\text{ k}\Omega$ , $T_A = T_{\text{high}} \text{ to } T_{\text{low}}$	$A_{VOL}$	20	200	–	20	200	–	V/mV
		15	–	–	15	–	–	
Input Bias Current $T_A = T_{\text{high}} \text{ to } T_{\text{low}}$	$I_{IB}$	–	–200	–500	–	–200	–500	nA
		–	–	–800	–	–	–1000	
Output Impedance, $f = 20\text{ Hz}$	$z_O$	–	75	–	–	75	–	$\Omega$
Input Impedance, $f = 20\text{ Hz}$	$z_I$	0.3	1.0	–	0.3	1.0	–	M $\Omega$
Output Voltage Range $R_L = 10\text{ k}\Omega$ $R_L = 2.0\text{ k}\Omega$ $R_L = 2.0\text{ k}\Omega$ , $T_A = T_{\text{high}} \text{ to } T_{\text{low}}$	$V_{OR}$	$\pm 12$	$\pm 13.5$	–	12	12.5	–	V
		$\pm 10$	$\pm 13$	–	10	12	–	
		$\pm 10$	–	–	10	–	–	
Input Common Mode Voltage Range	$V_{ICR}$	+13 – $V_{EE}$	+13.5 – $V_{EE}$	–	+13 – $V_{EE}$	+13.5 – $V_{EE}$	–	V
Common Mode Rejection Ratio, $R_S \leq 10\text{ k}\Omega$	CMR	70	90	–	70	90	–	dB
Power Supply Current ( $V_O = 0$ ) $R_L = \infty$	$I_{CC}$ , $I_{EE}$	–	1.6	3.7	–	1.6	3.7	mA
Individual Output Short Circuit Current (Note 2)	$I_{SC}$	$\pm 10$	$\pm 20$	$\pm 45$	$\pm 10$	$\pm 30$	$\pm 45$	mA
Positive Power Supply Rejection Ratio	PSRR+	–	30	150	–	30	150	$\mu\text{V/V}$
Negative Power Supply Rejection Ratio	PSRR–	–	30	150	–	–	–	$\mu\text{V/V}$
Average Temperature Coefficient of Input Offset Current, $T_A = T_{\text{high}} \text{ to } T_{\text{low}}$	$\Delta I_{IO}/\Delta T$	–	50	–	–	50	–	$\text{pA}/^\circ\text{C}$
Average Temperature Coefficient of Input Offset Current, $T_A = T_{\text{high}} \text{ to } T_{\text{low}}$	$\Delta V_{IO}/\Delta T$	–	10	–	–	10	–	$\mu\text{V}/^\circ\text{C}$
Power Bandwidth $A_V = 1$ , $R_L = 2.0\text{ k}\Omega$ , $V_O = 20\text{ V}_{pp}$ , THD = 5%	BWp	–	9.0	–	–	9.0	–	kHz
Small Signal Bandwidth $A_V = 1$ , $R_L = 10\text{ k}\Omega$ , $V_O = 50\text{ mV}$	BW	–	1.0	–	–	1.0	–	MHz
Slew Rate $A_V = 1$ , $V_I = -10\text{ V to } +10\text{ V}$	SR	–	0.6	–	–	0.6	–	$\text{V}/\mu\text{s}$
Rise Time $A_V = 1$ , $R_L = 10\text{ k}\Omega$ , $V_O = 50\text{ mV}$	$t_{TLH}$	–	0.35	–	–	0.35	–	$\mu\text{s}$
Fall Time $A_V = 1$ , $R_L = 10\text{ k}\Omega$ , $V_O = 50\text{ mV}$	$t_{THL}$	–	0.35	–	–	0.35	–	$\mu\text{s}$
Overshoot $A_V = 1$ , $R_L = 10\text{ k}\Omega$ , $V_O = 50\text{ mV}$	os	–	20	–	–	20	–	%
Phase Margin $A_V = 1$ , $R_L = 2.0\text{ k}\Omega$ , $C_L = 200\text{ pF}$	$\phi_m$	–	60	–	–	60	–	Degrees
Crossover Distortion ( $V_{in} = 30\text{ mV}_{pp}$ , $V_{out} = 2.0\text{ V}_{pp}$ , $f = 10\text{ kHz}$ )	–	–	1.0	–	–	1.0	–	%

**NOTES:** 1.  $T_{\text{high}} = 70^\circ\text{C}$  for MC3458,  $85^\circ\text{C}$  for MC3358  
 $T_{\text{low}} = 0^\circ\text{C}$  for MC3458,  $-40^\circ\text{C}$  for MC3358  
 2. Not to exceed maximum package power dissipation.

## MC3458 MC3358

### ELECTRICAL CHARACTERISTICS (V<sub>CC</sub> = 5.0 V, V<sub>EE</sub> = Gnd, T<sub>A</sub> = 25°C, unless otherwise noted.)

Characteristic	Symbol	MC3458			MC3358			Unit
		Min	Typ	Max	Min	Typ	Max	
Input Offset Voltage	V <sub>IO</sub>	–	2.0	5.0	–	2.0	10	mV
Input Offset Current	I <sub>IO</sub>	–	30	50	–	–	75	nA
Input Bias Current	I <sub>IB</sub>	–	–200	–500	–	–	–500	nA
Large Signal Open Loop Voltage Gain R <sub>L</sub> = 2.0 kΩ	A <sub>VOL</sub>	20	200	–	20	200	–	V/mV
Power Supply Rejection Ratio	PSRR	–	–	150	–	–	150	μV/V
Output Voltage Range (Note 3) R <sub>L</sub> = 10 kΩ, V <sub>CC</sub> = 5.0 V R <sub>L</sub> = 10 kΩ, 5.0 V ≤ V <sub>CC</sub> ≤ 30 V	V <sub>OR</sub>	3.3 –	3.5 V <sub>CC</sub> –1.7	– –	3.3 –	3.5 V <sub>CC</sub> –1.7	– –	V <sub>pp</sub>
Power Supply Current	I <sub>CC</sub>	–	2.5	7.0	–	2.5	4.0	mA
Channel Separation f = 1.0 kHz to 20 kHz (Input Referenced)	CS	–	–120	–	–	–120	–	dB

**NOTE:** 3. Output will swing to ground with a 10 kΩ pull down resistor.

# MC3458 MC3358

## Representative Schematic Diagram (1/2 of Circuit Shown)

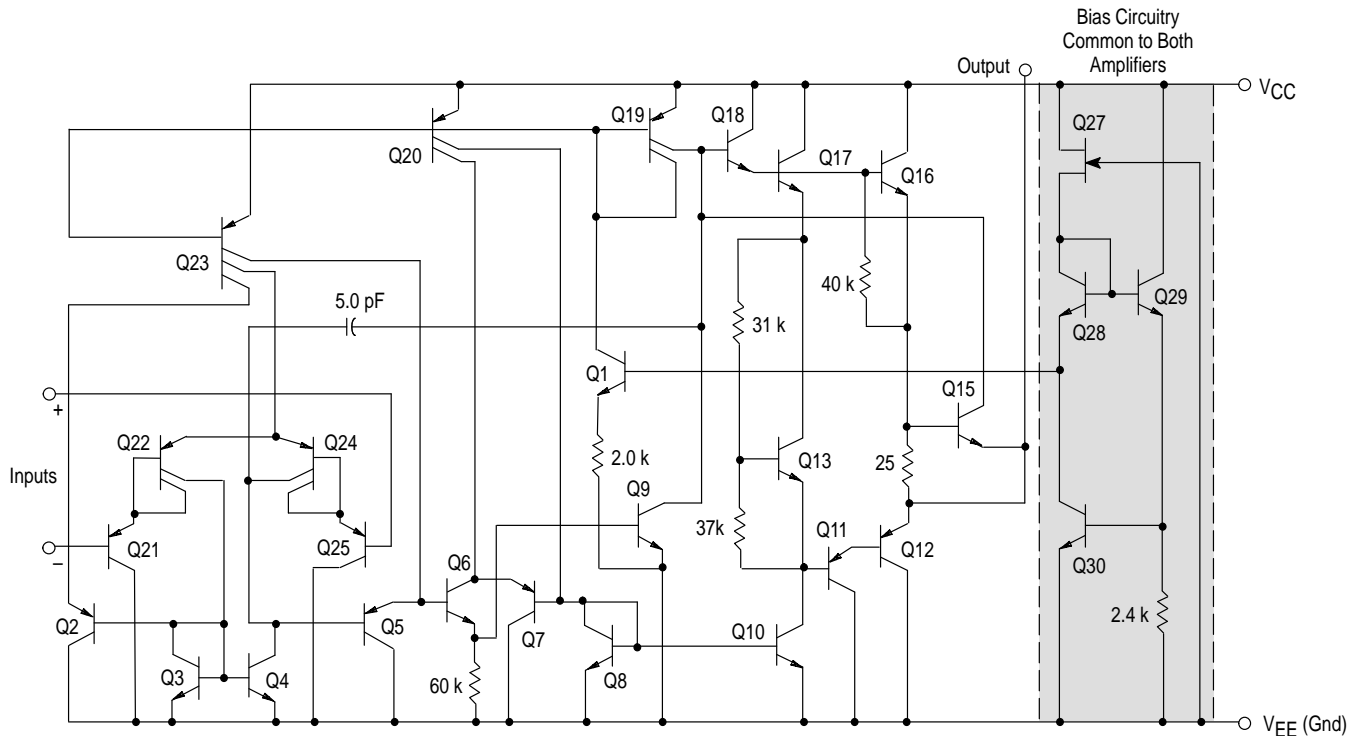

### Inverter Pulse Response

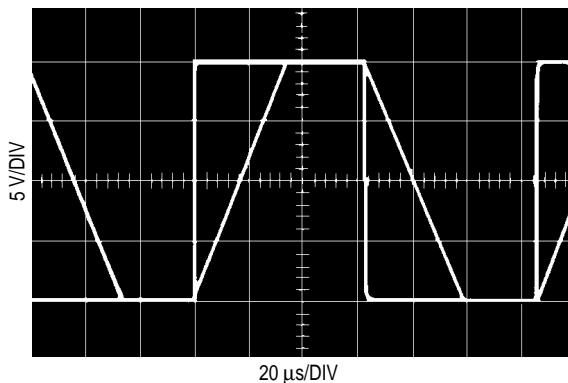

### CIRCUIT DESCRIPTION

The MC3458/3358 is made using two internally compensated, two-stage operational amplifiers. The first stage of each consists of differential input devices Q24 and Q22 with input buffer transistors Q25 and Q21 and the

differential to single ended converter Q3 and Q4. The first stage performs not only the first stage gain function but also performs the level shifting and transconductance reduction functions. By reducing the transconductance, a smaller compensation capacitor (only 5.0 pF) can be employed, thus saving chip area. The transconductance reduction is accomplished by splitting the collectors of Q24 and Q22. Another feature of this input stage is that the input Common Mode range can include the negative supply or ground, in single supply operation, without saturating either the input devices or the differential to single-ended converter. The second stage consists of a standard current source load amplifier stage.

The output stage is unique because it allows the output to swing to ground in single supply operation and yet does not exhibit any crossover distortion in split supply operation. This is possible because Class AB operation is utilized.

Each amplifier is biased from an internal voltage regulator which has a low temperature coefficient thus giving each amplifier good temperature characteristics as well as excellent power supply rejection.

Figure 1. Sine Wave Response

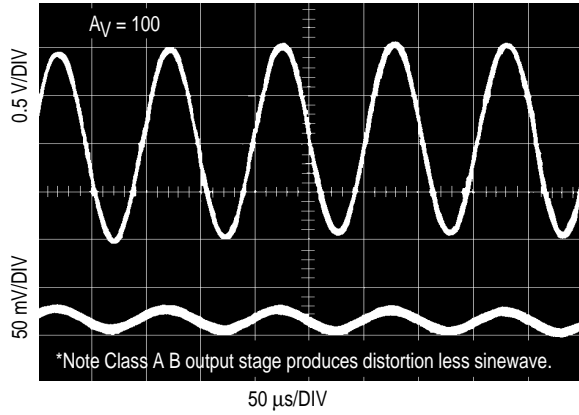

Figure 2. Open Loop Frequency Response

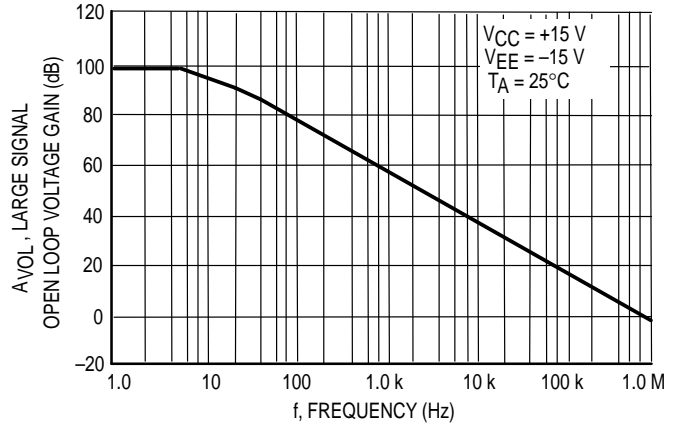

Figure 3. Power Bandwidth

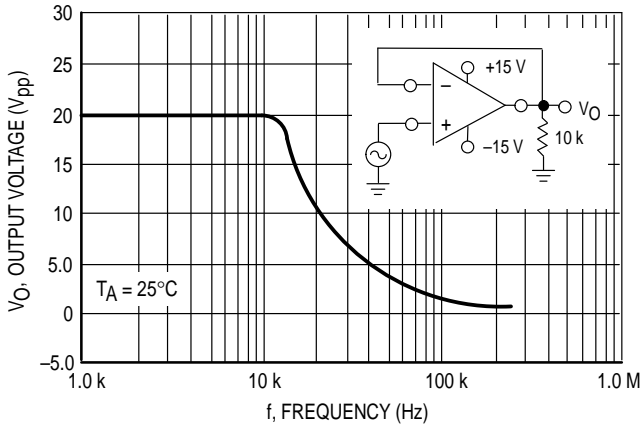

Figure 4. Output Swing versus Supply Voltage

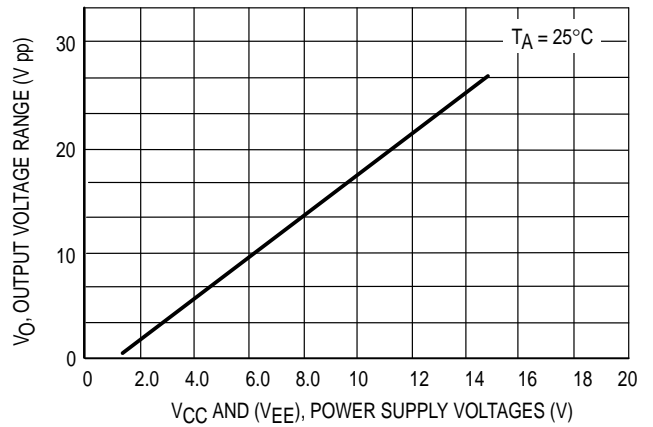

Figure 5. Input Bias Current versus Temperature

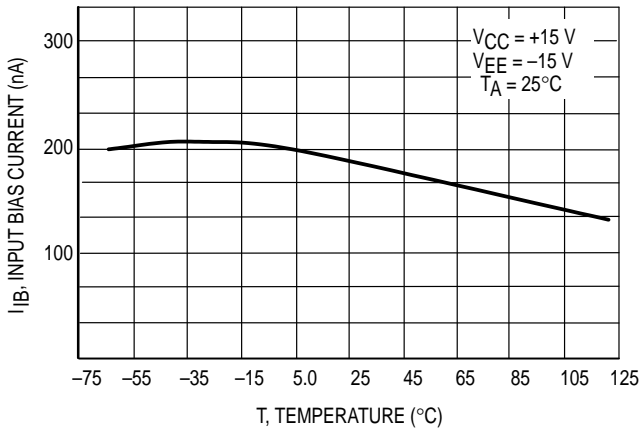

Figure 6. Input Bias Current versus Supply Voltage

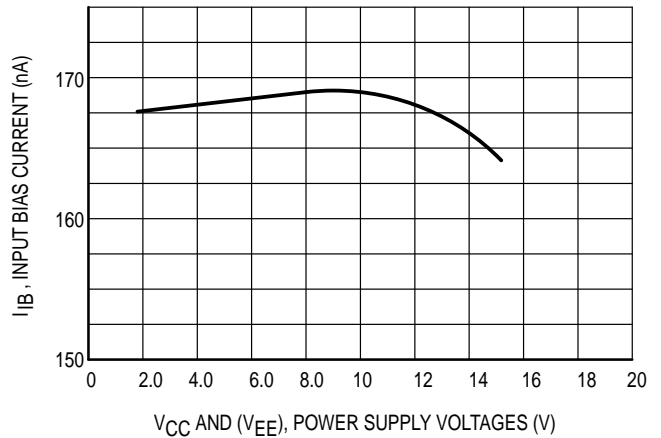

Figure 7. Voltage Reference

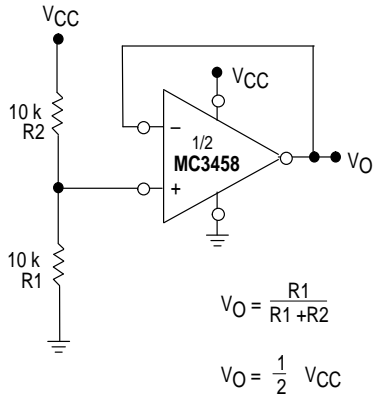

Figure 8. Wien Bridge Oscillator

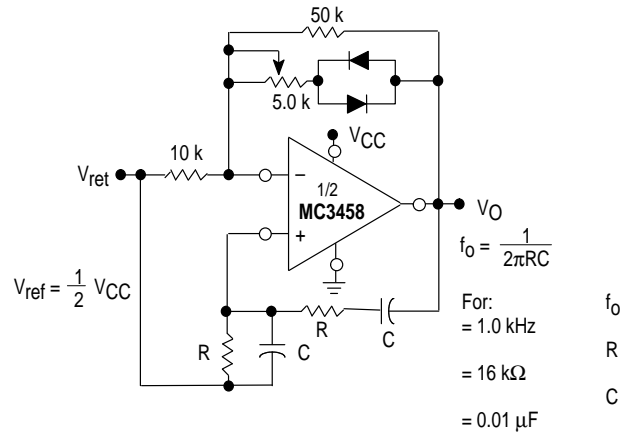

Figure 9. High Impedance Differential Amplifier

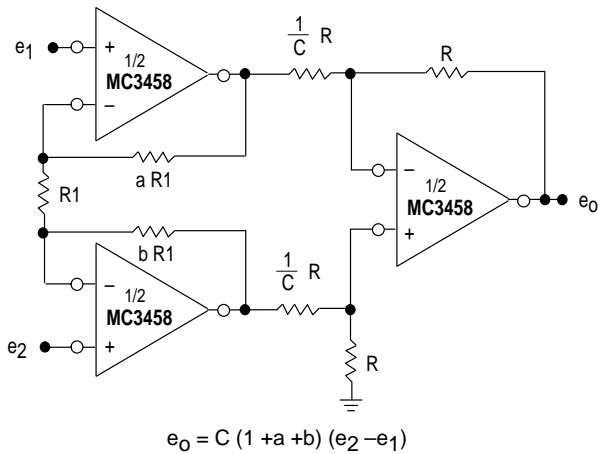

Figure 10. Comparator with Hysteresis

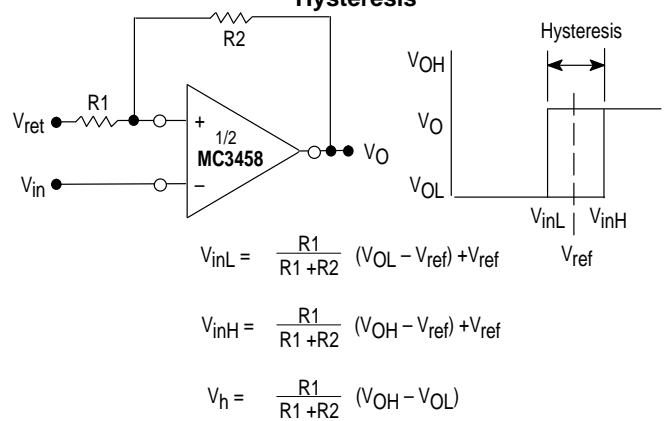
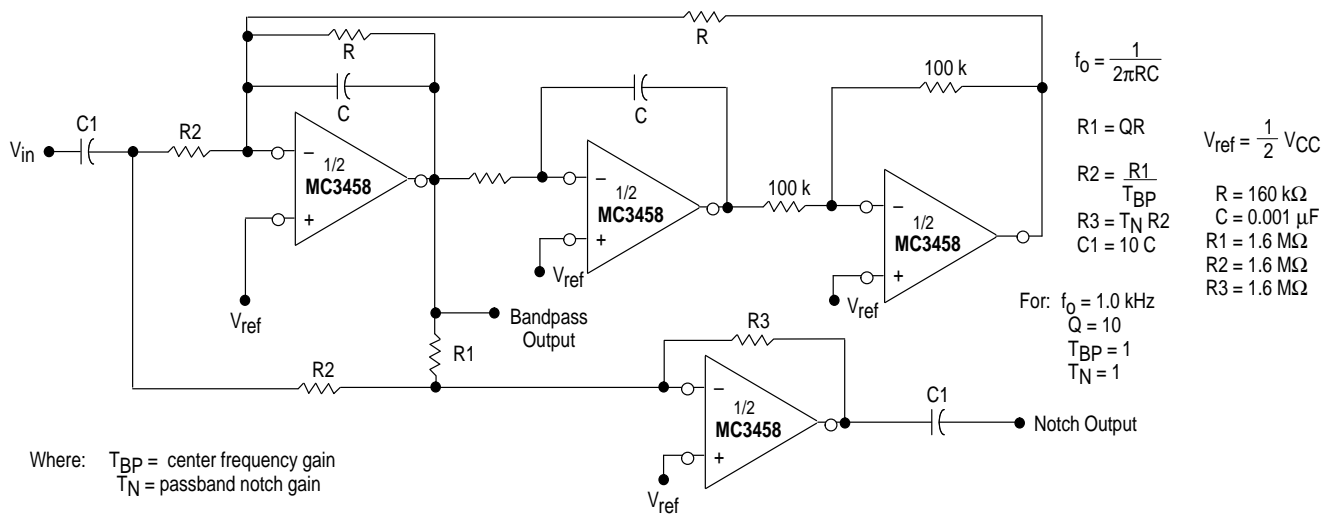

Figure 11. Bi-Quad Filter



# MC3458 MC3358

Figure 12. Function Generator

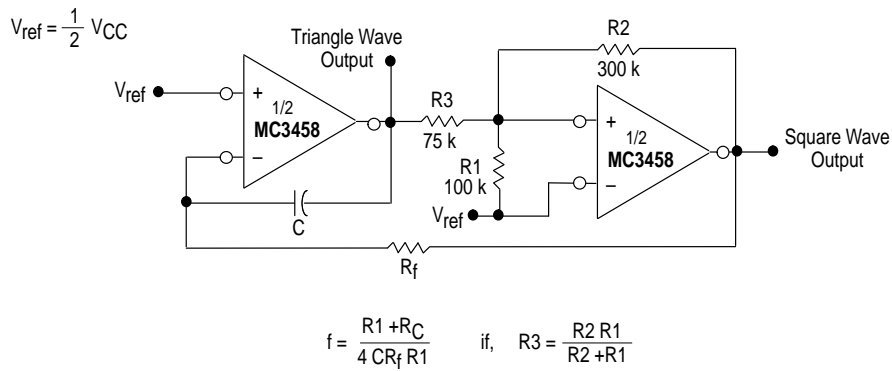
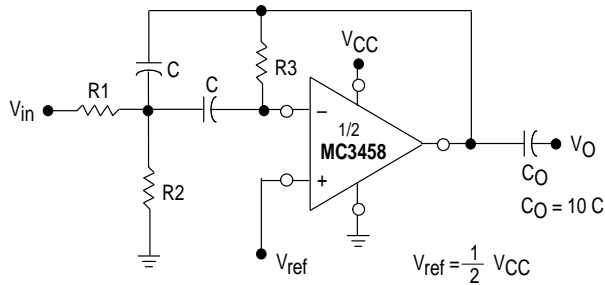

Figure 13. Multiple Feedback Bandpass Filter



Given:  $f_0$  = center frequency  
 $A(f_0)$  = gain at center frequency

Choose value  $f_0$ , C.

Then:  $R3 = \frac{Q}{\pi f_0 C}$      $R1 = \frac{R3}{2 A(f_0)}$      $R2 = \frac{R1 R5}{4Q^2 R1 - R3}$

For less than 10% error from operational amplifier  $\frac{Q_0 f_0}{BW} < 0.1$

where,  $f_0$  and BW are expressed in Hz.

If source impedance varies, filter may be preceded with voltage follower buffer to stabilize filter parameters.

Motorola reserves the right to make changes without further notice to any products herein. Motorola makes no warranty, representation or guarantee regarding the suitability of its products for any particular purpose, nor does Motorola assume any liability arising out of the application or use of any product or circuit, and specifically disclaims any and all liability, including without limitation consequential or incidental damages. "Typical" parameters which may be provided in Motorola data sheets and/or specifications can and do vary in different applications and actual performance may vary over time. All operating parameters, including "Typicals" must be validated for each customer application by customer's technical experts. Motorola does not convey any license under its patent rights nor the rights of others. Motorola products are not designed, intended, or authorized for use as components in systems intended for surgical implant into the body, or other applications intended to support or sustain life, or for any other application in which the failure of the Motorola product could create a situation where personal injury or death may occur. Should Buyer purchase or use Motorola products for any such unintended or unauthorized application, Buyer shall indemnify and hold Motorola and its officers, employees, subsidiaries, affiliates, and distributors harmless against all claims, costs, damages, and expenses, and reasonable attorney fees arising out of, directly or indirectly, any claim of personal injury or death associated with such unintended or unauthorized use, even if such claim alleges that Motorola was negligent regarding the design or manufacture of the part. Motorola and  are registered trademarks of Motorola, Inc. Motorola, Inc. is an Equal Opportunity/Affirmative Action Employer.

# MC3458 MC3358

## OUTLINE DIMENSIONS

### P1 SUFFIX PLASTIC PACKAGE CASE 626-05 ISSUE K

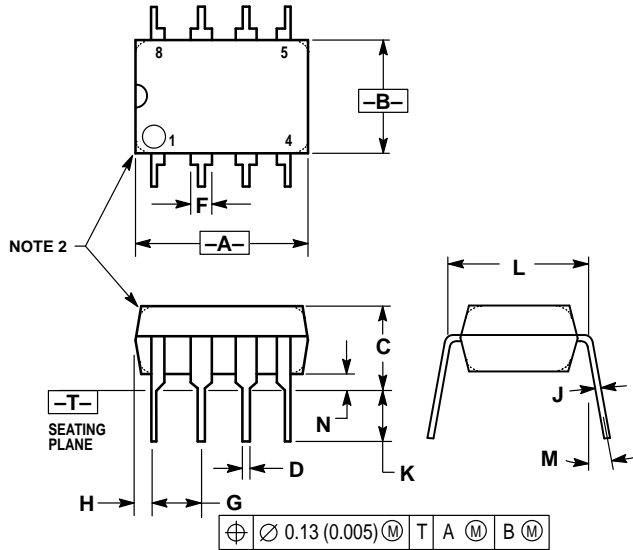

NOTES:

1. DIMENSION L TO CENTER OF LEAD WHEN FORMED PARALLEL.
2. PACKAGE CONTOUR OPTIONAL (ROUND OR SQUARE CORNERS).
3. DIMENSIONING AND TOLERANCING PER ANSI Y14.5M, 1982.

DIM	MILLIMETERS		INCHES	
	MIN	MAX	MIN	MAX
A	9.40	10.16	0.370	0.400
B	6.10	6.60	0.240	0.260
C	3.94	4.45	0.155	0.175
D	0.38	0.51	0.015	0.020
F	1.02	1.78	0.040	0.070
G	2.54 BSC		0.100 BSC	
H	0.76	1.27	0.030	0.050
J	0.20	0.30	0.008	0.012
K	2.92	3.43	0.115	0.135
L	7.62 BSC		0.300 BSC	
M	—		10°	
N	0.76	1.01	0.030	0.040

### D SUFFIX PLASTIC PACKAGE CASE 751-05 (SO-8) ISSUE R

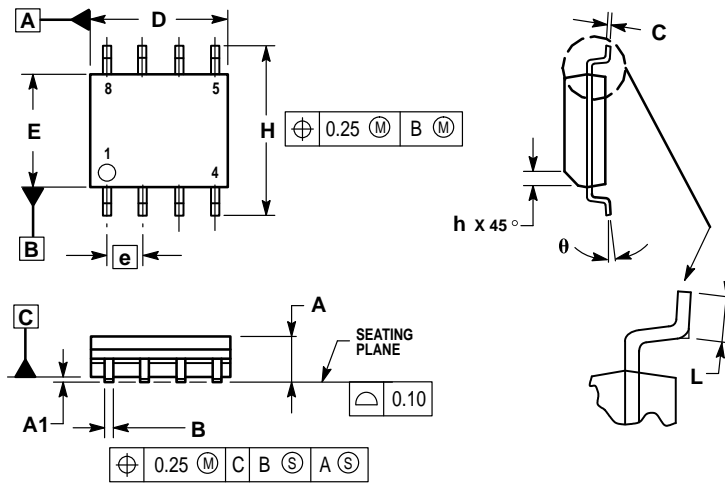

NOTES:

1. DIMENSIONING AND TOLERANCING PER ASME Y14.5M, 1994.
2. DIMENSIONS ARE IN MILLIMETERS.
3. DIMENSION D AND E DO NOT INCLUDE MOLD PROTRUSION.
4. MAXIMUM MOLD PROTRUSION 0.15 PER SIDE.
5. DIMENSION B DOES NOT INCLUDE MOLD PROTRUSION. ALLOWABLE DAMBAR PROTRUSION SHALL BE 0.127 TOTAL IN EXCESS OF THE B DIMENSION AT MAXIMUM MATERIAL CONDITION.

DIM	MILLIMETERS	
	MIN	MAX
A	1.35	1.75
A1	0.10	0.25
B	0.35	0.49
C	0.18	0.25
D	4.80	5.00
E	3.80	4.00
e	1.27 BSC	
H	5.80	6.20
h	0.25	0.50
L	0.40	1.25
θ	0° 7°	

**How to reach us:**

**USA/EUROPE/Locations Not Listed:** Motorola Literature Distribution;  
P.O. Box 20912; Phoenix, Arizona 85036. 1-800-441-2447 or 602-303-5454

**MFAX:** RMFAX0@email.sps.mot.com - TOUCHTONE 602-244-6609  
**INTERNET:** <http://Design-NET.com>

**JAPAN:** Nippon Motorola Ltd.; Tatsumi-SPD-JLDC, 6F Seibu-Butsuryu-Center,  
3-14-2 Tatsumi Koto-Ku, Tokyo 135, Japan. 03-81-3521-8315

**ASIA/PACIFIC:** Motorola Semiconductors H.K. Ltd.; 8B Tai Ping Industrial Park,  
51 Ting Kok Road, Tai Po, N.T., Hong Kong. 852-26629298



MC3458/D

