

NEC[®]**500 MHz DUAL-MODULUS
PRESCALER****UPB571C****DESCRIPTION**

The UPB571C is a 500 MHz Low Power Dual - modulus prescaler intended for use in PLL digital tuning systems in connection with NEC PLL LSI ICs.

The device provides 1/64, 1/65, 1/32, 1/33, 1/16 and 1/17 division ratio for pulse swallowing method and is guaranteed to operate up to 500 MHz over a -35°C to +75°C temperature range.

FEATURES

- High frequency operation: 500 MHz MAX. ($V_{IN} = 400 \text{ mV}_{p-p}$)
- Dual mode operation with pulse swallowing method
 $\div 64/\div 65$, $\div 32/\div 33$, $\div 16/\div 17$
- Single supply Voltage: $V_{CC} = 5.0 \text{ V} \pm 10\%$
- Low supply current: $I_{CC} = 11 \text{ mA (TYP.)}$
- Small package: 8 pin plastic dual in-line package (DIP)

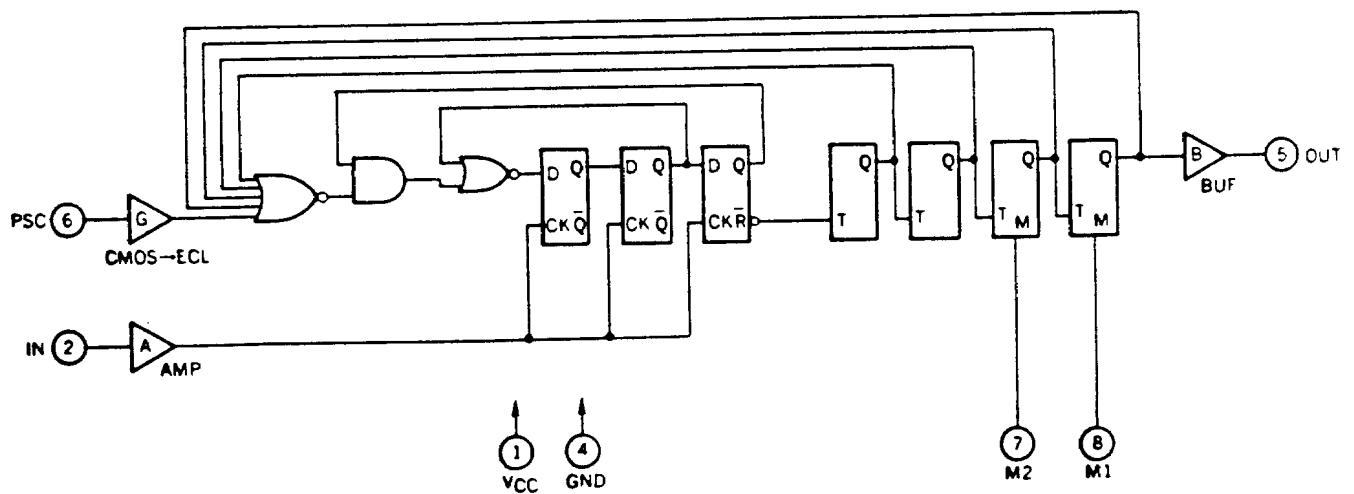
BLOCK DIAGRAM

CONNECTION DIAGRAM

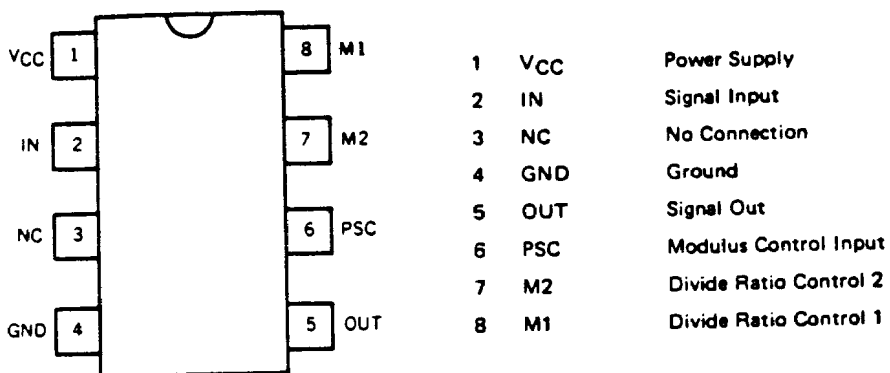

DIVIDE RATIO

| M1 | M2 | PSC | DIVIDE RATIO |
|----|----|-----|--------------|
| L | L | H | 64 |
| L | L | L | 65 |
| L | H | H | 32 |
| L | H | L | 33 |
| H | H | H | 16 |
| H | H | L | 17 |

M Terminal

"H" : Connect to VCC

"L" : Open

PSC Terminal

"H" : 0.8 VCC to VCC [V]

"L" : 0 to 0.2 VCC [V]

ABSOLUTE MAXIMUM RATINGS

| | | | |
|-----------------------|------------------|------------------------------|----|
| Supply Voltage | VCC | -0.5 to +6.0 | V |
| Input Voltage | V _I | -0.5 to V _{CC} +0.5 | V |
| Output Current | I _o | -10 | mA |
| Storage Temperature | T _{stg} | -55 to +125 | °C |
| Operating Temperature | T _{opt} | -35 to +75 | °C |

RECOMMENDED OPERATING CONDITIONS

| CHARACTERISTIC | SYMBOL | MIN. | TYP. | MAX. | UNIT | TEST CONDITIONS |
|--------------------------|------------------|---------------------|------|---------------------|------------------|---|
| Supply Voltage | V _{CC} | 4.5 | 5.0 | 5.5 | V | |
| Input Amplitude | V _{in} | 0.4 | | 1.2 | V _{p-p} | IN Terminal |
| High Level Input Voltage | V _{IH} | 0.8 V _{CC} | | | V | PSC Terminal |
| Low Level Input Voltage | V _{IL} | | | 0.2 V _{CC} | V | PSC Terminal |
| Frequency Response | f _{in} | 100 | | 500 | MHz | IN Terminal, V _{in} = 0.4 V _{p-p} |
| Output Load Capacitance | CL | | | 10 | pF | |
| Operating Temperature | T _{opt} | -35 | | 75 | °C | |

ELECTRICAL CHARACTERISTICS (V_{CC} = 5±0.5 [V], T_a = -35 to +75 °C)

| CHARACTERISTIC | SYMBOL | MIN. | TYP. | MAX. | UNIT | TEST CONDITIONS |
|--------------------------|-----------------|------|------|------|------------------|---|
| Supply Current | i _{CC} | | 11 | 15.7 | mA | |
| Output Amplitude | V _O | 0.9 | 1.2 | | V _{p-p} | Out Terminal |
| High Level Input Current | I _{IH} | | | 5 | μA | PSC, M, Terminal |
| Set-up Time | t _s | | | 30 | ns | PSC to Out |
| Output Rise Time | t _r | 5 | | 15 | ns | C _L = 10 pF, 20 to 80 % Out Terminal |

MEASUREMENT CIRCUIT

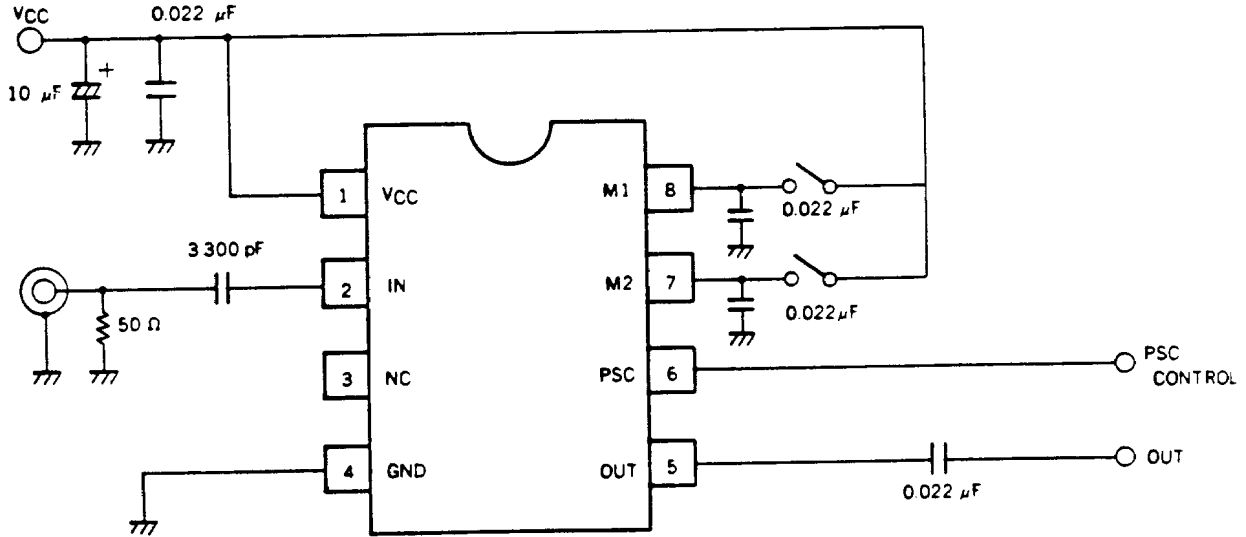

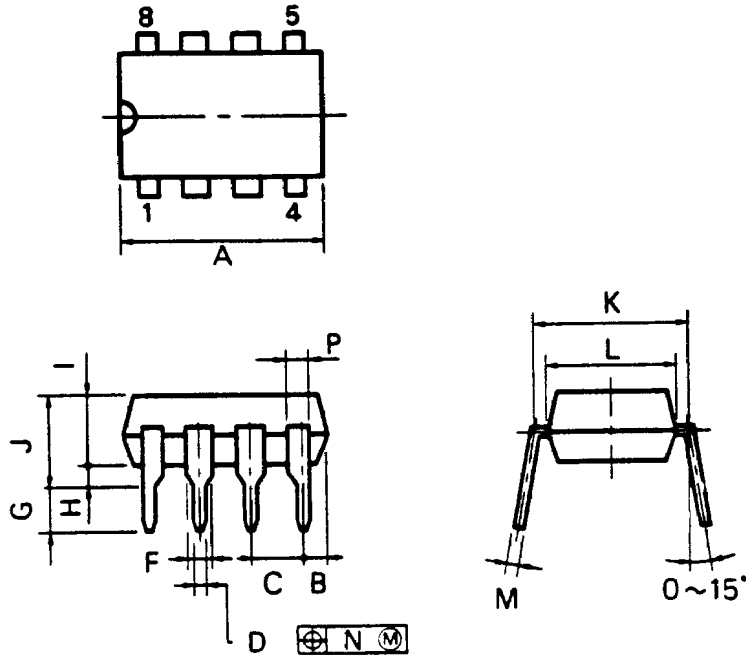

P8C-100-300B.C

NOTES

- 1) Each lead centerline is located within 0.25 mm (0.01 inch) of its true position (T.P.) at maximum material condition.
- 2) Item "K" to center of leads when formed parallel.

| ITEM | MILLIMETERS | INCHES |
|------|-----------------------|-------------------------|
| A | 10.16 MAX. | 0.400 MAX. |
| B | 1.27 MAX. | 0.050 MAX. |
| C | 2.54 (T.P.) | 0.100 (T.P.) |
| D | 0.50 ^{+0.10} | 0.020 ^{+0.004} |
| F | 1.4 MIN. | 0.055 MIN. |
| G | 3.2 ^{+0.3} | 0.126 ^{+0.012} |
| H | 0.51 MIN. | 0.020 MIN. |
| I | 4.31 MAX. | 0.170 MAX. |
| J | 5.08 MAX. | 0.200 MAX. |
| K | 7.62 (T.P.) | 0.300 (T.P.) |
| L | 6.4 | 0.252 |
| M | 0.25 ^{+0.08} | 0.010 ^{+0.003} |
| N | 0.25 | 0.01 |
| P | 0.9 MIN. | 0.035 MIN. |

EXCLUSIVE AGENT FOR NEC Corporation RF & MICROWAVE SEMICONDUCTOR PRODUCTS - U.S. & CANADA

CALIFORNIA EASTERN LABORATORIES, INC. • Headquarters • 3280 Jay Street • Santa Clara, CA 95054 • (408) 988-3500 • Telex 34-8383/FAX (408) 988-0279

DATA SUBJECT TO CHANGE WITHOUT NOTICE

024272

PRINTED IN U.S.A. - 3/89