

**RGB ENCODER**

The KA2195D is a monolithic integrated circuit designed for RGB encoder of video system. This device contains matrix of R-Y/B-Y, modulator, pulse generator, regulator and built in BPF of chroma and delay line of luminance. The KA2195D is suitable for video equipment

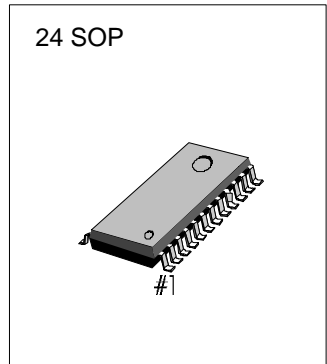

**FUNCTION**

- Regulator
- Mixer of R-Y, B-Y
- Modulator
- Pulse generator
- Audio buffer
- X-tal oscillator
- Clamp circuit
- BPF & D.L circuit

**ORDERING INFORMATION**

Device	Package	Operating Temperature
KA2195D	24SOP	-20~+70°C

**FEATURE**

- Lower operating voltage: Vcc= 5V
- Stabilized bias condition in regulator
- Available only NTSC system
- Included 75 ohm driver (RGB Output, composite video output, composite sync. output)
- Sub-carrier frequency using X-tal and available external input
- Include BPF & delay line
  - :Minimized external components
- Audio buffer circuit
- R-Y, B-Y modulator

**BLOCK DIAGRAM**

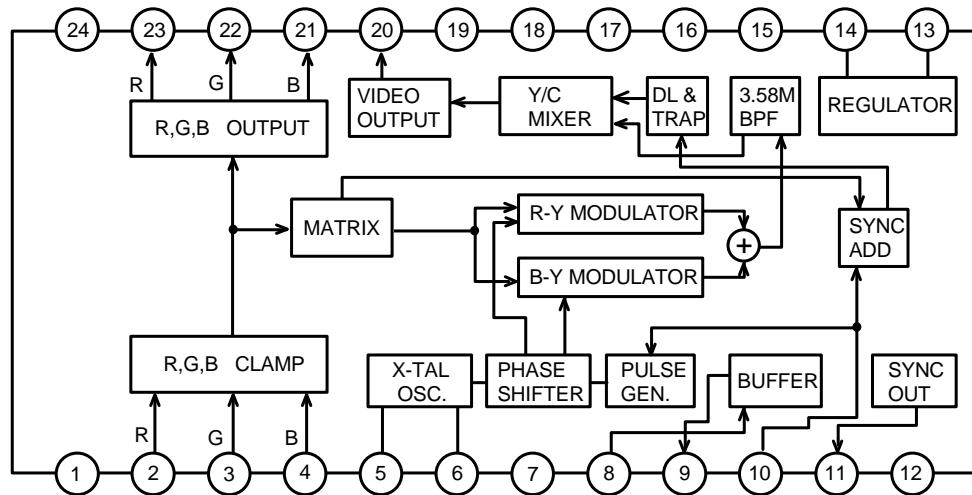

**PIN CONFIGURATION**



ELECTRONICS

# KA2195D

# RGB ENCODER FOR NTSC

Pin No.	DESCRIPTION	Pin No	DESCRIPTION
1	GND 1	13	REGULATOR CURRENT SINK
2	RED INPUT	14	2V REGULATOR OUTPUT
3	GREEN INPUT	15	N.C
4	BLUE INPUT	16	N.C
5	X-TAL OUT	17	N.C
6	X-TAL IN	18	N.C
7	NTSC S/W(VCC)	19	VCC 2
8	AUDIO IN	20	COMPOSITE VIDEO OUTPUT
9	AUDIO OUT	21	BLUE OUTPUT
10	COMPOSITE SYNC INPUT	22	GREEN OUTPUT
11	COMPOSITE SYNC OUTPUT	23	RED OUTPUT
12	VCC 1	24	GND 2

\* VCC 1,GND 1: EXCEPT OUTPUT STAGE

\* VCC 2, GND 2: OUTPUT STAGE

### ABSOLUTE MAXIMUM RATINGS (T<sub>A</sub>=25°C)

Characteristic	Symbol	Value	Unit
Supply Voltage	V <sub>CC</sub>	10	V
Power dissipation	P <sub>D</sub>	1250	mW
Operating Temperature	T <sub>OPR</sub>	-20~+70	°C
Storage Temperature	T <sub>STG</sub>	-55~+150	°C

### ELECTRICAL CHARACTERISTICS(T<sub>A</sub>=25°C, V<sub>CC</sub>=5V)

Characteristic	Symbol	Test Condition	Min	Typ	Max	Unit
Supply Current 1	I <sub>CC1</sub>	No Signal input	20	27	32	mA
Supply Current 2	I <sub>CC2</sub>	No Signal input	5.6	7.6	11	mA
R Output Voltage	V <sub>O</sub>	R <sub>IN</sub> =1 V <sub>P-P</sub>	0.64	0.71	0.78	V <sub>P-P</sub>
G Output Voltage	V <sub>O</sub>	G <sub>IN</sub> =1 V <sub>P-P</sub>	0.64	0.71	0.78	V <sub>P-P</sub>
B Output Voltage	V <sub>O</sub>	B <sub>IN</sub> =1 V <sub>P-P</sub>	0.64	0.71	0.78	V <sub>P-P</sub>
R Frequency Response	f <sub>C</sub>	R, G, B f = 200 KHz -dB POINT	5	-	-	MHz
G Frequency Response	f <sub>C</sub>		5	-	-	MHz
B Frequency Response	f <sub>C</sub>		5	-	-	MHz
Sync. Level	V <sub>OS</sub>	Condition:R, G, B and C Sync. input Measure Composite Video Output	0.26	0.29	0.33	V
R 100% Y Level	V <sub>O</sub>		0.19	0.21	0.25	V
G 100% Y Level	V <sub>O</sub>		0.38	0.42	0.48	V
B 100% Y Level	V <sub>O</sub>		0.07	0.08	0.09	V



ELECTRONICS

Characteristic	Symbol	Test Conditions	Min	Typ	Max	Unit
While 100% Y level	$V_O$	Composite Video Output	0.64	0.71	0.82	V
Differential Gain	DG		-	-	3.0	%
Differential Phase	DP		-	-	3.0	deg
Burst Level	$V_{OB}$		0.22	0.29	0.34	$V_{P-P}$
R Chroma Ratio	R/BN		2.8	3.15	3.5	times
G Chroma Ratio	G/BN		2.65	2.95	3.25	times
B Chroma Ratio	B/BN		2.01	2.24	2.57	times
R Phase	SR		94	104	114	deg
G Phase	SG		231	241	251	deg
B Phase	SB		337	347	357	deg
Burst Width	$T_{WB}$		2.5	2.75	3.6	us
Burst Position	$T_{DB}$		0.45	0.5	0.75	us
Carrier Leakage	VI		-	-	30	$mV_{P-P}$
C Sync. Output Level	$V_{OS}$		0.2	0.29	0.4	$V_{P-P}$
Audio Buffer Gain	$G_A$	$1V_{P-P}, f=1KHz$	-1.0	0	1.0	dB
Audio Freq. Response	$F_A$	-3dB	30	-	-	KHz
Audio Distortion	THD	$1V_{P-P}, f=1KHz$	-	-	1.0	%



ELECTRONICS

\* AUDIO OUT

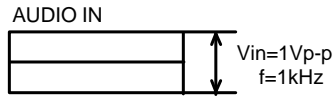

\* SYNC. OUT

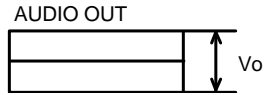
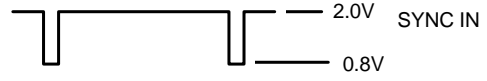

\* COMPOSITE VIDEO OUT

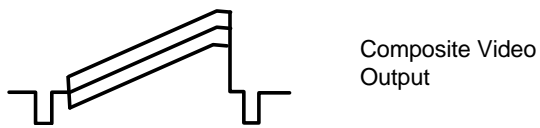
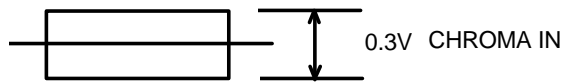
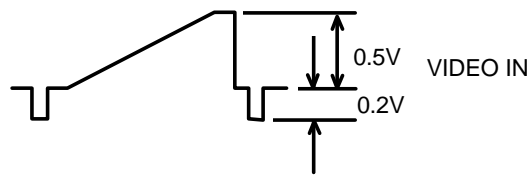
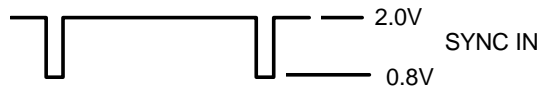

TEST WAVEFORM

\* R,G,B OUT

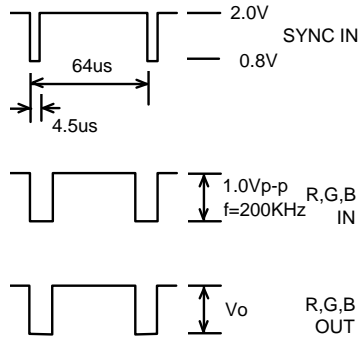

\* COMPOSITE VIDEO OUT

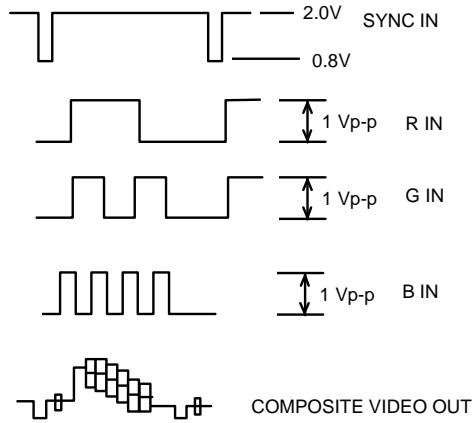

# KA2195D

# RGB ENCODER FOR NTSC

## TEST CIRCUIT

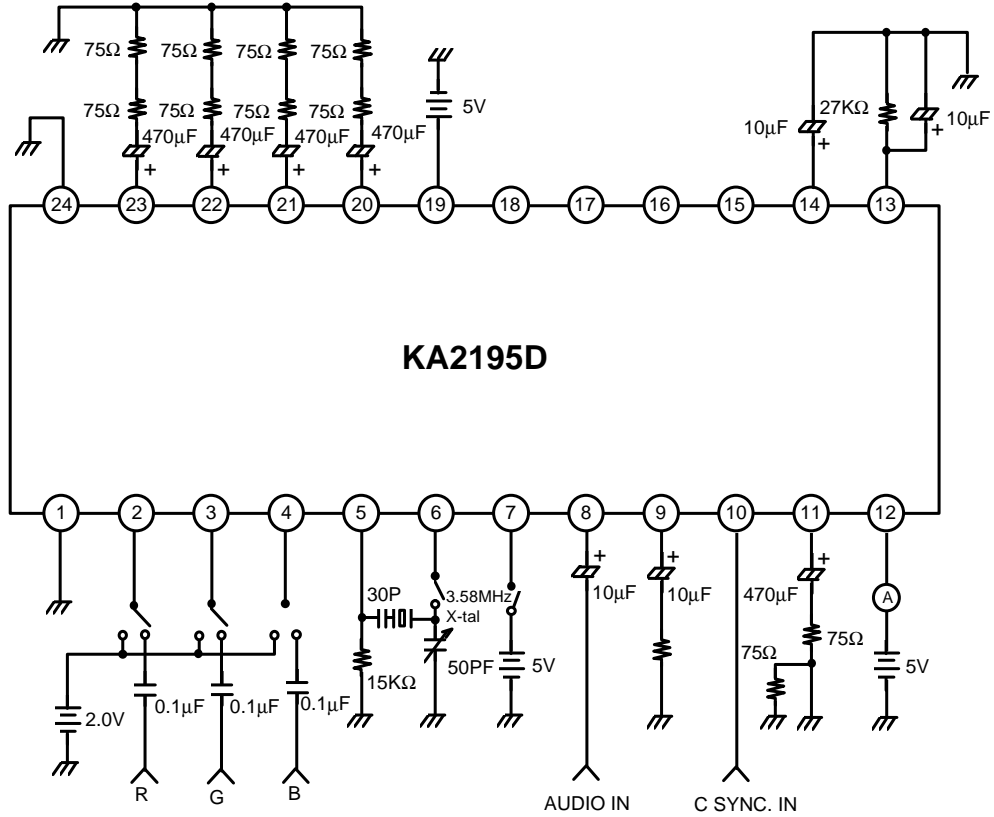

APPLICATION CIRCUIT

