

PRELIMINARY
 Notice: This is not a final specification.
 Some parametric limits are subject to change.

M61509FP

TONE CONTROL/VOLUME CONTROL

DESCRIPTION

The M61509FP is the sound controller powered by the "QXpander" system. The "QXpander" system produces normal and wide 3D sound expansion from any stereo input signal.

(Note) This device is produced under license from QSound Lab, Inc. (Canada).

FEATURES

- Built-in "QXpander" sound technology
- Electronic volume.
0 ~ -84dB, infinitesimal
- 2-band tone control
Bass(0 ~ +21dB/3dB STEP)
Treble(0 ~ +9dB/3dB STEP)
- 5 input selector(The fifth input can be used as REC OUT or MIC MIX.)

RECOMMENDED OPERATING CONDITIONS

Supply voltage range _____ + 2.25~+ 2.75V

SYSTEM BLOCK DIAGRAM

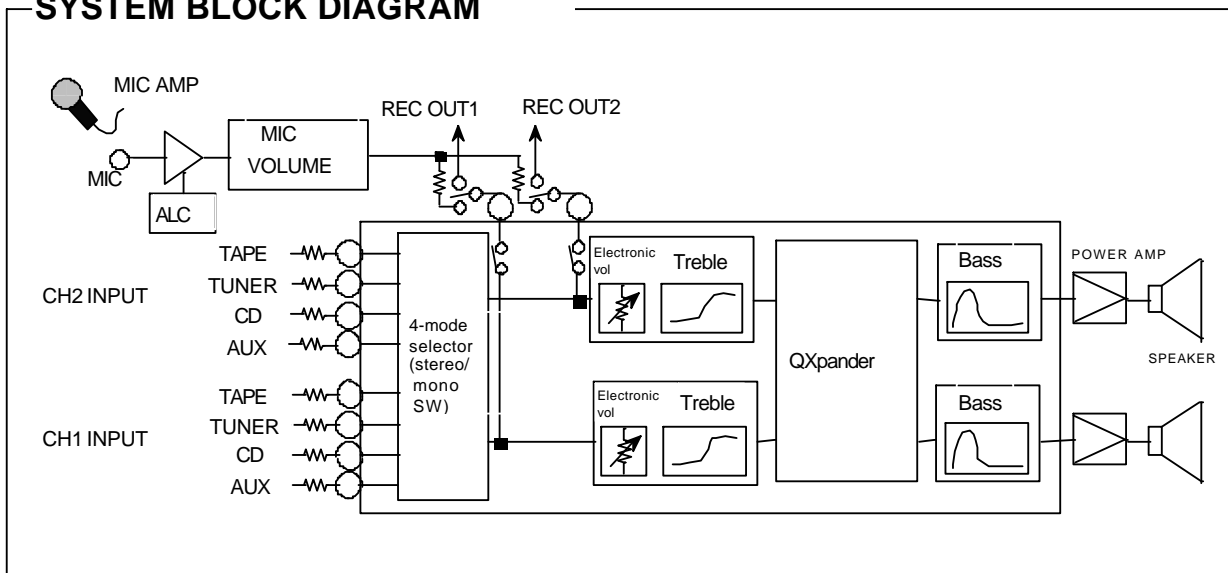

BLOCK DIAGRAM

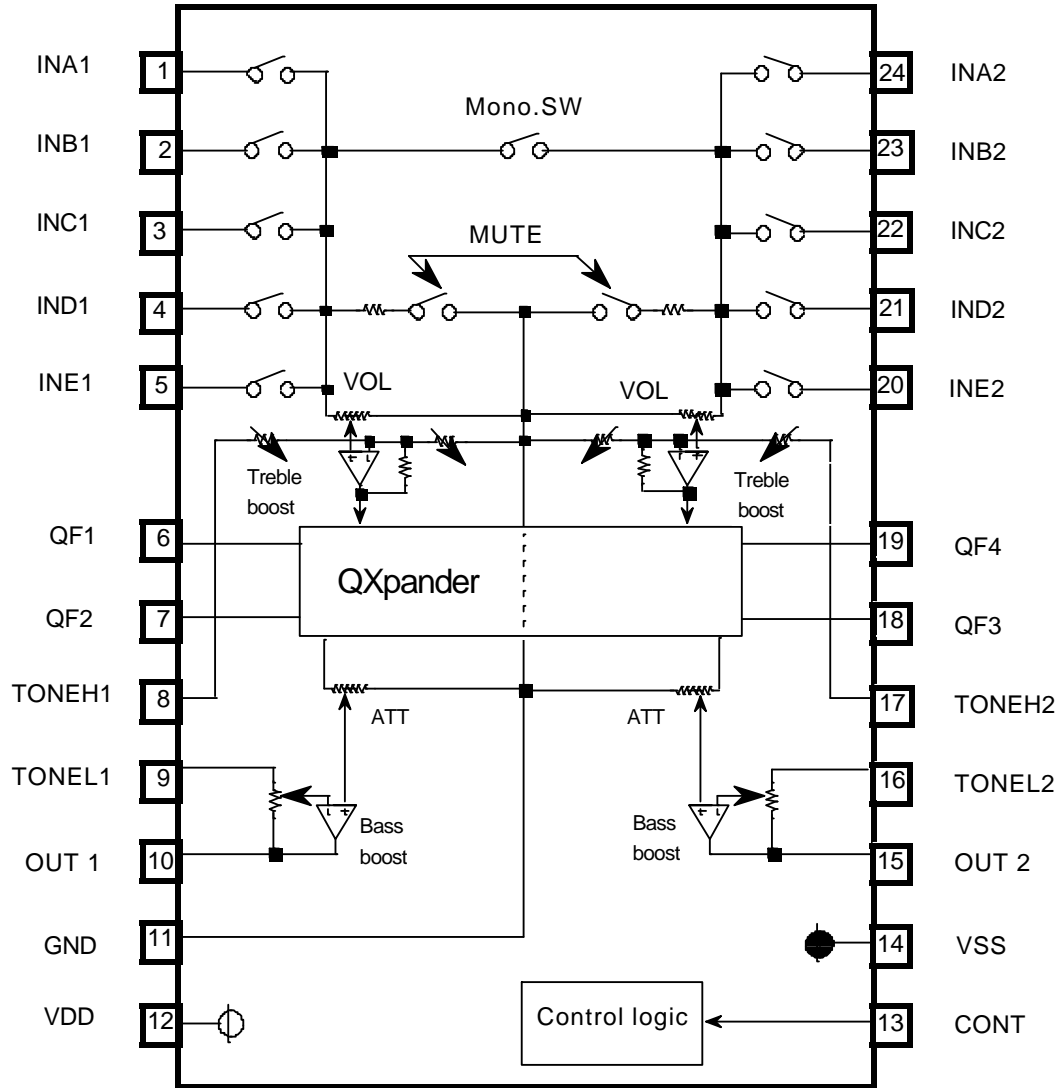

Units Resistance :ohm
Capacitance: F

PIN DESCRIPTION

Pin No.	Name	Function
1	IN A1	INPUTs of the channel 1 The switch of INE can be controlled independently. Please set "ALL OFF" mode when the switch of E is only ON.
2	IN B1	
3	IN C1	
4	IN D1	
5	INE1	
6	QF1	QXpander filter 1
7	QF2	QXpander filter 2
8	TONEH1	Treble control adjustment of the channel 1
9	TONEL1	Bass control adjustment of the channel 1
10	OUT1	OUTPUT of the channel 1
11	GND	Ground
12	VDD	Supply voltage(+)
13	CONT	Control data input from a microcontroller
14	VSS	Supply voltage(-)
15	OUT2	OUTPUT of the channel 2
16	TONEL2	Bass control adjustment of the channel 2
17	TONEH2	Treble control adjustment of the channel 2
18	QF3	QXpander filter 3
19	QF4	QXpander filter 4
20	INE2	INPUTs of the channel 2 The switch of INE can be controlled independently. Please set "ALL OFF" mode when the switch of E is only ON.
21	IN D2	
22	IN C2	
23	IN B2	
24	IN A2	

ABSOLUTE MAXIMUM RATINGS

(Ta=25 °C, unless otherwise noted)

Symbol	Parameter	Test conditions	Rating	Unit
VDD-VSS	Supply voltage		6.0	V
$K\theta$	Thermal derating	Note:1	5	mW/°C
Pd	Power dissipation		500	mW
Topr	Operating temperature		-20 ~ 75	°C
Tstg	Storage temperature		-40 ~ 125	°C

Thermal derating(maximum rating)

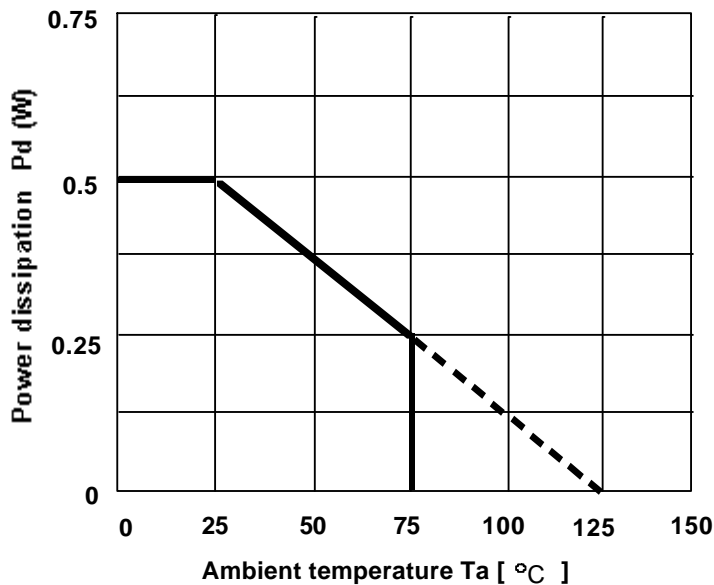

Note.1 reference PC Board

Size :70mmX70mm

Thickness:1.6mm

Material :glass epoxy

Copper pattern dimension

Width :0.25mm

Length :25 ~ 30mm/lead

Thickness:18um

Recommended operating conditions

Symbol	Parameter	Pin No.	Condition	Limits			Unit
				min.	typ.	max.	
VDD	Supply voltage(+)	12		2.25	2.5	2.75	V
VSS	Supply voltage(-)	14		-2.75	-2.5	-2.25	
CONT	Control data input voltage	13		GND	—	VDD	

CONTROL SIGNALS SPECIFICATION

(1) Wave form

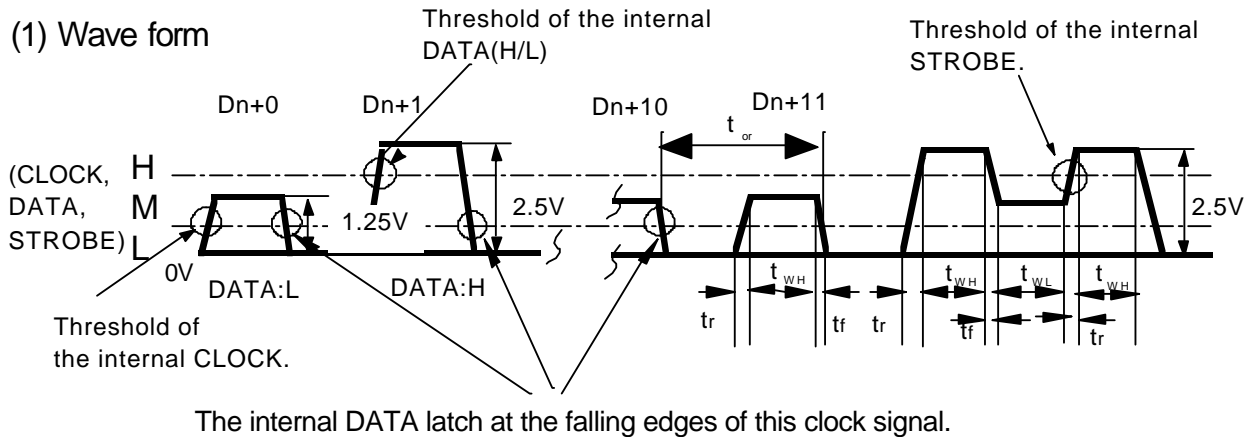

(2) Voltage control signal

Digital input signal	Condition	Limits			Unit	
		min.	typ.	max.		
L signal	L	VDD=2.5V, VSS=-2.5V	GND	—	0.4	V
M signal	M	VDD=2.5V, VSS=-2.5V	1.0	1.25 (VDD/2)	1.5	
H signal	H	VDD=2.5V, VSS=-2.5V	2.1	—	VDD	

(3) Timing control signal

Symbol	Parameter	Limits			Unit
		min	typ	max	
t_{cr}	Cycle time of digital signal	8	—	—	usec
t_{wH}	Pulse width of digital signal("H"level)	3.6	—	—	
t_{wL}	Pulse width of digital signal("L"level)	3.6	—	—	
t_r	Rise time of digital signal	—	—	0.4	
t_f	Fall time of digital signal	—	—	0.4	

(4) Control signal example(Refer to page 6 on the control data)

An example of the mode control

BYPASS/QXpander SW:QXpander
 VOL/TREBLE SHARE AMP GAIN:20dB
 INPUT :INA,
 VOLUME :0dB
 MUTE :OFF

MODE:STEREO
 BASS:18dB
 TREBLE:6dB
 RECOUT:ON(INE)

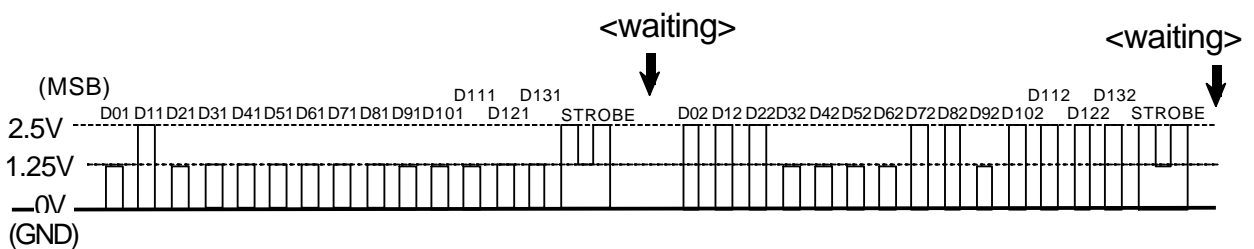

CONTROL DATA FORMAT

*It's necessary to set the all control data after power on.

(1) INPUT DATA

(MSB) ← Input order

	D01	D11	D21	D31	D41	D51	D61	D71	D81	D91	D101	D111	D121	D131
Slot1	0	Bypass/ QXpander SW	Vol/Treble share amp gain SW 0:20dB 1:18dB 2:16dB 3:14dB		INPUT 0:IN A 1:IN B 2:IN C 3:IN D		D2 to D6:(a)Master volume condition					MUTE ON/OFF 0:OFF 1:ON (INPUT ALL OFF)	CHIP/SLOT SELECT 0:select 1:no select 2:no select 3:no select	
	D02	D12	D22	D32	D42	D52	D62	D72	D82	D92	D102	D112	D122	D132
Slot2	1	1	0	1	Mode select 0:stereo 1:mono1 only 2:mono2 only 3:mono1+2		Bass(boost) 0:0dB, 1:3dB, 2:6dB, 3:9dB, 4:12dB, 5:15dB, 6:18dB, 7:21dB		Treble(boost) 0:0dB,1:3dB 2:6dB,3:9dB		IN E ON/OFF 0:OFF 1:ON	CHIP/SLOT SELECT 0:no select 1:no select 2:no select 3:select		

(a) Master volume

ATT	D61	D71	D81	D91	D101
-0.0dB	0	0	0	0	0
-2.0dB	1	0	0	0	0
-4.0dB	0	1	0	0	0
-6.0dB	1	1	0	0	0
-8.0dB	0	0	1	0	0
-10.0dB	1	0	1	0	0
-12.0dB	0	1	1	0	0
-14.0dB	1	1	1	0	0
-16.0dB	0	0	0	1	0
-18.0dB	1	0	0	1	0
-20.0dB	0	1	0	1	0
-22.0dB	1	1	0	1	0
-24.0dB	0	0	1	1	0
-26.0dB	1	0	1	1	0
-28.0dB	0	1	1	1	0
-30.0dB	1	1	1	1	0
-32.0dB	0	0	0	0	1
-34.0dB	1	0	0	0	1
-36.0dB	0	1	0	0	1
-40.0dB	1	1	0	0	1
-44.0dB	0	0	1	0	1
-48.0dB	1	0	1	0	1
-52.0dB	0	1	1	0	1
-56.0dB	1	1	1	0	1
-60.0dB	0	0	0	1	1
-64.0dB	1	0	0	1	1
-68.0dB	0	1	0	1	1
-72.0dB	1	1	0	1	1
-76.0dB	0	0	1	1	1
-80.0dB	1	0	1	1	1
-84.0dB	0	1	1	1	1
the infinitesimal	1	1	1	1	1

(b) Input select

Input select	D41	D51	D111	D112
IN A	0	0	0	0
IN B	1	0		
IN C	0	1		
IN D	1	1		
IN A to D all OFF	*	*	1	1 *1
IN A-D select	IN E on	A: 0	0	1
		B: 1		
		C: 0		
		D: 1		

*1) The input impedance is about 5k as input INE.

*2) INE can be controlled independently.

It can be used as Rec output.

(c) Mode control

Mode	D42	D52
stereo	0	0
mono1 only	1	0
mono2 only	0	1
mono1+2	1	1

(d) Treble control

Treble	D92	D102
0dB	0	0
3dB	1	0
6dB	0	1
9dB	1	1

(e) Bass control

Bass	D62	D72	D82
0dB	0	0	0
3dB	1	0	0
6dB	0	1	0
9dB	1	1	0
12dB	0	0	1
15dB	1	0	1
18dB	0	1	1
21dB	1	1	1

(f) Chip/Slot control

Chip/Slot	D12*	D13*
select(slot1)	0	0
no select	1	0
no select	0	1
select(slot1)	1	1

(g) Treble amp gain SW

Gain SW	D21	D31
20dB	0	0
18dB	1	0
16dB	0	1
14dB	1	1

(h) Bypass/
QXpander SW

Bypass/ QXpander SW	D11
Bypass	0
QXpander	1

(2) NOTICE OF CONTROL DATA

1. use **only** the control data of (1) INPUT DATA.

2. The interval of data transmission from the microcontroller is over 0.1 sec.: This is **the waiting time** for the "soft-switching" to reduce the shock noise.

(The "soft-switching" is available at the volume and QXpander.)

=

<NOTE>

(1) The "Slot1" and the "Slot2" are **independent data**. Each data need each waiting time.

(2) The some function of the volume and other function have no "Soft-Switching".

<Example 1>

When the volume is set as "infinitesimal", it's immediately attenuated (but, it needs the waiting time to reach the final attenuation).

<Example 2>

The change of tone control is immediately executed.

3. It's necessary to **set the all control data** after power-on, although the internal circuit is forced as below, when (VDD-VSS)<3.3V(TYP).

Parameter	Condition
Gain SW	18dB
Input select	ALL OFF
Master volume	infinitesimal
MUTE	ON(Input ALLOFF)
Bypass / QXpander	Bypass
Mode select	stereo
Bass	0dB
Treble	0dB
IN E	ON



ELECTRICAL CHARACTERISTICS

(VDD=2.5V, VSS=-2.5V, f=1kHz, Vi=100mV(rms), VOL=0dB, BASS=0dB, TREBLE=0dB, VOL/TREBLE SHARE AMP=18dB, SURROUND=BYPASS, RL=10K, Ta=25°C, unless otherwise noted)

Symbol	Parameter	Condition	Limits			Unit		
			min.	typ.	max.			
IDD	Circuit current of positive power supply	Quiescent	—	30	45	mA		
ISS	Circuit current of negative power supply	Quiescent	—	-30	-45	mA		
Gv1	Voltage gain (selector)	Vol/Treble share amp gain=18dB Bypass	16	18	20	dB		
Gv2	Voltage gain (tone control)	Vol/Treble share amp gain=18dB QXpander mode Vi=20mVrms	25.5	27.5	29.5	dB		
Vomax	Maximum output voltage	RL=10k, THD=1%	1.2	1.6	—	Vrms		
THD	Total harmonic distortion	BW=400 ~ 30kHz	—	0.02	0.08	%		
No1	Output noise voltage	JIS-A, Rg=5.1k, VOL=the infinitesimal BYPASS	—	6	15	uVrms		
No2		JIS-A, Rg=5.1k, VOL=the infinitesimal QXpander mode	—	11	30	uVrms		
ATTmax	Maximum attenuation	Output reference level (Vo=1Vrms), ATT=the infinitesimal, JIS-A	—	-95	-90	dB		
GB1	Bass boost	3dB	f=1kHz, Vo=80mVrms	1.5	3	4.5	dB	
GB2				6dB	4.5	6		7.5
GB3				9dB	7.5	9		10.5
GB4				12dB	10.5	12		13.5
GB5				15dB	13.5	15		16.5
GB6				18dB	16.5	18		19.5
GB7				21dB	19.5	21		22.5
GT1	Treble boost	3dB	f=1kHz, Vo=80mVrms	1.5	3	4.5	dB	
GT2				6dB	4.5	6		7.5
GT3				9dB	7.5	9		10.5

FUNCTION DESCRIPTION

(1) Equivalent circuit of the bass boost

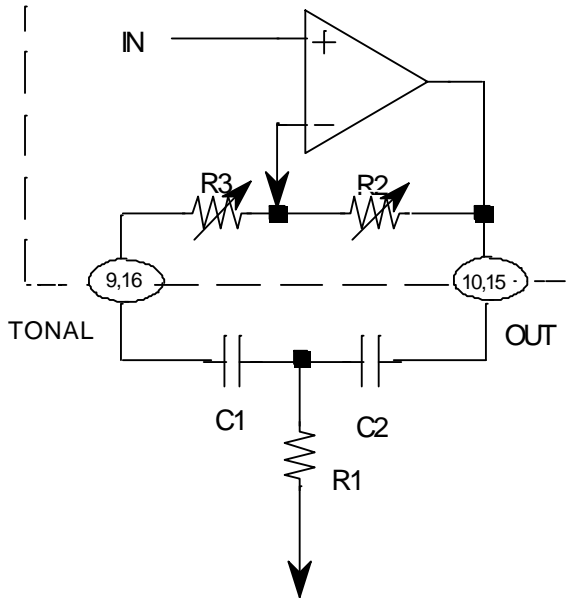

$$F_{ob} = \frac{1}{2\pi\sqrt{R1(R2+R3)C1C2}} \quad (\text{Hz})$$

$$Q = \frac{1}{C1+C2} \sqrt{\frac{C1C2R2}{R1}}$$

$$(C1=C2) \quad Gv = 20 \log \frac{\frac{R2+R3}{R1} + 2}{\frac{R3}{R1} + 2} \quad (\text{dab})$$

R2, R3 (typical)

Bass boost	3dB	6dB	9dB	12dB	15dB	18dB	21dB	
Resistor	R2	15.4	25.7	32.9	38.7	41.6	44.2	46
(k)	R3	30.6	20.3	13.1	7.3	4.4	1.8	0

(2) Equivalent circuit of the treble boost

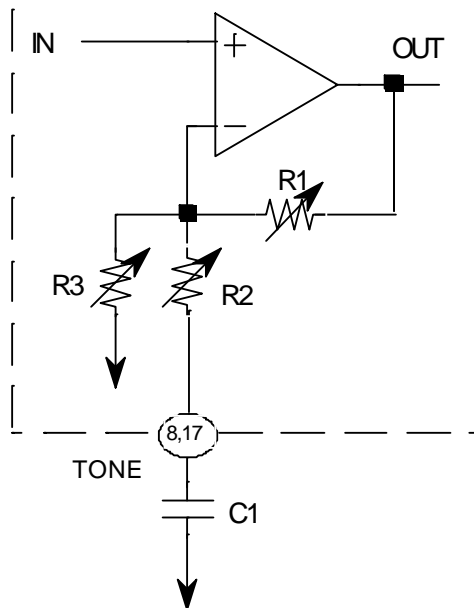

$$F_c = \frac{1}{2\pi R2 C1} \quad (\text{Hz})$$

$$Gv = 20 \log \frac{R1 + \{(R2+Zc)\}/R3}{(R2+Zc)\}/R3} \quad (\text{dab})$$

$$Zc = \frac{1}{j\omega C1} \quad (\text{ohm})$$

R2 (typical)

Treble boost	3dB	6dB	9dB
R2 (k)	5.3	2.2	1.2

R1, R3 (typical)

Gain	14dB	16dB	18dB	20dB
R1 (k)	10.88	13.65	17.21	21.60
R3 (k)	2.72	2.57	2.48	2.40

APPLICATION EXAMPLE

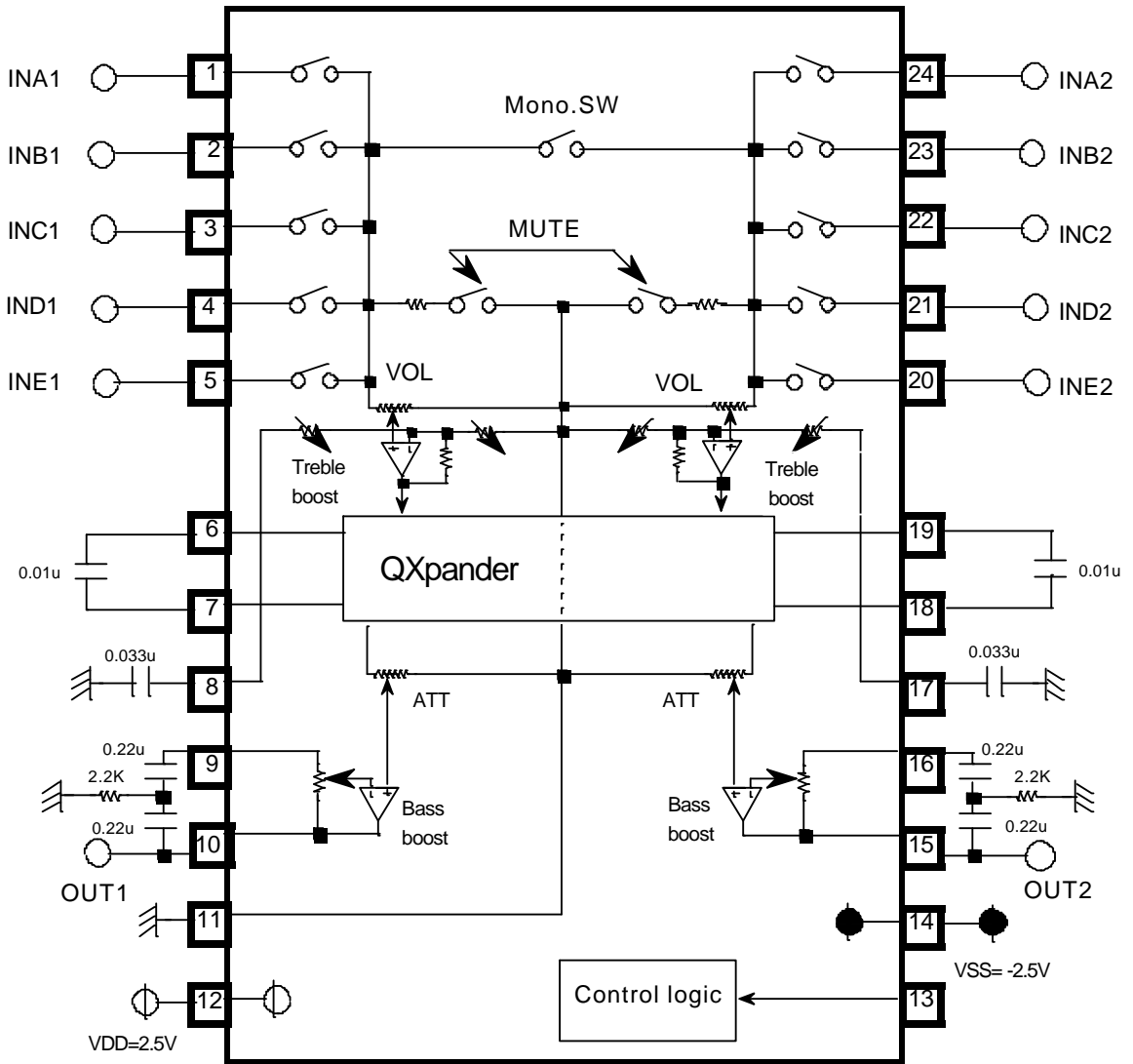

Units Resistor : ohm
Capacitor: F

OUTLINE

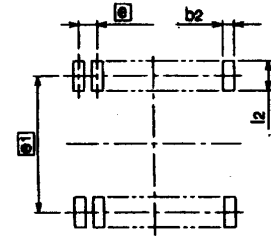
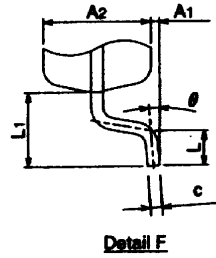
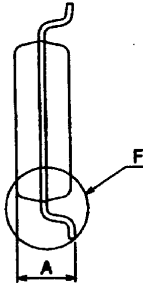
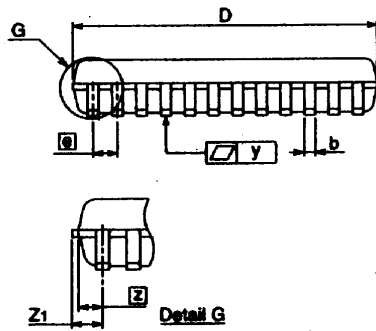
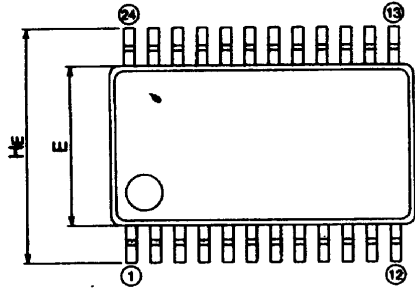

Recommended Mount Pad

Symbol	Dimension in Millimeters		
	Min	Nom	Max
A	-	-	2.1
A1	0	0.1	0.2
A2	-	1.8	-
b	0.3	0.35	0.45
c	0.18	0.2	0.25
D	10.0	10.1	10.2
E	5.2	5.3	5.4
a1	-	0.8	-
HE	7.5	7.8	8.1
L	0.4	0.6	0.8
L1	-	1.25	-
l2	-	0.65	-
Z1	-	-	0.8
y	-	-	0.1
θ	0°	-	8°
b2	-	0.5	-
a1	-	7.62	-
l2	1.27	-	-